

## NTTA01BJE6-C

Ciena® NTTA01BJE6 Compatible 100GBase-LR4 CFP Transceiver (SMF, 1310nm, 10km, LC)

### Features:

- CFP MSA 1.4 Compliance
- Duplex LC Connector
- Commercial Temperature 0 to 70 Celsius
- Single-mode Fiber
- Hot Pluggable
- Excellent ESD Protection
- Metal with Lower EMI
- RoHS Compliant and Lead Free



### Applications:

- 100GBase Ethernet
- OTU4 Operation
- Access and Enterprise

### Product Description

This Ciena® NTTA01BJE6 compatible CFP transceiver provides 100GBase-LR4 throughput up to 10km over single-mode fiber (SMF) using a wavelength of 1310nm via an LC connector. It is guaranteed to be 100% compatible with the equivalent Ciena® transceiver. This easy to install, hot swappable transceiver has been programmed, uniquely serialized and data-traffic and application tested to ensure that it will initialize and perform identically. Digital optical monitoring (DOM) support is also present to allow access to real-time operating parameters. This transceiver is Trade Agreements Act (TAA) compliant. We stand behind the quality of our products and proudly offer a limited lifetime warranty.

ProLabs' transceivers are RoHS compliant and lead-free.

TAA refers to the Trade Agreements Act (19 U.S.C. & 2501-2581), which is intended to foster fair and open international trade. TAA requires that the U.S. Government may acquire only "U.S. – made or designated country end products."



## Absolute Maximum Ratings

Parameter	Symbol	Min.	Max.	Unit
Storage Temperature	TS	-40	+85	°C
Power Supply Voltage	VCC	-0.5	3.6	V
Operating Case Temperature Range	Tc	-10	+75	°C
Relative Humidity	Rh	5	85	%

## Electrical Characteristics

Parameter	Symbol	Min.	Typ.	Max.	Unit	
Power Supply Voltage	VCC	3.2	3.3	3.4	V	
Power Supply Current	Icc		4000		mA	
<b>Transmitter</b>						
Differential data input swing	Vin			1050	mVp-p	
Input differential impedance	Zin	80	100	120	Ω	
<b>Receiver</b>						
Differential data output swing	Vout, pp	360		770	mVp-p	
Output differential impedance	Zo	80	100	120	Ω	
Output Rise/Fall Time	tr/tf	24			ps	20%~80%

## 1.2V MDIO Interface Specifications

Parameter	Symbol	Min.	Typ.	Max	Unit	Notes
Input Voltage	VIH	0.84		1.5	V	
	VIL	-0.3		0.36	V	
Input Leak current	IIN	-100		100	uA	
Output Voltage	VOH	1.0		1.5	V	
	VOL	-0.3		0.2	V	
Input Capacitance	CI			10	pF	
Input MDC Clock	fMDC	0.1		4	MHz	
MDC Clock Period	TMDC	250		10000	ns	
MDIO Hold Time	Thold	10			ns	
MDIO Setup Time	Tsetup	10			ns	
GLB_ALM	Tglb_alm_ass			150	ms	
	Tglb_alm_dea			150	ms	

## OTU4 411-9D1F Operation Optical Characteristics

Parameter	Symbol	Min.	Typical	Max.	Unit	Notes
<b>Transmitter</b>						
Signaling Speed per Lane	BRAVE		27.95		Gbps	
Lane_0 Center Wavelength	$\lambda_{C0}$	1294.53	1295.56	1296.59	nm	
Lane_1 Center Wavelength	$\lambda_{C1}$	1299.02	1300.05	1301.09	nm	
Lane_2 Center Wavelength	$\lambda_{C2}$	1303.54	1304.58	1305.63	nm	
Lane_3 Center Wavelength	$\lambda_{C3}$	1308.09	1309.14	1310.19	nm	
Total Average Output Power	PO1	-		8.9	dBm	1, 2
Average Launch Power per Lane	P <sub>each1</sub>	-2.5		2.9	dBm	2
Side Mode Suppression Ratio	SMSR	30			dB	
Optical Return Loss Tolerance				20	dB	
Extinction Ratio	ER <sub>1</sub>	7			dB	2
Transmitter eye mask definition {X1, X2, X3, Y1, Y2, Y3}		G.959.1 Compliant				2
TX Disable Assert Time	t <sub>off</sub>			100	us	
<b>Receiver</b>						
Signaling Speed per Lane	BRAVE		27.95		Gbps	
Lane_0 Center Wavelength	$\lambda_{C0}$	1294.53	1295.56	1296.59	nm	
Lane_1 Center Wavelength	$\lambda_{C1}$	1299.02	1300.05	1301.09	nm	
Lane_2 Center Wavelength	$\lambda_{C2}$	1303.54	1304.58	1305.63	nm	
Lane_3 Center Wavelength	$\lambda_{C3}$	1308.09	1309.14	1310.19	nm	
Average Receive Power per Lane	R <sub>pow1</sub>	-8.8		4	dBm	5
Equivalent Sensitivity per Lane	P <sub>min1</sub>			-10.3	dBm	7
Receiver Overload per Lane	P <sub>max</sub>	5.5			dBm	
Optical Return Loss	ORL			-26	dB	
LOS Assert	LOSA	-21			dBm	
LOS De-Assert	LOSD			-11	dBm	
LOS Hysteresis		0.5			dB	

## 100GBASE-LR4 Operation Optical Characteristics

Parameter	Symbol	Min.	Typical	Max.	Unit	Notes
<b>Transmitter</b>						
Signaling Speed per Lane	BRAVE		25.78		Gbps	
Lane_0 Center Wavelength	$\lambda_{C0}$	1294.53	1295.56	1296.59	nm	
Lane_1 Center Wavelength	$\lambda_{C1}$	1299.02	1300.05	1301.09	nm	
Lane_2 Center Wavelength	$\lambda_{C2}$	1303.54	1304.58	1305.63	nm	
Lane_3 Center Wavelength	$\lambda_{C3}$	1308.09	1309.14	1310.19	nm	
Total Average Output Power	PO2	-		10.5	dBm	1, 4
Average Launch Power per Lane	P <sub>each2</sub>	-4.3		4.5	dBm	4
Side Mode Suppression Ratio	SMSR	30			dB	
Optical Return Loss Tolerance				20	dB	
Extinction Ratio	ER <sub>2</sub>	7			dB	4
Transmitter eye mask definition {X1, X2, X3, Y1, Y2, Y3}		IEEE802.3ba-2010 Compliant				4
TX Disable Assert Time	t <sub>off</sub>			100	us	
<b>Receiver</b>						
Signaling Speed per Lane	BRAVE		25.78		Gbps	
Lane_0 Center Wavelength	$\lambda_{C0}$	1294.53	1295.56	1296.59	nm	
Lane_1 Center Wavelength	$\lambda_{C1}$	1299.02	1300.05	1301.09	nm	
Lane_2 Center Wavelength	$\lambda_{C2}$	1303.54	1304.58	1305.63	nm	
Lane_3 Center Wavelength	$\lambda_{C3}$	1308.09	1309.14	1310.19	nm	
Average Receive Power per Lane	R <sub>pow2</sub>	-10.6		4.5	dBm	6
Receive Sensitivity (OMA) per Lane	P <sub>min2</sub>			-8.6	dBm	8
Stressed Sensitivity (OMA) per lane	SRS			-6.8	dBm	
Receiver Overload per Lane	P <sub>max</sub>	5.5			dBm	
Optical Return Loss	ORL			-26	dB	
LOS Assert	LOSA	-21			dBm	
LOS De-Assert	LOSD			-11	dBm	
LOS Hysteresis		0.5			dB	

### Notes:

1. Output is coupled into a 9/125 $\mu$ m single-mode fiber.
2. Filtered, measured with a PRBS 2<sup>31</sup>-1 test pattern @27.95Gbps
3. High speed I/O, internally AC coupled.
4. Filtered, measured with a PRBS 2<sup>31</sup>-1 test pattern @25.78Gbps
5. CFP transceiver works in OTU4 4I1-9D1F mode.
6. CFP transceiver works in 100GBASE-LR4 mode.

7. Minimum average optical power measured at BER less than 1E-12, with a  $2^{31}-1$  PRBS@27.95Gbps.
8. Minimum OMA optical power measured at BER less than 1E-12, with a  $2^{31}-1$  PRBS@25.78Gbps.

### Functional Description of Transceiver

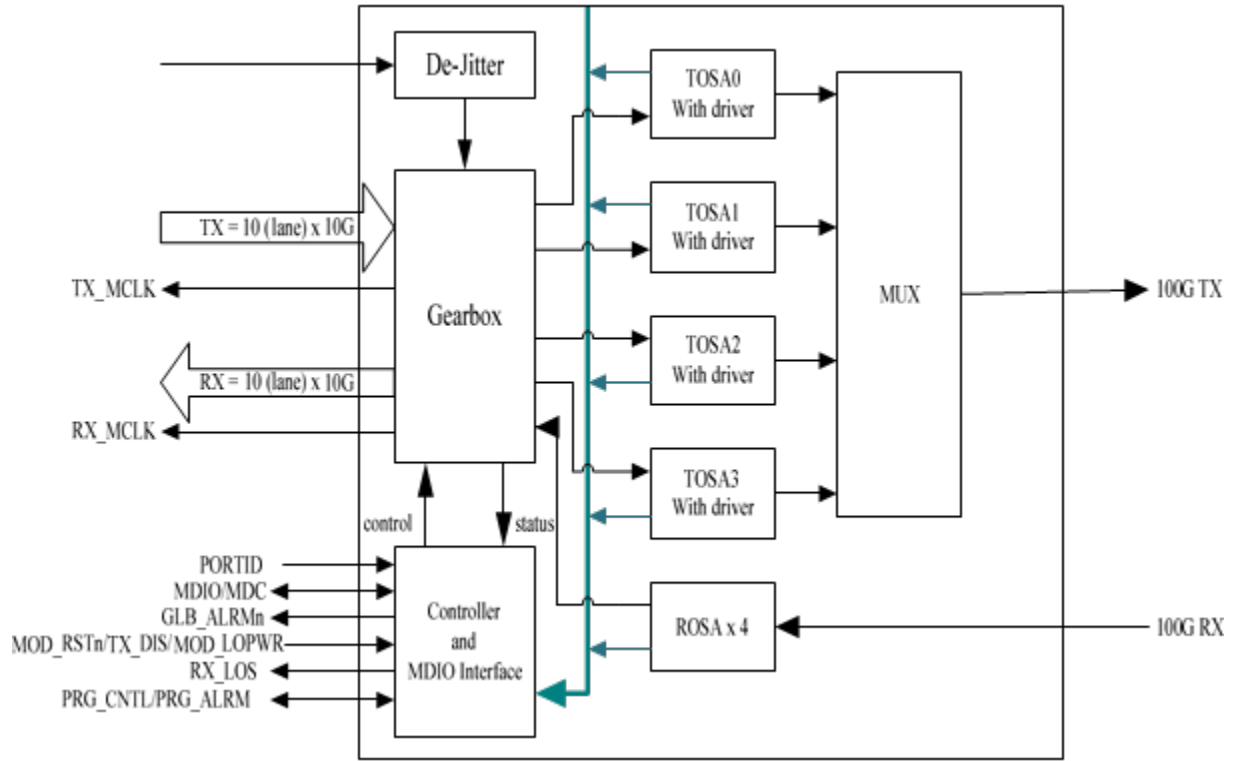

### Electrical Pad Layout



## Pin Descriptions

### Part A: Bottom Row Pin Function Definition

Pin	Name	Function	Notes
1	3.3V_GND	Ground	3.3V Module Supply Ground, Internally connected to Signal Ground
2	3.3V_GND	Ground	3.3V Module Supply Ground, Internally connected to Signal Ground
3	3.3V_GND	Ground	3.3V Module Supply Ground, Internally connected to Signal Ground
4	3.3V_GND	Ground	3.3V Module Supply Ground, Internally connected to Signal Ground
5	3.3V_GND	Ground	3.3V Module Supply Ground, Internally connected to Signal Ground
6	3.3V	3.3V Module Supply Voltage	3.3V ± 2.5%
7	3.3V	3.3V Module Supply Voltage	3.3V ± 2.5%
8	3.3V	3.3V Module Supply Voltage	3.3V ± 2.5%
9	3.3V	3.3V Module Supply Voltage	3.3V ± 2.5%
10	3.3V	3.3V Module Supply Voltage	3.3V ± 2.5%
11	3.3V	3.3V Module Supply Voltage	3.3V ± 2.5%
12	3.3V	3.3V Module Supply Voltage	3.3V ± 2.5%
13	3.3V	3.3V Module Supply Voltage	3.3V ± 2.5%
14	3.3V	3.3V Module Supply Voltage	3.3V ± 2.5%
15	3.3V	3.3V Module Supply Voltage	3.3V ± 2.5%
16	3.3V_GND	Ground	3.3V Module Supply Ground, Internally connected to Signal Ground
17	3.3V_GND	Ground	3.3V Module Supply Ground, Internally connected to Signal Ground
18	3.3V_GND	Ground	3.3V Module Supply Ground, Internally connected to Signal Ground
19	3.3V_GND	Ground	3.3V Module Supply Ground, Internally connected to Signal Ground
20	3.3V_GND	Ground	3.3V Module Supply Ground, Internally connected to Signal Ground
21	VND_IO_A	I/O	Module Vendor I/O, NC
22	VND_IO_B	I/O	Module Vendor I/O, NC
23	GND	Ground	Signal Ground
24	(TX_MCLKn)	Tx Monitor Clock O	Tx Monitor Clock Output
25	(TX_MCLKp)	Tx Monitor Clock O	Tx Monitor Clock Output
26	GND	Ground	Signal Ground
27	VND_IO_C	I/O	Module Vendor I/O, must not connect at host board
28	VND_IO_D	I/O	Module Vendor I/O, must not connect at host board
29	VND_IO_E	I/O	Module Vendor I/O, must not connect at host board
30	PRG_CNTL1	I	LVCOMS
31	PRG_CNTL2	I	LVCOMS
32	PRG_CNTL3	I	LVCOMS
33	PRG_ALARM1	O	LVCOMS
34	PRG_ALARM2	O	LVCOMS
35	PRG_ALARM3	O	LVCOMS
36	TX_DIS	Transmitter Disable I	"1" or NC = transmitter disabled, "0" = transmitter enabled
37	MOD_LOPW R	Module Low Power Mode I	"1" or NC: module in low power (safe) mode, "0": power-on enabled
38	MOD_ABS	Module Absent O	"1" or NC: module absent, "0": module present
39	MOD_RSTn	Module Reset I	"0" resets the module, "1" or NC = module enabled
40	RX_LOS	Loss of Signal O	"1": low optical signal, "0": normal condition

41	GLB_ALRMn	Global Alarm O	"0": alarm condition in any MDIO Alarm register, "1": no alarm condition
42	PRTADR4	1.2V CMOS I	MDIO Physical Port address bit4
43	PRTADR3	1.2V CMOS I	MDIO Physical Port address bit3
44	PRTADR2	1.2V CMOS I	MDIO Physical Port address bit2
45	PRTADR1	1.2V CMOS I	MDIO Physical Port address bit1
46	PRTADR0	1.2V CMOS I	MDIO Physical Port address bit0
47	MDIO	1.2V CMOS I/O	Management Data I/O bi-directional data
48	MDC	1.2V CMOS I	Management Data Clock
49	GND	Ground	Signal Ground
50	VND_IO_F	I/O	Module Vendor I/O, Not Connected Internally
51	VND_IO_G	I/O	Module Vendor I/O, Not Connected Internally
52	GND	Ground	Signal Ground
53	VND_IO_H	I/O	Module Vendor I/O, Not Connected Internally
54	VND_IO_J	I/O	Module Vendor I/O, Not Connected Internally
55	3.3V_GND	Ground	3.3V Module Supply Ground, Internally connected to Signal Ground
56	3.3V_GND	Ground	3.3V Module Supply Ground, Internally connected to Signal Ground
57	3.3V_GND	Ground	3.3V Module Supply Ground, Internally connected to Signal Ground
58	3.3V_GND	Ground	3.3V Module Supply Ground, Internally connected to Signal Ground
59	3.3V_GND	Ground	3.3V Module Supply Ground, Internally connected to Signal Ground
60	3.3V	3.3V Module Supply Voltage	3.3V ± 2.5%
61	3.3V	3.3V Module Supply Voltage	3.3V ± 2.5%
62	3.3V	3.3V Module Supply Voltage	3.3V ± 2.5%
63	3.3V	3.3V Module Supply Voltage	3.3V ± 2.5%
64	3.3V	3.3V Module Supply Voltage	3.3V ± 2.5%
65	3.3V	3.3V Module Supply Voltage	3.3V ± 2.5%
66	3.3V	3.3V Module Supply Voltage	3.3V ± 2.5%
67	3.3V	3.3V Module Supply Voltage	3.3V ± 2.5%
68	3.3V	3.3V Module Supply Voltage	3.3V ± 2.5%
69	3.3V	3.3V Module Supply Voltage	3.3V ± 2.5%
70	3.3V_GND	Ground	3.3V Module Supply Ground, Internally connected to Signal Ground
71	3.3V_GND	Ground	3.3V Module Supply Ground, Internally connected to Signal Ground
72	3.3V_GND	Ground	3.3V Module Supply Ground, Internally connected to Signal Ground
73	3.3V_GND	Ground	3.3V Module Supply Ground, Internally connected to Signal Ground
74	3.3V_GND	Ground	3.3V Module Supply Ground, Internally connected to Signal Ground

#### Part B: Top Row Pin Function Definition

Pin	Name	Function	Notes
148	GND	Ground	Signal Ground
147	REFCLKn	Reference Clock I	Reference Clock Input
146	REFCLKp	Ground	3.3V Module Supply Ground, Internally connected to Signal Ground
145	GND	Ground	Signal Ground
144	N.C.		Not Connected Internally
143	N.C.		Not Connected Internally
142	GND	Ground	Signal Ground
141	TX9n	Lane 9 Tx Input I	

140	TX9p	Lane 9 Tx Input I	
139	GND	Ground	Signal Ground
138	TX8n	Lane 8 Tx Input I	3.3V ± 2.5%
137	TX8p	Lane 8 Tx Input I	3.3V ± 2.5%
136	GND	Ground	Signal Ground
135	TX7n	Lane 7 Tx Input I	3.3V ± 2.5%
134	TX7p	Lane 7 Tx Input I	3.3V ± 2.5%
133	GND	Ground	Signal Ground
132	TX6n	Lane 6 Tx Input I	
131	TX6p	Lane 6 Tx Input I	
130	GND	Ground	Signal Ground
129	TX5n	Lane 5 Tx Input I	
128	TX5p	Lane 5 Tx Input I	
127	GND	Ground	Signal Ground
126	TX4n	Lane 4 Tx Input I	
125	TX4p	Lane 4 Tx Input I	
124	GND	Ground	Signal Ground
123	TX3n	Lane 3 Tx Input I	
122	TX3p	Lane 3 Tx Input I	
121	GND	Ground	Signal Ground
120	TX2n	Lane 2 Tx Input I	
119	TX2p	Lane 2 Tx Input I	
118	GND	Ground	Signal Ground
117	TX1n	Lane 1 Tx Input I	
116	TX1p	Lane 1 Tx Input I	
115	GND	Ground	Signal Ground
114	TX0n	Lane 0 Tx Input I	
113	TX0p	Lane 0 Tx Input I	
112	GND	Ground	Signal Ground
111	GND	Ground	Signal Ground
110	N.C.		Not Connected Internally
109	N.C.		Not Connected Internally
108	GND	Ground	Signal Ground
107	RX9n	Lane 9 Rx Output O	
106	RX9p	Lane 9 Rx Output O	
105	GND	Ground	Signal Ground
104	RX8n	Lane 8 Rx Output O	
103	RX8p	Lane 8 Rx Output O	
102	GND	Ground	Signal Ground
101	RX7n	Lane 7 Rx Output O	
100	RX7p	Lane 7 Rx Output O	
99	GND	Ground	Signal Ground
98	RX6n	Lane 6 Rx Output O	
97	RX6p	Lane 6 Rx Output O	
96	GND	Ground	Signal Ground
95	RX5n	Lane 5 Rx Output O	
94	RX5p	Lane 5 Rx Output O	



93	GND	Ground	Signal Ground
92	RX4n	Lane 4 Rx Output O	
91	RX4p	Lane 4 Rx Output O	
90	GND	Ground	Signal Ground
89	RX3n	Lane 3 Rx Output O	
88	RX3p	Lane 3 Rx Output O	
87	GND	Ground	Signal Ground
86	RX2n	Lane 2 Rx Output O	
85	RX2p	Lane 2 Rx Output O	
84	GND	Ground	Signal Ground
83	RX1n	Lane 1 Rx Output O	
82	RX1p	Lane 1 Rx Output O	
81	GND	Ground	Signal Ground
80	RX0n	Lane 0 Rx Output O	
79	RX0p	Lane 0 Rx Output O	
78	GND	Ground	Signal Ground
77	RX_MCLKn	Rx Monitor Clock O	Rx Monitor Clock Output
76	RX_MCLKp	Rx Monitor Clock O	Rx Monitor Clock Output
75	GND	Ground	Signal Ground

### Mechanical Specifications

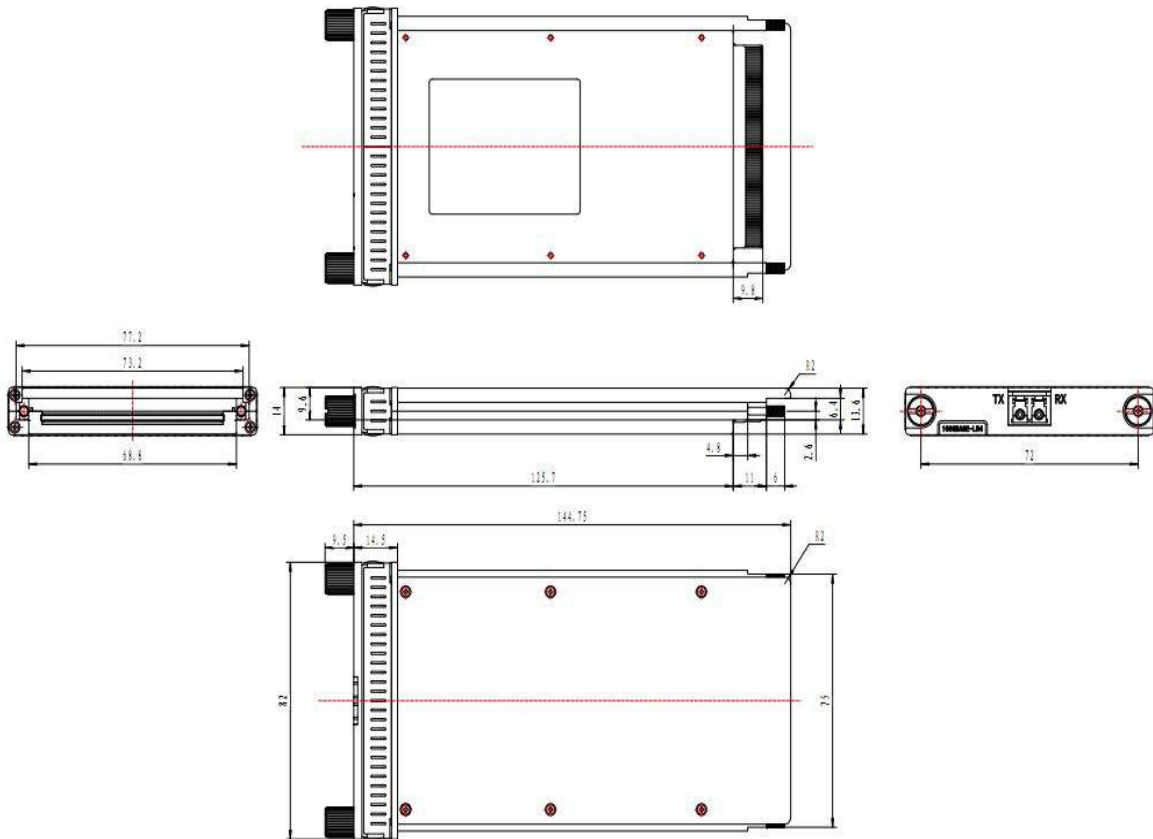

Laser Emission

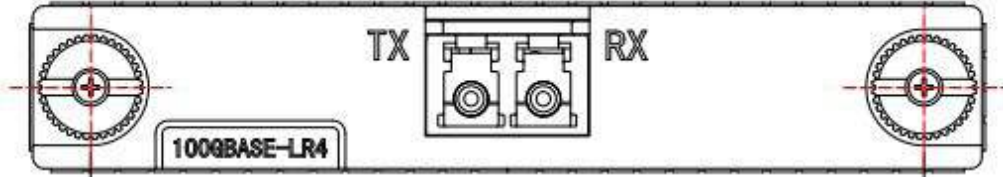

## About ProLabs

Our experience comes as standard; for over 15 years ProLabs has delivered optical connectivity solutions that give our customers freedom and choice through our ability to provide seamless interoperability. At the heart of our company is the ability to provide state-of-the-art optical transport and connectivity solutions that are compatible with over 90 optical switching and transport platforms.

## Complete Portfolio of Network Solutions

ProLabs is focused on innovations in optical transport and connectivity. The combination of our knowledge of optics and networking equipment enables ProLabs to be your single source for optical transport and connectivity solutions from 100Mb to 400G while providing innovative solutions that increase network efficiency. We provide the optical connectivity expertise that is compatible with and enhances your switching and transport equipment.

## Trusted Partner

Customer service is our number one value. ProLabs has invested in people, labs and manufacturing capacity to ensure that you get immediate answers to your questions and compatible product when needed. With Engineering and Manufacturing offices in the U.K. and U.S. augmented by field offices throughout the U.S., U.K. and Asia, ProLabs is able to be our customers best advocate 24 hours a day.



## Contact Information

ProLabs US

Email: [sales@prolabs.com](mailto:sales@prolabs.com)

Telephone: 952-852-0252

ProLabs UK

Email: [salessupport@prolabs.com](mailto:salessupport@prolabs.com)

Telephone: +44 1285 719 600