

Quad Channel Monolithic Power Stage

DESCRIPTION

The SiP2204 is a quad channel, fully-integrated monolithic power stage optimized for multi-phase synchronous buck applications. The part has very fast propagation to enable switching frequencies of up to 10 MHz/channel and offers a high power density design for use in applications such as envelope tracking power supplies for RF power amplifiers used in next generation 4G base stations.

Packaged in QFN32 5 x 5, SiP2204 supports input voltages up to 24 V and delivers 500 mA continuous current for each channel.

The SiP2204 incorporates four independent MOSFET gate driver ICs that work with both 3.3 V and 5 V PWM inputs.

FEATURES

- QFN32 5 x 5 package
- Power stage input up to 24 V
- 500 mA per channel continuous current
- 2 A per channel peak current capability
- High frequency operation beyond 5 MHz
- 3.3 V and 5 V PWM logic
- Low PWM propagation delay (typical 13 ns)
- Enable feature to put the output at high impedance when disabled
- Junction temperature: -40 °C to +125 °C

APPLICATIONS

- Envelope tracking (ET) supplies for RF power amplifiers (LDMOS, GaAs FET, GaAs HBT or GaN based)
- Synchronous buck converters

TYPICAL APPLICATION CIRCUIT

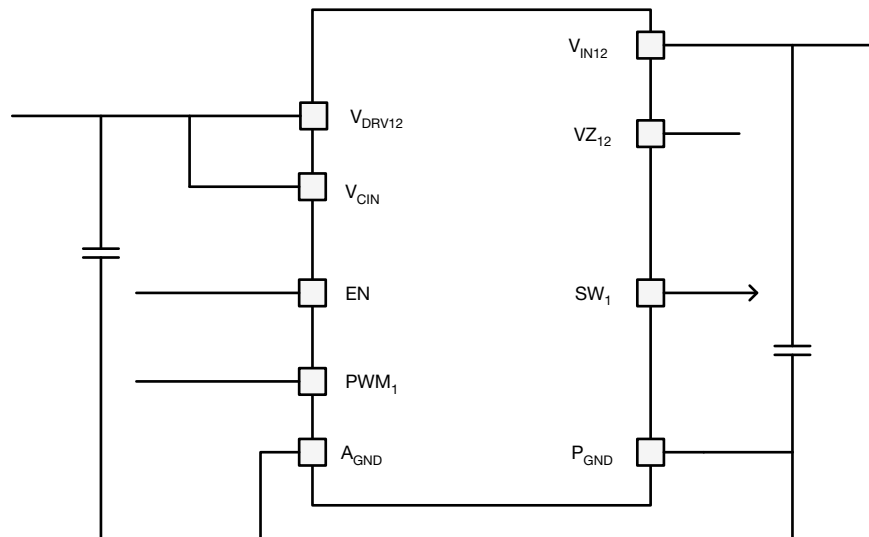
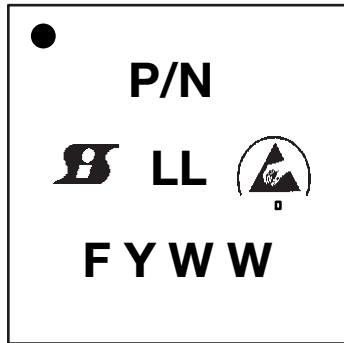



Fig. 1 - Typical Application Circuit for SiP2204
(channel 1 shown)

PART MARKING

- = pin 1 indicator
- P/N = part number code
- B** = Siliconix logo
-  = ESD symbol
- F = assembly factory code
- Y = year code
- WW = week code
- LL = lot code

| ABSOLUTE MAXIMUM RATINGS | | | |
|--|-----------------------------------|--|------|
| ELECTRICAL PARAMETER | CONDITIONS | LIMIT | UNIT |
| Input voltage | V_{INX} | -0.3 to +26 | V |
| Control logic supply voltage | V_{CIN} | -0.3 to +6 | |
| Low-side driver supply voltage | V_{DRVX} | -0.3 to +6 | |
| Switch node (DC voltage) | SW_X | -0.3 to +26 | |
| Switch node (AC voltage) ⁽¹⁾ | | 29 | |
| High-side regulator output monitor voltage | V_{ZX} | $(V_{INX} - 6)$ to V_{INX} and $V_{ZX} > -0.3$ | |
| All logic inputs and outputs (PWM _X and EN) | | -0.3 to $V_{CIN} + 0.3$ | |
| Max. operating junction temperature | T_J | 150 | °C |
| Ambient temperature | T_A | -40 to +125 | |
| Storage temperature | T_{stg} | -65 to +150 | |
| Electrostatic discharge protection | Human body model, JESD22-A114 | 3000 | V |
| | Charged device model, JESD22-C101 | 1000 | |

Notes

- Stresses beyond those listed under “Absolute Maximum Ratings” may cause permanent damage to the device. These are stress ratings only, and functional operation of the device at these or any other conditions beyond those indicated in the operational sections of the specifications is not implied. Exposure to absolute maximum rating conditions for extended periods may affect device reliability
- ⁽¹⁾ The specification values indicated “AC” is SW_X to P_{GND} , 29 V (< 50 ns), max.

| RECOMMENDED OPERATING RANGE | | | | |
|---|---------|---------|---------|------|
| ELECTRICAL PARAMETER | MINIMUM | TYPICAL | MAXIMUM | UNIT |
| Input voltage (V_{INX}) | 10 | - | 24 | V |
| Low-side driver supply voltage (V_{DRVX}) | 4.5 | 5 | 5.5 | |
| Control logic supply voltage (V_{CIN}) | 4.5 | 5 | 5.5 | |
| Thermal resistance from junction to PCB | - | 25 | - | °C/W |
| Thermal resistance from junction to case | - | 1 | - | |

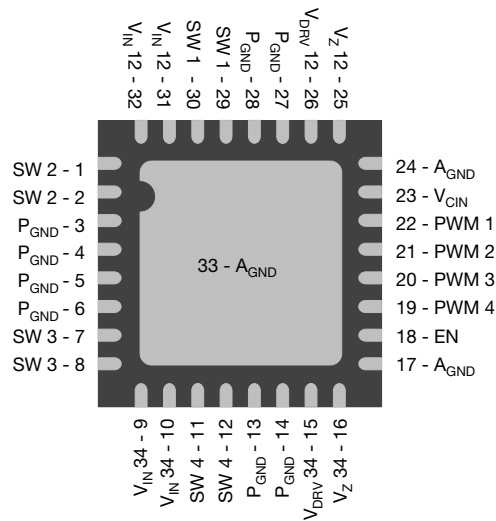
PIN CONFIGURATION

Fig. 2 - Pin Configuration for SiP2204

| PIN CONFIGURATION | | |
|---------------------------|---------------------|---|
| PIN NUMBER | PIN NAME | PIN DESCRIPTION |
| 1, 2 | SW 2 | Channel 2 driver output |
| 3 to 6, 13, 14, 27, 28 | P _{GND} | Low-side driver power return for all channels |
| 7, 8 | SW 3 | Channel 3 driver output |
| 9, 10 | V _{IN 34} | Power stage input voltage and high-side driver power supply for channel 3 and 4 |
| 11, 12 | SW 4 | Channel 4 driver output |
| 15 | V _{DRV 34} | Low-side driver power supply for channel 3 and 4 |
| 16 | V _{Z 34} | High-side regulator output monitor for channel 3 and 4 |
| 18 | EN | Global enable pin. Active high |
| 19 | PWM 4 | Channel 4 PWM input (In phase with SW) |
| 20 | PWM 3 | Channel 3 PWM input (In phase with SW) |
| 21 | PWM 2 | Channel 2 PWM input (In phase with SW) |
| 22 | PWM 1 | Channel 1 PWM input (In phase with SW) |
| 23 | V _{CIN} | Supply voltage for internal logic circuitry |
| 17, 24, 33 | A _{GND} | Analog ground |
| 25 | V _{Z 12} | High-side regulator output monitor for channel 1 and 2 |
| 26 | V _{DRV 12} | Low-side driver power supply for channel 1 and 2 |
| 29, 30 | SW 1 | Channel 1 driver output |
| 31, 32 | V _{IN 12} | Power stage input voltage and high-side driver power supply for channel 1 and 2 |



| ELECTRICAL SPECIFICATIONS | | | | | | |
|---|-----------------------|---|---|------|------|------|
| PARAMETER | SYMBOL | TEST CONDITION UNLESS OTHERWISE SPECIFIED $V_{DRVX} = V_{CIN} = EN = 5\text{ V}$, $V_{INX} = 15\text{ V}$, $V_{INX} - V_{ZX} = 5\text{ V}$, no load, PWM rise and fall time = 2 ns $T_A = 25\text{ }^\circ\text{C}$ for typical value | JUNCTION TEMPERATURE -40 °C to +125 °C unless otherwise specified | | | UNIT |
| | | | MIN. | TYP. | MAX. | |
| POWER SUPPLY | | | | | | |
| Power stage input and high-side driver supply current | I_{VIN} | EN = 0 V, PWM _X = 0 V | - | - | 1 | μA |
| | | PWM _X = 0 V | - | 90 | 130 | |
| | | PWM _X = 3.3 V (80K pull-up on high-side gate) | - | 230 | 330 | |
| | | $f_{sw} = 4\text{ MHz}$, D = 10 %, one channel | - | 14 | 27.5 | mA |
| Control logic and low-side driver supply current | $I_{VCIN} + I_{VDRV}$ | EN = 0 V, no switching, PWM = 0 | - | - | 1 | μA |
| | | PWM _X = 0 V (80K pull-down on low-side gate) | - | 370 | 530 | |
| | | PWM _X = 3.3 V | - | 90 | 130 | |
| | | $f_{sw} = 4\text{ MHz}$, D = 10 %, one channel | - | 5 | 8 | mA |
| PWMx/EN LOGIC (ALSO SEE TIMING DIAGRAM BELOW FOR ILLUSTRATION) | | | | | | |
| PWMx/EN rising threshold | V_{TH_R} | | 2.4 | - | - | V |
| PWMx/EN falling threshold | V_{TH_F} | | - | - | 0.8 | |
| PWM _X supply current | I_{PWM} | PWM _X = 5 V | - | - | 1 | μA |
| EN supply current | I_{EN} | $R_{EN} = 1\text{ M}\Omega$ to A_{GND} | - | - | 8 | |
| PWM on time ⁽¹⁾ | t_{PWM_ON} | | 12 | - | - | ns |
| PWM rising propagation delay | $t_{PD_R_PWM}$ | From PWM rises to 1.7 V to SW rises to 1.5 V; 25 °C | 8 | 15 | 22 | |
| | | From PWM rises to 1.7 V to SW rises to 1.5 V | - | - | 25 | |
| PWM falling propagation delay | $t_{PD_F_PWM}$ | From PWM falls to 1.7 V to SW falls to 1.5 V; 25 °C | 7 | 18 | 26 | |
| | | From PWM falls to 1.7 V to SW falls to 1.5 V | - | - | 30 | |
| PWM propagation delay matching ⁽²⁾ | $t_{PD_M_PWM}$ | From PWM rises to 1.7 V to SW rises to 1.5 V; 25 °C | - | 0.4 | 0.75 | |
| | | From PWM rises to 1.7 V to SW rises to 1.5 V | - | - | 1 | |
| EN propagation delay | t_{PD_EN} | From EN rise to V_{CIN} to SW start switching | - | 5 | - | μs |
| OUTPUT DRIVER | | | | | | |
| Low-side on resistance | $R_{DS(on)_N}$ | $I_{sw} = 0.1\text{ A}$ | - | 0.35 | 0.56 | Ω |
| High-side on resistance | $R_{DS(on)_P}$ | $I_{sw} = 0.1\text{ A}$, $V_{IN} - V_Z = 5\text{ V}$ | - | 0.55 | 0.92 | |

Notes

- (1) Guaranteed by design
- (2) Difference between the maximum and minimum PWM propagation delay among 4 channels

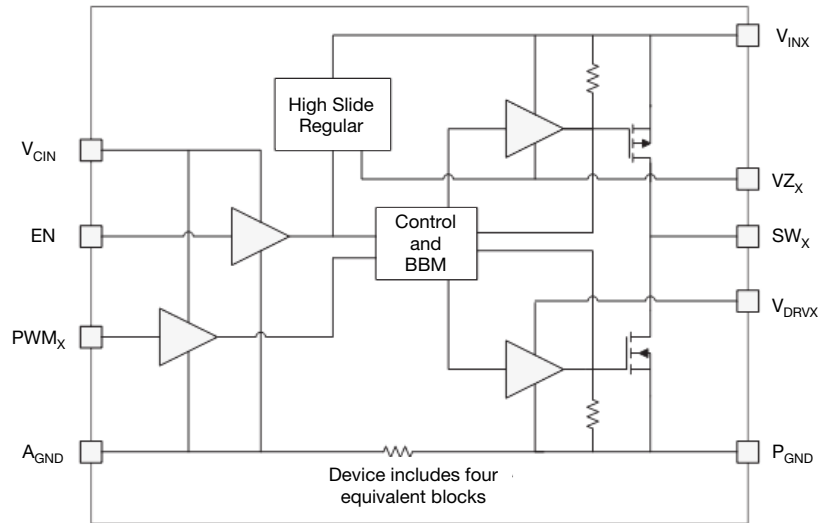
FUNCTIONAL BLOCK DIAGRAM

Fig. 3 - Functional Block Diagram for SiP2204

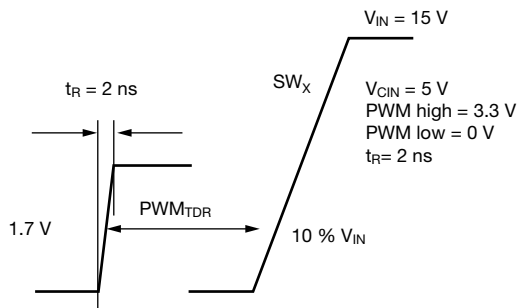
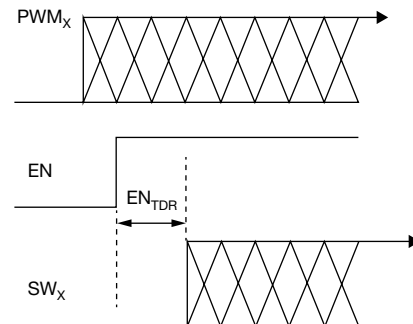
| ORDERING INFORMATION | | |
|----------------------|-----------------|--------------------------|
| PART NUMBER | PACKAGE | MARKING (LINE 2: P/N) |
| SiP2204EMP-T1-GE4 | QFN32 5 x 5 | SiP2204 |
| SiP2204DB | Reference board | |

TIMING WAVEFORMS

Fig. 4 - Timing Waveform for SiP2204

Fig. 5 - Timing Waveform for SiP2204
DETAILED OPERATIONAL DESCRIPTION
PWM Input

The PWM input receives the PWM control signal from the VR controller IC. The PWM input is designed to be compatible with standard controllers using two state logic (H and L) on the PWM output. For two state logic, the PWM input operates as follows. When PWM is driven above $V_{TH_PWM_R}$ the low-side is turned off and the high-side is turned on. When PWM input is driven below $V_{TH_PWM_F}$ the high-side turns off and the low-side turns on. The SiP2204 incorporates PWM voltage thresholds that is compatible with 3.3 V and 5 V logic.

Enable (EN)

In the low state, the EN pin shuts down the device. In this state, standby current is minimized. If EN is left unconnected, an internal pull-down resistor will pull the pin to A_{GND} and shuts down the device. The EN pin is a global enable for all four channels when driven above $V_{TH_EN_R}$.

High-Side Regulator Output Monitor (V_Z)

$V_Z 12$ and $V_Z 34$ are the output monitors for the high-side regulators. V_{ZX} is regulated to 5 V below V_{IN} (typical).

Voltage Input (V_{IN})

The power input to the drain of the high-side power MOSFET and the high-side driver supply. This pin is connected to the high power intermediate BUS rail. An 80 k Ω resistor is connected between the high-side gate and V_{IN} .

Switch Node (SW_X)

The switch node, SW, is the circuit power stage output. This is the output applied to the power inductor and output filter to deliver the output for the buck converter.

Ground Connections (A_{GND} and P_{GND})

P_{GND} (power ground) should be externally connected to A_{GND} (analog ground). The layout of the printed circuit board should be such that the inductance separating the A_{GND} and P_{GND} should be a minimum. Transient differences due to inductance effects between these two pins should not exceed 0.5 V.

Control and Drive Supply Voltage Input (V_{DRV} , V_{CIN})

V_{CIN} is the bias supply for the logic control circuitry of the IC. V_{DRVx} is the bias supply for the low-side gate drivers. It is recommended to separate these pins through a resistor. This creates a low pass filtering effect to avoid coupling of high frequency gate drive noise into the logic circuitry.

ELECTRICAL CHARACTERISTICS ($V_{OUT} = 2\text{ V}$, $V_{CIN} = V_{DRVx} = 5\text{ V}$, $L = 4.7\text{ }\mu\text{H}$, unless otherwise noted)

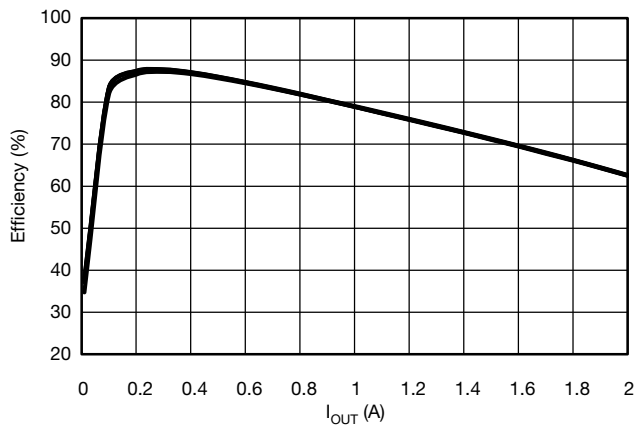

Fig. 6 - Efficiency vs. I_{OUT}
 $V_{IN} = 8\text{ V}$, $f_{SW} = 1\text{ MHz}$

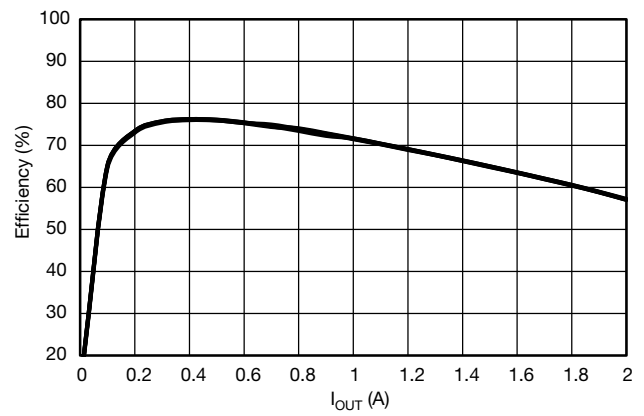

Fig. 9 - Efficiency vs. I_{OUT}
 $V_{IN} = 10\text{ V}$, $f_{SW} = 5\text{ MHz}$

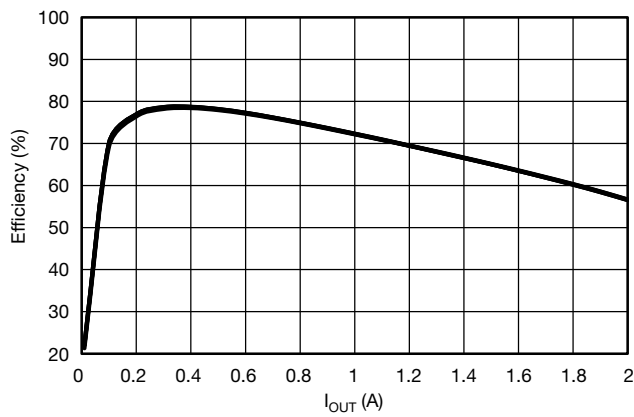

Fig. 7 - Efficiency vs. I_{OUT}
 $V_{IN} = 8\text{ V}$, $f_{SW} = 5\text{ MHz}$

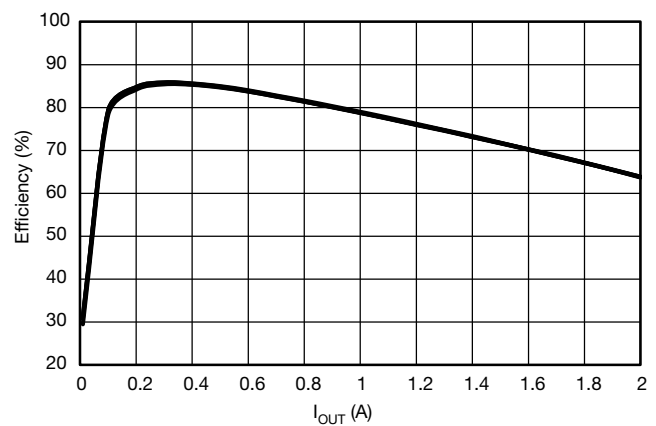

Fig. 10 - Efficiency vs. I_{OUT}
 $V_{IN} = 12\text{ V}$, $f_{SW} = 1\text{ MHz}$

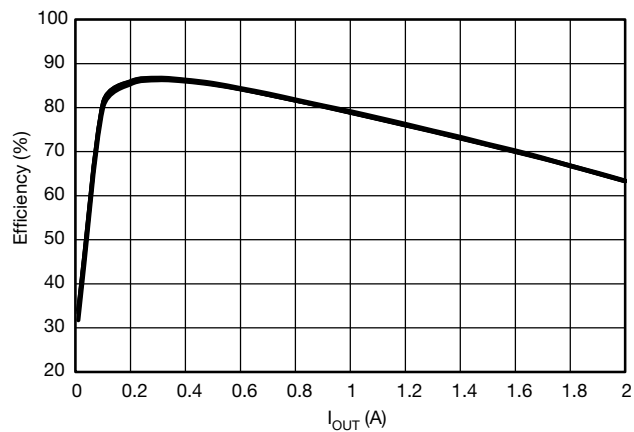

Fig. 8 - Efficiency vs. I_{OUT}
 $V_{IN} = 10\text{ V}$, $f_{SW} = 1\text{ MHz}$

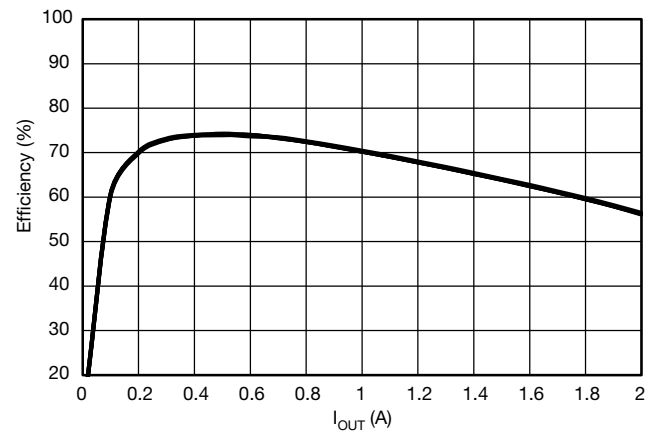

Fig. 11 - Efficiency vs. I_{OUT}
 $V_{IN} = 12\text{ V}$, $f_{SW} = 5\text{ MHz}$

ELECTRICAL CHARACTERISTICS ($V_{OUT} = 2\text{ V}$, $V_{CIN} = V_{DRVx} = 5\text{ V}$, $L = 4.7\text{ }\mu\text{H}$, unless otherwise noted)

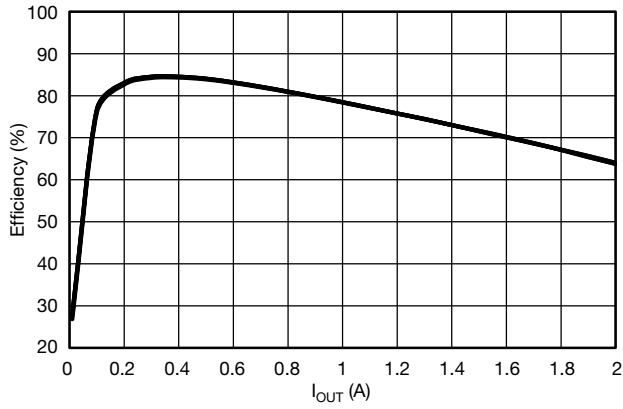

Fig. 12 - Efficiency vs. I_{OUT}
 $V_{IN} = 15\text{ V}$, $f_{SW} = 1\text{ MHz}$

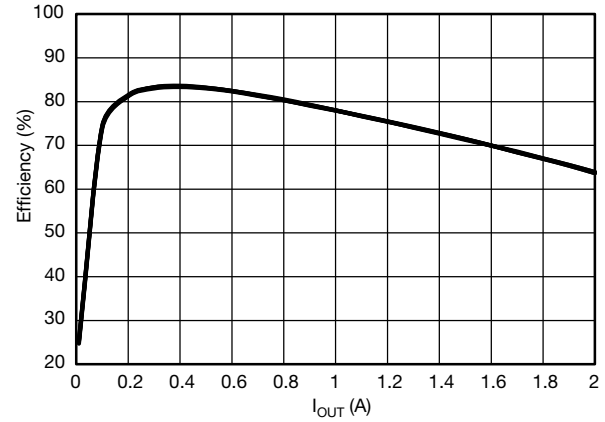

Fig. 14 - Efficiency vs. I_{OUT}
 $V_{IN} = 18\text{ V}$, $f_{SW} = 1\text{ MHz}$

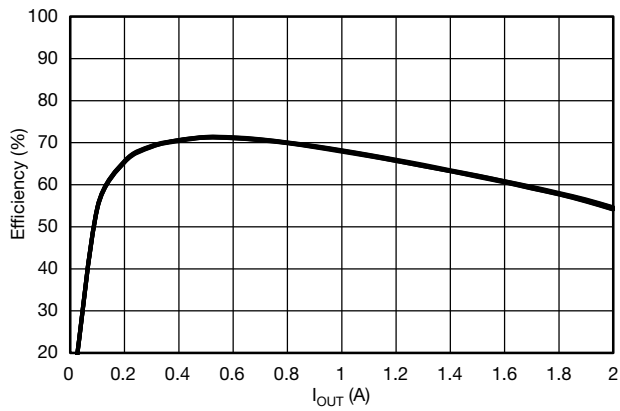

Fig. 13 - Efficiency vs. I_{OUT}
 $V_{IN} = 15\text{ V}$, $f_{SW} = 5\text{ MHz}$

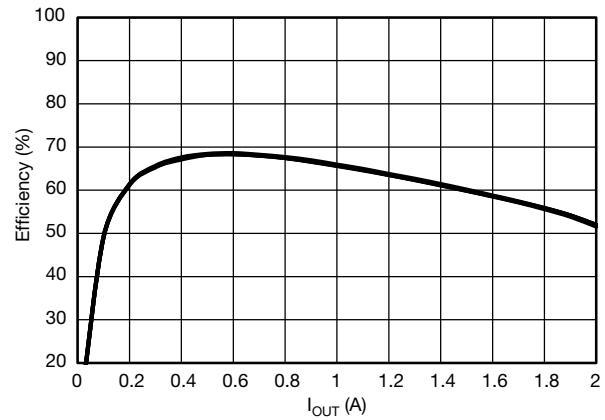

Fig. 15 - Efficiency vs. I_{OUT}
 $V_{IN} = 18\text{ V}$, $f_{SW} = 5\text{ MHz}$

ELECTRICAL CHARACTERISTICS

($V_{IN} = 15\text{ V}$, $V_{OUT} = 2\text{ V}$, $V_{CIN} = V_{DRVx} = 5\text{ V}$, $I_{OUT} = 0.5\text{ A}$, $f_{SW} = 5\text{ MHz}$, $L = 4.7\text{ }\mu\text{H}$, unless otherwise noted)

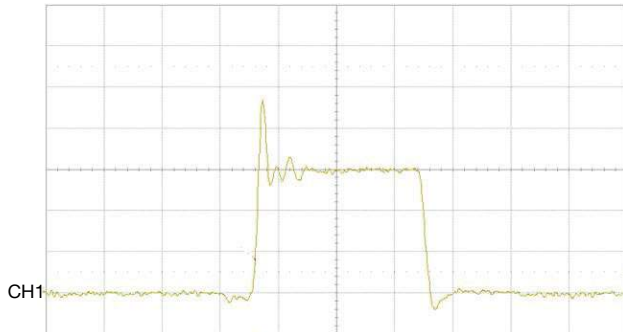

Fig. 16 - Output Switching Waveform
CH1 (YLLW) = SW1 (5 V/div.), Time = 10 ns/div.

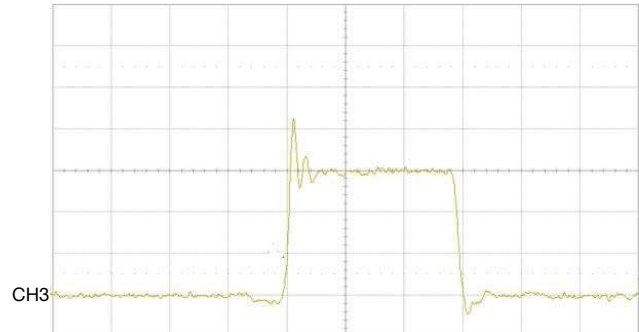

Fig. 19 - Output Switching Waveform
CH3 (YLLW) = SW3 (5 V/div.), Time = 10 ns/div.

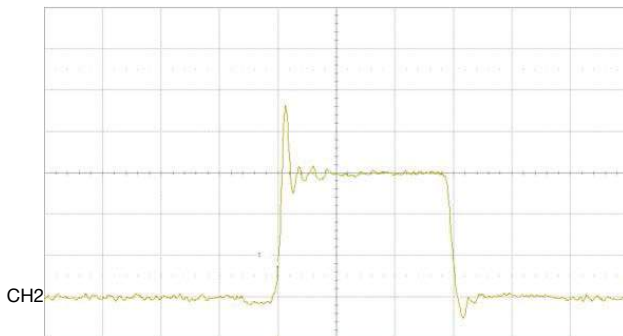

Fig. 17 - Output Switching Waveform
CH2 (YLLW) = SW2 (5 V/div.), Time = 10 ns/div.

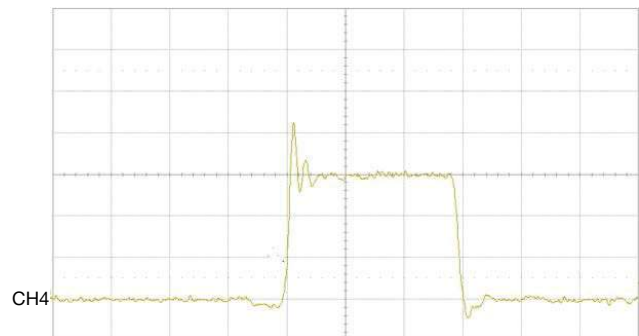

Fig. 20 - Output Switching Waveform
CH4 (YLLW) = SW4 (5 V/div.), Time = 10 ns/div.

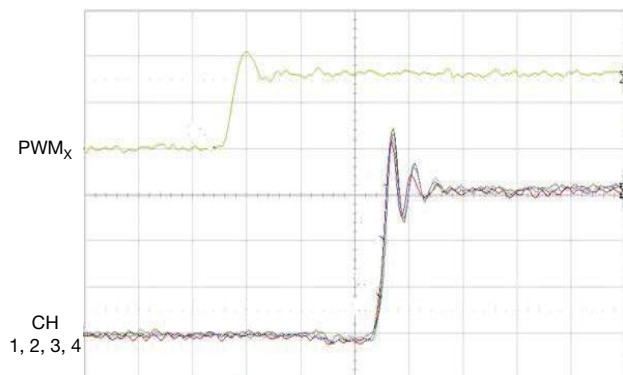

Fig. 18 - Propagation Delay - Rising (all channels)
CH1 = (VLT) = SW1 (5 V/div.), CH2 = (RED) = SW2 (5 V/div.),
CH3 = (BLU) = SW3 (5 V/div.), CH4 = (GRN) = SW4 (5 V/div.),
PWM_x (YLLW) = 2 V/div., Time = 5 ns/div.

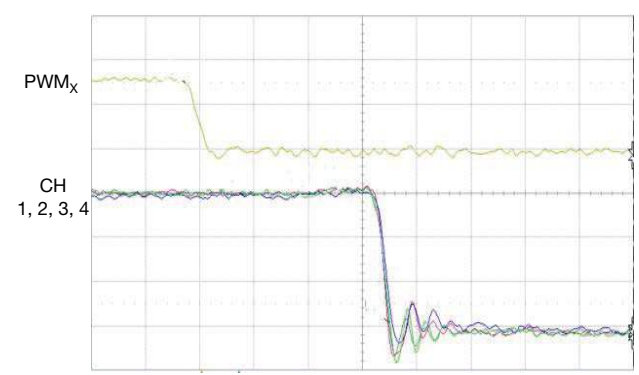

Fig. 21 - Propagation Delay - Falling (all channels)
CH1 = (VLT) = SW1 (5 V/div.), CH2 = (RED) = SW2 (5 V/div.),
CH3 = (BLU) = SW3 (5 V/div.), CH4 = (GRN) = SW4 (5 V/div.),
PWM_x (YLLW) = 2 V/div., Time = 5 ns/div.



DEMO BOARD SCHEMATIC

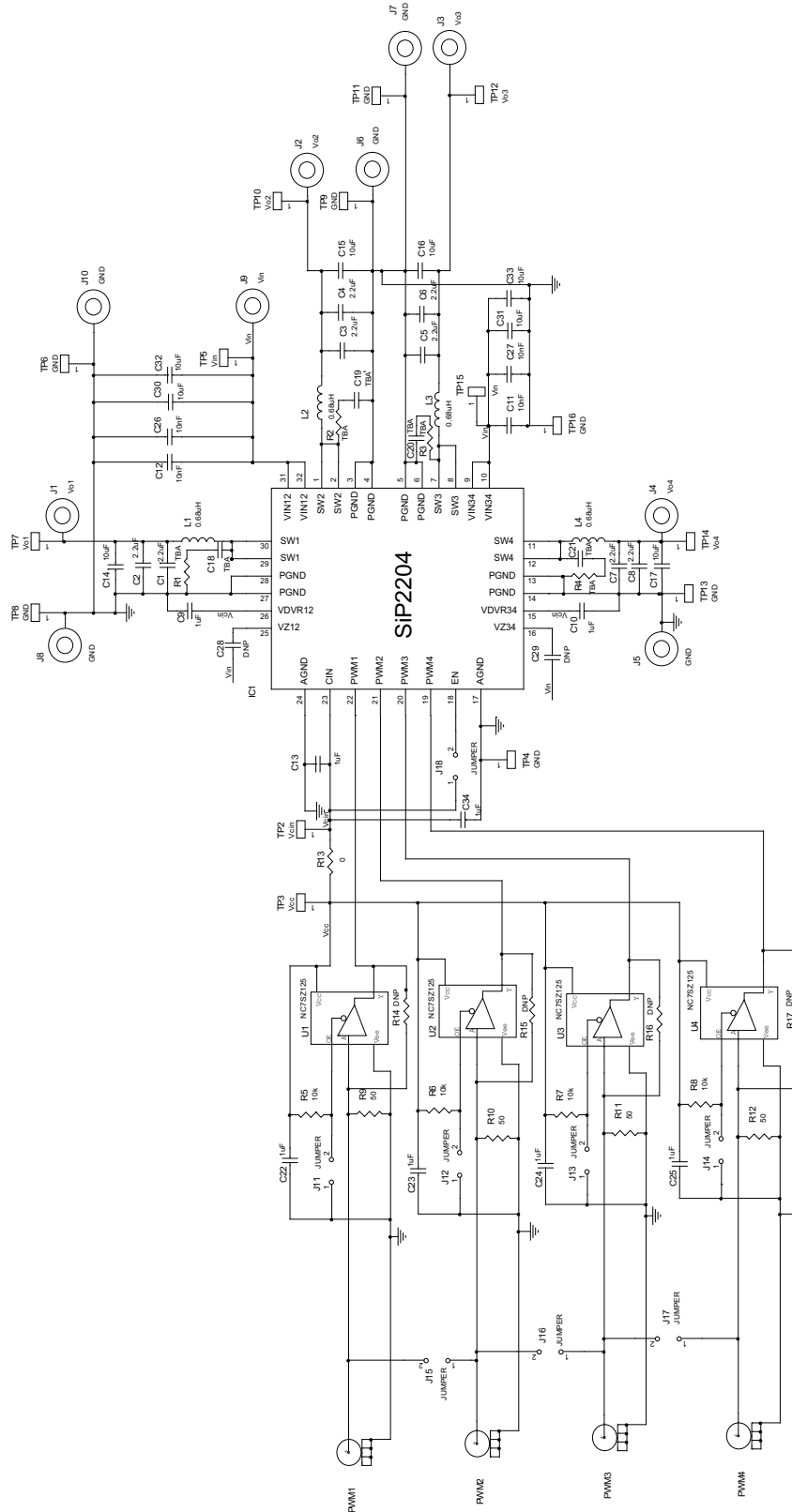

Fig. 22 - Reference Board Schematic for SiP2204



| BILL OF MATERIALS | | | | |
|-------------------|------|--|--------------------|---------------|
| ITEM | QTY. | REFERENCE | COMPONENT VALUE | PCB FOOTPRINT |
| 1 | 8 | C1, C2, C3, C4, C5, C6, C7, C8 | 2.2 μ F, 6.3 V | 0805 |
| 2 | 4 | C9, C10, C13, C34 | 1 μ F, 6.3 V | 0402 |
| 3 | 4 | C11, C12, C26, C27 | 10 nF, 25 V | 0805 |
| 4 | 4 | C14, C15, C16, C17 | 10 μ F, 6.3 V | 1206 |
| 5 | 4 | C18, C19, C20, C21 | DNP | 0603 |
| 6 | 4 | C22, C23, C24, C25 | 1 μ F, 10 V | 0603 |
| 7 | 2 | C28, C29 | DNP | 0603 |
| 8 | 4 | C30, C31, C32, C33 | 10 μ F, 25 V | 1210 |
| 9 | 1 | IC1 | SiP2204 | QFN5x5-32 |
| 10 | 1 | J1 | V _{O1} | Banana |
| 11 | 1 | J2 | V _{O2} | Banana |
| 12 | 1 | J3 | V _{O3} | Banana |
| 13 | 1 | J4 | V _{O4} | Banana |
| 14 | 5 | J5, J6, J7, J8, J10 | GND | Banana |
| 15 | 1 | J9 | V _{IN} | Banana |
| 16 | 8 | J11, J12, J13, J14, J15, J16, J17, J18 | JUMPER | Jumper2 |
| 17 | 4 | L1, L2, L3, L4 | 4.7 μ H | IHLP2525A |
| 18 | 4 | PWM1, PWM2, PWM3, PWM4 | SMA connect | SMA |
| 19 | 4 | R1, R2, R3, R4 | DNP | R0805-Vishay |
| 20 | 4 | R5, R6, R7, R8 | 10 k Ω | R0805-Vishay |
| 21 | 4 | R9, R10, R11, R12 | 50 Ω | R1206-Vishay |
| 22 | 1 | R13 | 0 Ω | R0805-Vishay |
| 23 | 4 | R14, R15, R16, R17 | DNP | R0603-Vishay |
| 24 | 1 | TP2 | V _{CIN} | TP30 |
| 25 | 1 | TP3 | V _{CC} | TP30 |
| 26 | 7 | TP4, TP6, TP8, TP9, TP11, TP13, TP16 | GND | TP30 |
| 27 | 2 | TP5, TP15 | V _{IN} | TP30 |
| 28 | 1 | TP7 | V _{O1} | TP30 |
| 29 | 1 | TP10 | V _{O2} | TP30 |
| 30 | 1 | TP12 | V _{O3} | TP30 |
| 31 | 1 | TP14 | V _{O4} | TP30 |
| 32 | 4 | U1, U2, U3, U4 | NC7SZ125 | SOT23-5 |

PCB LAYOUT OF REFERENCE BOARD

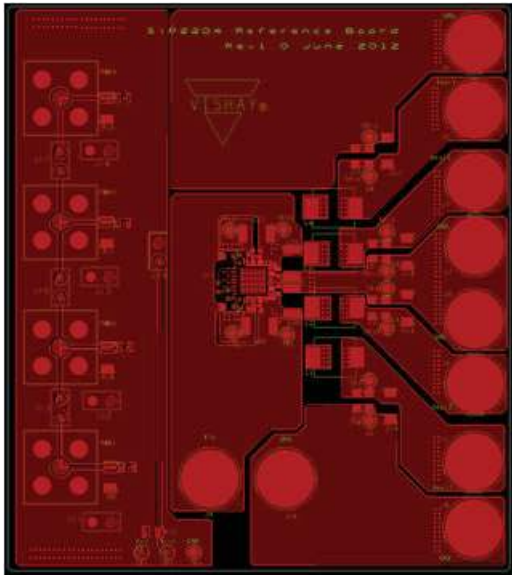

Fig. 23 - Top Layer

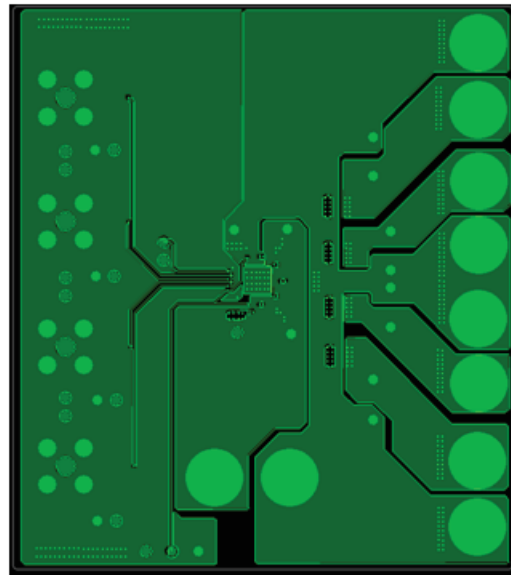

Fig. 25 - Inner 2

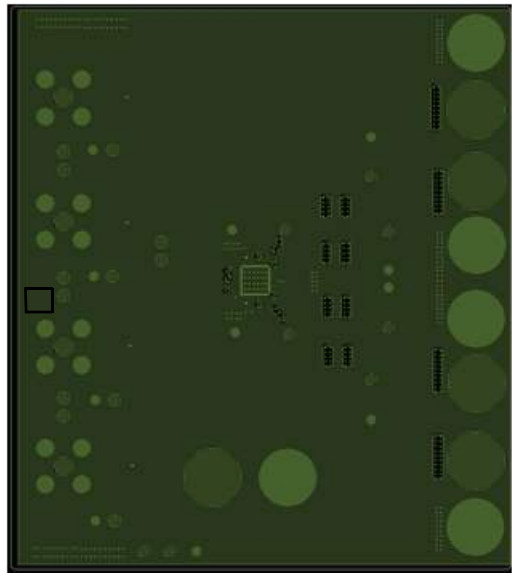

Fig. 24 - Inner 1

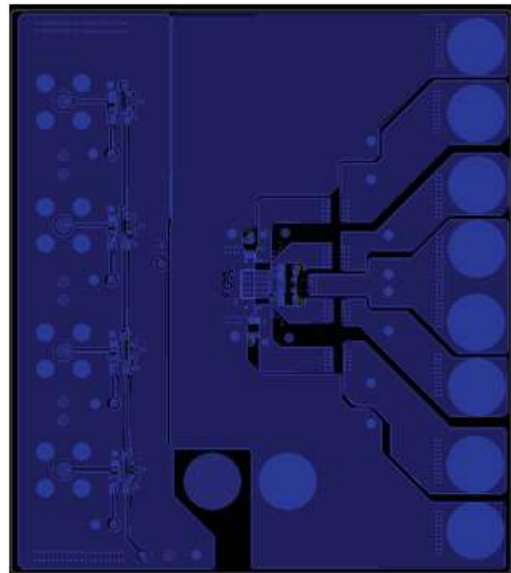

Fig. 26 - Bottom



| PRODUCT SUMMARY | |
|------------------------------------|---|
| Part number | SiP2204 |
| Description | 0.5 A power stage, 10 V _{IN} to 24 V _{IN} , 3.3 V and 5.5 V PWM with - mode |
| Input voltage min. (V) | 10 |
| Input voltage max. (V) | 24 |
| Continuous current rating max. (A) | 0.5 |
| Switch frequency max. (kHz) | 5000 |
| Enable (yes / no) | YES |
| Monitoring features | - |
| Protection | UVLO |
| Light load mode | - |
| Pulse-width modulation (V) | 3.3 and 5 |
| Package type | QFN32-55 |
| Package size (W, L, H) (mm) | 5.0 x 5.0 x 0.85 |
| Status code | 2 |
| Product type | VRPower (DrMOS) |
| Applications | Computer, industrial, networking |

Vishay Siliconix maintains worldwide manufacturing capability. Products may be manufactured at one of several qualified locations. Reliability data for Silicon Technology and Package Reliability represent a composite of all qualified locations. For related documents such as package / tape drawings, part marking, and reliability data, see www.vishay.com/ppg?62619.

QFN32 5 x 5 Case Outline

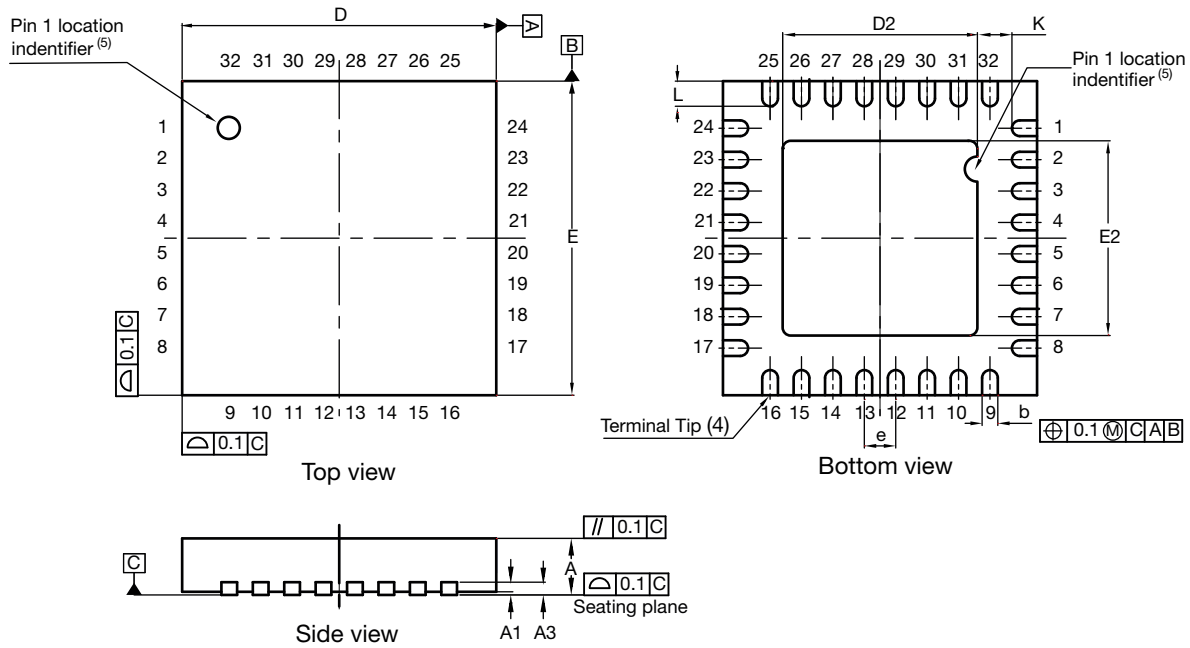

| DIM. | MILLIMETERS | | | INCHES | | |
|-------------------|-------------|------|------|------------|-------|-------|
| | MIN. | NOM. | MAX. | MIN. | NOM. | MAX. |
| A | 0.75 | 0.85 | 0.95 | 0.029 | 0.033 | 0.037 |
| A1 | 0.00 | - | 0.05 | 0.000 | - | 0.002 |
| A3 | 0.20 ref. | | | 0.008 ref. | | |
| b | 0.18 | 0.25 | 0.30 | 0.007 | 0.010 | 0.012 |
| D | 5.00 BSC | | | 0.197 BSC | | |
| D2 | 3.00 | 3.10 | 3.20 | 0.118 | 0.122 | 0.126 |
| e | 0.50 BSC | | | 0.020 BSC | | |
| E | 5.00 BSC | | | 0.197 BSC | | |
| E2 | 3.00 | 3.10 | 3.20 | 0.118 | 0.122 | 0.126 |
| K | 0.20 | - | - | 0.008 | - | - |
| L | 0.30 | 0.40 | 0.50 | 0.012 | 0.016 | 0.020 |
| N ⁽³⁾ | 32 | | | 32 | | |
| Nd ⁽³⁾ | 8 | | | 8 | | |
| Ne ⁽³⁾ | 8 | | | 8 | | |

Notes

- (1) Use millimeters as the primary measurement
- (2) Dimensioning and tolerances conform to ASME Y14.5M. - 1994
- (3) N is the number of terminals,
Nd is the number of terminals in X-direction and
Ne is the number of terminals in Y-direction.
- (4) Dimension b applies to plated terminal and is measured between 0.15 mm and 0.30 mm from terminal tip
- (5) The pin #1 identifier must be existed on the top surface of the package by using indentation mark or other feature of package body
- (6) Package warpage max. 0.05 mm

S14-2079-Rev. A, 20-Oct-14
DWG: 6027

Recommended Land Pattern QFN32 5 x 5

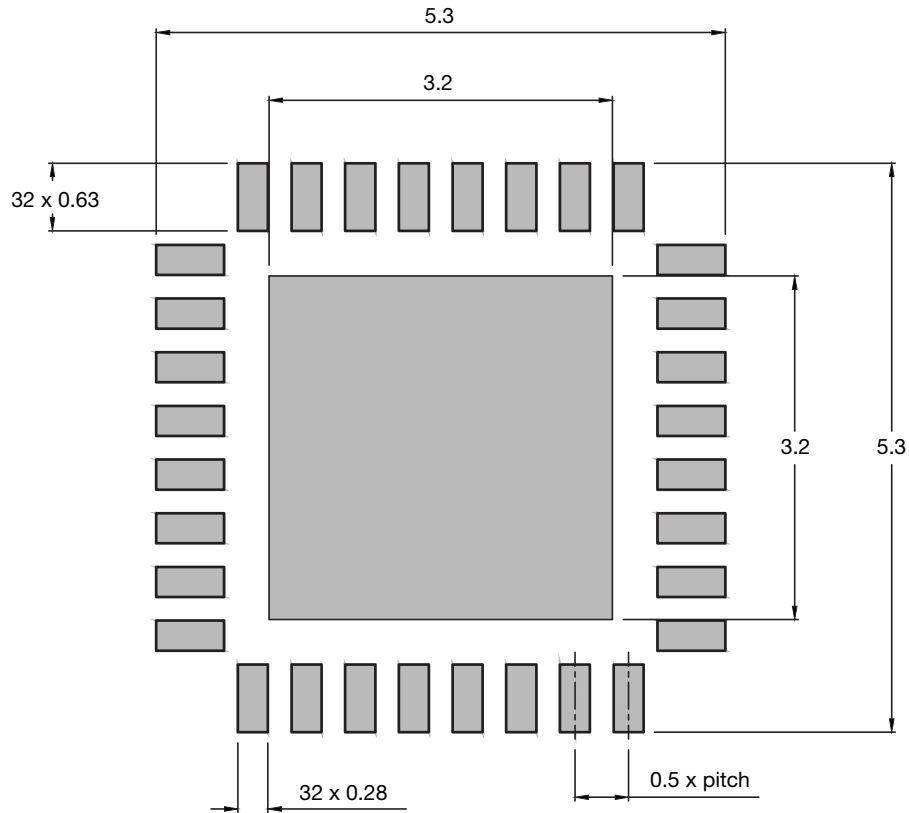

Dimensions are in millimeters



Disclaimer

ALL PRODUCT, PRODUCT SPECIFICATIONS AND DATA ARE SUBJECT TO CHANGE WITHOUT NOTICE TO IMPROVE RELIABILITY, FUNCTION OR DESIGN OR OTHERWISE.

Vishay Intertechnology, Inc., its affiliates, agents, and employees, and all persons acting on its or their behalf (collectively, "Vishay"), disclaim any and all liability for any errors, inaccuracies or incompleteness contained in any datasheet or in any other disclosure relating to any product.

Vishay makes no warranty, representation or guarantee regarding the suitability of the products for any particular purpose or the continuing production of any product. To the maximum extent permitted by applicable law, Vishay disclaims (i) any and all liability arising out of the application or use of any product, (ii) any and all liability, including without limitation special, consequential or incidental damages, and (iii) any and all implied warranties, including warranties of fitness for particular purpose, non-infringement and merchantability.

Statements regarding the suitability of products for certain types of applications are based on Vishay's knowledge of typical requirements that are often placed on Vishay products in generic applications. Such statements are not binding statements about the suitability of products for a particular application. It is the customer's responsibility to validate that a particular product with the properties described in the product specification is suitable for use in a particular application. Parameters provided in datasheets and / or specifications may vary in different applications and performance may vary over time. All operating parameters, including typical parameters, must be validated for each customer application by the customer's technical experts. Product specifications do not expand or otherwise modify Vishay's terms and conditions of purchase, including but not limited to the warranty expressed therein.

Hyperlinks included in this datasheet may direct users to third-party websites. These links are provided as a convenience and for informational purposes only. Inclusion of these hyperlinks does not constitute an endorsement or an approval by Vishay of any of the products, services or opinions of the corporation, organization or individual associated with the third-party website. Vishay disclaims any and all liability and bears no responsibility for the accuracy, legality or content of the third-party website or for that of subsequent links.

Except as expressly indicated in writing, Vishay products are not designed for use in medical, life-saving, or life-sustaining applications or for any other application in which the failure of the Vishay product could result in personal injury or death. Customers using or selling Vishay products not expressly indicated for use in such applications do so at their own risk. Please contact authorized Vishay personnel to obtain written terms and conditions regarding products designed for such applications.

No license, express or implied, by estoppel or otherwise, to any intellectual property rights is granted by this document or by any conduct of Vishay. Product names and markings noted herein may be trademarks of their respective owners.