

## DRV8830 Low-Voltage Motor Driver With Serial Interface

### 1 Features

- H-Bridge Voltage-Controlled Motor Driver
  - Drives DC Motor, One Winding of a Stepper Motor, or Other Actuators/Loads
  - Efficient PWM Voltage Control for Constant Motor Speed With Varying Supply Voltages
  - Low MOSFET On-Resistance: HS + LS 450 mΩ
- 1-A Maximum DC/RMS or Peak Drive Current
- 2.75-V to 6.8-V Operating Supply Voltage Range
- 300-nA (Typical) Sleep Mode Current
- Serial I<sup>2</sup>C-Compatible Interface
- Multiple Address Selections Allow Up to 9 Devices on One I<sup>2</sup>C Bus
- Current Limit Circuit and Fault Output
- Thermally-Enhanced Surface Mount Packages

### 2 Applications

- Battery-Powered:
  - Printers
  - Toys
  - Robotics
  - Cameras
  - Phones
- Small Actuators, Pumps, and so forth

### 3 Description

The DRV8830 device provides an integrated motor driver solution for battery-powered toys, printers, and other low-voltage or battery-powered motion control applications. The device has one H-bridge driver, and can drive one DC motor or one winding of a stepper motor, as well as other loads like solenoids. The output driver block consists of N-channel and P-channel power MOSFETs configured as an H-bridge to drive the motor winding.

Provided with sufficient PCB heatsinking, the DRV8830 can supply up to 1-A of DC/RMS or peak output current. It operates on power supply voltages from 2.75 V to 6.8 V.

To maintain constant motor speed over varying battery voltages while maintaining long battery life, a PWM voltage regulation method is provided. The output voltage is programmed through an I<sup>2</sup>C-compatible interface, using an internal voltage reference and DAC.

Internal protection functions are provided for over current protection, short-circuit protection, undervoltage lockout, and overtemperature protection.

The DRV8830 is available in a tiny 3-mm × 3-mm 10-pin VSON package and HVSSOP package with PowerPAD™ (Eco-friendly: RoHS & no Sb/Br).

#### Device Information<sup>(1)</sup>

| PART NUMBER | PACKAGE     | BODY SIZE (NOM)   |
|-------------|-------------|-------------------|
| DRV8830     | HVSSOP (10) | 3.00 mm × 3.00 mm |
|             | VSON (10)   |                   |

(1) For all available packages, see the orderable addendum at the end of the data sheet.

#### Simplified Schematic

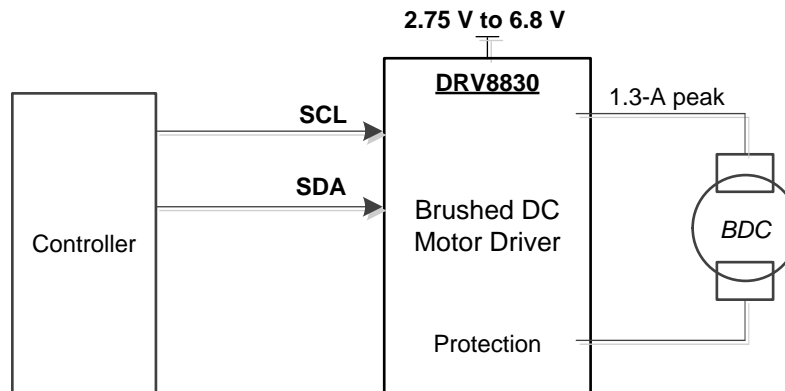

## Table of Contents

|  |           |  |           |
|--|-----------|--|-----------|
| <b>1 Features</b> .....                        | <b>1</b>  | 7.6 Register Maps .....                          | <b>13</b> |
| <b>2 Applications</b> .....                    | <b>1</b>  | <b>8 Application and Implementation</b> .....    | <b>15</b> |
| <b>3 Description</b> .....                     | <b>1</b>  | 8.1 Application Information.....                 | <b>15</b> |
| <b>4 Revision History</b> .....                | <b>2</b>  | 8.2 Typical Application .....                    | <b>15</b> |
| <b>5 Pin Configuration and Functions</b> ..... | <b>3</b>  | <b>9 Power Supply Recommendations</b> .....      | <b>19</b> |
| <b>6 Specifications</b> .....                  | <b>3</b>  | 9.1 Power Supervisor.....                        | <b>19</b> |
| 6.1 Absolute Maximum Ratings .....             | <b>3</b>  | 9.2 Bulk Capacitance .....                       | <b>19</b> |
| 6.2 ESD Ratings.....                           | <b>4</b>  | <b>10 Layout</b> .....                           | <b>20</b> |
| 6.3 Recommended Operating Conditions.....      | <b>4</b>  | 10.1 Layout Guidelines .....                     | <b>20</b> |
| 6.4 Thermal Information .....                  | <b>4</b>  | 10.2 Layout Example .....                        | <b>20</b> |
| 6.5 Electrical Characteristics.....            | <b>5</b>  | 10.3 Thermal Considerations .....                | <b>20</b> |
| 6.6 I <sup>2</sup> C Timing Requirements.....  | <b>6</b>  | <b>11 Device and Documentation Support</b> ..... | <b>21</b> |
| 6.7 Typical Characteristics .....              | <b>7</b>  | 11.1 Documentation Support .....                 | <b>21</b> |
| <b>7 Detailed Description</b> .....            | <b>8</b>  | 11.2 Community Resources.....                    | <b>21</b> |
| 7.1 Overview .....                             | <b>8</b>  | 11.3 Trademarks .....                            | <b>21</b> |
| 7.2 Functional Block Diagram .....             | <b>8</b>  | 11.4 Electrostatic Discharge Caution.....        | <b>21</b> |
| 7.3 Feature Description.....                   | <b>8</b>  | 11.5 Glossary .....                              | <b>21</b> |
| 7.4 Device Functional Modes.....               | <b>11</b> | <b>12 Mechanical, Packaging, and Orderable</b>   |           |
| 7.5 Programming.....                           | <b>12</b> | <b>Information</b> .....                         | <b>21</b> |

## 4 Revision History

NOTE: Page numbers for previous revisions may differ from page numbers in the current version.

| <b>Changes from Revision F (February 2012) to Revision G</b>  | <b>Page</b> |
|---|-------------|
| <ul style="list-style-type: none"> <li>Added <i>Pin Configuration and Functions</i> section, <i>ESD Ratings</i> table, <i>Feature Description</i> section, <i>Device Functional Modes</i>, <i>Application and Implementation</i> section, <i>Power Supply Recommendations</i> section, <i>Layout</i> section, <i>Device and Documentation Support</i> section, and <i>Mechanical, Packaging, and Orderable Information</i> section .....</li> </ul> | <b>1</b>    |

## 5 Pin Configuration and Functions



The HVSSOP package has a PowerPAD.

### Pin Functions

| PIN    |     | TYPE <sup>(1)</sup> | DESCRIPTION             | EXTERNAL COMPONENTS OR CONNECTIONS   |
|--------|-----|---------------------|-------------------------|--|
| NAME   | NO. |                     |                         |  |
| A0     | 7   | I                   | Address set 0           | Connect to GND, VCC, or open to set I <sup>2</sup> C base address. See serial interface description. |
| A1     | 8   | I                   | Address set 1           |  |
| FAULTn | 6   | OD                  | Fault output            | Open-drain output driven low if fault condition present  |
| GND    | 5   | —                   | Device ground           |  |
| ISENSE | 2   | IO                  | Current sense resistor  | Connect current sense resistor to GND. Resistor value sets current limit level.                      |
| OUT1   | 3   | O                   | Bridge output 1         | Connect to motor winding   |
| OUT2   | 1   | O                   | Bridge output 2         |  |
| SCL    | 10  | I                   | Serial clock            | Clock line of I <sup>2</sup> C serial bus  |
| SDA    | 9   | IO                  | Serial data             | Data line of I <sup>2</sup> C serial bus   |
| VCC    | 4   | —                   | Device and motor supply | Bypass to GND with a 0.1- $\mu$ F (minimum) ceramic capacitor.                                       |

(1) Directions: I = input, O = output, OZ = tri-state output, OD = open-drain output, IO = input/output

## 6 Specifications

### 6.1 Absolute Maximum Ratings

over operating free-air temperature range (unless otherwise noted)<sup>(1)(2)</sup>

|                  |  | MIN                                     | MAX | UNIT |
|------------------|--|---|-----|------|
| VCC              | Power supply voltage                                 | -0.3                                    | 7   | V    |
|                  | Input pin voltage                                    | -0.5                                    | 7   | V    |
|                  | Peak motor drive output current <sup>(3)</sup>       | Internally limited                      |     | A    |
|                  | Continuous motor drive output current <sup>(3)</sup> | -1                                      | 1   | A    |
|                  | Continuous total power dissipation                   | See <a href="#">Thermal Information</a> |     |      |
| T <sub>J</sub>   | Operating virtual junction temperature               | -40                                     | 150 | °C   |
| T <sub>stg</sub> | Storage temperature                                  | -60                                     | 150 |      |

- (1) Stresses beyond those listed under *Absolute Maximum Ratings* may cause permanent damage to the device. These are stress ratings only, which do not imply functional operation of the device at these or any other conditions beyond those indicated under *Recommended Operating Conditions*. Exposure to absolute-maximum-rated conditions for extended periods may affect device reliability.
- (2) All voltage values are with respect to network ground terminal.
- (3) Power dissipation and thermal limits must be observed.

## 6.2 ESD Ratings

|                    |                         |  | VALUE | UNIT |
|--------------------|-------------------------|--|-------|------|
| V <sub>(ESD)</sub> | Electrostatic discharge | Human body model (HBM), per ANSI/ESDA/JEDEC JS-001 <sup>(1)</sup>              | ±2000 | V    |
|                    |                         | Charged-device model (CDM), per JEDEC specification JESD22-C101 <sup>(2)</sup> | ±1000 |      |

(1) JEDEC document JEP155 states that 500-V HBM allows safe manufacturing with a standard ESD control process.

(2) JEDEC document JEP157 states that 250-V CDM allows safe manufacturing with a standard ESD control process.

## 6.3 Recommended Operating Conditions

over operating free-air temperature range (unless otherwise noted)

|                  |   | MIN  | MAX | UNIT |
|------------------|---|------|-----|------|
| V <sub>CC</sub>  | Motor power supply voltage                                | 2.75 | 6.8 | V    |
| I <sub>OUT</sub> | Continuous or peak H-bridge output current <sup>(1)</sup> | 0    | 1   | A    |

(1) Power dissipation and thermal limits must be observed.

## 6.4 Thermal Information

| THERMAL METRIC <sup>(1)</sup> |  | DRV8830      |            | UNIT |
|-------------------------------|--|--------------|------------|------|
|                               |  | DGQ (HVSSOP) | DRC (VSON) |      |
|                               |  | 10 PINS      | 10 PINS    |      |
| R <sub>θJA</sub>              | Junction-to-ambient thermal resistance       | 69.3         | 50.2       | °C/W |
| R <sub>θJC(top)</sub>         | Junction-to-case (top) thermal resistance    | 63.5         | 78.4       | °C/W |
| R <sub>θJB</sub>              | Junction-to-board thermal resistance         | 51.6         | 18.8       | °C/W |
| ψ <sub>JT</sub>               | Junction-to-top characterization parameter   | 1.5          | 1.1        | °C/W |
| ψ <sub>JB</sub>               | Junction-to-board characterization parameter | 23.2         | 17.9       | °C/W |
| R <sub>θJB</sub>              | Junction-to-case (bottom) thermal resistance | 9.5          | 5.1        | °C/W |

(1) For more information about traditional and new thermal metrics, see the *Semiconductor and IC Package Thermal Metrics* application report, [SPRA953](#).

## 6.5 Electrical Characteristics

 $V_{CC} = 2.75\text{ V to }6.8\text{ V}$ ,  $T_A = -40^\circ\text{C to }85^\circ\text{C}$  (unless otherwise noted)

| PARAMETER                           | TEST CONDITIONS  | MIN   | TYP                  | MAX                 | UNIT          |                  |
|-------------------------------------|--|---|----------------------|---------------------|---------------|------------------|
| <b>POWER SUPPLIES</b>               |  |   |                      |                     |               |                  |
| $I_{VCC}$                           | VCC operating supply current                             | $V_{CC} = 5\text{ V}$   | 1.4                  | 2                   | mA            |                  |
| $I_{VCCQ}$                          | VCC sleep mode supply current                            | $V_{CC} = 5\text{ V}$ , $T_A = 25^\circ\text{C}$  | 0.3                  | 1                   | $\mu\text{A}$ |                  |
| $V_{UVLO}$                          | VCC undervoltage lockout voltage                         | $V_{CC}$ rising   | 2.575                | 2.75                | V             |                  |
|                                     |  | $V_{CC}$ falling  | 2.47                 |                     |               |                  |
| <b>LOGIC-LEVEL INPUTS</b>           |  |   |                      |                     |               |                  |
| $V_{IL}$                            | Input low voltage  | $0.25 \times V_{CC}$  | $0.38 \times V_{CC}$ |                     | V             |                  |
| $V_{IH}$                            | Input high voltage                                       |   | $0.46 \times V_{CC}$ | $0.5 \times V_{CC}$ | V             |                  |
| $V_{HYS}$                           | Input hysteresis   |   | $0.08 \times V_{CC}$ |                     | V             |                  |
| $I_{IL}$                            | Input low current  | $V_{IN} = 0$  | -10                  | 10                  | $\mu\text{A}$ |                  |
| $I_{IH}$                            | Input high current                                       | $V_{IN} = 3.3\text{ V}$   |                      | 50                  | $\mu\text{A}$ |                  |
| <b>LOGIC-LEVEL OUTPUTS (FAULTn)</b> |  |   |                      |                     |               |                  |
| $V_{OL}$                            | Output low voltage                                       | $I_{OL} = 4\text{ mA}$ , $V_{CC} = 5\text{ V}$  | 0.5                  |                     | V             |                  |
| <b>H-BRIDGE FETS</b>                |  |   |                      |                     |               |                  |
| $R_{DS(ON)}$                        | HS FET on resistance                                     | $V_{CC} = 5\text{ V}$ , $I_O = 0.8\text{ A}$ , $T_J = 85^\circ\text{C}$                                       | 290                  | 400                 | m $\Omega$    |                  |
|                                     |  | $V_{CC} = 5\text{ V}$ , $I_O = 0.8\text{ A}$ , $T_J = 25^\circ\text{C}$                                       | 250                  |                     |               |                  |
| $R_{DS(ON)}$                        | LS FET on resistance                                     | $V_{CC} = 5\text{ V}$ , $I_O = 0.8\text{ A}$ , $T_J = 85^\circ\text{C}$                                       | 230                  | 320                 | m $\Omega$    |                  |
|                                     |  | $V_{CC} = 5\text{ V}$ , $I_O = 0.8\text{ A}$ , $T_J = 25^\circ\text{C}$                                       | 200                  |                     |               |                  |
| $I_{OFF}$                           | Off-state leakage current                                |   | -20                  | 20                  | $\mu\text{A}$ |                  |
| <b>MOTOR DRIVER</b>                 |  |   |                      |                     |               |                  |
| $t_R$                               | Rise time  | $V_{CC} = 3\text{ V}$ , load = 4 $\Omega$   | 50                   | 300                 | ns            |                  |
| $t_F$                               | Fall time  | $V_{CC} = 3\text{ V}$ , load = 4 $\Omega$   | 50                   | 300                 | ns            |                  |
| $f_{SW}$                            | Internal PWM frequency                                   |   | 44.5                 |                     | kHz           |                  |
| <b>PROTECTION CIRCUITS</b>          |  |   |                      |                     |               |                  |
| $I_{OCP}$                           | Overcurrent protection trip level                        |   | 1.3                  | 3                   | A             |                  |
| $t_{OCP}$                           | OCP deglitch time  |   | 2                    |                     | $\mu\text{s}$ |                  |
| $T_{TSD}$                           | Thermal shutdown temperature                             | Die temperature <sup>(1)</sup>  | 150                  | 160                 | 180           | $^\circ\text{C}$ |
| <b>VOLTAGE CONTROL</b>              |  |   |                      |                     |               |                  |
| $V_{REF}$                           | Reference output voltage                                 |   | 1.235                | 1.285               | 1.335         | V                |
| $\Delta V_{LINE}$                   | Line regulation  | $V_{CC} = 3.3\text{ V to }6\text{ V}$ , $V_{OUT} = 3\text{ V}$ , <sup>(1)</sup><br>$I_{OUT} = 500\text{ mA}$  |                      | $\pm 1\%$           |               |                  |
| $\Delta V_{LOAD}$                   | Load regulation  | $V_{CC} = 5\text{ V}$ , $V_{OUT} = 3\text{ V}$ ,<br>$I_{OUT} = 200\text{ mA to }800\text{ mA}$ <sup>(1)</sup> |                      | $\pm 1\%$           |               |                  |
| <b>CURRENT LIMIT</b>                |  |   |                      |                     |               |                  |
| $V_{ILIM}$                          | Current limit sense voltage                              |   | 160                  | 200                 | 240           | mV               |
| $t_{ILIM}$                          | Current limit fault deglitch time                        |   |                      | 275                 |               | ms               |
| $R_{ISEN}$                          | Current limit sense resistance (external resistor value) |   | 0                    | 1                   | $\Omega$      |                  |

(1) Not production tested.

## 6.6 I<sup>2</sup>C Timing Requirements<sup>(1)</sup>

V<sub>CC</sub> = 2.75 V to 6.8 V, T<sub>A</sub> = -40°C to 85°C (unless otherwise noted)

|                        |   | STANDARD MODE |     |      | FAST MODE               |     |     | UNIT |
|------------------------|---|---------------|-----|------|-------------------------|-----|-----|------|
|                        |   | MIN           | NOM | MAX  | MIN                     | NOM | MAX |      |
| f <sub>scl</sub>       | I <sup>2</sup> C clock frequency                            | 0             |     | 100  | 0                       |     | 400 | kHz  |
| t <sub>sch</sub>       | I <sup>2</sup> C clock high time                            | 4             |     |      | 0.6                     |     |     | μs   |
| t <sub>scl</sub>       | I <sup>2</sup> C clock low time                             | 4.7           |     |      | 1.3                     |     |     | μs   |
| t <sub>sp</sub>        | I <sup>2</sup> C spike time                                 | 0             |     | 50   | 0                       |     | 50  | ns   |
| t <sub>sds</sub>       | I <sup>2</sup> C serial data setup time                     | 250           |     |      | 100                     |     |     | ns   |
| t <sub>sdh</sub>       | I <sup>2</sup> C serial data hold time                      | 0             |     |      | 0                       |     |     | ns   |
| t <sub>icr</sub>       | I <sup>2</sup> C input rise time                            |               |     | 1000 | 20+0.1Cb <sup>(2)</sup> |     | 300 | ns   |
| t <sub>icf</sub>       | I <sup>2</sup> C input fall time                            |               |     | 300  | 20+0.1Cb <sup>(2)</sup> |     | 300 | ns   |
| t <sub>ocf</sub>       | I <sup>2</sup> C output fall time                           |               |     | 300  | 20+0.1Cb <sup>(2)</sup> |     | 300 | ns   |
| t <sub>buf</sub>       | I <sup>2</sup> C bus free time                              | 4.7           |     |      | 1.3                     |     |     | μs   |
| t <sub>sts</sub>       | I <sup>2</sup> C Start setup time                           | 4.7           |     |      | 0.6                     |     |     | μs   |
| t <sub>sth</sub>       | I <sup>2</sup> C Start hold time                            | 4             |     |      | 0.6                     |     |     | μs   |
| t <sub>sp</sub>        | I <sup>2</sup> C Stop setup time                            | 4             |     |      | 0.6                     |     |     | μs   |
| t <sub>vd</sub> (data) | Valid data time (SCL low to SDA valid)                      |               |     | 1    |                         |     | 1   | μs   |
| t <sub>vd</sub> (ack)  | Valid data time of ACK (ACK signal from SCL low to SDA low) |               |     | 1    |                         |     | 1   | μs   |

(1) Not production tested.

(2) C<sub>b</sub> = total capacitance of one bus line in pF

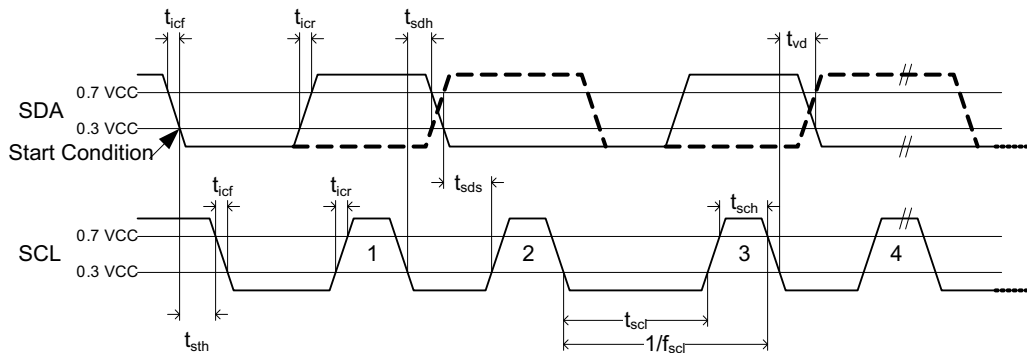

Figure 1. I<sup>2</sup>C Timing Requirements

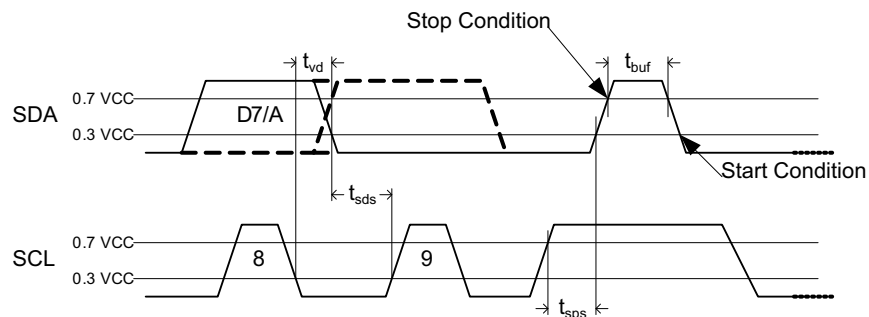

Figure 2. I<sup>2</sup>C Timing Requirements

### 6.7 Typical Characteristics

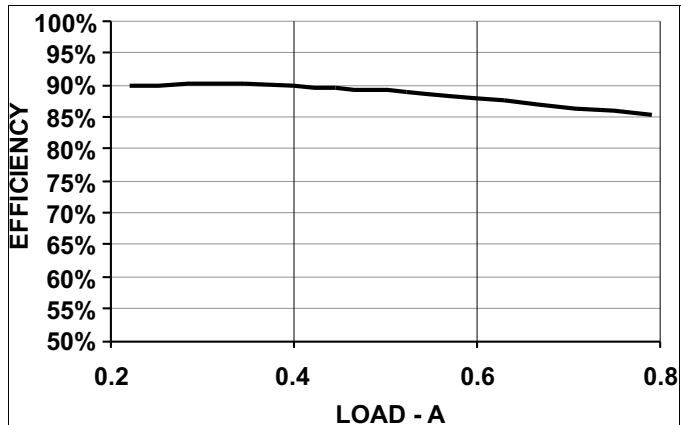

Figure 3. Efficiency vs Load Current  
( $V_{IN} = 5\text{ V}$ ,  $V_{OUT} = 3\text{ V}$ )

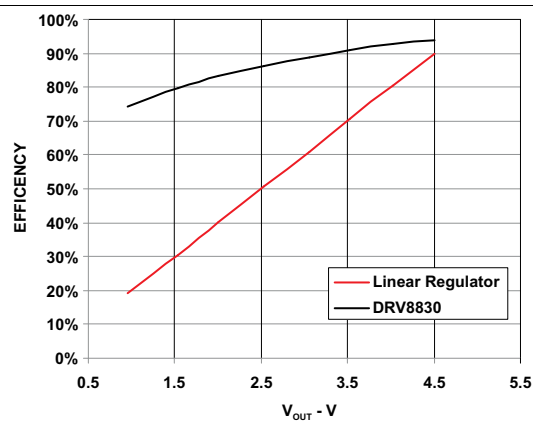

Figure 4. Efficiency vs Output Voltage  
( $V_{IN} = 5\text{ V}$ ,  $I_{OUT} = 500\text{ mA}$ )

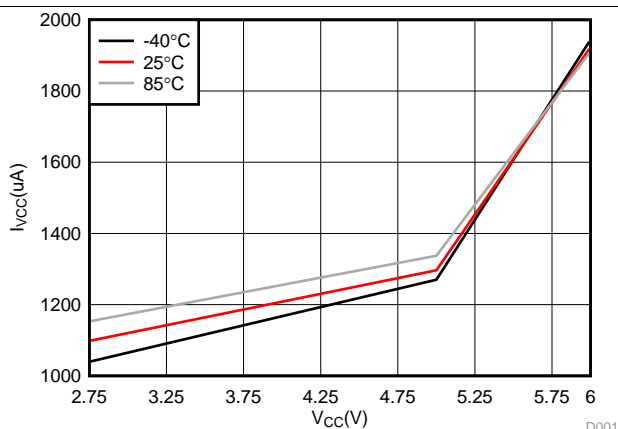

Figure 5.  $I_{VCC}$  vs  $V_{VCC}$

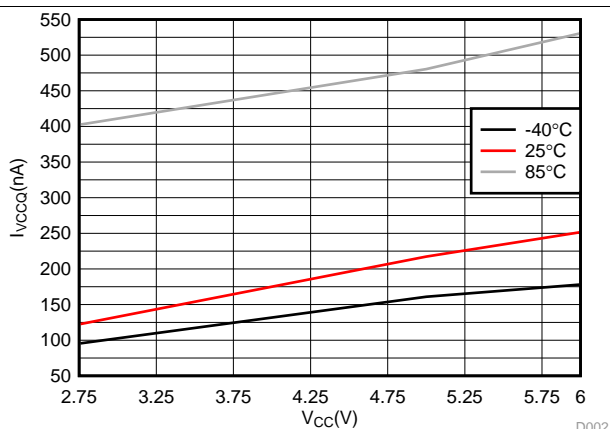

Figure 6.  $I_{VCCQ}$  vs  $V_{VCC}$

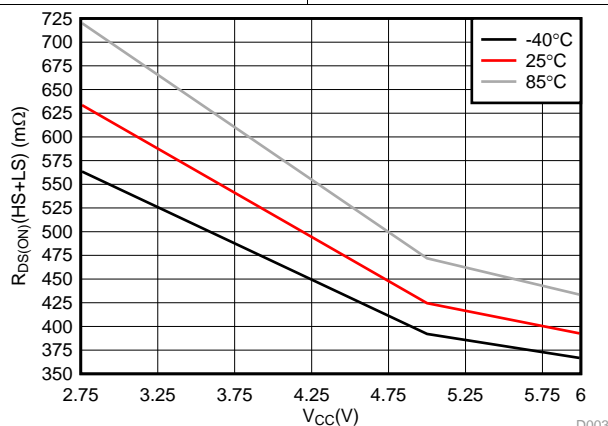

Figure 7.  $R_{DS(on)}$  HS + LS vs  $V_{VCC}$

## 7 Detailed Description

### 7.1 Overview

The DRV8830 is an integrated motor driver solution used for brushed motor control. The device integrates one H-bridge, current regulation circuitry, and a PWM voltage regulation method.

Using the PWM voltage regulation allows the motor to maintain the desired speed as VCC changes. Battery operation is an example of using this feature. When the battery is new or fully charged VCC will be higher than when the battery is old or partially discharged. The speed of the motor will vary based on the voltage of the battery. By setting the desired voltage across the motor at a lower voltage, a fully charged battery will use less power and spin the motor at the same speed as a battery that has been partially discharged.

### 7.2 Functional Block Diagram

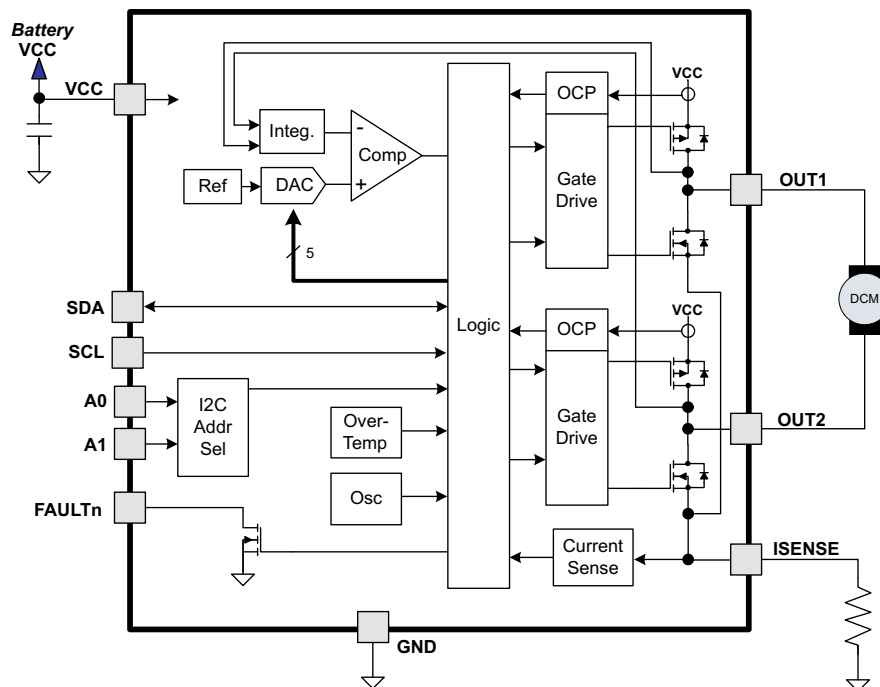

### 7.3 Feature Description

#### 7.3.1 Voltage Regulation

The DRV8830 provides the ability to regulate the voltage applied to the motor winding. This feature allows constant motor speed to be maintained even when operating from a varying supply voltage such as a discharging battery.

The DRV8830 uses a pulse-width modulation (PWM) technique instead of a linear circuit to minimize current consumption and maximize battery life.

The circuit monitors the voltage difference between the output pins and integrates it, to get an average DC voltage value. This voltage is divided by 4 and compared to the output voltage of the VSET DAC, which is set through the serial interface. If the averaged output voltage (divided by 4) is lower than VSET, the duty cycle of the PWM output is increased; if the averaged output voltage (divided by 4) is higher than VSET, the duty cycle is decreased.

During PWM regulation, the H-bridge is enabled to drive current through the motor winding during the PWM on time. This is shown in [Figure 8](#) as case 1. The current flow direction shown indicates the state when IN1 is high and IN2 is low.



### Feature Description (continued)

Note that if the programmed output voltage is greater than the supply voltage, the device will operate at 100% duty cycle and the voltage regulation feature will be disabled. In this mode the device behaves as a conventional H-bridge driver.

During the PWM off time, winding current is recirculated by enabling both of the high-side FETs in the bridge. This is shown in [Figure 8](#).

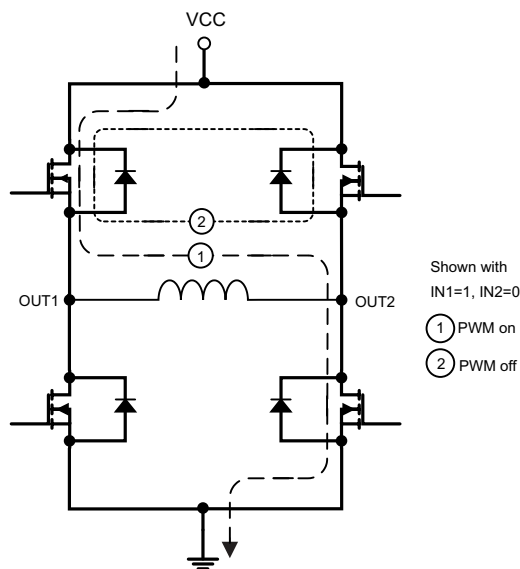

Figure 8. Voltage Regulation

### 7.3.2 Voltage Setting (VSET DAC)

The DRV8830 includes an internal reference voltage that is connected to a DAC. This DAC generates a voltage which is used to set the PWM regulated output voltage as described in [Voltage Regulation](#).

The DAC is controlled by the VSET bits from the serial interface. The commanded output voltage is shown in [Table 1](#).

Table 1. Commanded Output Voltage

| VSET[5..0] | OUTPUT VOLTAGE | VSET[5..0] | OUTPUT VOLTAGE |
|------------|----------------|------------|----------------|
| 0x00h      | Reserved       | 0x20h      | 2.57           |
| 0x01h      | Reserved       | 0x21h      | 2.65           |
| 0x02h      | Reserved       | 0x22h      | 2.73           |
| 0x03h      | Reserved       | 0x23h      | 2.81           |
| 0x04h      | Reserved       | 0x24h      | 2.89           |
| 0x05h      | Reserved       | 0x25h      | 2.97           |
| 0x06h      | 0.48           | 0x26h      | 3.05           |
| 0x07h      | 0.56           | 0x27h      | 3.13           |
| 0x08h      | 0.64           | 0x28h      | 3.21           |
| 0x09h      | 0.72           | 0x29h      | 3.29           |
| 0x0Ah      | 0.80           | 0x2Ah      | 3.37           |
| 0x0Bh      | 0.88           | 0x2Bh      | 3.45           |
| 0x0Ch      | 0.96           | 0x2Ch      | 3.53           |
| 0x0Dh      | 1.04           | 0x2Dh      | 3.61           |
| 0x0Eh      | 1.12           | 0x2Eh      | 3.69           |
| 0x0Fh      | 1.20           | 0x2Fh      | 3.77           |

**Feature Description (continued)**
**Table 1. Commanded Output Voltage (continued)**

| VSET[5..0] | OUTPUT VOLTAGE | VSET[5..0] | OUTPUT VOLTAGE |
|------------|----------------|------------|----------------|
| 0x10h      | 1.29           | 0x30h      | 3.86           |
| 0x11h      | 1.37           | 0x31h      | 3.94           |
| 0x12h      | 1.45           | 0x32h      | 4.02           |
| 0x13h      | 1.53           | 0x33h      | 4.1            |
| 0x14h      | 1.61           | 0x34h      | 4.18           |
| 0x15h      | 1.69           | 0x35h      | 4.26           |
| 0x16h      | 1.77           | 0x36h      | 4.34           |
| 0x17h      | 1.85           | 0x37h      | 4.42           |
| 0x18h      | 1.93           | 0x38h      | 4.5            |
| 0x19h      | 2.01           | 0x39h      | 4.58           |
| 0x1Ah      | 2.09           | 0x3Ah      | 4.66           |
| 0x1Bh      | 2.17           | 0x3Bh      | 4.74           |
| 0x1Ch      | 2.25           | 0x3Ch      | 4.82           |
| 0x1Dh      | 2.33           | 0x3Dh      | 4.9            |
| 0x1Eh      | 2.41           | 0x3Eh      | 4.98           |
| 0x1Fh      | 2.49           | 0x3Fh      | 5.06           |

The voltage can be calculated as  $4 \times V_{REF} \times (VSET + 1) / 64$ , where  $V_{REF}$  is the internal 1.285-V reference.

**7.3.3 Current Limit**

A current limit circuit is provided to protect the system in the event of an overcurrent condition, such as what would be encountered if driving a DC motor at start-up or with an abnormal mechanical load (stall condition).

The motor current is sensed by monitoring the voltage across an external sense resistor. When the voltage exceeds a reference voltage of 200 mV for more than approximately 3  $\mu$ s, the PWM duty cycle is reduced to limit the current through the motor to this value. This current limit allows for starting the motor while controlling the current.

If the current limit condition persists for some time, it is likely that a fault condition has been encountered, such as the motor being run into a stop or a stalled condition. An overcurrent event must persist for approximately 275 ms before the fault is registered. After approximately 275 ms, a fault signaled to the host by driving the FAULTn signal low and setting the FAULT and ILIMIT bits in the serial interface register. Operation of the motor driver will continue.

The current limit fault condition is cleared by setting both IN1 and IN2 to zero to disable the motor current, by putting the device into the shutdown state (IN1 and IN2 both set to 1), by setting the CLEAR bit in the fault register, or by removing and re-applying power to the device.

The resistor used to set the current limit must be less than 1  $\Omega$ . Its value may be calculated as follows:

$$R_{ISENSE} = \frac{200 \text{ mV}}{I_{LIMIT}}$$

where

- $R_{ISENSE}$  is the current sense resistor value.
  - $I_{LIMIT}$  is the desired current limit (in mA).
- (1)

If the current limit feature is not needed, the ISENSE pin may be directly connected to ground.

**7.3.4 Protection Circuits**

The DRV8830 is fully protected against undervoltage, overcurrent and overtemperature events. A FAULTn pin is available to signal a fault condition to the system, as well as a FAULT register in the serial interface that allows determination of the fault source.

### 7.3.4.1 Overcurrent Protection (OCP)

An analog current limit circuit on each FET limits the current through the FET by removing the gate drive. If this analog current limit persists for longer than the OCP time, all FETs in the H-bridge will be disabled, the FAULTn signal will be driven low, and the FAULT and OCP bits in the FAULT register will be set. The device will remain disabled until the CLEAR bit in the FAULT register is written to 1, or VCC is removed and re-applied.

Overcurrent conditions are sensed independently on both high and low side devices. A short to ground, supply, or across the motor winding will all result in an overcurrent shutdown. Note that OCP is independent of the current limit function, which is typically set to engage at a lower current level; the OCP function is intended to prevent damage to the device under abnormal (for example, short circuit) conditions.

### 7.3.4.2 Thermal Shutdown (TSD)

If the die temperature exceeds safe limits, all FETs in the H-bridge will be disabled, the FAULTn signal will be driven low, and the FAULT and OTS bits in the serial interface register will be set. Once the die temperature has fallen to a safe level operation will automatically resume.

### 7.3.4.3 Undervoltage Lockout (UVLO)

If at any time the voltage on the VCC pins falls below the undervoltage lockout threshold voltage, all FETs in the H-bridge will be disabled, the FAULTn signal will be driven low, and the FAULT and UVLO bits in the FAULT register will be set. Operation will resume when VCC rises above the UVLO threshold.

**Table 2. Device Protection**

| FAULT                   | CONDITION           | ERROR REPORT | H-BRIDGE | INTERNAL CIRCUITS | RECOVERY                  |
|-------------------------|---------------------|--------------|----------|-------------------|---------------------------|
| VCC undervoltage (UVLO) | $VCC < V_{UVLO}$    | FAULTn       | Disabled | Disabled          | $VCC > V_{UVLO}$          |
| Overcurrent (OCP)       | $I_{OUT} > I_{OCP}$ | FAULT n      | Disabled | Operating         | Power cycle VCC           |
| Thermal shutdown (TSD)  | $T_J > T_{TSD}$     | FAULTn       | Disabled | Operating         | $T_J > T_{TSD} - T_{HYS}$ |

## 7.4 Device Functional Modes

The DRV8830 is active when either IN1 or IN2 are set to a logic high. Sleep mode is entered when both IN1 and IN2 are set to a logic low. When in sleep mode, the H-bridge FETs are disabled (Hi-Z).

**Table 3. Modes of Operation**

| FAULT             | CONDITION               | H-BRIDGE  | INTERNAL CIRCUITS           |
|-------------------|-------------------------|-----------|-----------------------------|
| Operating         | IN1 or IN2 high         | Operating | Operating                   |
| Sleep mode        | IN1 or IN2 low          | Disabled  | Diabed                      |
| Fault encountered | Any fault condition met | Disabled  | See <a href="#">Table 2</a> |

### 7.4.1 Bridge Control

The IN1 and IN2 control bits in the serial interface register enable the H-bridge outputs. [Table 4](#) shows the logic:

**Table 4. H-Bridge Logic**

| IN1 | IN2 | OUT1 | OUT2 | FUNCTION        |
|-----|-----|------|------|-----------------|
| 0   | 0   | Z    | Z    | Standby / coast |
| 0   | 1   | L    | H    | Reverse         |
| 1   | 0   | H    | L    | Forward         |
| 1   | 1   | H    | H    | Brake           |

When both bits are zero, the output drivers are disabled and the device is placed into a low-power shutdown state. The current limit fault condition (if present) is also cleared.

At initial power up, the device will enter the low-power shutdown state. Note that when transitioning from either brake or standby mode to forward or reverse, the voltage control PWM starts at zero duty cycle. The duty cycle slowly ramps up to the commanded voltage. This can take up to 12 ms to go from standby to 100% duty cycle.

## 7.5 Programming

### 7.5.1 I<sup>2</sup>C-Compatible Serial Interface

The I<sup>2</sup>C interface allows control and monitoring of the DRV8830 by a microcontroller. I<sup>2</sup>C is a two-wire serial interface developed by Philips Semiconductor (see I<sup>2</sup>C – Bus Specification, Version 2.1, January 2000). The bus consists of a data line (SDA) and a clock line (SCL) with off-chip pull-up resistors. When the bus is idle, both SDA and SCL lines are pulled high.

A master device, usually a microcontroller or a digital signal processor, controls the bus. The master is responsible for generating the SCL signal and device addresses. The master also generates specific conditions that indicate the START and STOP of data transfer.

A slave device receives and/or transmits data on the bus under control of the master device. This device operates only as a slave device.

I<sup>2</sup>C communication is initiated by a master sending a start condition, a high-to-low transition on the SDA I/O while SCL is held high. After the start condition, the device address byte is sent, most-significant bit (MSB) first, including the data direction bit (R/W). After receiving a valid address byte, this device responds with an acknowledge, a low on the SDA I/O during the high of the acknowledge-related clock pulse.

The lower three bits of the device address are input from pins A0 - A1, which can be tied to VCC (logic high), GND (logic low), or left open. These three address bits are latched into the device at power up, so cannot be changed dynamically.

The upper address bits of the device address are fixed at 0xC0h, so the device address is as follows:

**Table 5. Device Addresses**

| A1 PIN | A0 PIN | A3..A0 BITS<br>(as below) | ADDRESS (WRITE) | ADDRESS (READ) |
|--------|--------|---------------------------|-----------------|----------------|
| 0      | 0      | 0000                      | 0xC0h           | 0xC1h          |
| 0      | open   | 0001                      | 0xC2h           | 0xC3h          |
| 0      | 1      | 0010                      | 0xC4h           | 0xC5h          |
| open   | 0      | 0011                      | 0xC6h           | 0xC7h          |
| open   | open   | 0100                      | 0xC8h           | 0xC9h          |
| open   | 1      | 0101                      | 0xCAh           | 0xCBh          |
| 1      | 0      | 0110                      | 0xCCh           | 0xCDh          |
| 1      | open   | 0111                      | 0xCEh           | 0xCFh          |
| 1      | 1      | 1000                      | 0xD0h           | 0xD1h          |

The DRV8830 does not respond to the general call address.

A data byte follows the address acknowledge. If the R/W bit is low, the data is written from the master. If the R/W bit is high, the data from this device are the values read from the register previously selected by a write to the subaddress register. The data byte is followed by an acknowledge sent from this device. Data is output only if complete bytes are received and acknowledged. A stop condition, which is a low-to-high transition on the SDA I/O while the SCL input is high, is sent by the master to terminate the transfer.

A master bus device must wait at least 60  $\mu$ s after power is applied to VCC to generate a START condition.

I<sup>2</sup>C transactions are shown in the timing diagrams [Figure 9](#) and [Figure 10](#):

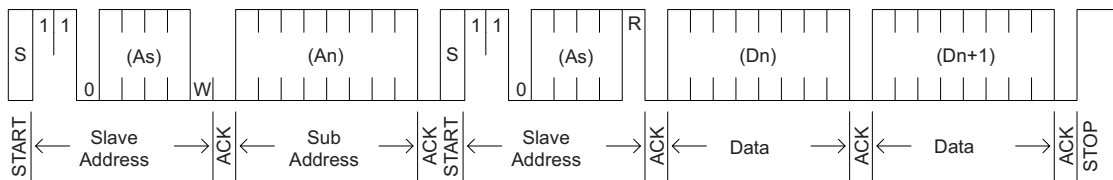

**Figure 9. I<sup>2</sup>C Read Mode**

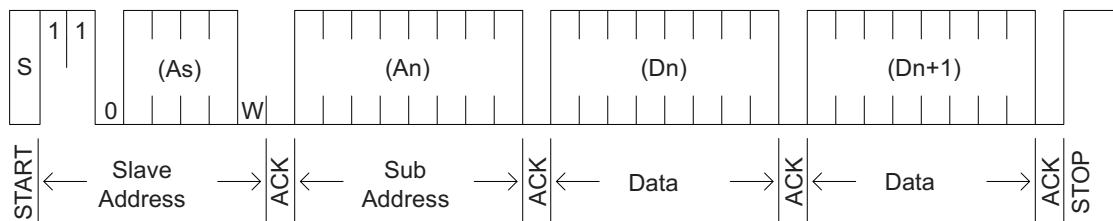

**Figure 10. I<sup>2</sup>C Write Mode**

**7.6 Register Maps**

**7.6.1 I<sup>2</sup>C Register Map**

**Table 6. I<sup>2</sup>C Register Map**

| REGISTER | SUB ADDRESS (HEX) | REGISTER NAME | DEFAULT VALUE | DESCRIPTION                                     |
|----------|-------------------|---------------|---------------|---|
| 0        | 0x00              | CONTROL       | 0x00h         | Sets state of outputs and output voltage        |
| 1        | 0x01              | FAULT         | 0x00h         | Allows reading and clearing of fault conditions |

**7.6.1.1 REGISTER 0 – CONTROL**

The CONTROL register is used to set the state of the outputs as well as the DAC setting for the output voltage. The register is defined as follows:

**Table 7. Register 0 – Control**

| D7 - D2    | D1  | D0  |
|------------|-----|-----|
| VSET[5..0] | IN2 | IN1 |

- VSET[5..0]: Sets DAC output voltage. Refer to Voltage Setting above.
- IN2: Along with IN1, sets state of outputs. Refer to Bridge Control above.
- IN1: Along with IN2, sets state of outputs. Refer to Bridge Control above.

**7.6.1.2 REGISTER 1 – FAULT**

The FAULT register is used to read the source of a fault condition, and to clear the status bits that indicated the fault. The register is defined as follows:

**Table 8. Register 1 – Fault**

| D7    | D6 - D5 | D4     | D3  | D2   | D1  | D0    |
|-------|---------|--------|-----|------|-----|-------|
| CLEAR | Unused  | ILIMIT | OTS | UVLO | OCP | FAULT |

**DRV8830**

SLVSAB2G – MAY 2010 – REVISED DECEMBER 2015

[www.ti.com](http://www.ti.com)

---

|         |   |
|---------|---|
| CLEAR:  | When written to 1, clears the fault status bits                                   |
| ILIMIT: | If set, indicates the fault was caused by an extended current limit event         |
| OTS:    | If set, indicates that the fault was caused by an overtemperature (OTS) condition |
| UVLO:   | If set, indicates the fault was caused by an undervoltage lockout                 |
| OCP:    | If set, indicates the fault was caused by an overcurrent (OCP) event              |
| FAULT:  | Set if any fault condition exists   |

## 8 Application and Implementation

### NOTE

Information in the following applications sections is not part of the TI component specification, and TI does not warrant its accuracy or completeness. TI's customers are responsible for determining suitability of components for their purposes. Customers should validate and test their design implementation to confirm system functionality.

### 8.1 Application Information

The DRV8830 is used in brushed DC applications to provide a constant motor speed over varying voltages. The following design procedure can be used to configure the DRV8830 for a system with a VCC variance of 4 to 6 V.

### 8.2 Typical Application

Figure 11 is a common application of the DRV8830.

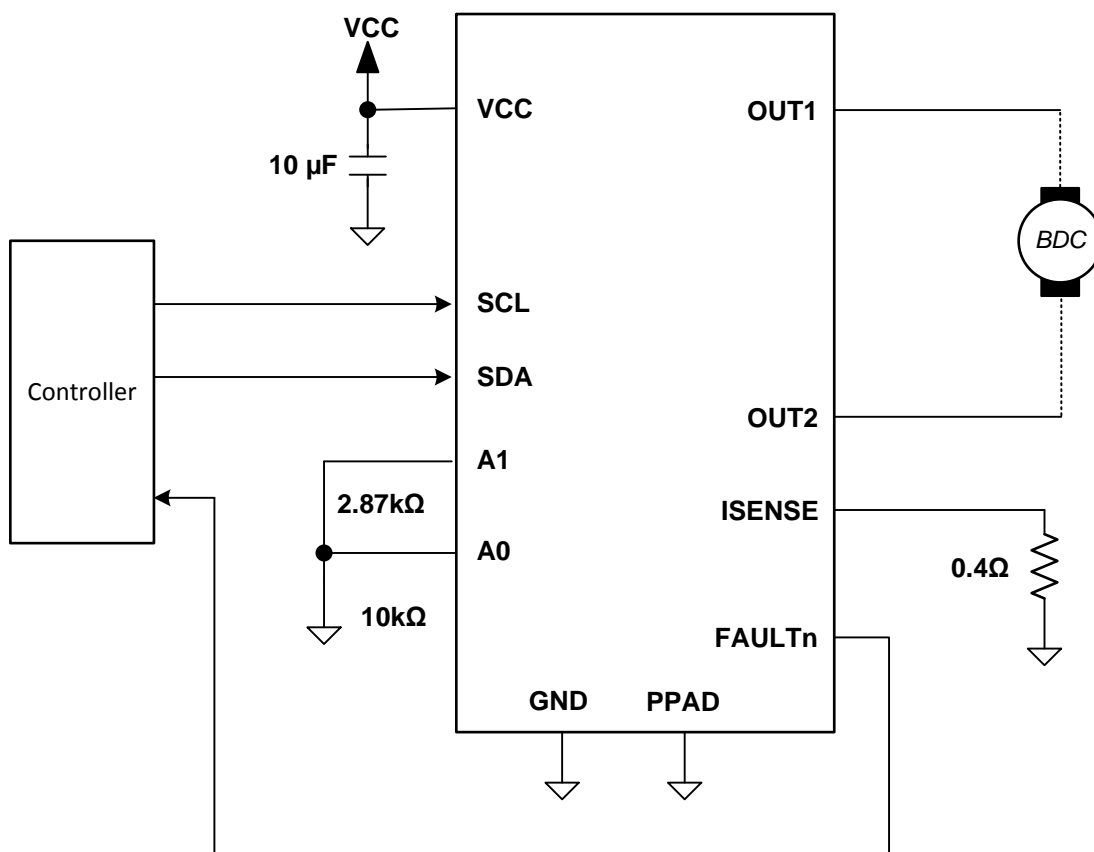

Figure 11. Motor Control Circuitry

## Typical Application (continued)

### 8.2.1 Design Requirements

Table 9 lists the design parameters of the DRV8830.

**Table 9. Design Parameters**

| DESIGN PARAMETER         | REFERENCE          | EXAMPLE VALUE |
|--------------------------|--------------------|---------------|
| Motor voltage            | V <sub>CC</sub>    | 5 V           |
| Motor RMS current        | I <sub>RMS</sub>   | 0.3 A         |
| Motor start-up           | I <sub>START</sub> | 1.3 A         |
| Motor current trip point | I <sub>LIMIT</sub> | 0.9 A         |

### 8.2.2 Detailed Design Procedure

#### 8.2.2.1 Motor Voltage

The motor voltage to use will depend on the ratings of the motor selected and the desired RPM. A higher voltage spins a brushed DC motor faster with the same PWM duty cycle applied to the power FETs. A higher voltage also increases the rate of current change through the inductive motor windings.

For the DRV8830, TI recommends to set a motor voltage at the lowest system VCC. This will maintain a constant RPM across varying VCC conditions.

For example if the VCC voltage can vary from 4.5V to 5.5V, setting the VSET voltage to 1.125 V will compensate for power supply variation. The DRV8830 will set the motor voltage at 4.5 V, even if VCC is 5.5 V.

#### 8.2.2.2 Motor Current Trip Point

When the voltage on pin ISENSE exceeds VILIM (0.2 V), overcurrent is detected. The RSENSE resistor should be sized to set the desired ILIMIT level.

$$R_{\text{ISENSE}} = 0.2 \text{ V} / I_{\text{LIMIT}} \quad (2)$$

To set I<sub>LIMIT</sub> to 0.5 A, R<sub>ISENSE</sub> = 0.2 V / 0.9 A = 0.22 Ω.

To prevent false trips, I<sub>LIMIT</sub> must be higher than regular operating current. Motor current during start-up is typically much higher than steady-state spinning, because the initial load torque is higher, and the absence of back-EMF causes a higher voltage and extra current across the motor windings.

It can be beneficial to limit start-up current by using series inductors on the DRV8830 output, as that allows I<sub>LIMIT</sub> to be lower, and it may decrease the system's required bulk capacitance. Start-up current can also be limited by ramping the forward drive duty cycle.

#### 8.2.2.3 Sense Resistor Selection

For optimal performance, it is important for the sense resistor to be:

- Surface-mount
- Low inductance
- Rated for high enough power
- Placed closely to the motor driver

The power dissipated by the sense resistor equals I<sub>RMS</sub><sup>2</sup> × R. For example, if peak motor current is 1 A, RMS motor current is 0.7 A, and a 0.4-Ω sense resistor is used, the resistor will dissipate 0.7 A<sup>2</sup> × 0.4 Ω = 0.2 W. The power quickly increases with higher current levels.

Resistors typically have a rated power within some ambient temperature range, along with a de-rated power curve for high ambient temperatures. When a PCB is shared with other components generating heat, margin should be added. It is always best to measure the actual sense resistor temperature in a final system, along with the power MOSFETs, as those are often the hottest components.



Because power resistors are larger and more expensive than standard resistors, it is common practice to use multiple standard resistors in parallel, between the sense node and ground. This distributes the current and heat dissipation.

### 8.2.2.4 Low Power Operation

Under normal operation, using sleep mode to minimize supply current should be sufficient.

If desired, power can be removed to the DRV8830 to further decrease supply current. TI recommends to remove power to the FAULTn pullup resistor when removing power to the DRV8830. Removing power from the FAULTn pullup resistor will eliminate a current path from the FAULTn pin through an ESD protection diode to VCC. TI recommends to set both IN1 and IN2 as a logic low when power is removed.

An undervoltage event may cause the address to be re-evaluated. If this occurs, the I<sup>2</sup>C interface may stop working until power is cycled.

### 8.2.3 Application Curves

The following scope captures show how the output duty cycle changes to as VCC increases. This allows the motor to spin at a constant speed as VCC changes. At VCC = 3.9 V, the output duty cycle is 100% on. As the VCC voltage increases to greater than 4 V, the output duty cycle begins to decrease. The output duty cycle is shown at VCC = 4.5 V, VCC = 5 V and VCC = 5.5 V.

- Channel 1 – OUT1: IN1 – Logic Low
- Channel 2 – OUT2: IN2 – Logic High
- Channel 4 – Motor current: VSET – 1 V
- Motor used: NMB Technologies Corporation, PPN7PA12C1

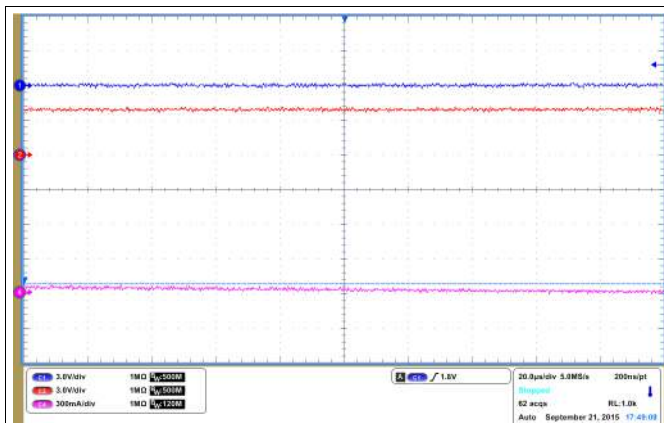

Figure 12. Output Pulse Width Modulating at VCC = 3.9 V

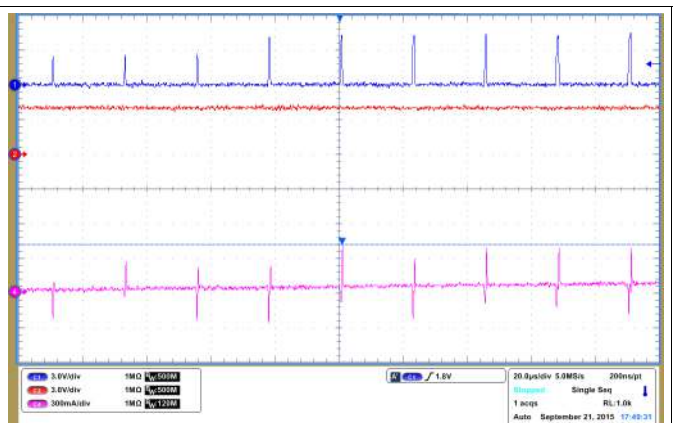

Figure 13. Output Pulse Width Modulating at VCC = 4 V

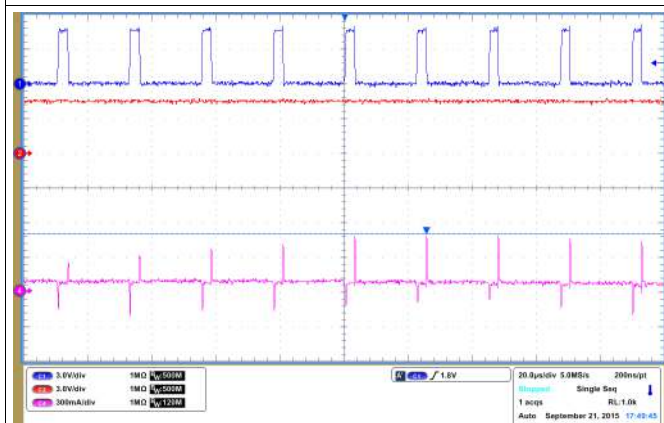

Figure 14. Output Pulse Width Modulating at VCC = 4.5 V

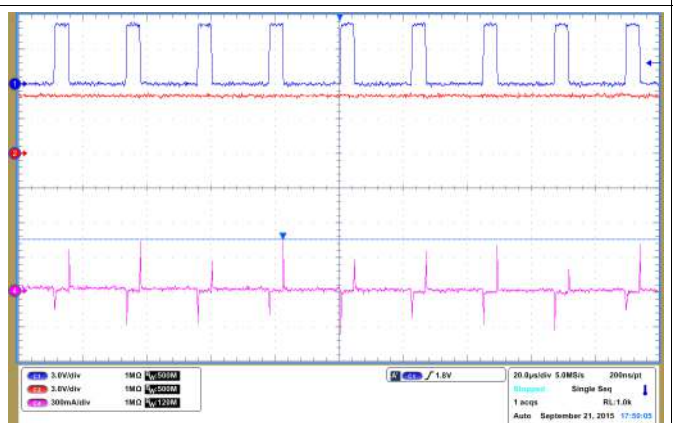
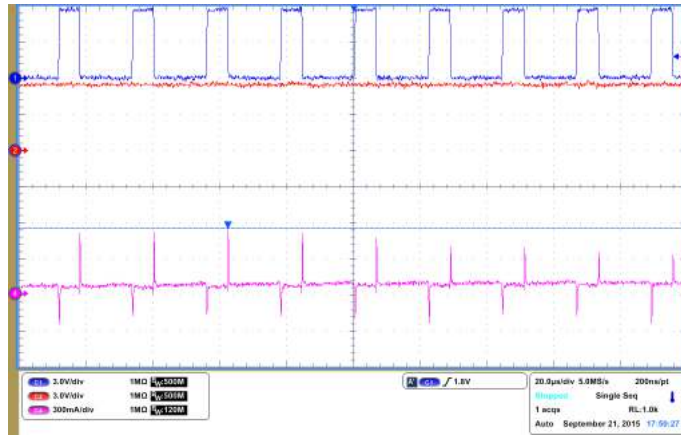

Figure 15. Output Pulse Width Modulating at VCC = 5 V



**Figure 16. Output Pulse Width Modulating at VCC = 5.5 V**

## 9 Power Supply Recommendations

### 9.1 Power Supervisor

The DRV8830 is capable of entering a low-power sleep mode by bringing both of the INx control inputs logic low. The outputs will be disabled Hi-Z.

To exit the sleep mode, bring either or both of the INx inputs logic high. This will enable the H-bridges. When exiting the sleep mode, the FAULTn pin will pulse low.

### 9.2 Bulk Capacitance

Having appropriate local bulk capacitance is an important factor in motor drive system design. It is generally beneficial to have more bulk capacitance, while the disadvantages are increased cost and physical size.

The amount of local capacitance needed depends on a variety of factors, including:

- The highest current required by the motor system.
- The power supply's capacitance and ability to source current.
- The amount of parasitic inductance between the power supply and motor system.
- The acceptable voltage ripple.
- The type of motor used (Brushed DC, Brushless DC, Stepper).
- The motor braking method.

The inductance between the power supply and motor drive system will limit the rate current can change from the power supply. If the local bulk capacitance is too small, the system will respond to excessive current demands or dumps from the motor with a change in voltage. When adequate bulk capacitance is used, the motor voltage remains stable and high current can be quickly supplied.

The data sheet generally provides a recommended value, but system-level testing is required to determine the appropriate sized bulk capacitor.

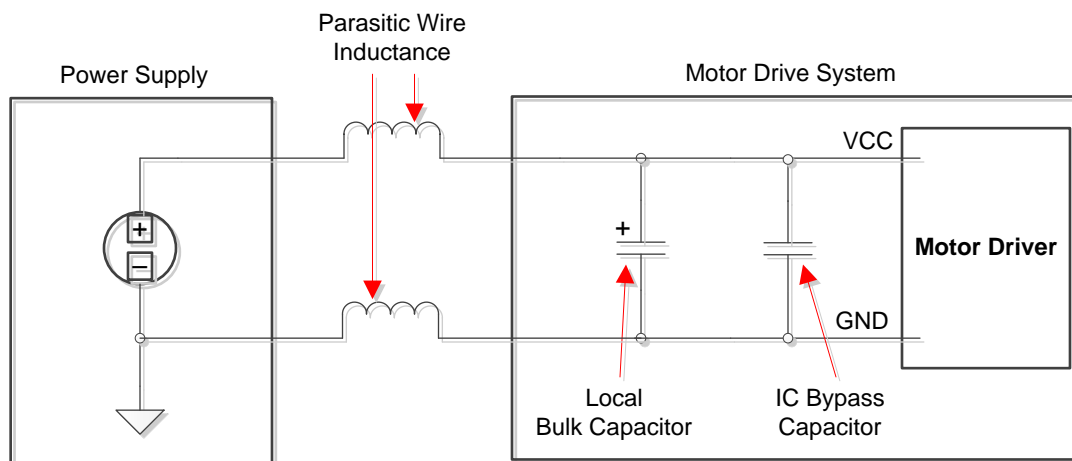

Figure 17. Example Setup of Motor Drive System with External Power Supply

The voltage rating for bulk capacitors should be higher than the operating voltage, to provide margin for cases when the motor transfers energy to the supply.

## 10 Layout

### 10.1 Layout Guidelines

The VCC pin should be bypassed to GND using low-ESR ceramic bypass capacitors with a recommended value of 0.1- $\mu\text{F}$  rated for VCC. This capacitor should be placed as close to the VCC pin as possible with a thick trace or ground plane connection to the device GND pin.

The VCC pin must be bypassed to ground using an appropriate bulk capacitor. This component may be an electrolytic and should be located close to the DRV8830.

### 10.2 Layout Example

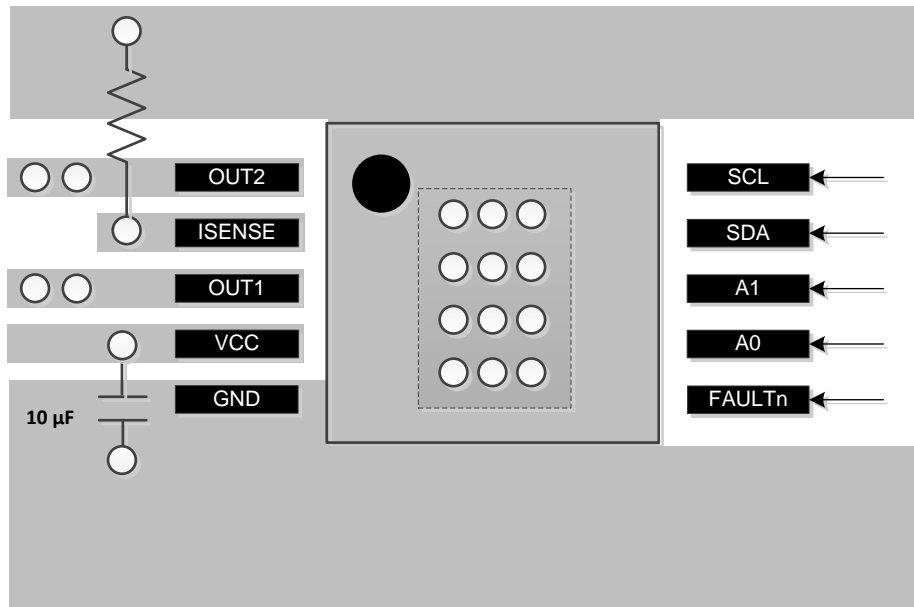

**Figure 18. Layout Recommendation**

### 10.3 Thermal Considerations

The DRV8830 has thermal shutdown (TSD) as described in [Thermal Shutdown \(TSD\)](#). If the die temperature exceeds approximately 160°C, the device will be disabled until the temperature drops to a safe level. Any tendency of the device to enter TSD is an indication of either excessive power dissipation, insufficient heatsinking, or too high an ambient temperature.

#### 10.3.1 Power Dissipation

Power dissipation in the DRV8830 is dominated by the power dissipated in the output FET resistance, or  $R_{DS(ON)}$ . Average power dissipation when running a stepper motor can be roughly estimated by [Equation 3](#).

$$P_{TOT} = 2 \cdot R_{DS(ON)} \cdot (I_{OUT(RMS)})^2 \quad (3)$$

where  $P_{TOT}$  is the total power dissipation,  $R_{DS(ON)}$  is the resistance of each FET, and  $I_{OUT(RMS)}$  is the RMS output current being applied to each winding.  $I_{OUT(RMS)}$  is equal to the approximately 0.7x the full-scale output current setting. The factor of 2 comes from the fact that at any instant two FETs are conducting winding current for each winding (one high-side and one low-side).

The maximum amount of power that can be dissipated in the device is dependent on ambient temperature and heatsinking.

Note that  $R_{DS(ON)}$  increases with temperature, so as the device heats, the power dissipation increases. This must be taken into consideration when sizing the heatsink.

## 11 Device and Documentation Support

### 11.1 Documentation Support

#### 11.1.1 Related Documentation

For related documentation, see the following:

- [PowerPAD™ Thermally Enhanced Package, SLMA002](#)
- [PowerPAD™ Made Easy, SLMA004](#)

### 11.2 Community Resources

The following links connect to TI community resources. Linked contents are provided "AS IS" by the respective contributors. They do not constitute TI specifications and do not necessarily reflect TI's views; see TI's [Terms of Use](#).

**TI E2E™ Online Community** *TI's Engineer-to-Engineer (E2E) Community*. Created to foster collaboration among engineers. At [e2e.ti.com](#), you can ask questions, share knowledge, explore ideas and help solve problems with fellow engineers.

**Design Support** *TI's Design Support* Quickly find helpful E2E forums along with design support tools and contact information for technical support.

### 11.3 Trademarks

PowerPAD, E2E are trademarks of Texas Instruments. All other trademarks are the property of their respective owners.

### 11.4 Electrostatic Discharge Caution



These devices have limited built-in ESD protection. The leads should be shorted together or the device placed in conductive foam during storage or handling to prevent electrostatic damage to the MOS gates.

### 11.5 Glossary

[SLYZ022](#) — *TI Glossary*.

This glossary lists and explains terms, acronyms, and definitions.

## 12 Mechanical, Packaging, and Orderable Information

The following pages include mechanical, packaging, and orderable information. This information is the most current data available for the designated devices. This data is subject to change without notice and revision of this document. For browser-based versions of this data sheet, refer to the left-hand navigation.

**PACKAGING INFORMATION**

| Orderable Device | Status<br>(1) | Package Type | Package Drawing | Pins | Package Qty | Eco Plan<br>(2) | Lead finish/<br>Ball material<br>(6) | MSL Peak Temp<br>(3) | Op Temp (°C) | Device Marking<br>(4/5) | Samples                 |
|------------------|---------------|--------------|-----------------|------|-------------|-----------------|--------------------------------------|----------------------|--------------|-------------------------|-------------------------|
| DRV8830DGQ       | ACTIVE        | HVSSOP       | DGQ             | 10   | 80          | RoHS & Green    | NIPDAUAG                             | Level-2-260C-1 YEAR  | -40 to 85    | 8830                    | <a href="#">Samples</a> |
| DRV8830DGQR      | ACTIVE        | HVSSOP       | DGQ             | 10   | 2500        | RoHS & Green    | NIPDAUAG                             | Level-2-260C-1 YEAR  | -40 to 85    | 8830                    | <a href="#">Samples</a> |
| DRV8830DRCR      | ACTIVE        | VSON         | DRC             | 10   | 3000        | RoHS & Green    | NIPDAU                               | Level-1-260C-UNLIM   | -40 to 85    | 8830                    | <a href="#">Samples</a> |
| DRV8830DRCT      | ACTIVE        | VSON         | DRC             | 10   | 250         | RoHS & Green    | NIPDAU                               | Level-1-260C-UNLIM   | -40 to 85    | 8830                    | <a href="#">Samples</a> |

(1) The marketing status values are defined as follows:

**ACTIVE:** Product device recommended for new designs.

**LIFEBUY:** TI has announced that the device will be discontinued, and a lifetime-buy period is in effect.

**NRND:** Not recommended for new designs. Device is in production to support existing customers, but TI does not recommend using this part in a new design.

**PREVIEW:** Device has been announced but is not in production. Samples may or may not be available.

**OBSELETE:** TI has discontinued the production of the device.

(2) **RoHS:** TI defines "RoHS" to mean semiconductor products that are compliant with the current EU RoHS requirements for all 10 RoHS substances, including the requirement that RoHS substance do not exceed 0.1% by weight in homogeneous materials. Where designed to be soldered at high temperatures, "RoHS" products are suitable for use in specified lead-free processes. TI may reference these types of products as "Pb-Free".

**RoHS Exempt:** TI defines "RoHS Exempt" to mean products that contain lead but are compliant with EU RoHS pursuant to a specific EU RoHS exemption.

**Green:** TI defines "Green" to mean the content of Chlorine (Cl) and Bromine (Br) based flame retardants meet JS709B low halogen requirements of <=1000ppm threshold. Antimony trioxide based flame retardants must also meet the <=1000ppm threshold requirement.

(3) MSL, Peak Temp. - The Moisture Sensitivity Level rating according to the JEDEC industry standard classifications, and peak solder temperature.

(4) There may be additional marking, which relates to the logo, the lot trace code information, or the environmental category on the device.

(5) Multiple Device Markings will be inside parentheses. Only one Device Marking contained in parentheses and separated by a "-" will appear on a device. If a line is indented then it is a continuation of the previous line and the two combined represent the entire Device Marking for that device.

(6) Lead finish/Ball material - Orderable Devices may have multiple material finish options. Finish options are separated by a vertical ruled line. Lead finish/Ball material values may wrap to two lines if the finish value exceeds the maximum column width.

**Important Information and Disclaimer:**The information provided on this page represents TI's knowledge and belief as of the date that it is provided. TI bases its knowledge and belief on information provided by third parties, and makes no representation or warranty as to the accuracy of such information. Efforts are underway to better integrate information from third parties. TI has taken and

continues to take reasonable steps to provide representative and accurate information but may not have conducted destructive testing or chemical analysis on incoming materials and chemicals. TI and TI suppliers consider certain information to be proprietary, and thus CAS numbers and other limited information may not be available for release.

In no event shall TI's liability arising out of such information exceed the total purchase price of the TI part(s) at issue in this document sold by TI to Customer on an annual basis.

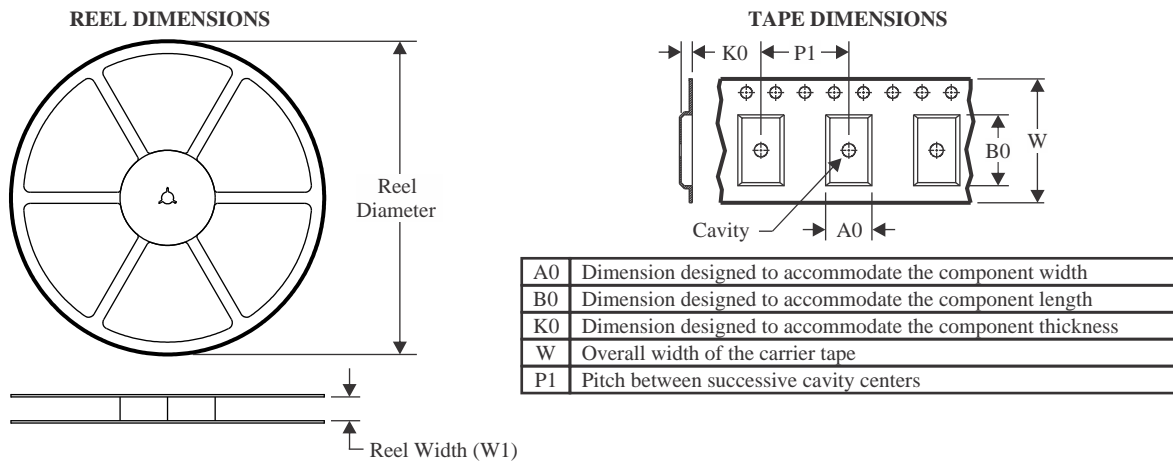
**TAPE AND REEL INFORMATION**

**QUADRANT ASSIGNMENTS FOR PIN 1 ORIENTATION IN TAPE**

\*All dimensions are nominal

| Device      | Package Type | Package Drawing | Pins | SPQ  | Reel Diameter (mm) | Reel Width W1 (mm) | A0 (mm) | B0 (mm) | K0 (mm) | P1 (mm) | W (mm) | Pin1 Quadrant |
|-------------|--------------|-----------------|------|------|--------------------|--------------------|---------|---------|---------|---------|--------|---------------|
| DRV8830DGQR | HVSSOP       | DGQ             | 10   | 2500 | 330.0              | 12.4               | 5.3     | 3.4     | 1.4     | 8.0     | 12.0   | Q1            |
| DRV8830DRCR | VSON         | DRC             | 10   | 3000 | 330.0              | 12.4               | 3.3     | 3.3     | 1.1     | 8.0     | 12.0   | Q2            |
| DRV8830DRCT | VSON         | DRC             | 10   | 250  | 180.0              | 12.4               | 3.3     | 3.3     | 1.1     | 8.0     | 12.0   | Q2            |



**TAPE AND REEL BOX DIMENSIONS**

\*All dimensions are nominal

| Device      | Package Type | Package Drawing | Pins | SPQ  | Length (mm) | Width (mm) | Height (mm) |
|-------------|--------------|-----------------|------|------|-------------|------------|-------------|
| DRV8830DGQR | HVSSOP       | DGQ             | 10   | 2500 | 356.0       | 356.0      | 35.0        |
| DRV8830DRCR | VSON         | DRC             | 10   | 3000 | 335.0       | 335.0      | 25.0        |
| DRV8830DRCT | VSON         | DRC             | 10   | 250  | 182.0       | 182.0      | 20.0        |

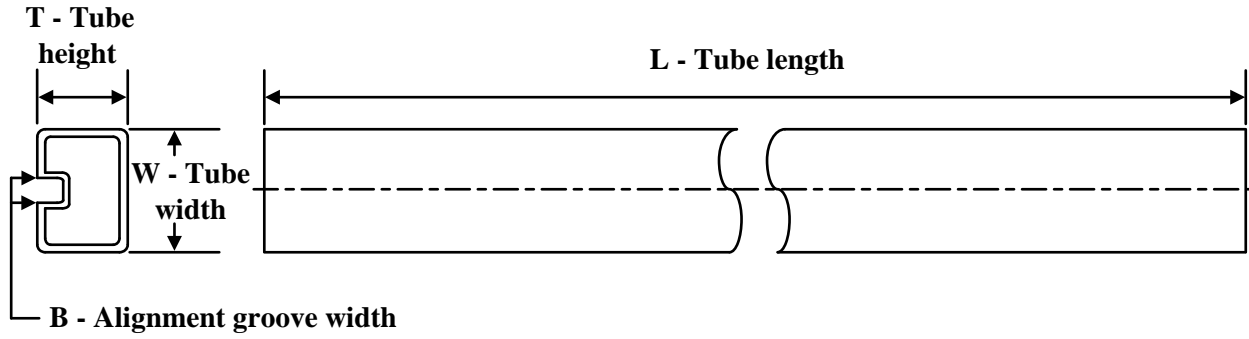
**TUBE**

\*All dimensions are nominal

| Device     | Package Name | Package Type | Pins | SPQ | L (mm) | W (mm) | T (μm) | B (mm) |
|------------|--------------|--------------|------|-----|--------|--------|--------|--------|
| DRV8830DGQ | DGQ          | HVSSOP       | 10   | 80  | 330.2  | 6.6    | 3005   | 1.88   |

## GENERIC PACKAGE VIEW

**DGQ 10**

**PowerPAD™ HVSSOP - 1.1 mm max height**

3 x 3, 0.5 mm pitch

PLASTIC SMALL OUTLINE

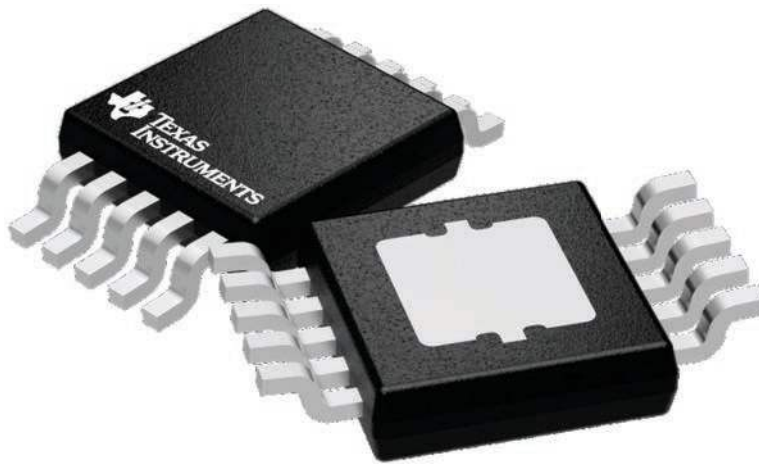

Images above are just a representation of the package family, actual package may vary.  
Refer to the product data sheet for package details.

4224775/A

# DGQ0010E



# PACKAGE OUTLINE

PowerPAD™ - 1.1 mm max height

PLASTIC SMALL OUTLINE

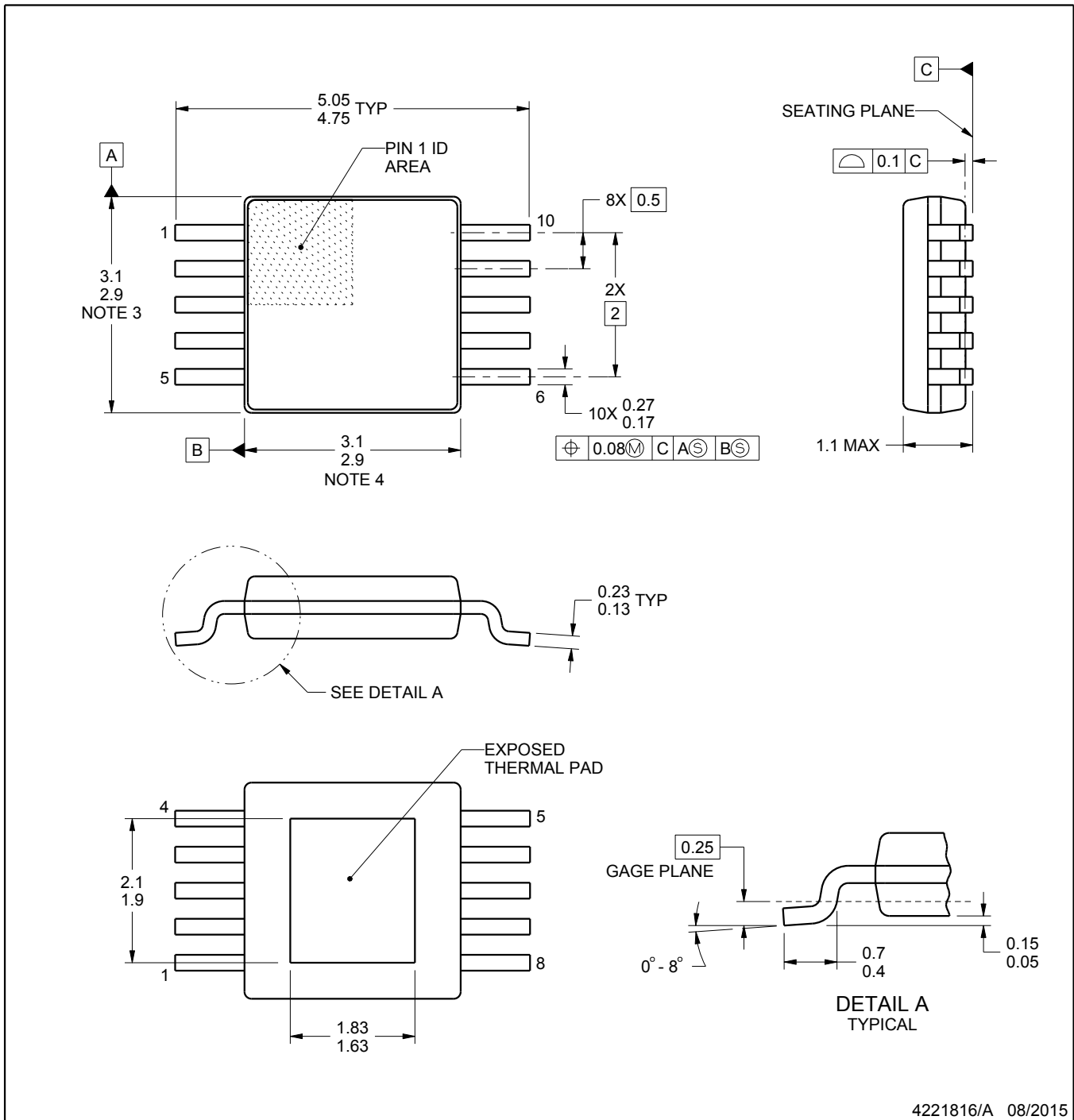

4221816/A 08/2015

PowerPAD is a trademark of Texas Instruments.

**NOTES:**

1. All linear dimensions are in millimeters. Any dimensions in parenthesis are for reference only. Dimensioning and tolerancing per ASME Y14.5M.
2. This drawing is subject to change without notice.
3. This dimension does not include mold flash, protrusions, or gate burrs. Mold flash, protrusions, or gate burrs shall not exceed 0.15 mm per side.
4. This dimension does not include interlead flash. Interlead flash shall not exceed 0.25 mm per side.
5. Reference JEDEC registration MO-187, variation BA-T.

# EXAMPLE BOARD LAYOUT

DGQ0010E

PowerPAD™ - 1.1 mm max height

PLASTIC SMALL OUTLINE

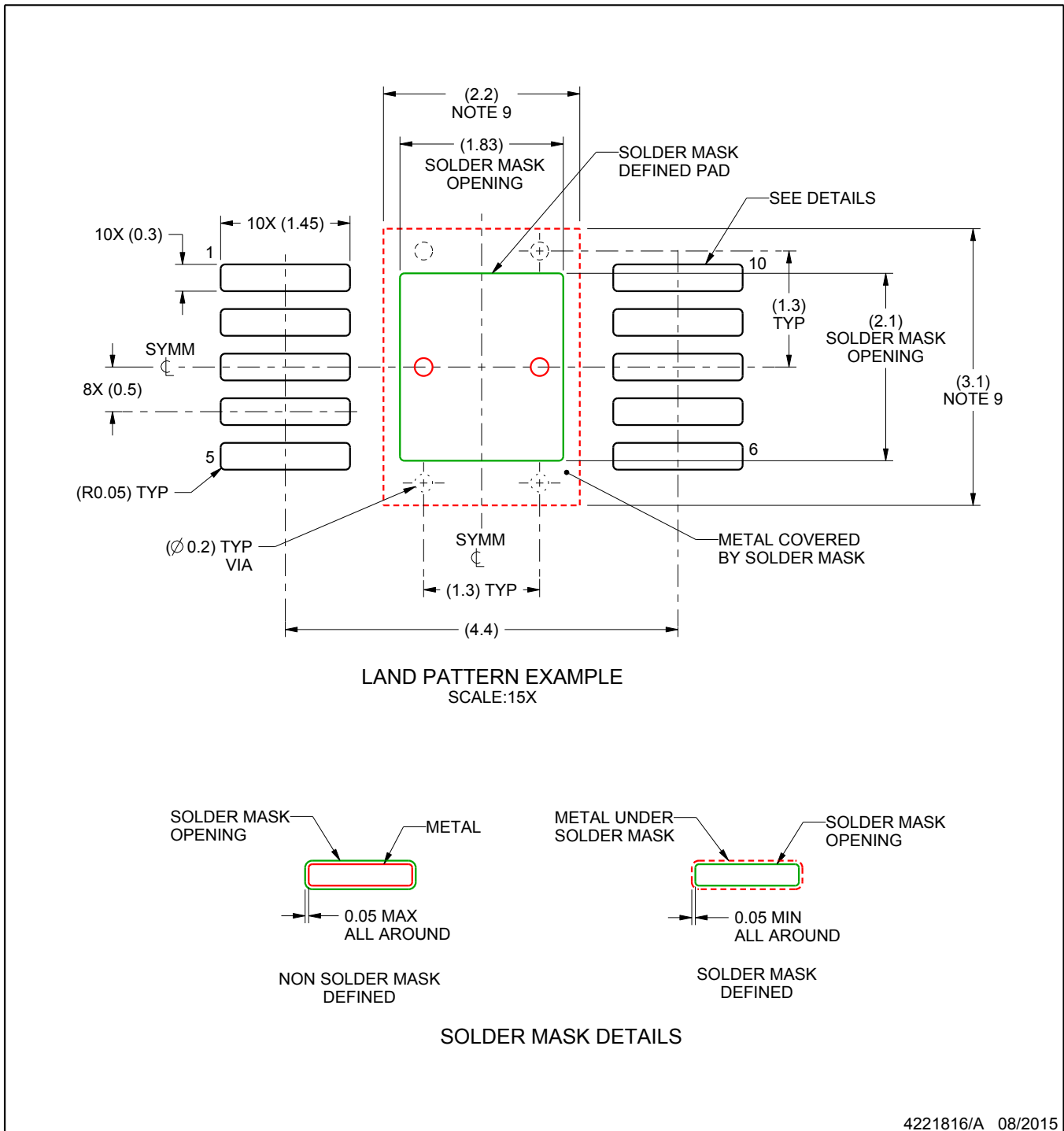

4221816/A 08/2015

NOTES: (continued)

6. Publication IPC-7351 may have alternate designs.
7. Solder mask tolerances between and around signal pads can vary based on board fabrication site.
8. This package is designed to be soldered to a thermal pad on the board. For more information, see Texas Instruments literature numbers SLMA002 ([www.ti.com/lit/slma002](http://www.ti.com/lit/slma002)) and SLMA004 ([www.ti.com/lit/slma004](http://www.ti.com/lit/slma004)).
9. Size of metal pad may vary due to creepage requirement.

# EXAMPLE STENCIL DESIGN

DGQ0010E

PowerPAD™ - 1.1 mm max height

PLASTIC SMALL OUTLINE

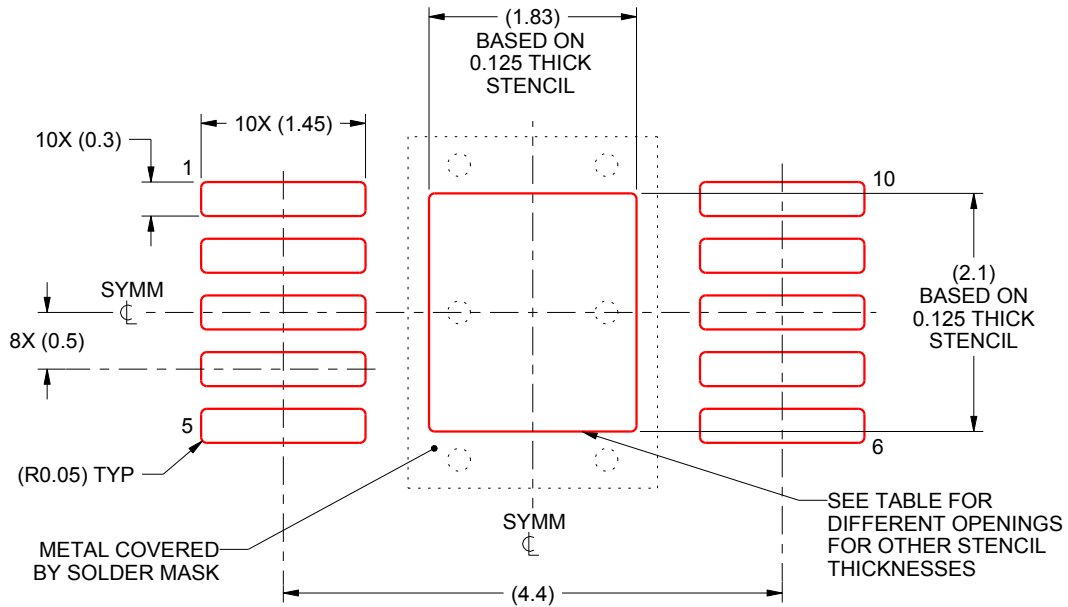

SOLDER PASTE EXAMPLE  
EXPOSED PAD  
100% PRINTED SOLDER COVERAGE BY AREA  
SCALE:15X

| STENCIL THICKNESS | SOLDER STENCIL OPENING |
|-------------------|------------------------|
| 0.1               | 2.05 X 2.35            |
| 0.125             | 1.83 X 2.1 (SHOWN)     |
| 0.150             | 1.67 X 1.92            |
| 0.175             | 1.55 X 1.77            |

4221816/A 08/2015

NOTES: (continued)

10. Laser cutting apertures with trapezoidal walls and rounded corners may offer better paste release. IPC-7525 may have alternate design recommendations.
11. Board assembly site may have different recommendations for stencil design.

## GENERIC PACKAGE VIEW

**DRC 10**

**VSON - 1 mm max height**

3 x 3, 0.5 mm pitch

PLASTIC SMALL OUTLINE - NO LEAD

This image is a representation of the package family, actual package may vary.  
Refer to the product data sheet for package details.

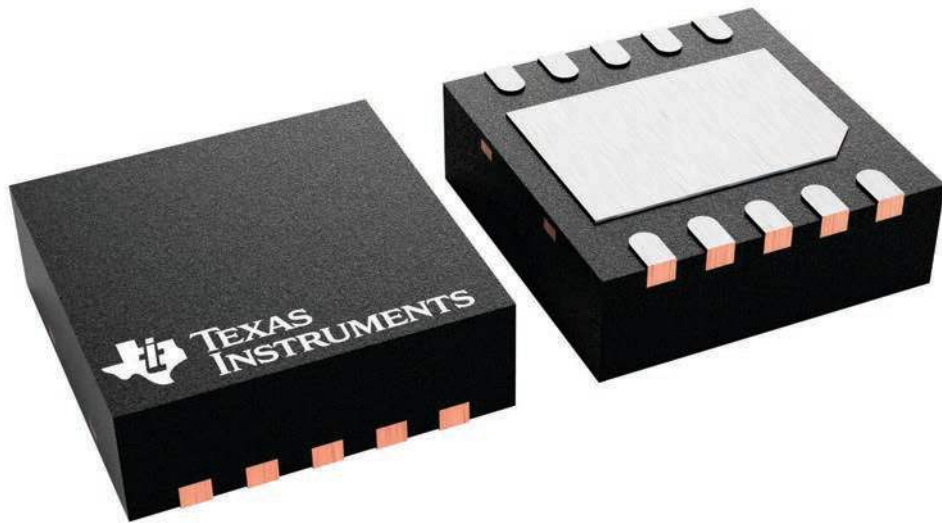

4226193/A





# EXAMPLE BOARD LAYOUT

DRC0010J

VSON - 1 mm max height

PLASTIC SMALL OUTLINE - NO LEAD

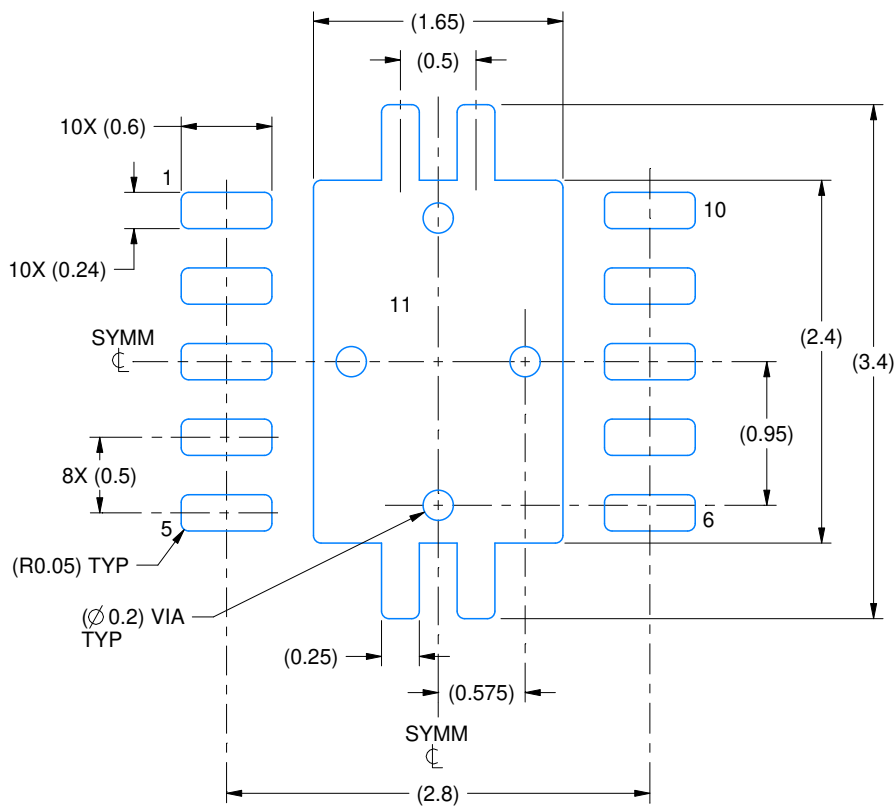

LAND PATTERN EXAMPLE  
EXPOSED METAL SHOWN  
SCALE:20X

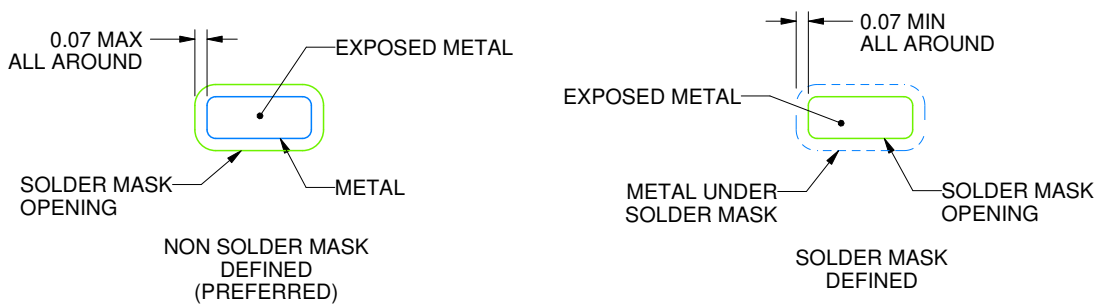

SOLDER MASK DETAILS

4218878/B 07/2018

NOTES: (continued)

4. This package is designed to be soldered to a thermal pad on the board. For more information, see Texas Instruments literature number SLUA271 ([www.ti.com/lit/sluea271](http://www.ti.com/lit/sluea271)).
5. Vias are optional depending on application, refer to device data sheet. If any vias are implemented, refer to their locations shown on this view. It is recommended that vias under paste be filled, plugged or tented.



## IMPORTANT NOTICE AND DISCLAIMER

TI PROVIDES TECHNICAL AND RELIABILITY DATA (INCLUDING DATA SHEETS), DESIGN RESOURCES (INCLUDING REFERENCE DESIGNS), APPLICATION OR OTHER DESIGN ADVICE, WEB TOOLS, SAFETY INFORMATION, AND OTHER RESOURCES "AS IS" AND WITH ALL FAULTS, AND DISCLAIMS ALL WARRANTIES, EXPRESS AND IMPLIED, INCLUDING WITHOUT LIMITATION ANY IMPLIED WARRANTIES OF MERCHANTABILITY, FITNESS FOR A PARTICULAR PURPOSE OR NON-INFRINGEMENT OF THIRD PARTY INTELLECTUAL PROPERTY RIGHTS.

These resources are intended for skilled developers designing with TI products. You are solely responsible for (1) selecting the appropriate TI products for your application, (2) designing, validating and testing your application, and (3) ensuring your application meets applicable standards, and any other safety, security, regulatory or other requirements.

These resources are subject to change without notice. TI grants you permission to use these resources only for development of an application that uses the TI products described in the resource. Other reproduction and display of these resources is prohibited. No license is granted to any other TI intellectual property right or to any third party intellectual property right. TI disclaims responsibility for, and you will fully indemnify TI and its representatives against, any claims, damages, costs, losses, and liabilities arising out of your use of these resources.

TI's products are provided subject to [TI's Terms of Sale](#) or other applicable terms available either on [ti.com](https://www.ti.com) or provided in conjunction with such TI products. TI's provision of these resources does not expand or otherwise alter TI's applicable warranties or warranty disclaimers for TI products.

TI objects to and rejects any additional or different terms you may have proposed.

Mailing Address: Texas Instruments, Post Office Box 655303, Dallas, Texas 75265  
Copyright © 2023, Texas Instruments Incorporated