

© COPYRIGHT 1969 BY AMP INCORPORATED, HARRISBURG, PA.
ALL INTERNATIONAL RIGHTS RESERVED. AMP INCORPORATED PRODUCTS
COVERED BY U. S. AND FOREIGN PATENTS AND/OR PATENTS PENDING.

UNPUBLISHED COPY NOT TO BE
REPRODUCED NOR PUBLISHED
WITHOUT WRITTEN PERMISSION
OF AMP INCORPORATED.

REVISIONS						
P	F	ZONE	LTR	DESCRIPTION	DATE	APPROVED
			B	REVISED & REDRAWN	LAB 10-12-73	LPA
			C	REV "C" DIM PER ECN 4118	11-18-73	RE J.M.
			D	ADDED AMP P/N & DATE CODE	8-23-76	M.B.
			E	ADDED ±.010 TO "C" DIM	10/31/77	M.B.
			F	ADDED REF. TO .17 DIA. & 1.75 ±.25	12-1-77	M.B.
			G	UP-DATED ECN 8357	8-23-78	M.B.
			H	OBSOLETE -2 ECN 53622	11-18-86	R.S.
			J	REV PER ECN S-3960	4-13-87	R.S.
			K	REV PER DF-2688	1/8/90	Ran Baby
			L	REV PER OH14-0192-05	1-06	PY

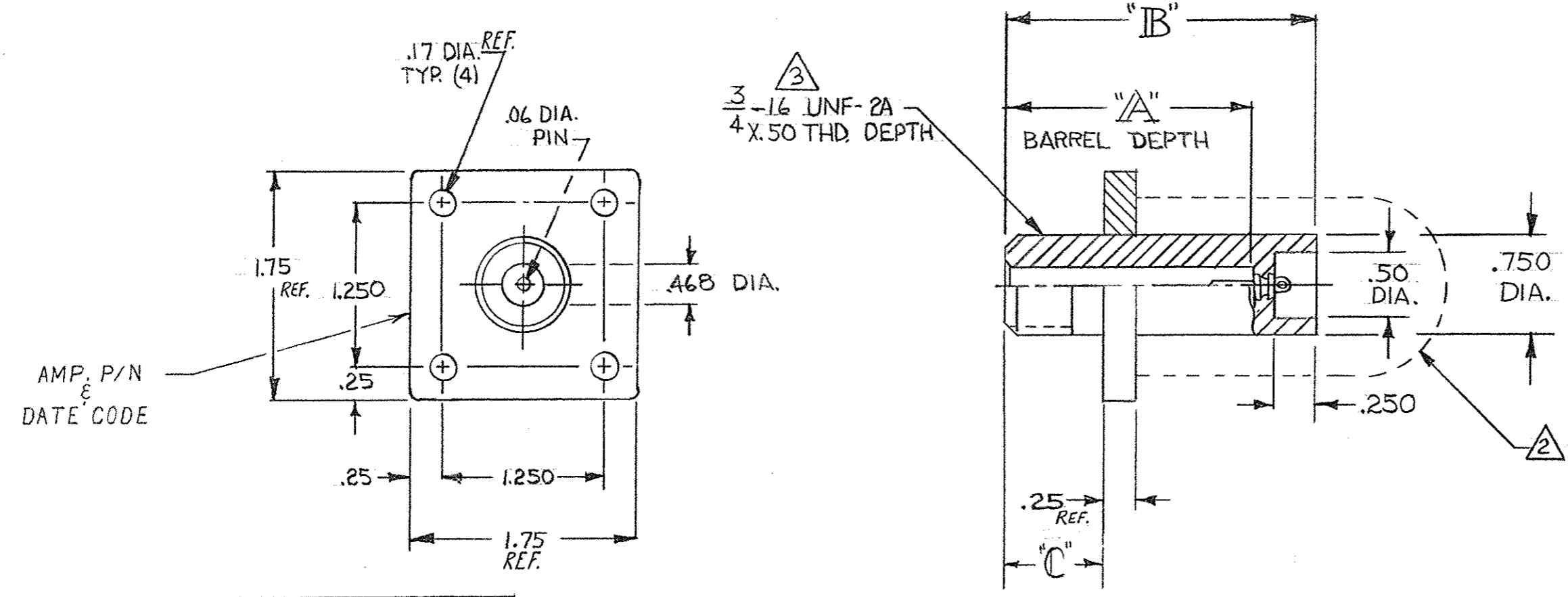

AMP P/N & DATE CODE

PART NO.	"A"	"B"	"C"	TERM. CONTACT PLATING		
				TIN-LEAD	GOLD	TIN
850910-1	1.43	1.812	.562	X		
850910-2	1.43	1.812	.562		X	
5-850910-1	1.43	1.812	.562			X

1. RECEPTACLE TO MATE WITH AMP LGH 2 LEAD ASSEMBLY, AVAILABLE SEPARATELY.

2. CUSTOMER MUST PROTECT THE RECEPTACLES BACK END AGAINST ARC OVER & BREAKDOWN.

3. PER FEDERAL STANDARD H-28 3 WIRE METHOD, DIMENSION OVER WIRES TO BE: .7474-.7654.

				UNLESS OTHERWISE SPECIFIED DIMENSIONS ARE IN INCHES. TOLERANCES: .00 ±.04 .000 ±.015 ANGLES ±		CONTRACT NO DR D.E. CRABB 1-30-69		PART NO	
				MATERIAL MOLDED GLASS EPOXY (BLACK)		CHK		AMP INCORPORATED Elizabethtown, Pa.	
				FINISH		APPD J.W.GAW 1-31-69		NAME FLANGED RECEPTACLE (FOR BULKHEAD APPLICATION)	
NEXT ASSY		FINAL ASSY		NEXT ASSY		USED ON		DSGN APPD	
QTY REQD		APPLICATION				OTHER APPD		SIZE CODE IDENT NO NUMBER C 00779 850910	
								SCALE WT SHEET 1 of 1	