

Specification

Small Form Factor

Duplex LC Receptacle – SFF

Optical Transceivers

STM-1 / OC-3 / 100BASE
 155.52Mbit/s



Ordering Information

T S P - F x A A 1 - M 2 1

Voltage / Temperature

1: 3.3V / +0°C ~ +70°C

2: 3.3V / -40°C ~ +85°C

Model Name	Voltage	Category	Device type	Interface	SD/LOS	Temperature	Distance
TSP-F1AA1-M21	3.3V	W/O DDMI	FP / PIN	DC / DC Coupling	LVPECL	+0°C ~ +70°C	60Km
TSP-F2AA1-M21						-40°C ~ +85°C	

Table 1

Features

- ROHS Compliant
- Standard Small Form Factor Package – SFF MSA Compliant
- SONET/SDH Standard Compliant
- Fast Ethernet Standard Compliant
- Laser Class 1 Product – IEC60825-1 Compliant
- Standard Duplex LC Receptacle Optical Interface
- Single + 3.3 V Power Supply
- Differential LVPECL Data Input and Output
- LVPECL Signal Detect
- Low Power Consumption

Absolute Maximum Ratings

Parameter	Symbol	Min	Typ	Max	Unit
Storage temperature	T_S	-40		85	°C
Supply voltage	V_{CC}	0		4	V
Operating Relative Humidity	-	5		95	%
Input voltage	V_{IN}	0		V_{CC}	V

Operating Conditions

Parameter	Symbol	Min	Typ	Max	Unit
Supply Voltage	V_{CC}	3.1	3.3	3.5	V
Operating Case temperature (TSP-F1AA1-M21)	T_c	0		70	°C
Operating Case temperature (TSP-F2AA1-M21)		-40		85	
Total Current (Transmitter + Receiver)	I_{CC}	-	-	250	mA
Hand Lead Soldering Temperature / Time	T_h	-		260/10	°C /sec
Wave Lead Soldering Temperature / Time	T_w	-		260/10	°C /sec

Transmitter Specifications ($V_{CC}=3.1V\sim 3.5V$; $T_C= 0^{\circ}C\sim 70^{\circ}C$ / $T_C= -40^{\circ}C\sim 85^{\circ}C$)

Parameter	Symbol	Min	Typ	Max	Unit
Optical Characteristics					
Output Optical Power	P_{out}	-5	--	0	dBm
Extinction Ratio	ER	9	--	--	dB
Center Wavelength	λ_C	1270	1310	1355	nm
Spectral Width (RMS)	σ	--	--	2.5	nm
Rise/Fall time (10-90%)	$T_{r,f}$	--	--	2	ns
Relative Intensity Noise	RIN	--	--	-120	dB/Hz
Output Eye	Compliant with IEEE 802.3z				
Max. P_{out} TX-DISABLE Asserted	P_{OFF}	--	--	-45	dBm
Electrical Characteristics					
Transmitter Data Input Voltage - High	$V_{IH} - V_{CC}$	-1.1	--	-0.74	V
Transmitter Data Input Voltage - Low	$V_{IL} - V_{CC}$	-2.0	--	-1.58	V
Tx_Disable_Input_High	V_{DISH}	2.0	--	$V_{CC}+0.3$	V
Tx_Disable_Input_Low	V_{DISL}	0	--	0.8	V

Receiver Specifications ($V_{CC}=3.1V\sim 3.5V$; $T_C= 0^{\circ}C\sim 70^{\circ}C$ / $T_C= -40^{\circ}C\sim 85^{\circ}C$)

Parameter	Symbol	Min	Typ	Max	Unit
Optical Characteristics					
Optical Input Power-maximum	P_{SATIN}	-3	--	--	dBm
Receiver Sensitivity (PRBS= $2^{23}-1$; BER $\leq 10^{-10}$)	P_{SEN}	--	--	-35	dBm
Operating Center Wavelength	λ_C	1260	--	1610	nm
Signal Detect – Asserted	P_{SA}	--	--	-35	dBm
Signal Detect – De-asserted	P_{SD}	-45	--	--	dBm
Signal Detect – Hysteresis	P_{SH}	0.5	--	6	dB
Electrical Characteristics					
Differential Output Voltage	V_{DIFF}	0.4	--	2.0	V
Signal Detect Output Voltage - High	$V_{OH} - V_{CC}$	-1.1	--	-0.74	V
Signal Detect Output Voltage - Low	$V_{OL} - V_{CC}$	-2.0	--	-1.58	V

Pin Definition and Descriptions

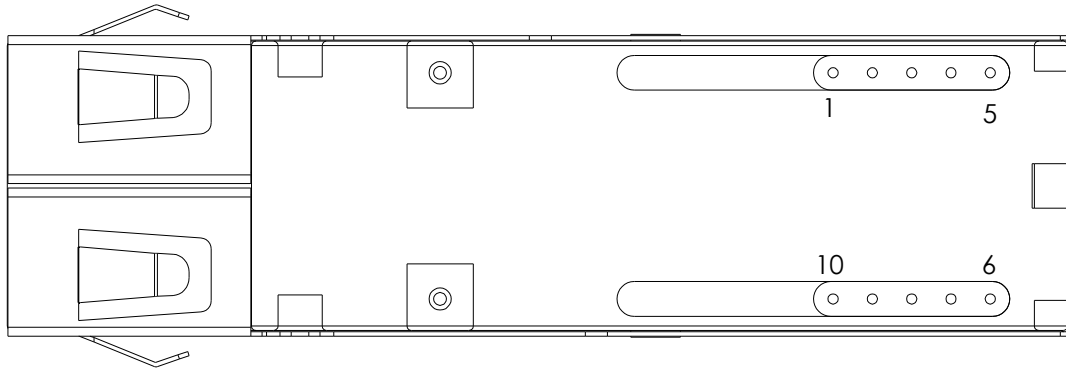

Bottom View

Pin	Name	Input-Output /Level	Description	Ref.
1	VEER	Input	Receiver ground	
2	VCCR	Input	Receiver power supply	
3	SD	Output/LVPECL	Receiver signal detect. High signal indicates optical signal is present at receiver input.	
4	RD-	Output/LVPECL	Inverted receiver data output	
5	RD+	Output/LVPECL	Non-inverted receiver data output	
6	VCCT	Input	Transmitter power supply	
7	VEET	Input	Transmitter ground	
8	DIS	Input/LVTTL	Transmitter Disable Control	
9	TD+	Input/LVPECL	Transmitter non-inverted data input	
10	TD-	Input/LVPECL	Transmitter inverted data input	

Recommended Circuit Diagram

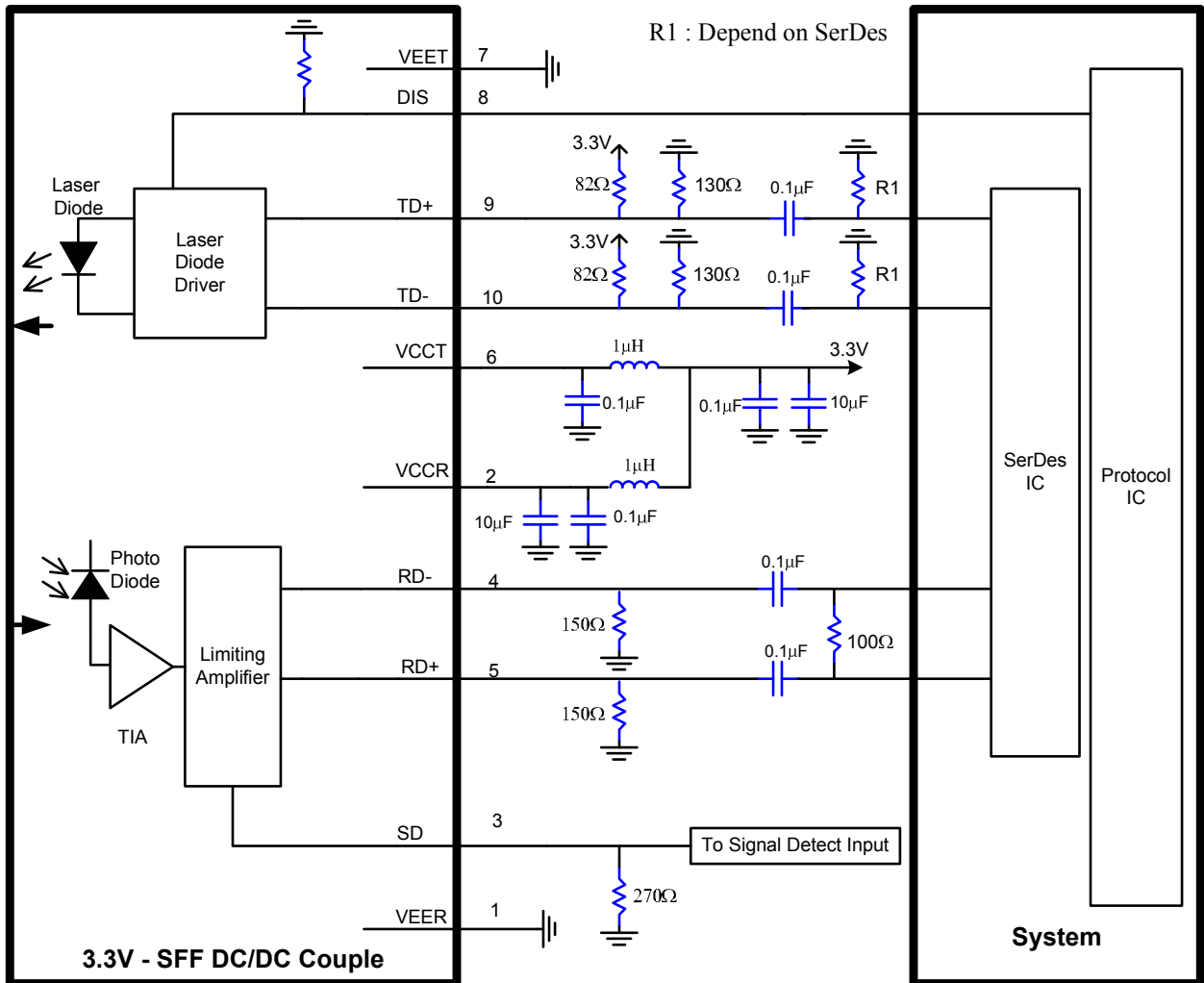

Mechanical Outlines

(Unit : mm)

