

PART NUMBER	REV	FIRST USED
672180-4	T	1-471273-3

- 1 RECOMMENDED SPARE PARTS.
- 2 CRIMP HEIGHT FOR INITIAL SET-UP ONLY.

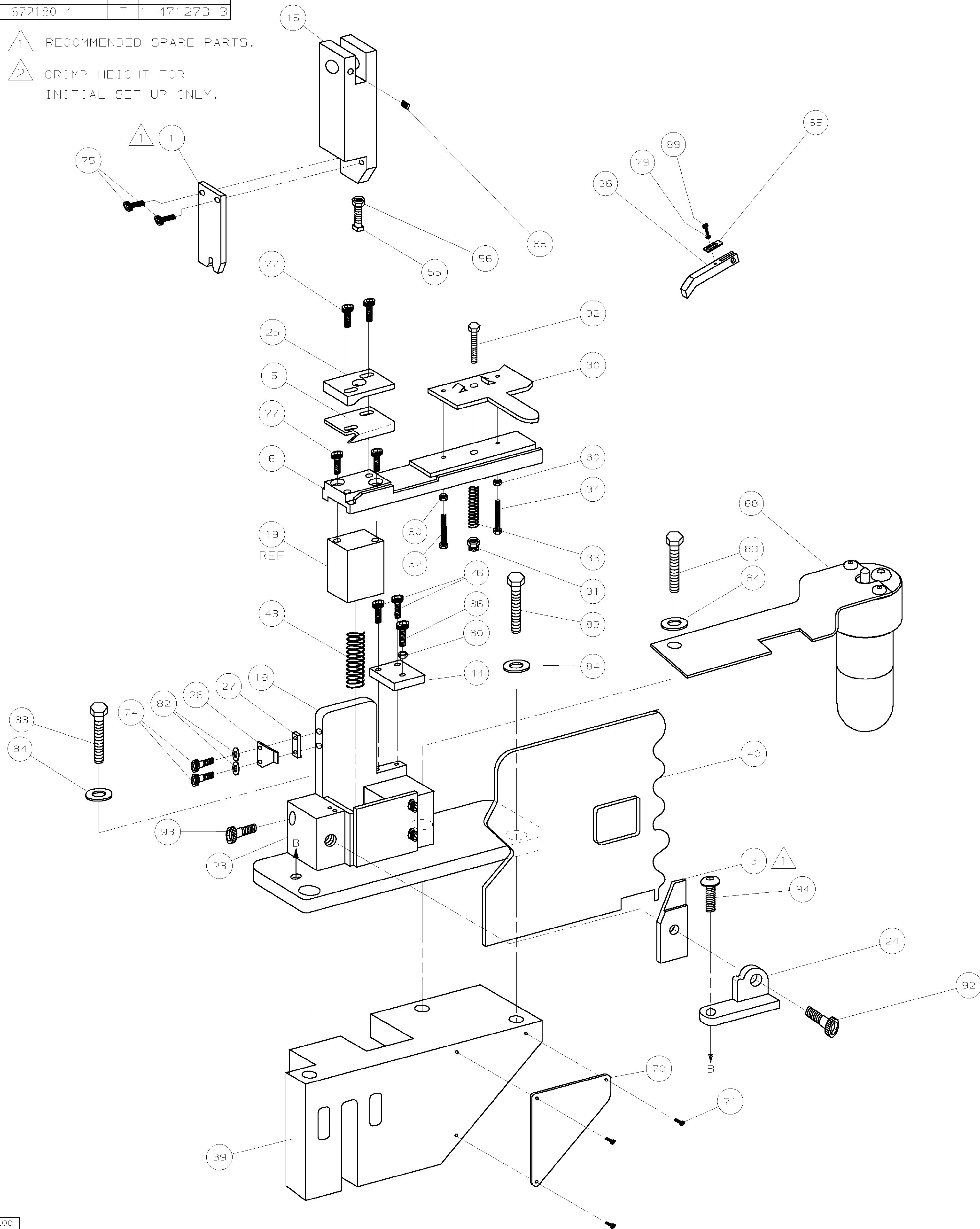

TERMINAL NAME:	
LENGTHWISE THRU SPLICE	
	40509
	40552
	40952
	40978
	42230
	60470
	60916
	62919
TERM APPL SPEC	114-2088

CRIMPING DATA			
CRIMP HEIGHT	WIRE SIZE		
.090	(2) 16		
CRIMP	SIZE	TYPE	RANGE
WIRE	.140	F	3232-8282 CMA
INSUL			
FEED	APPL INST	SET UP GAGE	LAYOUT
.217			
WIRE STRIP LENGTH	.140-.170		

-	-	-	-	-	129
-	-	-	-	-	128
-	-	-	-	-	127
-	-	-	-	-	126
-	-	-	-	-	125
-	-	-	-	-	124
-	-	-	-	-	123
-	-	-	-	-	122
-	-	-	-	-	121
-	-	-	-	-	120
-	-	-	-	-	119
-	-	-	-	-	118
-	-	-	-	-	117
-	-	-	-	-	116
-	-	-	-	-	115
-	-	-	-	-	114
-	-	-	-	-	113
-	-	-	-	-	112
-	-	-	-	-	111
-	-	-	-	-	110
-	-	-	-	-	109
-	-	-	-	-	108
-	-	-	-	-	107
-	-	-	-	-	106
-	-	-	-	-	105
-	-	-	-	-	104
-	-	-	-	-	103
-	-	-	-	-	102
-	-	-	-	-	101
-	-	-	-	-	100
-	-	-	-	-	99
-	-	-	-	-	98
-	-	-	-	-	97
-	-	-	-	-	96
-	-	-	-	-	95
1	-	A	4-21002-1	SCR, BSHC 5/16-18 x .75	94
1	-	A	3-21001-4	SCR, SHC, 3/8-16 X .88	93
1	-	A	21001-5	SCR, SHC, 1/4-20 X .88	92
-	-	-	-	-	91
-	-	-	-	-	90
1	-	A	2-21000-5	SCR, SHC, 8-32 X .25	89
-	-	-	-	-	88
-	-	-	-	-	87
1	-	A	3-21000-9	SCR, SHC, 10-32 x 1.00	86
1	-	A	2-21549-3	SCR, SOC SET, 1/4-20 X .25	85
3	-	A	371178	WASHER, FLAT, 3/8	84
3	-	A	3-21015-2	SCR, HEX HD, 3/8-16 X 1.25	83
2	-	A	21055-7	WASHER, FLAT, 10	82
-	-	-	-	-	81
3	-	A	21018-7	NUT, HEX 10-32	80
1	-	A	21055-6	WASHER, FLAT, #8	79
-	-	-	-	-	78
4	-	A	3-21000-6	SCR, SHC, 10-32 X .62	77
2	-	A	3-21000-4	SCR, SHC, 10-32 X .38	76
2	-	A	21001-2	SCR, SHC, 1/4-20 X .62	75
2	-	A	3-21000-5	SCR, SHC, 10-32 x .50	74

-	-	-	-	-	73
-	-	-	-	-	72
3	-	A	21017-6	SCREW, DRIVE 4-40 X .25	71
1	-	C	452373-1	PLATE, IDENTIFICATION	70
-	-	-	-	-	69
1	-	C	465184-2	LUBRICATOR ASSY	68
-	-	-	-	-	67
-	-	-	-	-	66
1	-	A	374999	TENSION ADJ PLATE	65
-	-	-	-	-	64
-	-	-	-	-	63
-	-	-	-	-	62
-	-	-	-	-	61
-	-	-	-	-	60
-	-	-	-	-	59
-	-	-	-	-	58
-	-	-	-	-	57
1	-	A	22202-1	NUT, HEX JAM, 1/4-20	56
1	-	A	21077-7	SCR, SQ HD SET, 1/4-20 X 1.50	55
-	-	-	-	-	54
-	-	-	-	-	53
-	-	-	-	-	52
-	-	-	-	-	51
-	-	-	-	-	50
-	-	-	-	-	49
-	-	-	-	-	48
-	-	-	-	-	47
-	-	-	-	-	46
-	-	-	-	-	45
1	-	B	372998	RETAINER, FEED PLATE	44
1	-	A	2-24017-7	SPRING SLIDE	43
-	-	-	-	-	42
-	-	-	-	-	41
1	-	B	460582-1	GUARD	40
1	-	C	570238	BASE CASTING	39
-	-	-	-	-	38
-	-	-	-	-	37
1	-	B	811432-1	FEED FINGER	36
-	-	-	-	-	35
2	-	A	372997	ADJ. SCREW, STOCK DRAG	34
1	-	A	23846-7	SPRING, STOCK DRAG	33
1	-	A	21015-8	STUD, STOCK DRAG	32
1	-	A	21022-4	NUT, STOCK DRAG HANDLE	31
1	-	A	372990	STOCK DRAG	30
-	-	-	-	-	29
-	-	-	-	-	28
1	-	A	375569	SPACER, CLEANER	27
1	-	A	810995-2	STRIPPER	26
1	-	B	376945	WIRE GUIDE	25
1	-	B	378975	AUX. ANVIL HOLDER	24
1	-	A	374348	ANVIL HOLDER	23
-	-	-	-	-	22
-	-	-	-	-	21
-	-	-	-	-	20
1	-	C	473933	APPLICATOR MOUNT ASSY	19
-	-	-	-	-	18
-	-	-	-	-	17
-	-	-	-	-	16
1	-	B	471057	RAM	15
-	-	-	-	-	14
-	-	-	-	-	13
-	-	-	-	-	12
-	-	-	-	-	11
-	-	-	-	-	10
-	-	-	-	-	9
-	-	-	-	-	8
-	-	-	-	-	7
1	-	A	373158	PLATE, FEED	6
1	-	B	376894	BLADE, SHEAR	5
-	-	-	-	-	4
1	-	B	375147	ANVIL	3
-	-	-	-	-	2
1	-	C	1-453922-1	CRIMPER, WIRE	1

THIS DRAWING IS A CONTROLLED DOCUMENT.

.JIS

RELEASED FOR PUBLICATION BY AMP INCORPORATED. ALL RIGHTS RESERVED.

THIS DRAWING IS UNRELEASED. COPYRIGHT 19

LOC A DIST 4

QTY	RECD	PER	ASSY	PARTS LIST
-4	U/M	DWG SIZE	PART NO	DESCRIPTION
REVISION OF EACH ASSY NO (WHEN BLANK, USE DWG REVISION)				

QTY	RECD	PER	ASSY	PARTS LIST
-4	U/M	DWG SIZE	PART NO	DESCRIPTION
REVISION OF EACH ASSY NO (WHEN BLANK, USE DWG REVISION)				

DIMENSIONS IN INCHES. DO NOT SCALE PRINT. TOLERANCES UNLESS OTHERWISE SPECIFIED:		MACHINE REF STD APPL	
2 PLC DEC ±	3 PLC DEC ±	4 PLC DEC ±	
ANGLES ±	SURF TEXTURE: ✓	REMOVE BURRS, BREAK SHARP EDGES R.015 MAX	
DR 5/17/93	APP 2-16-94	R. LEHR/UTA	B WOLFE
CHK 2-16-94	REL 3/10/94	C ERISMAN	B. MORGAN
NAME		END FEED STANDARD APPLICATOR	
SCALE 1:4	DWG NO 672180-4	SHEET 1 OF 1	REV T1