

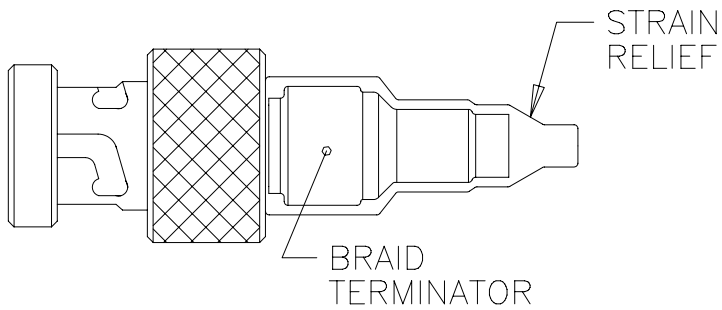

REVISIONS			
LTR	DESCRIPTION	DATE	APPROVED
B	COMPILED AND REDRAWN ON CAD PER ECN# T-15296	90 NOV 8	Z. TEMAN
C	REVISED PER ECN# T-16826	91 OCT 21	Z. TEMAN
D	REVISED AND RENAMED PER ECN# T-20892 "WAS" D-621-X033/X040	96 JUL 15	Z. TEMAN

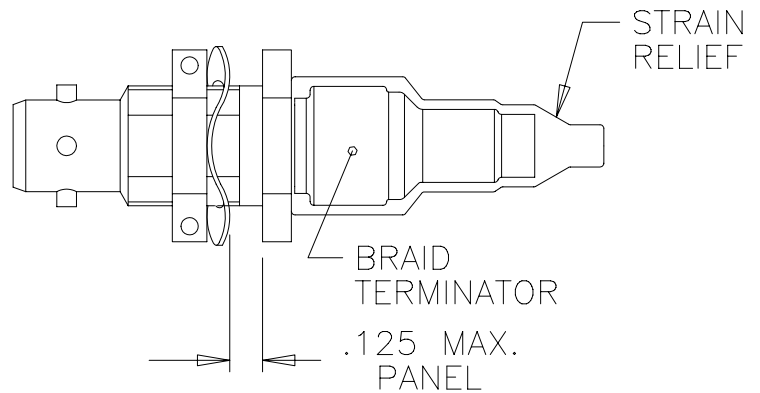

PLUG



JACK

CONNECTOR	INTERFACE	QUANTITY
D-621-0033 PLUG	"A" PER FIGURE	1
D-621-0034 JACK	"A" PER FIGURE	2
D-621-0035 PLUG	"B" PER FIGURE	3
D-621-0036 JACK	"B" PER FIGURE	4
D-621-0037 PLUG	"C" PER FIGURE	5
D-621-0038 JACK	"C" PER FIGURE	6
D-621-0039 PLUG	"D" PER FIGURE	7
D-621-0040 JACK	"D" PER FIGURE	8

JACK MOUNTING HOLE (PREFERRED)

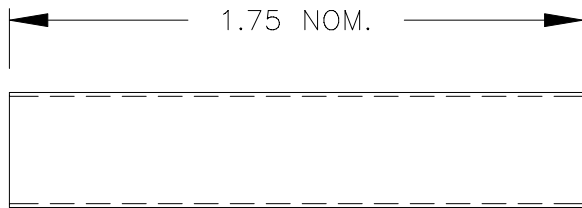
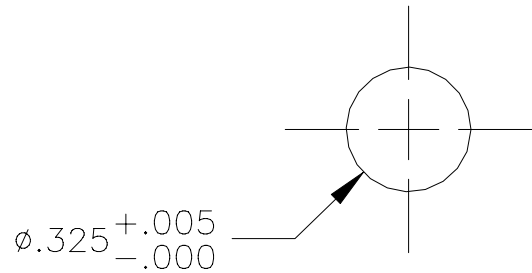

UNRECOVERED STRAIN RELIEF: D-600-0019

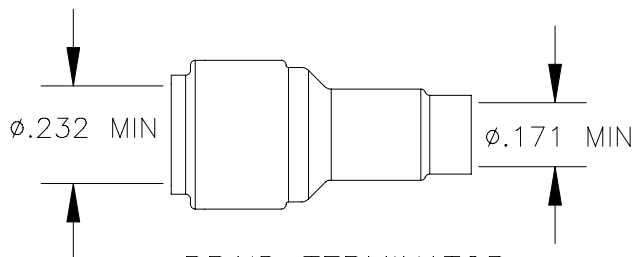

BRAID TERMINATOR
D-600-0032

SPECIFICATION CONTROL DRAWING

If this document is printed it becomes uncontrolled.
Check with the web for latest revision.

UNLESS OTHERWISE SPECIFIED
DIMENSIONS ARE IN INCHES.
METRIC DIMENSIONS ARE
IN BRACKETS.

DECIMALS
 $.XXX \pm \text{---}$ [--- mm]
 $.XX \pm \text{---}$ [--- mm]
 ANGLES
 $.X \pm \text{---}$
 WEIGHT
 --- lbs [--- g]

DRAWN	J.B.K.	90 NOV 6
CHECKED		
APPROVED		
APPROVED	Z.TEMAN	90 NOV 8
CAD NAME 004993-1		
THIRD ANGLE PROJECTION		

Raychem

RAYCHEM CORPORATION
300 CONSTITUTION DRIVE
MENLO PARK, CALIFORNIA 94025

TITLE CONNECTOR, TRIAXIAL, SUBMINIATURE, BAYONET COUPLED			
SIZE A	CODE IDENT. NO. 06090	DWG. NO. D-621-0033/0040	REV D
DO NOT SCALE THIS DRAWING		SHEET 1 OF 3	



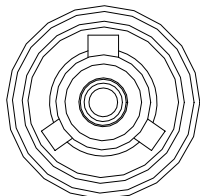
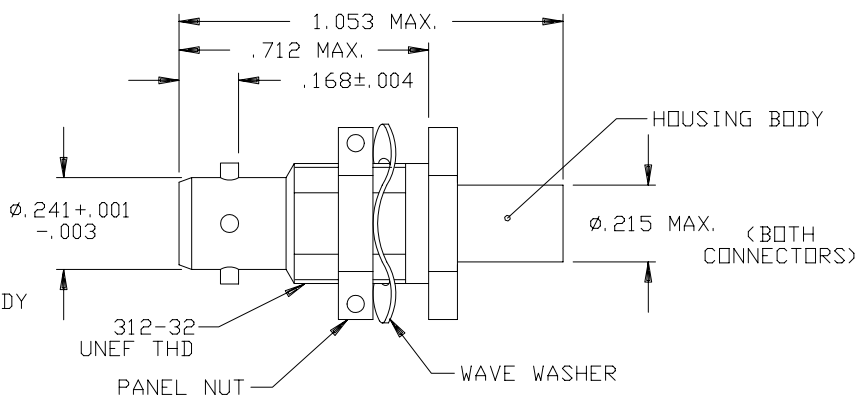
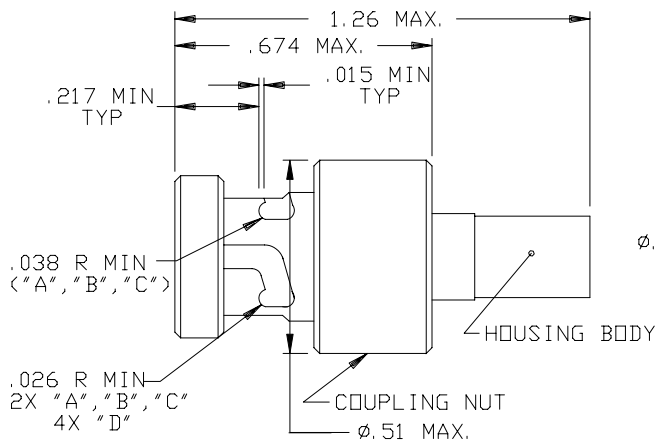

FIGURE 1 "A"

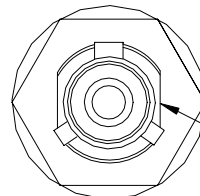

FIGURE 2 "A"

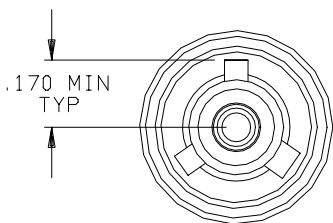

FIGURE 3 "B"

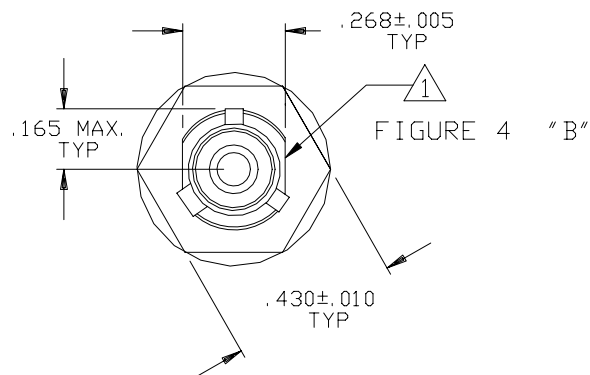

FIGURE 4 "B"

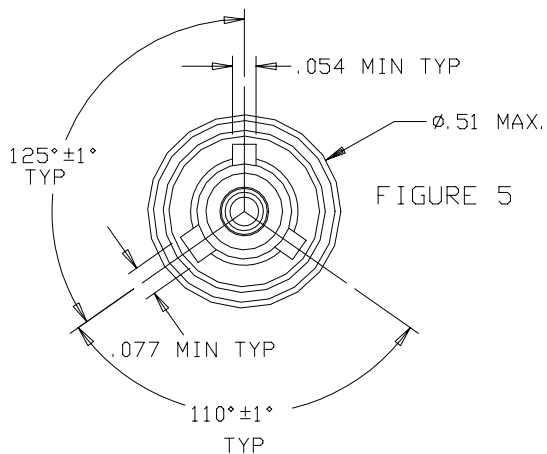

FIGURE 5 "C"

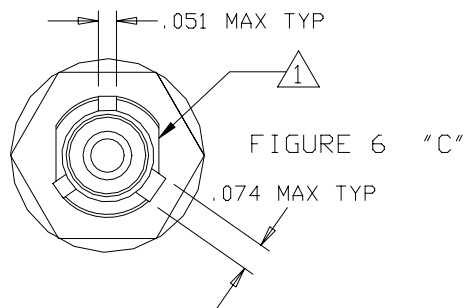

FIGURE 6 "C"

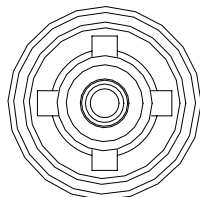

FIGURE 7 "D"

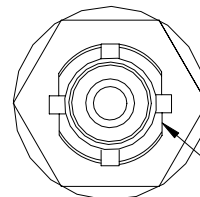

FIGURE 8 "D"

INTERFACE

△ MAJOR KEY ORIENTATION WITH RESPECT TO FLATS, IS NOT CONTROLLED.

**If this document is printed it becomes uncontrolled.
Check with the web for latest revision.**

NOTES:

CAD NAME: 004993-2	DRAWN	J. B. K.	90 NOV 6	SIZE	CODE IDENT. NO.	DWG. NO.	REV
	ISSUED			A	06090	D-621-0033/0040	D
DO NOT SCALE THIS DRAWING						SHEET 2 OF 3	

SPECIFICATIONS

SEE SHEET 1 FOR REVISION

1.0 MATERIALS AND FINISHES

- 1.1 HOUSING BODY: BeCu ALLOY, ASTM B196, TB00 OR TD04,
TIN PLATED PER MIL-T-10727 TYPE I,
OVER NICKEL PER MIL-C-26074
- 1.1.1 INSULATION (MIP): POLYETHERSULFONE
- 1.2 COUPLING NUT (PLUG): BeCu ALLOY, ASTM B196, TB00 OR TD04,
NICKEL PER MIL-C-26074
- 1.3 PANEL NUT (JACK): BRASS ALLOY PER ASTM B16,
NICKEL PLATED PER MIL-C-26074
- 1.4 WAVE WASHER (JACK): BeCu PER ASTM B194
NICKEL PLATED PER QQ-N-290

1.5 BRAID TERMINATOR

- 1.5.1 BODY: BRASS ALLOY PER ASTM B16, TIN-LEAD PLATED
PER MIL-P-81728A
- 1.5.2 SOLDER PREFORM: Sn63 PER QQ-S-571
- 1.5.3 INSULATION SLEEVE: POLYVINYLIDENE FLUORIDE
- 1.6 STRAIN RELIEF: WHITE RNF-100 WITH ADHESIVE

2.0 CONTACTS

CABLE TYPE	TRIAxIAL	TWINAXIAL	COAXIAL
CONTACT(S)	D-602-44 (PIN) D-602-45 (SOCKET)	D-602-0126 (PIN) D-602-0127 (SOCKET)	D-610-09 (PIN) D-610-10 (SOCKET)

3.0 SEE ES61162 FOR CABLE ACCOMODATION AND TERMINATION INFORMATION.

4.0 PERFORMANCE REQUIREMENTS

4.1 REFER TO RAYCHEM SPECIFICATION D-6025 FOR PRODUCT PERFORMANCE AND
QUAILIFICATION REQUIREMENTS.

5.0 GENERAL CHARACTERISTICS

- 5.1 OPERATING TEMPERATURE: -65°C TO 125°C
- 5.2 INSULATION RESISTANCE: GREATER THAN 5K MEG
- 5.3 DIELECTRIC STRENGTH: 900 VAC @ 60 Hz
- 5.4 CURRENT RATING: 3 AMPS MAX.
- 5.5 CONTACT RESISTANCE: INITIAL: 8 MILLIOHMS MAX.
- 5.6 PANEL NUT TORQUE (JACK): 10-15 INCH/LBS (WHEN INSTALLING IN PANEL)

6.0 RAYCHEM CABLES (CONSULT RAYCHEM FOR OTHER CABLE REQUIREMENTS)

- 10602
- 10605
- 10612
- 10613
- 10614

**If this document is printed it becomes uncontrolled.
Check with the web for latest revision.**

CAD NAME: 004993-3	DRAWN	J. B. K.	90 NOV 6	SIZE	CODE IDENT. NO.	DWG. NO.	REV
	ISSUED			A	06090	D-621-0033/0040	D
DO NOT SCALE THIS DRAWING						SHEET 3 OF 3	