



- **Guaranteed AC performance over temperature and voltage**
 - > 4GHz f_{MAX} input frequency
 - < 240ps t_r/t_f
 - < 500ps T_{PD}
- **3.3V and 5V power supply operation**
- **100k ECL/PECL compatible I/O**
- **Wide operating temperature range: -40°C to +85°C**
- **Available in ultra-small 8-pin MLF® (2mm x 2mm) package**

DESCRIPTION

The SY89313V is a differential ECL/PECL integrated ÷4 divider clock generator. It is functionally equivalent to the SY100EP33V but in an ultra-small 8-lead MLF® package that features a 70% smaller footprint.

The V_{BB} pin, an internally generated voltage supply, is available for this device only. For single-ended input conditions, the unused differential input is connected to V_{BB} as a switching reference voltage. V_{BB} may also re-bias AC-coupled inputs. When used, decouple V_{BB} and V_{CC} via a 0.01µF capacitor and limit current sourcing or sinking to 0.5mA. When not used, V_{BB} should be left open.

The reset pin is asynchronous and is asserted on the rising edge. Upon power-up, the internal flip-flops will be in a random state; the reset allows for the synchronous use of multiple SY89313V's in a system.

PIN CONFIGURATION/BLOCK DIAGRAM

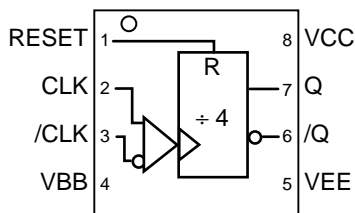

TOP VIEW
8-Pin MLF®

Ultra-Small Outline (2mm x 2mm)

TRUTH TABLE⁽¹⁾

CLK	/CLK	RESET	Q	/Q
X	X	Z	L	H
\uparrow	\downarrow	L	F	F

Note:

1. \uparrow = LOW-to-HIGH transition
 \downarrow = HIGH-to-LOW transition
 F = Divide by 4 function

PACKAGE/ORDERING INFORMATION

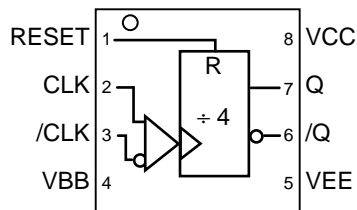

TOP VIEW
8-Pin MLF®

Ultra-Small Outline
(2mm x 2mm)

Ordering Information

Part Number	Package Type	Operating Range	Package Marking	Lead Finish
SY89313VMITR	MLF-8	Industrial	313	Sn-Pb
SY89313VMGTR ⁽¹⁾	MLF-8	Industrial	313 with Pb-Free bar-line indicator	Pb-Free NiPdAu

Note:

1. Pb-Free package is recommended for new designs.

PIN DESCRIPTION

Pin Number	Pin Name	Type	Pin Function
2, 3	CLK, /CLK	100K ECL/PECL Input	Differential PECL/ECL Input: Internal 75kΩ pull-down resistor. If left open, pin defaults LOW. See "Input Interface Applications" section for single-ended inputs.
7, 6	Q, /Q	100K Output	Differential PECL/ECL Output: Output CLK input divided by 4. See "Output Interface Applications" section for recommendations on terminations.
8	VCC	Positive Power Supply	Positive Power Supply: Bypass with 0.1μF//0.01μF low ESR capacitors.
5	VEE, Exposed Pad	Negative Power Supply	Negative Power Supply: V _{EE} and Exposed pad must be tied to most negative supply. For PECL/LVPECL connect to ground.
4	VBB	Reference Voltage Output	Bias Reference Voltage: V _{CC} -1.4V. Used as reference voltage for single-ended input or AC-coupling to the CLK, /CLK inputs. Max sink/source is ±0.5mA. See "Input Interface Applications" section.
1	Reset	100EP Input	Single-ended Input: PECL/ECL Asynchronous reset.

Absolute Maximum Ratings⁽¹⁾

Supply Voltage (V_{CC})	-0.5V to +6.0V
Input Voltage (V_{IN})	-0.5V to V_{CC}
LVPECL Output Current (I_{OUT})		
Continuous	50mA
Surge	100mA
Current (V_{BB})		
Source or sink current on V_{BB} , Note 3	± 1.5 mA
Lead Temperature (soldering, 20 sec.)	+260°C
Storage Temperature (T_S)	-65°C to +150°C

Operating Ratings⁽²⁾

Supply Voltage (V_{CC})	3.0V to 3.6V
	4.5V to 5.5V
Ambient Temperature (T_A)	-40°C to +85°C
Package Thermal Resistance ⁽⁴⁾		
MLF® (θ_{JA})		
Still-Air	93°C/W
500lfpm	~87°C/W
MLF® (Ψ_{JB})		
Junction-to-Board	60°C/W

PECL/ECL (100K) DC ELECTRICAL CHARACTERISTICS

$V_{CC} = +3.3V \pm 10\%$ or $+5V \pm 10\%$ and $V_{EE} = 0V$; $V_{CC} = 0V$ and $V_{EE} = -3.3V \pm 10\%$ or $-5V \pm 10\%$; $R_L = 50\Omega$ to $V_{CC} - 2V$; $T_A = -40^\circ C$ to $+85^\circ C$ unless otherwise noted.

Symbol	Parameter	Condition	Min	Typ	Max	Units
I_{EE}	Power Supply Current	Max V_{CC} , No Load	—	30	40	mA
V_{OH}	Output HIGH Voltage		$V_{CC} - 1.145$	—	$V_{CC} - 0.895$	V
V_{OL}	Output LOW Voltage		$V_{CC} - 1.945$	—	$V_{CC} - 1.695$	V
V_{IH}	Input HIGH Voltage		$V_{CC} - 1.225$	—	$V_{CC} - 0.88$	V
V_{IL}	Input LOW Voltage		$V_{CC} - 1.945$	—	$V_{CC} - 1.625$	V
V_{IHCMR}	Input HIGH Voltage Common Mode Range	Note 5	$V_{EE} + 2.0$	—	V_{CC}	V
V_{BB}	Bias Voltage		$V_{CC} - 1.525$	$V_{CC} - 1.425$	$V_{CC} - 1.325$	V
I_{IH}	Input HIGH Current		—	—	150	μA
I_{IL}	Input LOW Current CLK, RESET		0.5	—	—	μA
	Input LOW Current /CLK		-150	—	—	μA

Notes:

1. Permanent device damage may occur if absolute maximum ratings are exceeded. This is a stress rating only and functional operation is not implied at conditions other than those detailed in the operational sections of this data sheet. Exposure to absolute maximum rating conditions for extended periods may affect device reliability.
2. The data sheet limits are not guaranteed if the device is operated beyond the operating ratings.
3. Due to the limited drive capability use for input of the same package only.
4. Package thermal resistance assumes exposed pad is soldered (or equivalent) to the devices most negative potential on the PCB.
5. V_{IHCMR} (min) varies 1:1 with V_{EE} , (max) varies 1:1 with V_{CC} .

AC ELECTRICAL CHARACTERISTICS⁽⁶⁾

$V_{CC} = +3.3V \pm 10\%$ or $+5V \pm 10\%$ and $V_{EE} = 0V$; $V_{CC} = 0V$ and $V_{EE} = -3.3V \pm 10\%$ or $-5V \pm 10\%$; $R_L = 50\Omega$ to $V_{CC} - 2V$; $T_A = -40^\circ C$ to $+85^\circ C$ unless otherwise noted.

Symbol	Parameter	Condition	Min	Typ	Max	Units
f_{MAX}	Maximum Input Frequency		4	—	—	GHz
t_{PLH} t_{PHL}	Propagation Delay to Output CLK → Q (SY10EP33V) RESET → Q (SY100EP33V) RESET → Q		300 300 310	380 420 420	460 500 500	ps
t_{RR}	Set/Reset Recovery		200	100	—	ps
t_{PW}	Minimum Pulse Width	RESET	550	200	—	ps
t_{JITTER}	Cycle-to-Cycle RMS Jitter		—	—	1	ps _{RMS}
V_{PP}	Input Voltage Swing (Differential)		150	800	1200	mV
t_r t_f	Output Rise/Fall Times (20% to 80%)	Q, /Q	90	180	240	ps

Note:

6. Measured using a 750mV source, 50% duty cycle clock source. All loading with 50Ω to $V_{CC} - 2.0V$.

TIMING DIAGRAM

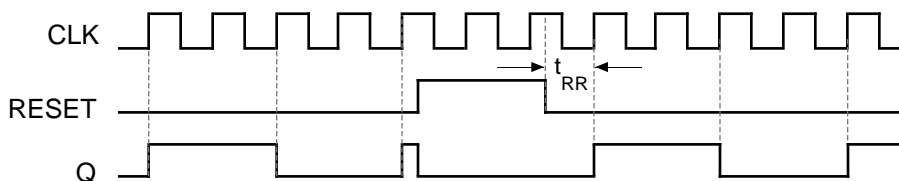

INPUT INTERFACE APPLICATIONS

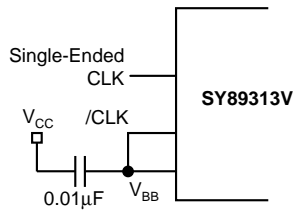

Figure 1. Single-Ended LVPECL Input (Terminating Unused Input)

LVPECL OUTPUT INTERFACE APPLICATIONS

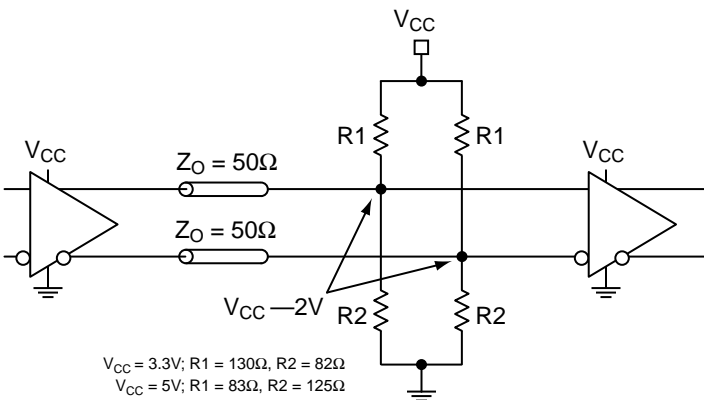

Figure 2a. Parallel Thevenin-Equivalent Termination

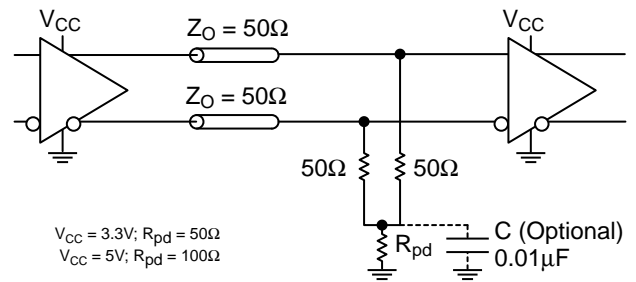

Figure 2b. Three Resistor "Y Termination"

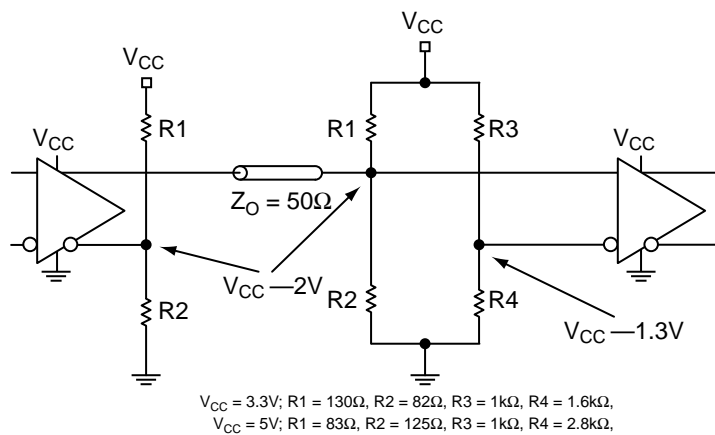
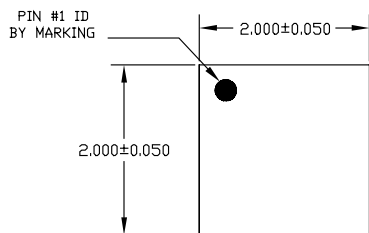
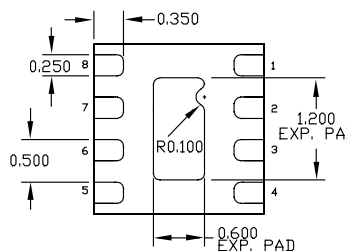

Figure 2c. Terminating Unused I/O

8 LEAD ULTRA-SMALL EPAD-MicroLeadFrame® (MLF-8)



TOP VIEW



BOTTOM VIEW

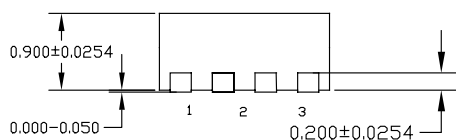

SIDE VIEW

- NOTE:
1. ALL DIMENSIONS ARE IN MILLIMETERS.
 2. MAX. PACKAGE WARPAGE IS 0.05 mm.
 3. MAXIMUM ALLOWABLE BURRS IS 0.076 mm IN ALL DIRECTIONS.
 4. PIN #1 ID ON TOP WILL BE LASER/INK MARKED.

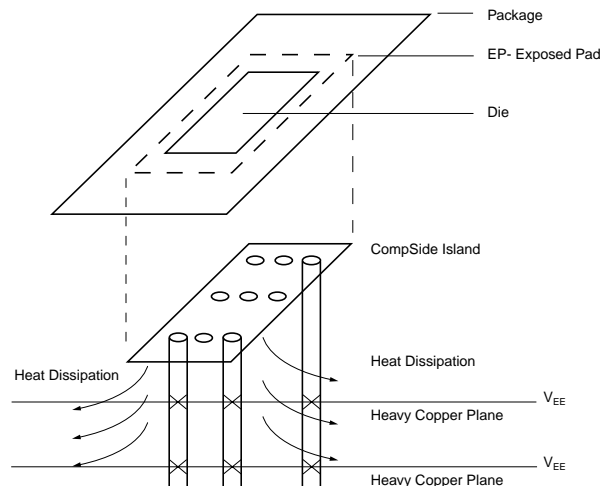

PCB Thermal Consideration for 8-Pin MLF® Package

Package Notes:

1. Package meets Level 2 moisture sensitivity classification, and is shipped in dry-pack form.
2. Exposed pads must be soldered to plane equivalent to device V_{EE} pin's potential for proper thermal management.

MICREL, INC. 2180 FORTUNE DRIVE SAN JOSE, CA 95131 USA

TEL + 1 (408) 944-0800 FAX + 1 (408) 944-0970 WEB <http://www.micrel.com>

The information furnished by Micrel in this datasheet is believed to be accurate and reliable. However, no responsibility is assumed by Micrel for its use. Micrel reserves the right to change circuitry and specifications at any time without notification to the customer.

Micrel Products are not designed or authorized for use as components in life support appliances, devices or systems where malfunction of a product can reasonably be expected to result in personal injury. Life support devices or systems are devices or systems that (a) are intended for surgical implant into the body or (b) support or sustain life, and whose failure to perform can be reasonably expected to result in a significant injury to the user. A Purchaser's use or sale of Micrel Products for use in life support appliances, devices or systems is at Purchaser's own risk and Purchaser agrees to fully indemnify Micrel for any damages resulting from such use or sale.

© 2006 Micrel, Incorporated.