

TRANSITION MODE PFC CONTROLLER

FEATURES

- Transition Mode PFC Controller for Low Implementation Cost
- Industry Pin Compatibility With Improved Feature Set
- Improved Transient Response With Slew-Rate Comparator
- Zero Power Detect to Prevent OVP During Light Load Conditions
- Accurate Internal V_{REF} for Tight Output Regulation
- Two UVLO Options
- Overvoltage Protection (OVP), Open-Feedback Protection and Enable Circuits
- $\pm 750\text{-mA}$ Peak Gate Drive Current
- Low Start-Up and Operating Currents
- Lead (Pb)-Free Packages

APPLICATIONS

- Switch-Mode Power Supplies for Desktops, Monitors, TVs and Set Top Boxes (STBs)
- AC Adapter Front-End Power Supplies
- Electronic Ballasts

DESCRIPTION

The UCC38050 and UCC38051 are PFC controllers for low-to-medium power applications requiring compliance with IEC 1000-3-2 harmonic reduction standard. It is designed for controlling a boost preregulator operating in transition mode (also referred to as boundary conduction mode or critical conduction mode operation). It features a transconductance voltage amplifier for feedback error processing, a simple multiplier for generating a current command proportional to the input voltage, a current-sense (PWM) comparator, PWM logic and a totem-pole driver for driving an external FET.

SIMPLIFIED APPLICATION DIAGRAM

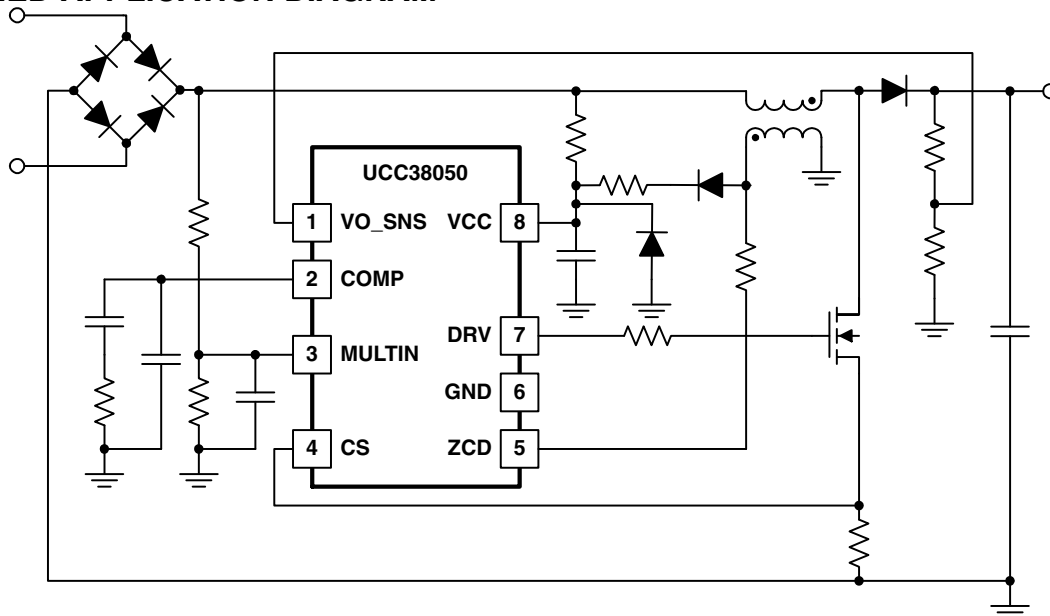

UDG-02125



Please be aware that an important notice concerning availability, standard warranty, and use in critical applications of Texas Instruments semiconductor products and disclaimers thereto appears at the end of this data sheet.

description (continued)

In the transition mode operation, the PWM circuit is self-oscillating with the turn-on being governed by an inductor zero-current detector (ZCD pin) and the turn-off being governed by the current-sense comparator. Additionally, the controller provides features such as peak current limit, default timer, overvoltage protection (OVP) and enable.

The UCC38050 and UCC38051, while being pin compatible with other industry controllers providing similar functionality, offer many feature enhancements and tighter specifications, leading to an overall reduction in system implementation cost. The system performance is enhanced by incorporation of zero power detect function which allows the controller output to shut down at light load conditions without running into overvoltage. The device also features innovative slew rate enhancement circuits which improve the large signal transient performance of the voltage error amplifier. The low start-up and operating currents of the device results in low power consumption and ease of start-up. Highly accurate internal bandgap reference leads to tight regulation of output voltage in normal and OVP conditions, resulting in higher system reliability. The enable comparator ensures that the controller is off if the feedback sense path is broken or if the input voltage is very low.

There are two key parameteric differences between UCC38050 and UCC38051. The UVLO turn-on threshold of UCC38050 is 15.8 V while for UCC38051 it is 12.5 V. Secondly, the g_M amplifier's source current for UCC38050 is typically 1.3 mA while for UCC38051 it is 300 μ A. The higher UVLO turn-on threshold of the UCC38050 allows quicker and easier start-up with a smaller V_{CC} capacitance while the lower UVLO turn-on threshold of UCC38051 allows the operation of the PFC chip to be easily controlled by the downstream PWM controller in two-stage power converters. The UCC38050 g_M amplifier also provides a full 1.3-mA typical source current for faster start-up and improved transient response when output is low either at start-up or during transient conditions. The UCC38051 scales this source current back down to 300- μ A typical source current to gradually increase the error voltage preventing a step increase in line currents at start-up but still provides good transient response. The UCC38051 is suitable for multiple applications including AC adapters where a two-stage power conversion is needed. The UCC38050 is suitable for applications such as electronic ballasts where there is no down-stream PWM conversion and the advantages of smaller V_{CC} capacitor and improved transient response can be realized.

Devices are available in either the industrial temperature range of -40°C to 105°C (UCC2805x) or commercial temperature range of 0°C to 70°C (UCC3805x). Package offerings are 8-pin SOIC (D) or 8-pin PDIP (P) packages.

ORDERING INFORMATION

$T_A = T_J$	UVLO Threshold Voltage ON/OFF (V)	g_M Amplifier Source Current (μ A)	Packaged Devices ⁽¹⁾	
			SOIC-8 (D)	PDIP-8 (P)
-40°C to 105°C	15.8 / 9.7	-1300	UCC28050D	UCC28050P
	12.5 / 9.7	-300	UCC28051D	UCC28051P
0°C to 70°C	15.8 / 9.7	-1300	UCC38050D	UCC38050P
	12.5 / 9.7	-300	UCC38051D	UCC38051P

⁽¹⁾ D (SOIC-8) package is available taped and reeled. Add R suffix to device type (e.g. UCC28050DR) to order quantities of 2,500 devices per reel.

CONNECTION DIAGRAM

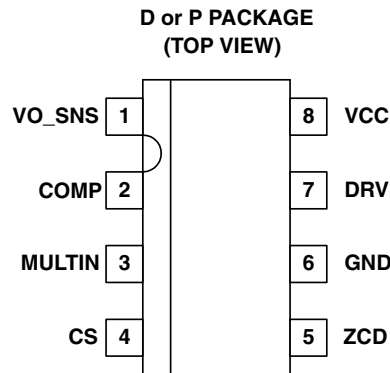

ABSOLUTE MAXIMUM RATINGS

over operating free-air temperature range unless otherwise noted⁽¹⁾

		UCCx805x	UNIT
Supply voltage, V_{CC}	(Internally clamped)	20	V
Input current into V_{CC} clamp	I_{DD}	30	mA
Input current	ZCD	± 10	
Gate drive current (peak), I_{DRV}	DRV	± 750	
Input voltage range, V_{CC}	VO_SNS, MULTIN, CS	5	V
Maximum negative voltage	VO_SNS, MULTIN, DRV, CS	-0.5	
Power dissipation at $T_A = 50^\circ\text{C}$	D package	650	mW
	P package	1	W
Operating junction temperature range, T_J		-55 to 150	°C
Storage temperature, T_{stg}		-65 to 150	
Lead temperature 1,6 mm (1/16 inch) from case for 10 seconds		300	

⁽¹⁾ Stresses beyond those listed under “absolute maximum ratings” may cause permanent damage to the device. These are stress ratings only, and functional operation of the device at these or any other conditions beyond those indicated under “recommended operating conditions” is not implied. Exposure to absolute-maximum-rated conditions for extended periods may affect device reliability. All voltages are with respect to GND. Currents are positive into, negative out of the specified terminal.

THERMAL RATINGS

		SO8 (D)	DIP (P)	UNIT
$R_{\theta JA}$	Max. thermal resistance junction to ambient	150	100	°C/W

UCC28050, UCC28051 UCC38050, UCC38051

SLUS515F–SEPTEMBER 2002 – REVISED MARCH 2009

ELECTRICAL CHARACTERISTICS

$T_A = 0^\circ\text{C}$ to 70°C for the UCC3805x, -40°C to 105°C for the UCC2805x, $T_A = T_J$, $V_{CC} = 12\text{ V}$.

supply

PARAMETER	TEST CONDITIONS	MIN	TYP	MAX	UNITS
V_{CC} operating voltage				18	V
Shunt voltage	$I_{VCC} = 25\text{ mA}$	18	19	20	
Supply current, off	$V_{CC} = V_{CC}$ turn-on threshold -300 mV		75	125	μA
Supply current, disabled	$VO_SNS = 0.5\text{ V}$		2	4	mA
Supply current, on	75 kHz, $C_L = 0\text{ nF}$		4	6	
Supply current, dynamic operating	75 kHz, $C_L = 1\text{ nF}$		5	7	

UVLO

PARAMETER	TEST CONDITIONS	MIN	TYP	MAX	UNITS
V_{CC} turn-on threshold	UCCx8050	15.4	15.8	16.4	V
	UCCx8051	12.0	12.5	13.0	
V_{CC} turn-off threshold		9.4	9.7	10.0	
UVLO hysteresis	UCCx8050	5.8	6.3	6.8	
	UCCx8051	2.3	2.8	3.3	

voltage amplifier (VO_SNS)

PARAMETER	TEST CONDITIONS	MIN	TYP	MAX	UNITS
Input voltage (V_{REF})	UCC3805x	2.46	2.50	2.54	V
	UCC2805x	2.45	2.50	2.55	
Input bias current				0.5	μA
V_{COMP} high	$VO_SNS = 2.1\text{ V}$	4.5		5.5	V
V_{COMP} low	$VO_SNS = 2.55\text{ V}$		1.80	2.45	
g_M	$T_J = 25^\circ\text{C}$, $V_{COMP} = 3.5\text{ V}$	60	90	130	μS
Source current	UCCx8050	$VO_SNS = 2.1\text{ V}$, $V_{COMP} = 3.5\text{ V}$	-0.2	-1.0	mA
	UCCx8051	$VO_SNS = 2.1\text{ V}$, $V_{COMP} = 2.5\text{ V}$	-200	-300	
Sink current	$VO_SNS = 2.7\text{ V}$, $V_{COMP} = 3.5\text{ V}$	0.2	1.0		μA

over voltage protection / enable

PARAMETER	TEST CONDITIONS	MIN	TYP	MAX	UNITS
Overvoltage reference	UCCx8050	$V_{REF} + 0.165$	$V_{REF} + 0.190$	$V_{REF} + 0.210$	V
	UCCx8051	$V_{REF} + 0.150$	$V_{REF} + 0.180$	$V_{REF} + 0.210$	
Hysteresis	UCCx8050	175	200	225	mV
	UCCx8051	150	180	210	
Enable threshold	UCCx8050	0.62	0.67	0.72	V
	UCCx8051	0.18	0.23	0.28	
Enable hysteresis		0.05	0.10	0.20	V

multiplier

PARAMETER	TEST CONDITIONS	MIN	TYP	MAX	UNITS
Multiplier gain constant (k)	$V_{MULTIN} = 0.5\text{ V}$, $COMP = 3.5\text{ V}$	0.43	0.65	0.87	1/V
Dynamic input range, V_{MULTIN} INPUT		0 to 2.5	0 to 3.5		V
Dynamic input range, COMP INPUT		2.5 to 3.8	2.5 to 4.0		V
Input bias current, MULTIN			0.1	1.0	μA

ELECTRICAL CHARACTERISTICS

$T_A = 0^\circ\text{C}$ to 70°C for the UCC3805x, -40°C to 105°C for the UCC2805x, $T_A = T_J$, $V_{CC} = 12\text{ V}$.

zero power

PARAMETER	TEST CONDITIONS	MIN	TYP	MAX	UNITS
Zero power comparator threshold ⁽¹⁾	Measured on V_{COMP}	2.1	2.3	2.5	V

zero current detect

PARAMETER	TEST CONDITIONS	MIN	TYP	MAX	UNITS
Input threshold (rising edge) ⁽¹⁾		1.5	1.7	2.0	V
Hysteresis ⁽¹⁾		250	350	450	mV
Input high clamp	$I = 3\text{ mA}$		5	6	V
Input low clamp	$I = -3\text{ mA}$	0.30	0.65	0.90	V
Restart time delay		200	400		μs

current sense comparator

PARAMETER	TEST CONDITIONS	MIN	TYP	MAX	UNITS
Input bias current	$CS = 0\text{ V}$		0.1	1.0	μA
Input offset voltage ⁽¹⁾		-10		10	mV
Delay to output	CS to DRV		300	450	ns
Maximum current sense threshold voltage		1.55	1.70	1.80	V

PFC gate driver

PARAMETER	TEST CONDITIONS	MIN	TYP	MAX	UNITS
GT1 pull up resistance	$I_{OUT} = -125\text{ mA}$		5	12	Ω
GT1 pull down resistance	$I_{OUT} = 125\text{ mA}$		2	10	Ω
GT1 output rise time	$C_{LOAD} = 1\text{ nF}$, $R_{LOAD} = 10\ \Omega$		25	75	ns
GT1 output fall time	$C_{LOAD} = 1\text{ nF}$, $R_{LOAD} = 10\ \Omega$		10	50	ns

(1) Ensured by design. Not production tested.

BLOCK DIAGRAM

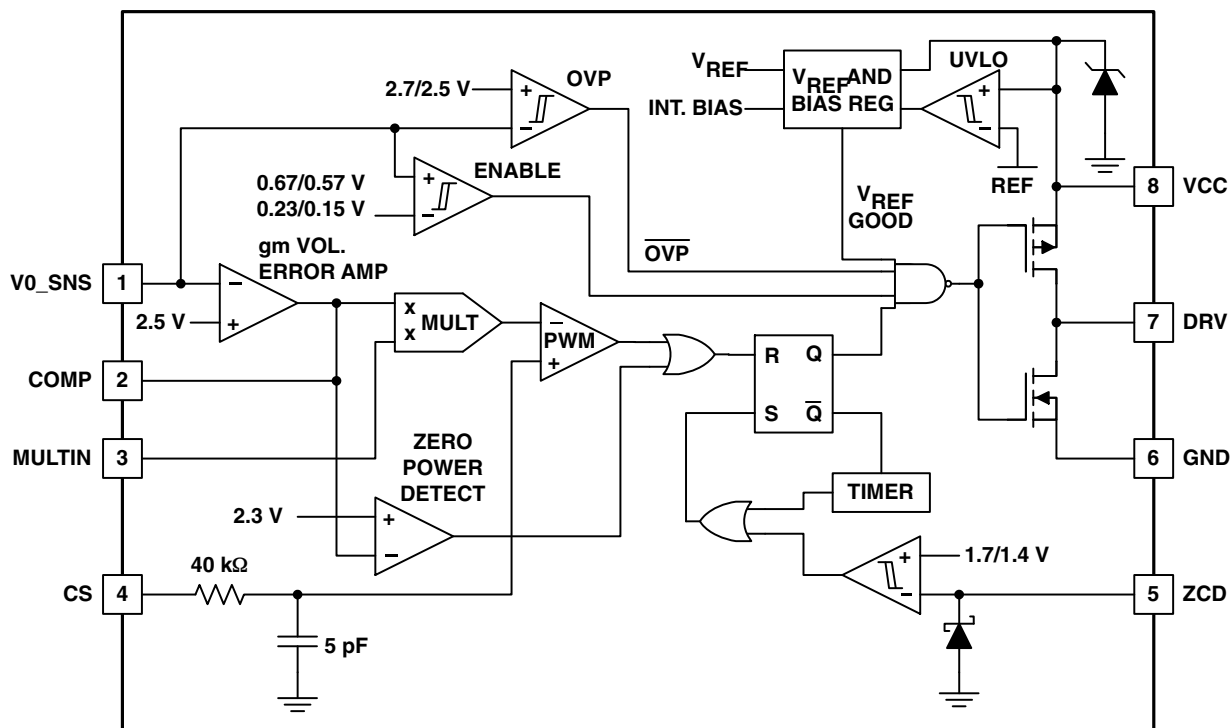

UDG-02008

PIN DESCRIPTIONS

VO_SNS (Pin 1): This pin senses the boost regulator output voltage through a voltage divider. Internally, this pin is the inverting input to the transconductance amplifier (with a nominal value of 2.5 V) and also is input to the OVP comparator. Additionally, pulling this pin below the ENABLE threshold turns off the output switching, ensuring that the gate drive is held off while the boost output is pre-charging and also ensuring no runaway if feedback path is open.

COMP (Pin 2): Output of the transconductance error amplifier. Loop compensation components are connected between this pin and ground. The output current capability of this pin is 10- μ A under normal conditions, but increases to about 1-mA when the differential input is greater than the specified values in the specifications table. This voltage is one of the inputs to the multiplier, with a dynamic input range of 2.5 V to 3.8 V. During zero power or overvoltage conditions, this pin goes below 2.5 V nominal. When it goes below 2.3 V, the zero power comparator is activated which prevents the gate drive from switching.

MULTIN (Pin 3): This pin senses the instantaneous boost regulator input voltage through a voltage divider. The voltage acts as one of the inputs to the internal multiplier. Recommended operating range is 0 V to 2.5 V at high line.

PIN DESCRIPTIONS (continued)

CS (Pin 4): This pin senses the instantaneous switch current in the boost switch and uses it as the internal ramp for PWM comparator. The internal circuitry filters out switching noise spikes without requiring external components. In addition, an external R-C filter may be required to suppress the noise spikes. An internal clamp on the multiplier output terminates the switching cycle if this pin voltage exceeds 1.7 V. Additional external filtering may be required. CS threshold is approximately equal to:

$$V_{CS} \cong 0.67 (\text{COMP} - 2.5 \text{ V}) (\text{MULTIN} + V_{\text{OFFSET}})$$

V_{OFFSET} is approximately 75 mV to improve the zero crossing distortion.

ZCD (Pin 5): This pin is the input for the zero current detect comparator. The boost inductor current is indirectly sensed through the bias winding on the boost inductor. The ZCD pin input goes low when the inductor current reaches zero and that transition is detected. Internal active voltage clamps are provided to prevent this pin from going below ground or too high. If zero current is not detected within 400 μs , a reset timer sets the latch and gate drive.

GND (Pin 6): The chip reference ground. All bypassing elements are connected to ground pin with shortest loops feasible.

DRV (Pin 7): The gate drive output for an external boost switch. This output is capable of delivering up to 750-mA peak currents during turn-on and turn-off. An external gate drive resistor may be needed to limit the peak current depending on the V_{CC} voltage being used. Below the UVLO threshold, the output is held low.

VCC (Pin 8): The supply voltage for the chip. This pin should be bypassed with a high-frequency capacitor (greater than 0.1- μF) and tied to GND. The UCC38050 has a wide UVLO hysteresis of approximately 6.3 V that allows use of lower value supply capacitor on this pin for quicker and easier start-up. The UCC38051 has a narrow UVLO hysteresis with of about 2.8 V and a start-up voltage of about 12.5 V for applications where the operation of the PFC device needs to be controlled by a downstream PWM controller.

BLOCK DESCRIPTION

UVLO and Reference Block

This block generates a precision reference voltage used to obtain tightly controlled UVLO threshold. In addition to generating a 2.5-V reference for the non-inverting terminal of the g_M amplifier, it generates the reference voltages for blocks such as OVP, enable, zero power and multiplier. An internal rail of 7.5 V is also generated to drive all the internal blocks.

Error Amplifier

The voltage error amplifier in UCC3805x is a transconductance amplifier with a typical transconductance value of 90 μS . The advantage in using a transconductance amplifier is that the inverting input of the amplifier is solely determined by the external resistive-divider from the output voltage and not the transient behavior of the amplifier itself. This allows the VO_SNS pin to be used for sensing over voltage conditions.

The sink and source capability of the error amplifier is approximately 10 μA during normal operation of the amplifier. But when the VO_SNS pin voltage is beyond the normal operating conditions ($\text{VO_SNS} > 1.05 \times V_{\text{REF}}$, $\text{VO_SNS} < 0.88 \times V_{\text{REF}}$), additional circuitry to enhance the slew-rate of the amplifier is activated. Enhanced slew-rate of the compensation capacitor results in a faster start-up and transient response. This prevents the output voltage from drifting too high or too low, which can happen if the compensation capacitor were to be slewed by the normal slewing current of 10- μA . When VO_SNS rises above the normal range, the enhanced sink current capability is in excess of 1 mA. When VO_SNS falls below the normal range, the UCC38050 can source more than 1 mA and the UCC38051 sources approximately 300 μA . The limited source current in the UCC38051 helps to gradually increase the error voltage on the COMP pin preventing a step increase in line current. The actual rate of increase of V_{COMP} depends on the compensation network connected to the COMP pin.

Zero Current Detection and Re-Start Timer Blocks

When the boost inductor current becomes zero, the voltage at the power MOSFET drain end falls. This is indirectly sensed with a secondary winding that is connected to the ZCD pin. The internal active clamp circuitry prevents the voltage from going to a negative or a high positive value. The clamp has the sink and source capability of 10 mA. The resistor value in series with the secondary winding should be chosen to limit the ZCD current to less than 10 mA. The rising edge threshold of the ZCD comparator can be as high as 2.0 V. The auxiliary winding should be chosen such that the positive voltage (when the power MOSFET is off) at the ZCD pin is in excess of 2.0 V.

The restart timer attempts to set the gate drive high in case the gate drive remains off for more than 400 μs nominally. The minimum guaranteed time period of the timer is 200 μs . This translates to a minimum switching frequency of 5 kHz. In other words, the boost inductor value should be chosen for switching frequencies greater than 5 kHz.

Enable Block

The gate drive signal is held low if the voltage at the VO_SNS pin is less than the ENABLE threshold. This feature can be used to disable the converter by pulling VO_SNS low. If the output feedback path is broken, VO_SNS is pulled to ground and the output is disabled to protect the power stage.

BLOCK DESCRIPTION (continued)

Zero Power Block

When the output of the g_M amplifier goes below 2.3 V, the zero power comparator latches the gate drive signal low. The slew rate enhancement circuitry of the g_M amplifier that is activated during overvoltage conditions slews the COMP pin to about 2.4 V. This ensures that the zero power comparator is not activated during transient behavior (when the slew rate enhancement circuitry is enhanced).

Multiplier Block

The multiplier block has two inputs. One is the error amplifier output voltage (V_{COMP}), while the other is V_{MULTIN} which is obtained by a resistive divider from the rectified line. The multiplier output is approximately $0.67 \times V_{MULTIN} \times (V_{COMP} - 2.5 \text{ V})$. There is a positive offset of about 75 mV to the V_{MULTIN} signal because this improves the zero-crossing distortion and hence the THD performance of the controller in the application. The dynamic range of the inputs can be found in the electrical characteristics table.

Overvoltage Protection (OVP) Block

The OVP feature in the part is not activated under most operating conditions because of the presence of the slew rate enhancement circuitry present in the error amplifier. As soon as the output voltage reaches to about 5% to 7% above the nominal value, the slew rate enhancement circuit is activated and the error amplifier output voltage is pulled below the dynamic range of the multiplier block. This prevents further rise in output voltage.

If the COMP pin is not pulled low fast enough, and the voltage rises further, the OVP circuit acts as a second line of protection. When the voltage at the VO_SNS pin is more than 7.5% of the nominal value ($>(V_{REF} + 0.190)$), the OVP feature is activated. It stops the gate drive from switching as long as the voltage at the VO_SNS pin is above the nominal value (V_{REF}). This prevents the output dc voltage from going above 7.5% of the nominal value designed for, and protects the switch and other components of the system like the boost capacitor.

Transition Mode Control

The boost converter, the most common topology used for power factor correction, can operate in two modes – continuous conduction mode (CCM) and discontinuous conduction mode (DCM). Transition mode control, also referred to as critical conduction mode (CRM) or boundary conduction mode, maintains the converter at the boundary between CCM and DCM by adjusting the switching frequency.

The CRM converter typically uses a variation of hysteretic control with the lower boundary equal to zero current. It is a variable frequency control technique that has inherently stable input current control while eliminating reverse recovery rectifier losses. As shown in Figure 1, the switch current is compared to the reference signal (output of the multiplier) directly. This control method has the advantage of simple implementation and still can provide very good power factor correction.

UCC28050, UCC28051 UCC38050, UCC38051

SLUS515F-SEPTEMBER 2002 - REVISED MARCH 2009

TYPICAL APPLICATION DIAGRAM

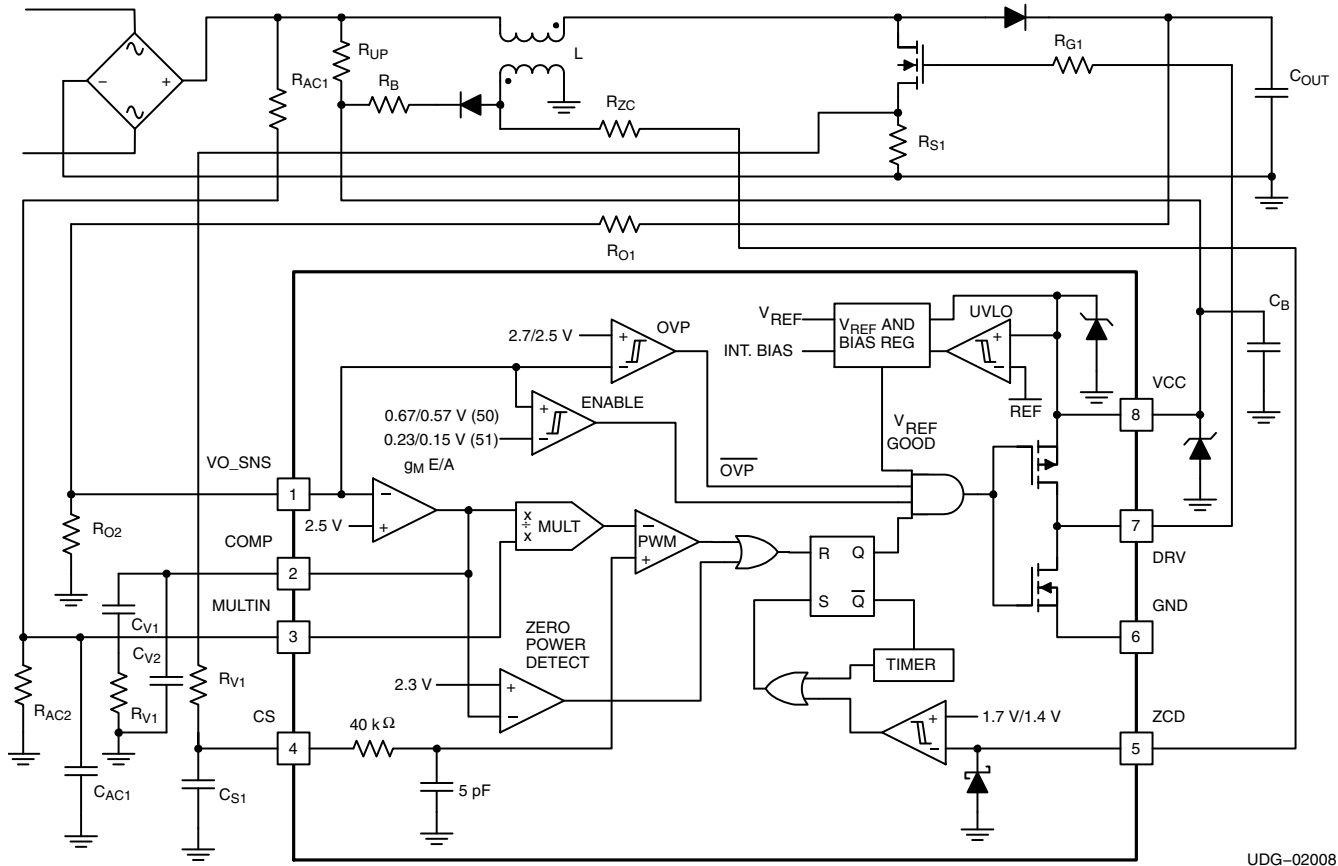

APPLICATION INFORMATION

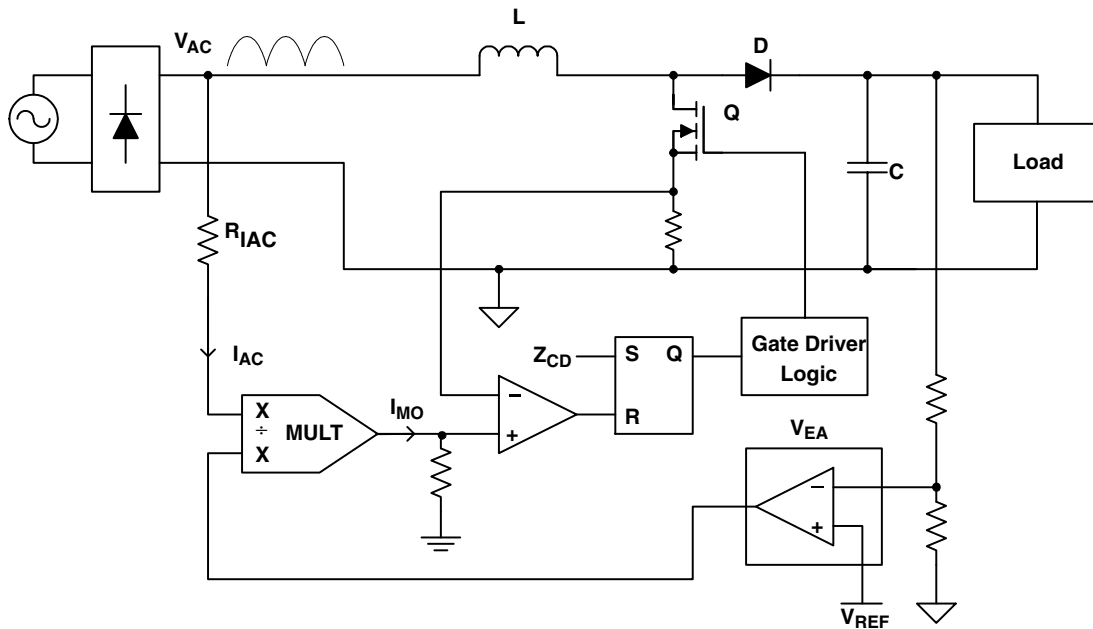

UDG-02124

Figure 1. Basic Block Diagram of CRM Boost PFC

The power stage equations and the transfer functions of the CRM are the same as the CCM. However, implementations of the control functions are different. Transition mode forces the inductor current to operate just at the border of CCM and DCM. The current profile is also different and affects the component power loss and filtering requirements. The peak current in the CRM boost is twice the amplitude of CCM leading to higher conduction losses. The peak-to-peak ripple is twice the average current which affects MOSFET switching losses and magnetics ac losses.

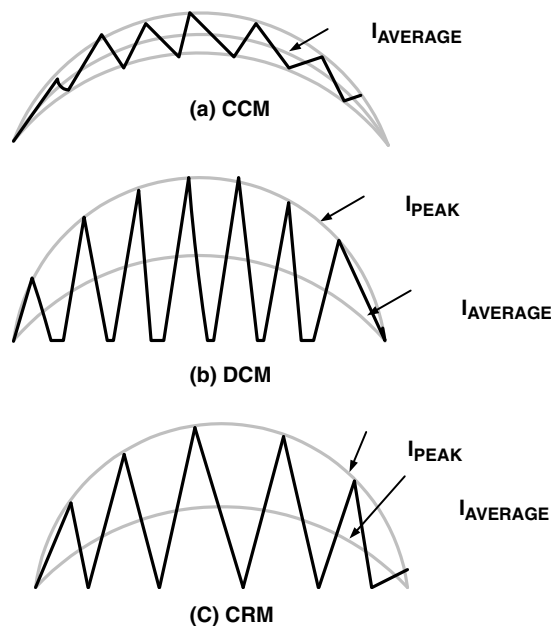

Note: Operating Frequency >> 120 Hz

UDG-02123

Figure 2. PFC Inductor Current Profiles

APPLICATION INFORMATION

For low to medium power applications up to approximately 300 W, the CRM boost has an advantage in losses. The filtering requirement is not severe and therefore is not a disadvantage. For medium to higher power applications, where the input filter requirements dominate the size of the magnetics, the CCM boost is a better choice due to lower peak currents (which reduces conduction losses) and lower ripple current (which reduces filter requirements). The main tradeoff in using CRM boost is lower losses due to no reverse recovery in the boost diode vs. higher ripple and peak currents.

Design Procedure

For a selected V_{OUT} and minimum switching frequency, the following equations outline the design guidelines for power stage component selection. Refer to the typical application diagram for reference designers.

Inductor Selection

In the transition mode control, the inductor value needs to be calculated to start the next switching cycle at zero current. The time it takes to reach zero depends on line voltage and inductance and as shown in equation (1), L determines the converter's frequency range.

$$L = \frac{\left(V_{AC(min)}\right)^2 \times \left(V_{OUT} - \sqrt{2} \times V_{AC(min)}\right)}{2 \times F_{s(min)} \times V_{OUT} \times P_{IN}} \quad (1)$$

where

- V_{AC} = RMS line voltage
- $V_{AC(min)}$ = minimum AC line voltage
- P_{IN} = maximum input power averaged over the ac line period

$$I_{L(peak)} = 2 \times \sqrt{2} \times \frac{P_{IN}}{V_{AC(min)}} \quad (2)$$

$$I_{L(rms)} = \frac{I_{L(peak)}}{\sqrt{6}} \quad (3)$$

MOSFET Selection

The main switch selection is driven by the amount of power dissipation allowable. It is important to choose a device that minimizes gate charge and capacitance and minimizes the sum of switching and conduction losses at a given frequency.

$$I_{Q(rms_crm)} = \sqrt{\frac{1}{6} - (4 \times \sqrt{2}) \times \left(\frac{V_{AC(min)}}{9\pi \times V_{OUT}}\right)} \times I_{L(peak_crm)} \quad (4)$$

$$V_{Q(max)} = V_{OUT} \quad (5)$$

APPLICATION INFORMATION

Diode Selection

The effects of the reverse recovery current in the diode can be eliminated with relatively little negative impact to the system. The diode selection is based on reverse voltage, forward current, and switching speed.

$$I_{D(\text{avg})} = I_{\text{OUT}(\text{avg})} \quad (6)$$

$$I_{D(\text{rms})} = I_{L(\text{peak})} \sqrt{\frac{\sqrt{2} \times V_{\text{AC}}}{\pi \times V_{\text{OUT}}}} \quad (7)$$

$$V_{D(\text{peak})} = V_{\text{OUT}} \quad (8)$$

Capacitor Selection

The hold-up time is the main requirement in determining the output capacitance. ESR and the maximum RMS ripple current rating may also be important especially at higher power levels.

$$C_{\text{OUT}(\text{min})} = \frac{(2 \times P_{\text{OUT}} \times t_{\text{HOLDUP}})}{\left((V_{\text{OUT}})^2 - (V_{\text{OUT}(\text{min})})^2 \right)} \quad (9)$$

where:

- $V_{\text{OUT}(\text{min})}$ = minimum regulator input voltage for operation

$$I_{C(\text{rms})} = \sqrt{\left(I_{L(\text{peak})} \right)^2 \times \frac{\sqrt{2} \times V_{\text{AC}(\text{max})}}{\pi \times V_{\text{OUT}}} - \left(\frac{P_{\text{OUT}}}{V_{\text{OUT}}} \right)^2 + (\text{ac rms load currents})^2} \quad (10)$$

Multiplier Set-Up

Select $R_{\text{AC}1}$ and $R_{\text{AC}2}$ so that their ratio uses the full dynamic range of the multiplier input at the peak line voltage yet, their values are small enough to make the effects of the multiplier bias current negligible. In order to use the maximum range of the multiplier, select the divider ratio so that V_{MULTIN} evaluated at the peak of the maximum ac line voltage is the maximum of the minimum dynamic input range of MULTIN, which is 2.5 V. Choose $R_{\text{AC}1}$ so that it has at least 100- μA at the peak of the minimum ac operating line voltage.

$$\frac{R_{\text{AC}1}}{R_{\text{AC}2}} = \left(\frac{\sqrt{2}}{2.5} V_{\text{AC}(\text{max})} \right) - 1 \quad (11)$$

In extreme cases, switching transients can contaminate the MULTIN signal and it can be beneficial to add capacitor $C_{\text{AC}1}$. Select the value of $C_{\text{AC}1}$ so that the corner frequency of the resulting filter is greater than the lowest switching frequency. Keep in mind that the low corner frequency of this filter may compromise the overall power factor.

APPLICATION INFORMATION

Sense Resistor Selection

The current sense resistor value must be chosen to limit the output power and it must also use the full dynamic range of the multiplier during normal steady state operation. The value of R_{S1} is thus selected for maximum power operation at low ac line voltage conditions. In order to use the full dynamic range, set the V_{SENSE} threshold as a function of the dynamic input range of V_{COMP} and the peak of the minimum MULTIN voltage.

$$R_{S1} = \frac{0.67 \times (COMP_{(MAX)} - COMP_{(MIN)}) \times (MULTIN_{(PEAK)@VAC(min)} - 0.075)}{2 \times \sqrt{2} \times \frac{P_{IN(max)}}{V_{AC(min)}}} \quad (12)$$

where:

- $COMP_{(MAX)} = 3.8 \text{ V}$
- $COMP_{(MIN)} = 2.5 \text{ V}$
- $MULTIN_{(PEAK)@VAC(min)} = \sqrt{2} \times V_{AC(min)} \left(\frac{R_{AC2}}{R_{AC2} + R_{AC1}} \right)$

If the exact value R_{S1} is not available. R_{S2} and R_{S3} can be added for further scaling. The CS pin already has an internal filter for noise due to switching transients. Additional filtering at switching transient frequencies can be achieved by adding C_{S1} .

Output Voltage Sense Design

Select the divider ratio of R_{O1} and R_{O2} to set the VO_SNS voltage to 2.5 V at the desired output voltage. The current through the divider should be at least 200 μA .

Voltage Loop Design

How well the voltage control loop is designed directly impacts line current distortion. UCC38050 employs a transconductance amplifier (g_M amp) with gain scheduling for improved transient response (refer to Figure 14. *g_M Amplifier Output Current vs. Current Sense Voltage*). Integral type control at low frequencies is preferred here because the loop gain varies considerably with line conditions. The largest gain occurs at maximum line voltage. If the power factor corrector load is dc-to-dc switching converter, the small signal model of the controller and the power factor corrector, from COMP to PFC output voltage is given by:

$$\frac{\hat{V}_{OUT}(s)}{\hat{V}_{COMP}(s)} = \frac{k_1 \times (V_{AC})^2}{V_{OUT(avg)} \times R_{S1} \times k_{CRM} \times C_{OUT}} \times \frac{1}{s} \quad (13)$$

where:

- \hat{V}_{OUT} = small signal variations in V_{OUT}
- \hat{V}_{COMP} = small signal variations in V_{COMP}
- k_1 = multiplier gain = 0.65
- k_{CRM} = peak to average factor = 2

APPLICATION INFORMATION

A controller that has integral control at low frequencies requires a zero near the crossover frequency in order to be stable. The resulting g_M amplifier configuration is shown in Figure 3.

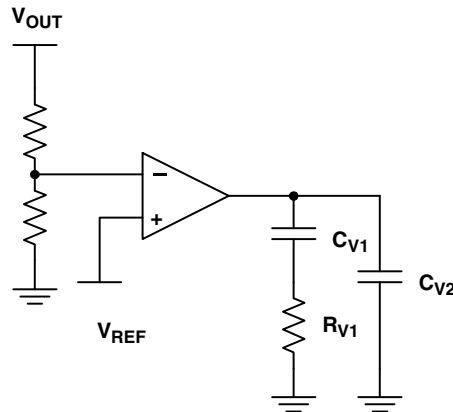

UDG-02122

Figure 3. g_M Amplifier Configuration

The compensator transfer function is:

$$A_V = \frac{g_M}{C_{V1} + C_{V2}} \times \frac{1 + (R_{V1} \times C_{V1} \times s)}{s \left(1 + \left(R_{V1} \times \frac{[C_{V1} \times C_{V2}]}{[C_{V1} + C_{V2}]} \right) \times s \right)} \quad (14)$$

where g_M = dc transconductance gain = 100 μ s

The limiting factor of the gain is usually the allowable third harmonic distortion, though other harmonics can dominate. The crossover frequency of the control loop will be much lower than twice the ac line voltage. In order to choose the compensator dynamics, determine the maximum allowable loop gain at twice the line frequency and solve for capacitor C_{V2} . This also determines the crossover frequency.

$$C_{V2} = \left(\frac{V_{AC(max)}}{4\pi f_{AC}} \right)^2 \times \left(\frac{g_M \times k_1}{V_{OUT(avg)} \times R_{S1} \times k_{(cmr)} \times C_{OUT(max \text{ loop gain @ } 2 f_{AC})}} \right) \quad (15)$$

$$f_{CO} = \frac{V_{AC}}{\pi} \sqrt{\frac{g_M \times k_1}{C_{V2} \times V_{OUT} \times R_{S1} \times k_{(cmr)} \times C_{OUT}}} \quad (16)$$

Select C_{V1} so that the low frequency zero is one-tenth of the crossover frequency.

$$C_{V1} = 9 C_{V2} \quad (17)$$

Select R_{V1} so that the pole is at the crossover frequency.

$$\approx \frac{1}{2 \pi f_{CO} C_{V2}} \quad (18)$$

Bias Current

The bias voltage is supplied by a bias winding on the inductor. Select the turns ratio so that sufficient bias voltage can be achieved at low ac line voltage. The bias capacitor must be large enough to maintain sufficient voltage with ac line variations. Be sure to connect a 0.1- μ F bypass capacitor between the VCC pin and the GND pin as close to the integrated circuit as possible. For wide line variations, a resistor, R_B , is necessary in order to permit clamping action. The bias voltage should also be clamped with an external zener diode to a maximum of 18 V.

Zero Current Detection

The zero current detection activates when the ZCD voltage falls below 1.4 V. The bias winding can provide the necessary voltage. This pin has a clamp at approximately 5 V. Add a current limiting resistor, R_{ZC} , to keep the maximum current below 1 mA.

REFERENCE DESIGN

A reference design is discussed in *100-W Universal Line Input PFC Boost Converter Using the UCC38050*, TI Literature No. SLUU134. The UCC38050 is used for the off-line power factor corrected pre-regulator with operation over a universal input range of 85 V to 265 V with a 400 Vdc regulated output. The schematic is shown in Figure 4 and the board layout for the reference design is shown in Figure 5. Refer to the document for further details.

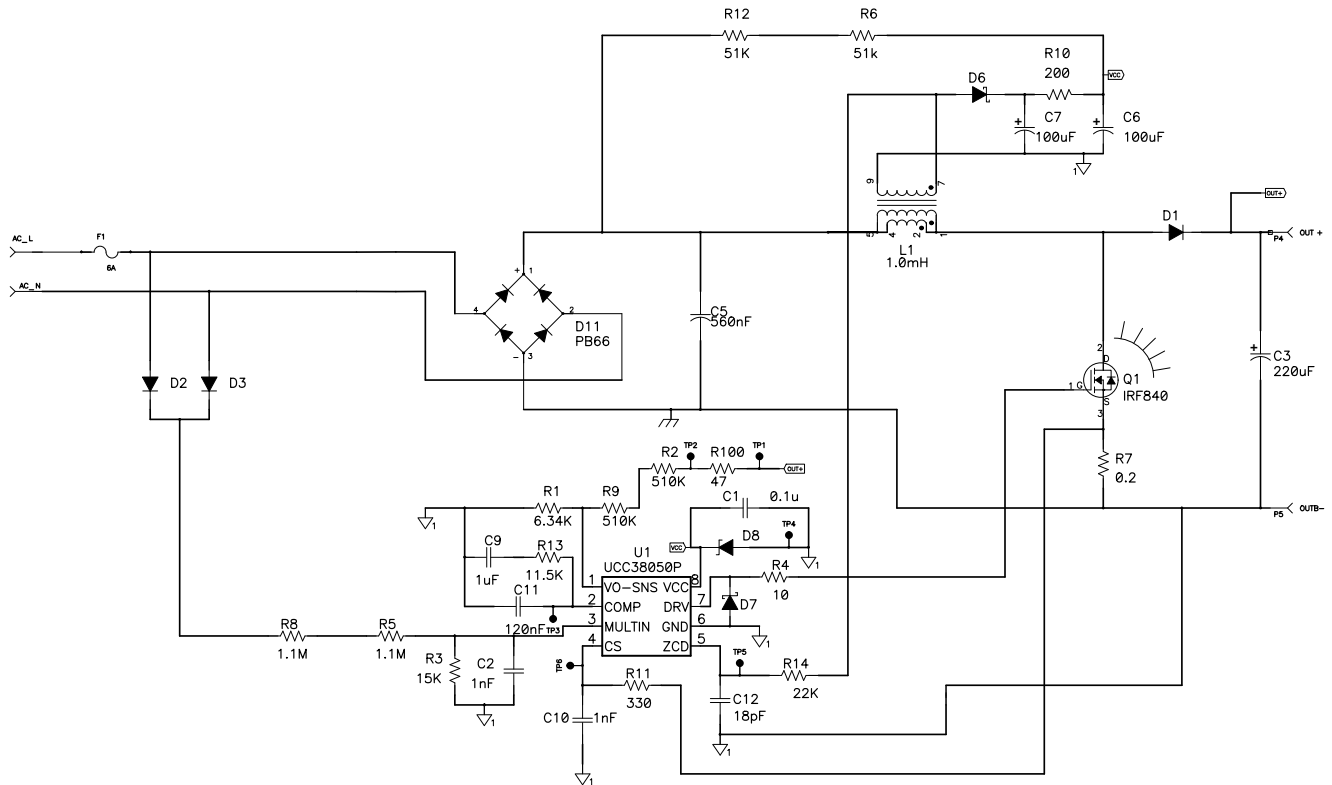

Figure 4. Universal Line Input 100-W Boost Converter Reference Design Schematic

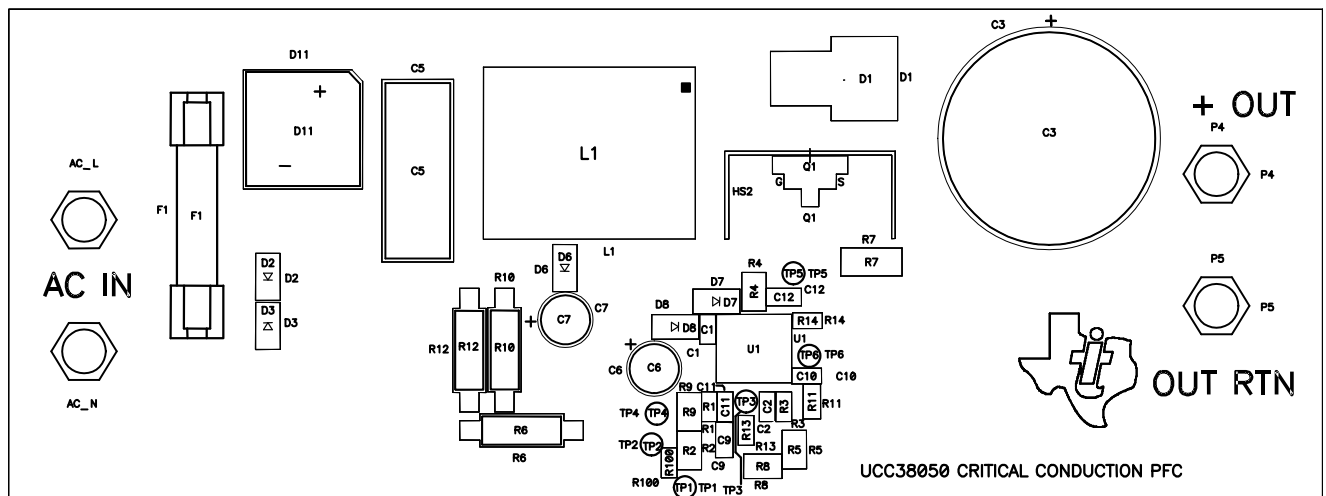

Figure 5. Reference Design Board Layout

TYPICAL CHARACTERISTICS

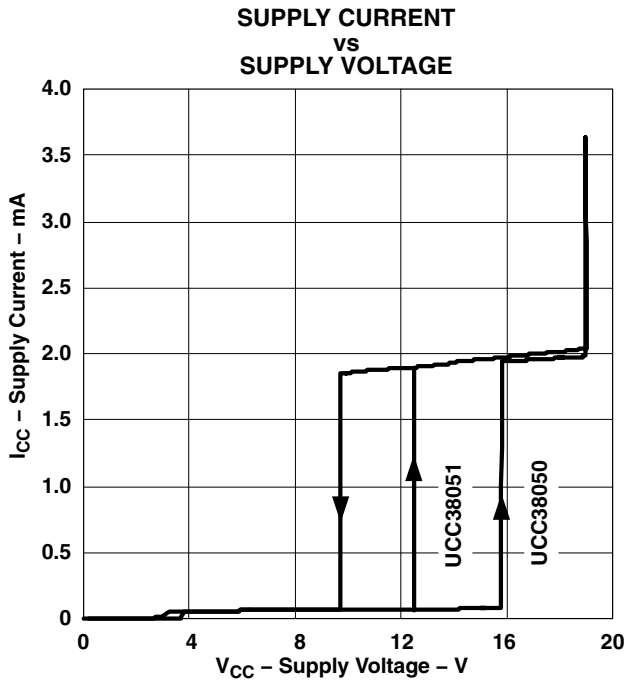

Figure 6

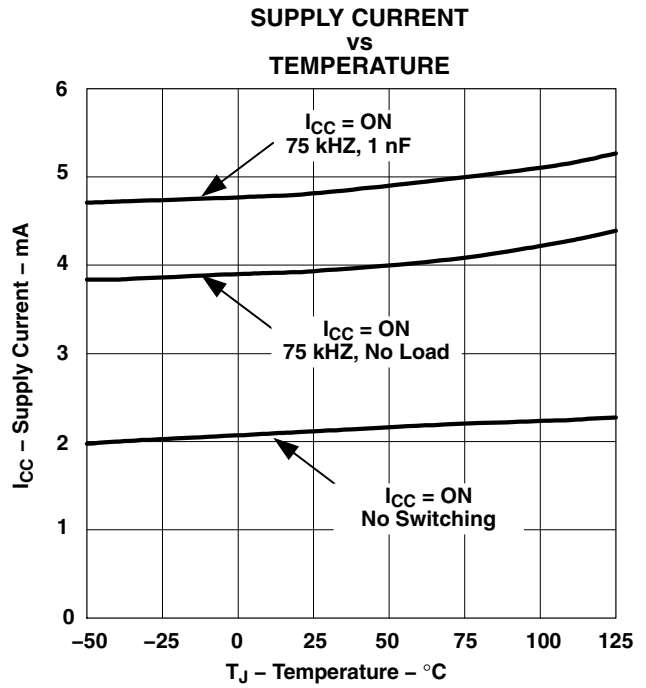

Figure 7

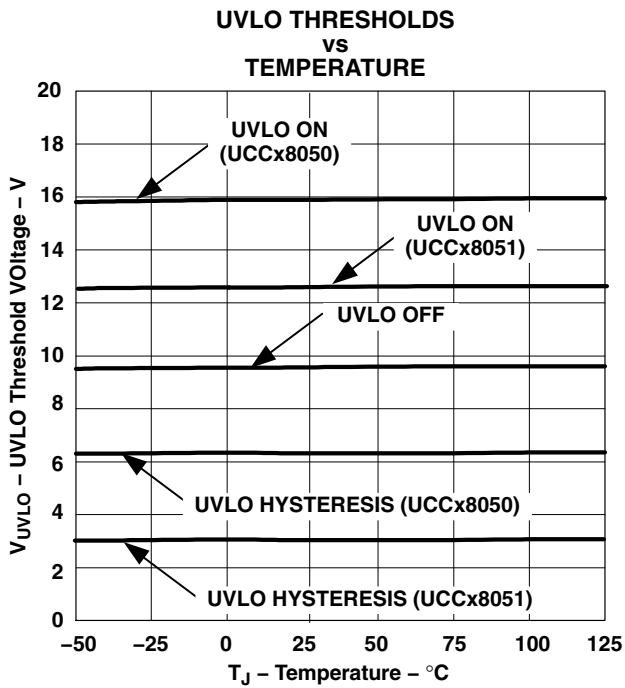

Figure 8

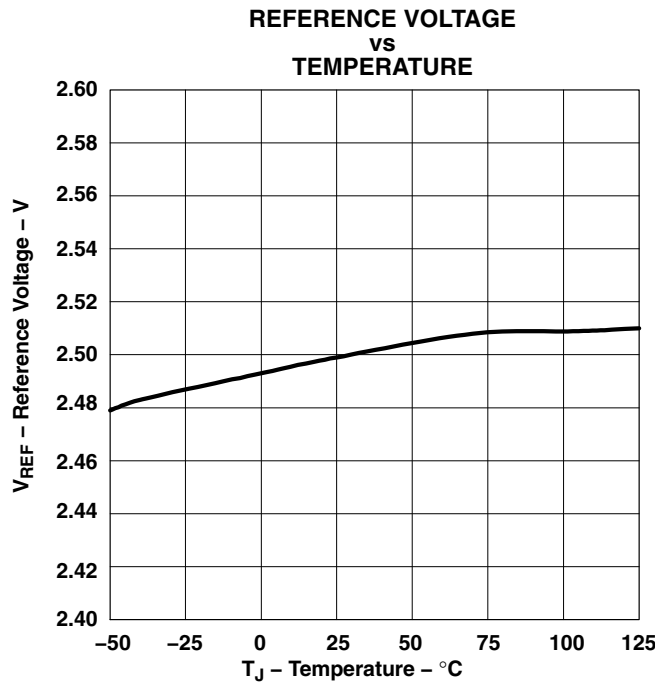

Figure 9

TYPICAL CHARACTERISTICS

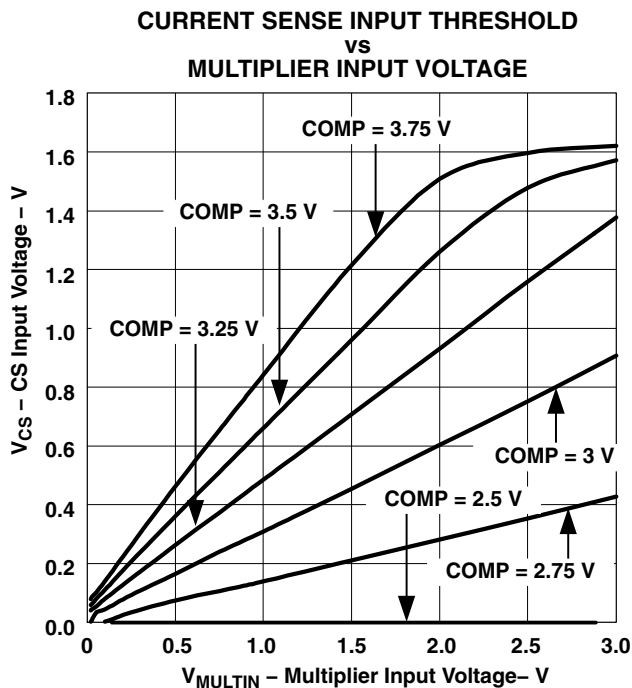

Figure 10

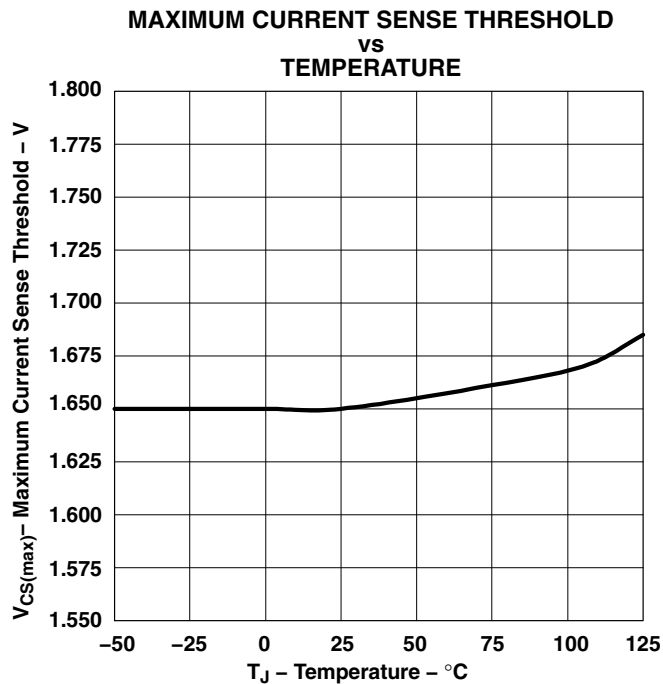

Figure 11

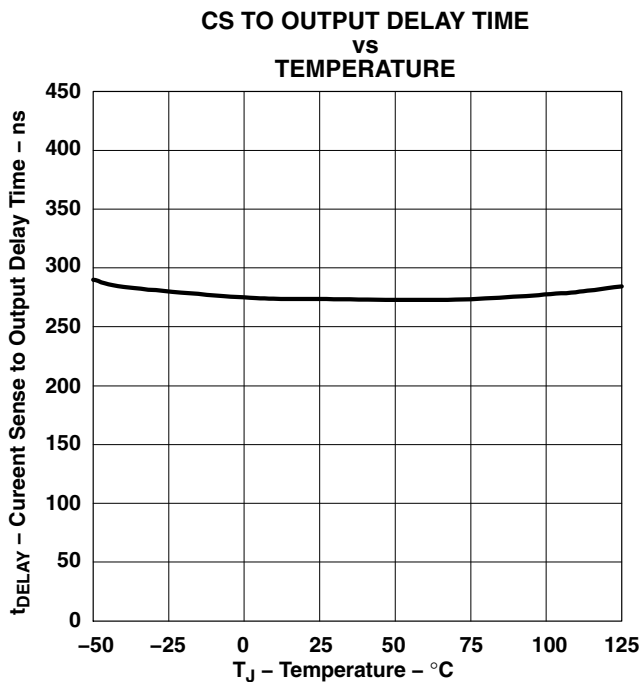

Figure 12

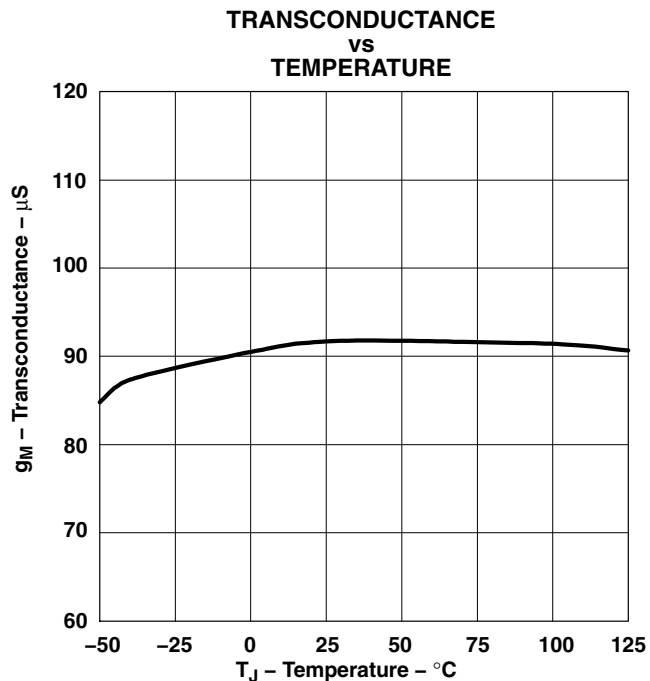

Figure 13

TYPICAL CHARACTERISTICS

**g_M AMPLIFIER OUTPUT CURRENT
 vs
 OUTPUT SENSE VOLTAGE**

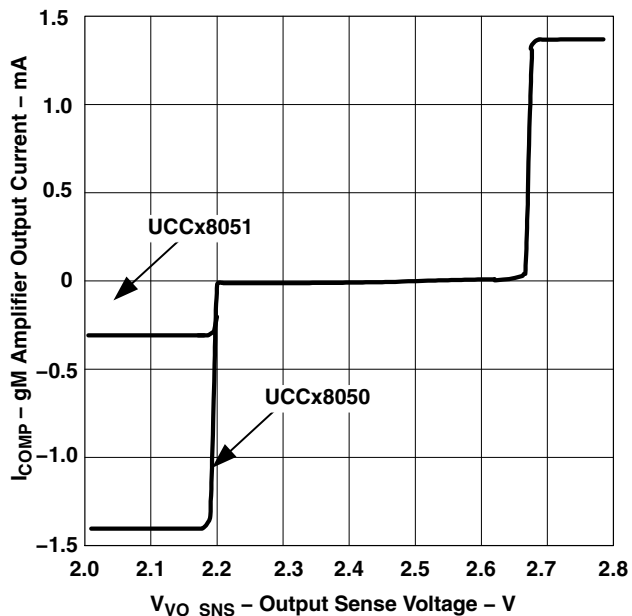

Figure 14

**g_M AMPLIFIER OUTPUT CURRENT
 vs
 OUTPUT SENSE VOLTAGE
 (SMALL SIGNAL VIEW)**

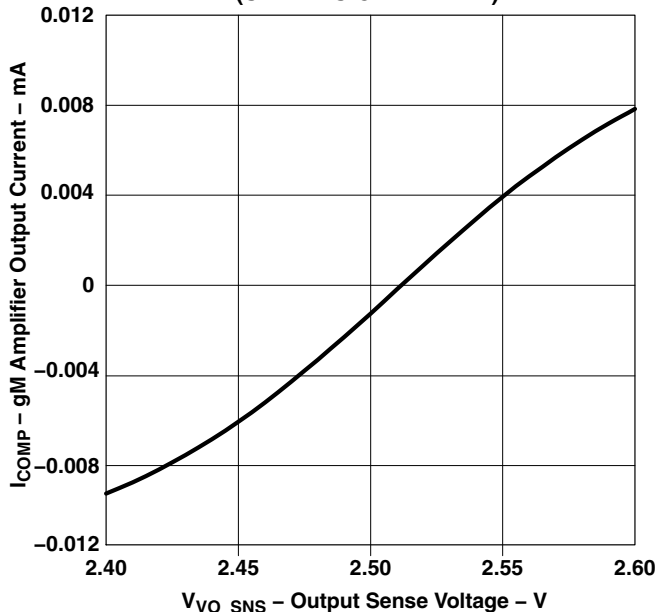

Figure 15

**VOLTAGE AMPLIFIER OUTPUT
 vs
 TIME (UCC38050)**

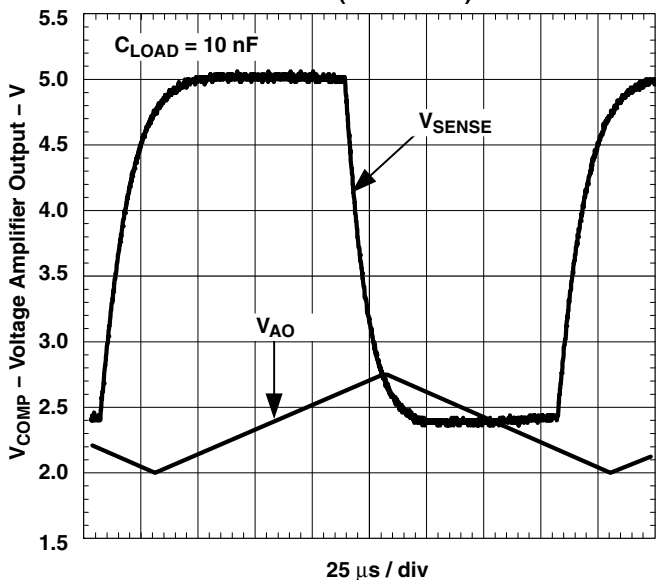

Figure 16

**OVERVOLTAGE PROTECTION THRESHOLDS
 vs
 TEMPERATURE**

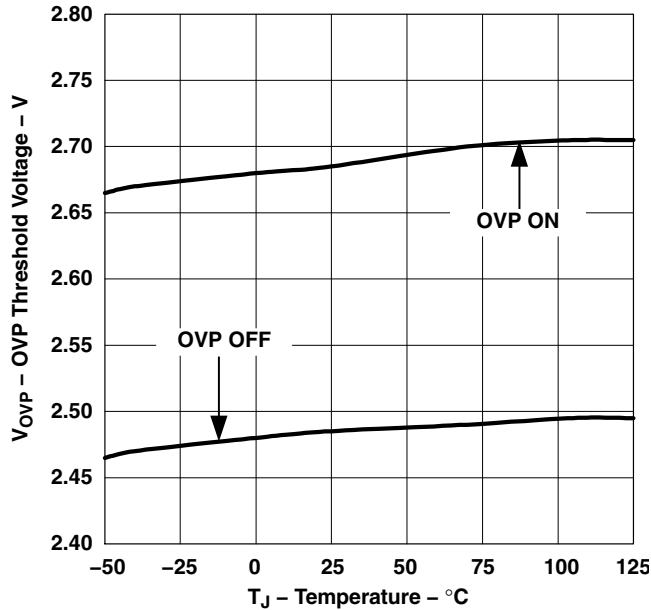

Figure 17

TYPICAL CHARACTERISTICS

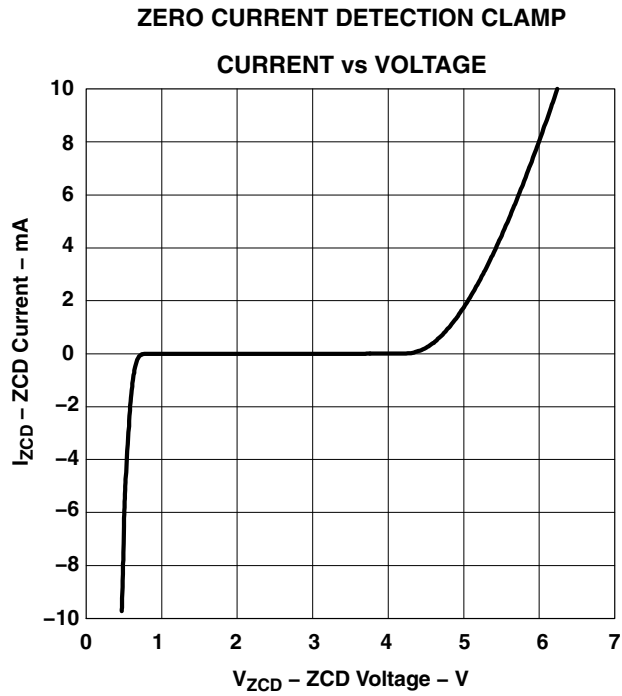

Figure 18

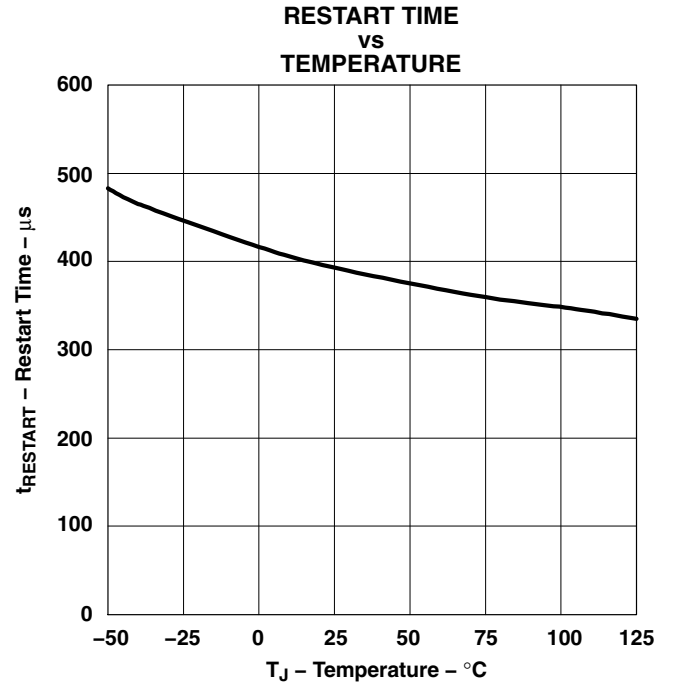

Figure 19

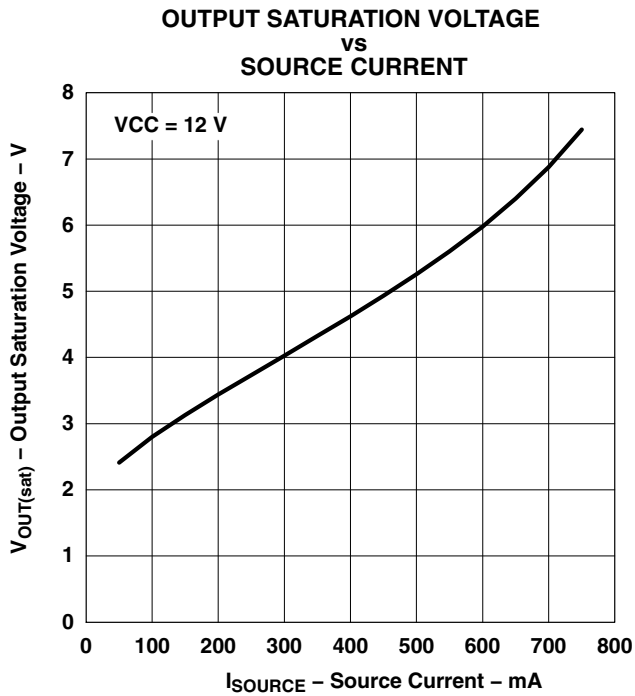

Figure 20

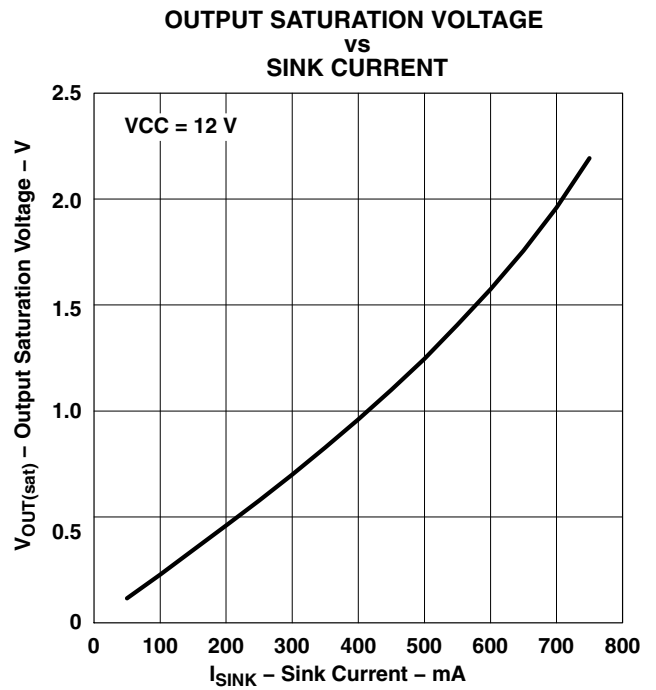

Figure 21

**UCC28050, UCC28051
UCC38050, UCC38051**

SLUS515F-SEPTEMBER 2002 - REVISED MARCH 2009

MECHANICAL DATA

D (R-PDSO-G)**

PLASTIC SMALL-OUTLINE PACKAGE

8 PINS SHOWN

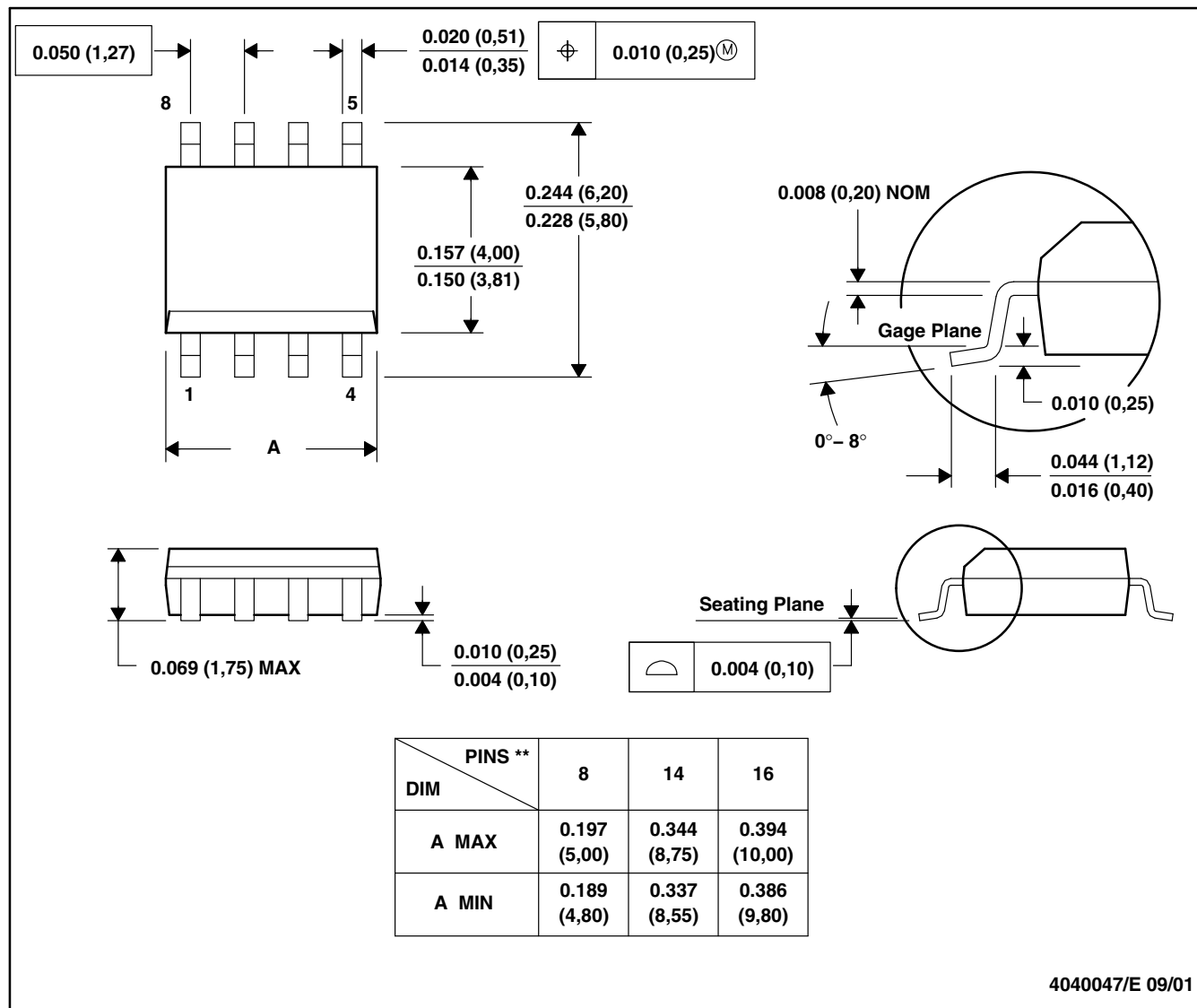

- NOTES: A. All linear dimensions are in inches (millimeters).
 B. This drawing is subject to change without notice.
 C. Body dimensions do not include mold flash or protrusion, not to exceed 0.006 (0,15).
 D. Falls within JEDEC MS-012

MECHANICAL DATA

P (PDIP)

PLASTIC DUAL-IN-LINE

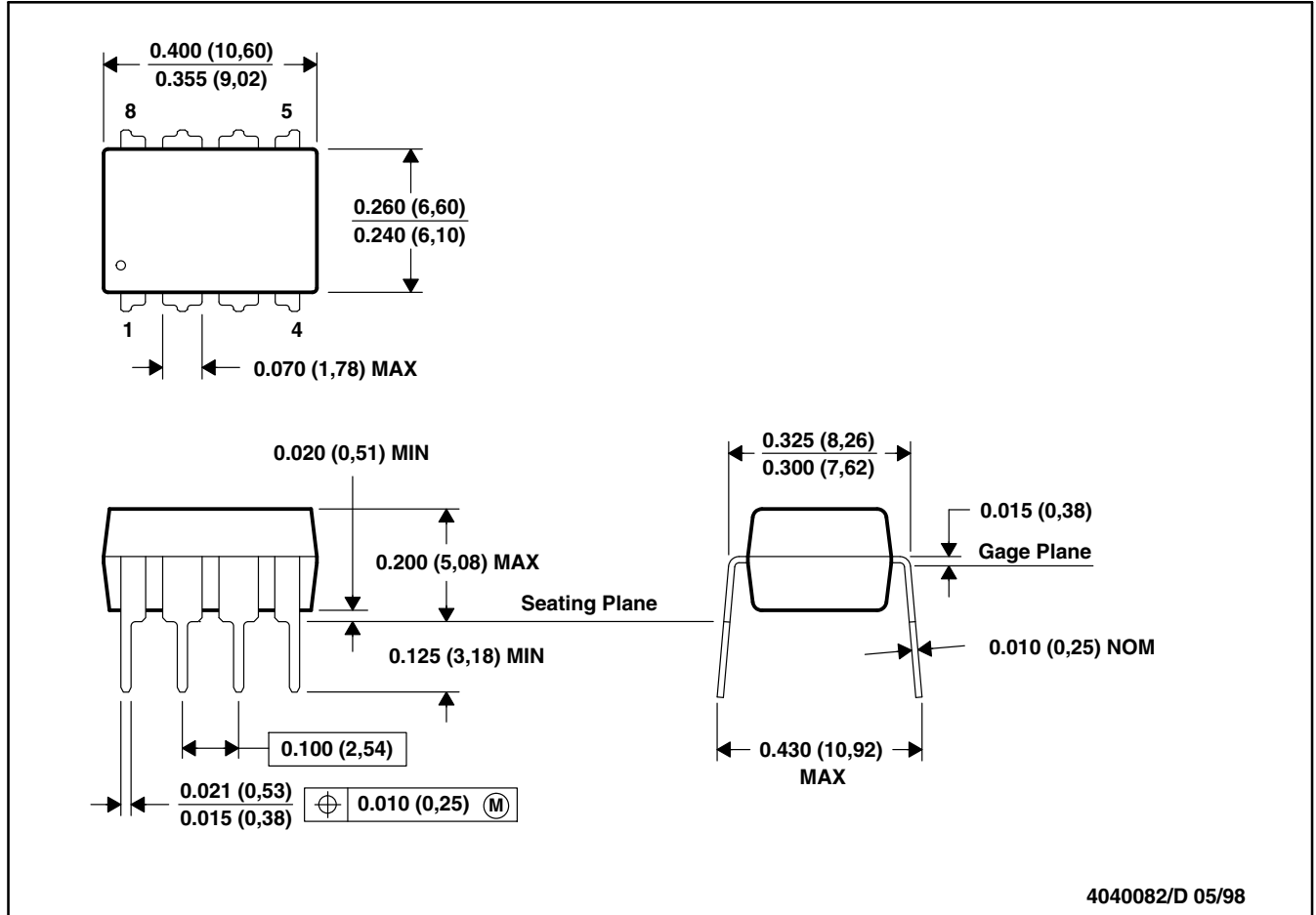

- NOTES: A. All linear dimensions are in inches (millimeters).
 B. This drawing is subject to change without notice.
 C. Falls within JEDEC MS-001

For the latest package information, go to http://www.ti.com/sc/docs/package/pkg_info.htm

PACKAGING INFORMATION

Orderable Device	Status (1)	Package Type	Package Drawing	Pins	Package Qty	Eco Plan (2)	Lead/Ball Finish	MSL Peak Temp (3)	Op Temp (°C)	Device Marking (4/5)	Samples
UCC28050D	ACTIVE	SOIC	D	8	75	Green (RoHS & no Sb/Br)	CU NIPDAU	Level-1-260C-UNLIM	-40 to 85	28050	Samples
UCC28050DG4	ACTIVE	SOIC	D	8	75	Green (RoHS & no Sb/Br)	CU NIPDAU	Level-1-260C-UNLIM	-40 to 85	28050	Samples
UCC28050DR	ACTIVE	SOIC	D	8	2500	Green (RoHS & no Sb/Br)	CU NIPDAU	Level-1-260C-UNLIM	-40 to 85	28050	Samples
UCC28050DRG4	ACTIVE	SOIC	D	8	2500	Green (RoHS & no Sb/Br)	CU NIPDAU	Level-1-260C-UNLIM	-40 to 85	28050	Samples
UCC28050P	ACTIVE	PDIP	P	8	50	Pb-Free (RoHS)	CU NIPDAU	N / A for Pkg Type	-40 to 85	28050	Samples
UCC28050PE4	ACTIVE	PDIP	P	8	50	Pb-Free (RoHS)	CU NIPDAU	N / A for Pkg Type	-40 to 85	28050	Samples
UCC28051D	ACTIVE	SOIC	D	8	75	Green (RoHS & no Sb/Br)	CU NIPDAU	Level-1-260C-UNLIM	-40 to 105	28051	Samples
UCC28051DG4	ACTIVE	SOIC	D	8	75	Green (RoHS & no Sb/Br)	CU NIPDAU	Level-1-260C-UNLIM	-40 to 105	28051	Samples
UCC28051DR	ACTIVE	SOIC	D	8	2500	Green (RoHS & no Sb/Br)	CU NIPDAU	Level-1-260C-UNLIM	-40 to 105	28051	Samples
UCC28051DRG4	ACTIVE	SOIC	D	8	2500	Green (RoHS & no Sb/Br)	CU NIPDAU	Level-1-260C-UNLIM	-40 to 105	28051	Samples
UCC28051P	ACTIVE	PDIP	P	8	50	Pb-Free (RoHS)	CU NIPDAU	N / A for Pkg Type	-40 to 105	28051	Samples
UCC28051PE4	ACTIVE	PDIP	P	8	50	Pb-Free (RoHS)	CU NIPDAU	N / A for Pkg Type	-40 to 105	28051	Samples
UCC38050D	ACTIVE	SOIC	D	8	75	Green (RoHS & no Sb/Br)	CU NIPDAU	Level-1-260C-UNLIM	0 to 70	38050	Samples
UCC38050DG4	ACTIVE	SOIC	D	8	75	Green (RoHS & no Sb/Br)	CU NIPDAU	Level-1-260C-UNLIM	0 to 70	38050	Samples
UCC38050DR	ACTIVE	SOIC	D	8	2500	Green (RoHS & no Sb/Br)	CU NIPDAU	Level-1-260C-UNLIM	0 to 70	38050	Samples
UCC38050DRG4	ACTIVE	SOIC	D	8	2500	Green (RoHS & no Sb/Br)	CU NIPDAU	Level-1-260C-UNLIM	0 to 70	38050	Samples
UCC38050P	ACTIVE	PDIP	P	8	50	Pb-Free (RoHS)	CU NIPDAU	N / A for Pkg Type	0 to 70	38050	Samples

Orderable Device	Status (1)	Package Type	Package Drawing	Pins	Package Qty	Eco Plan (2)	Lead/Ball Finish	MSL Peak Temp (3)	Op Temp (°C)	Device Marking (4/5)	Samples
UCC38050PE4	ACTIVE	PDIP	P	8	50	Pb-Free (RoHS)	CU NIPDAU	N / A for Pkg Type	0 to 70	38050	Samples
UCC38051D	ACTIVE	SOIC	D	8	75	Green (RoHS & no Sb/Br)	CU NIPDAU	Level-1-260C-UNLIM	0 to 70	38051	Samples
UCC38051DG4	ACTIVE	SOIC	D	8	75	Green (RoHS & no Sb/Br)	CU NIPDAU	Level-1-260C-UNLIM	0 to 70	38051	Samples
UCC38051PE4	ACTIVE	PDIP	P	8		TBD	Call TI	Call TI	0 to 70	38051	Samples

(1) The marketing status values are defined as follows:

ACTIVE: Product device recommended for new designs.

LIFEBUY: TI has announced that the device will be discontinued, and a lifetime-buy period is in effect.

NRND: Not recommended for new designs. Device is in production to support existing customers, but TI does not recommend using this part in a new design.

PREVIEW: Device has been announced but is not in production. Samples may or may not be available.

OBSOLETE: TI has discontinued the production of the device.

(2) Eco Plan - The planned eco-friendly classification: Pb-Free (RoHS), Pb-Free (RoHS Exempt), or Green (RoHS & no Sb/Br) - please check <http://www.ti.com/productcontent> for the latest availability information and additional product content details.

TBD: The Pb-Free/Green conversion plan has not been defined.

Pb-Free (RoHS): TI's terms "Lead-Free" or "Pb-Free" mean semiconductor products that are compatible with the current RoHS requirements for all 6 substances, including the requirement that lead not exceed 0.1% by weight in homogeneous materials. Where designed to be soldered at high temperatures, TI Pb-Free products are suitable for use in specified lead-free processes.

Pb-Free (RoHS Exempt): This component has a RoHS exemption for either 1) lead-based flip-chip solder bumps used between the die and package, or 2) lead-based die adhesive used between the die and leadframe. The component is otherwise considered Pb-Free (RoHS compatible) as defined above.

Green (RoHS & no Sb/Br): TI defines "Green" to mean Pb-Free (RoHS compatible), and free of Bromine (Br) and Antimony (Sb) based flame retardants (Br or Sb do not exceed 0.1% by weight in homogeneous material)

(3) MSL, Peak Temp. -- The Moisture Sensitivity Level rating according to the JEDEC industry standard classifications, and peak solder temperature.

(4) There may be additional marking, which relates to the logo, the lot trace code information, or the environmental category on the device.

(5) Multiple Device Markings will be inside parentheses. Only one Device Marking contained in parentheses and separated by a "~" will appear on a device. If a line is indented then it is a continuation of the previous line and the two combined represent the entire Device Marking for that device.

Important Information and Disclaimer: The information provided on this page represents TI's knowledge and belief as of the date that it is provided. TI bases its knowledge and belief on information provided by third parties, and makes no representation or warranty as to the accuracy of such information. Efforts are underway to better integrate information from third parties. TI has taken and continues to take reasonable steps to provide representative and accurate information but may not have conducted destructive testing or chemical analysis on incoming materials and chemicals. TI and TI suppliers consider certain information to be proprietary, and thus CAS numbers and other limited information may not be available for release.

In no event shall TI's liability arising out of such information exceed the total purchase price of the TI part(s) at issue in this document sold by TI to Customer on an annual basis.

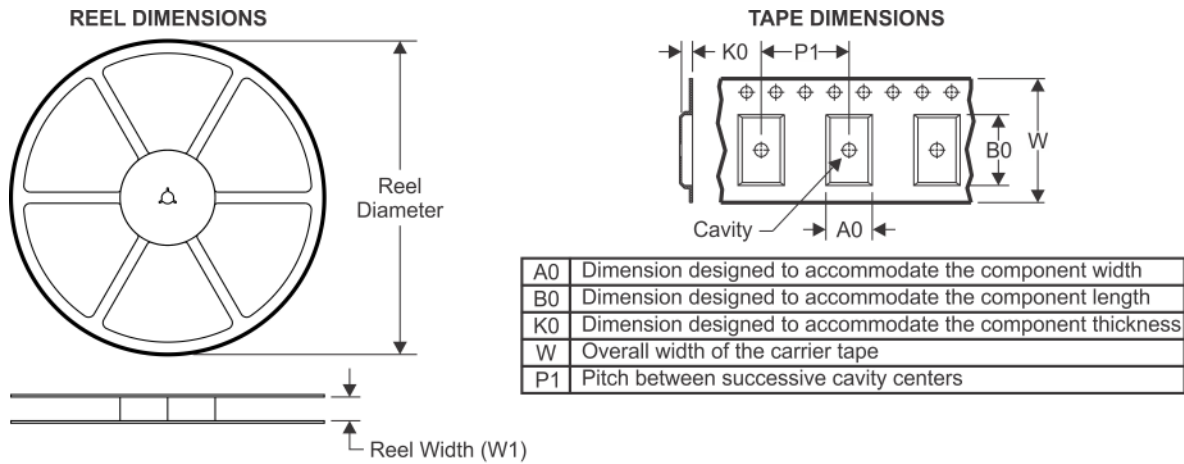
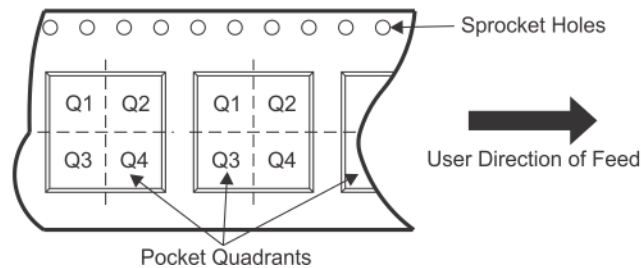
TAPE AND REEL INFORMATION

QUADRANT ASSIGNMENTS FOR PIN 1 ORIENTATION IN TAPE

*All dimensions are nominal

Device	Package Type	Package Drawing	Pins	SPQ	Reel Diameter (mm)	Reel Width W1 (mm)	A0 (mm)	B0 (mm)	K0 (mm)	P1 (mm)	W (mm)	Pin1 Quadrant
UCC28050DR	SOIC	D	8	2500	330.0	12.4	6.4	5.2	2.1	8.0	12.0	Q1
UCC28051DR	SOIC	D	8	2500	330.0	12.4	6.4	5.2	2.1	8.0	12.0	Q1
UCC38050DR	SOIC	D	8	2500	330.0	12.4	6.4	5.2	2.1	8.0	12.0	Q1

TAPE AND REEL BOX DIMENSIONS



*All dimensions are nominal

Device	Package Type	Package Drawing	Pins	SPQ	Length (mm)	Width (mm)	Height (mm)
UCC28050DR	SOIC	D	8	2500	340.5	338.1	20.6
UCC28051DR	SOIC	D	8	2500	340.5	338.1	20.6
UCC38050DR	SOIC	D	8	2500	340.5	338.1	20.6

P (R-PDIP-T8)

PLASTIC DUAL-IN-LINE PACKAGE

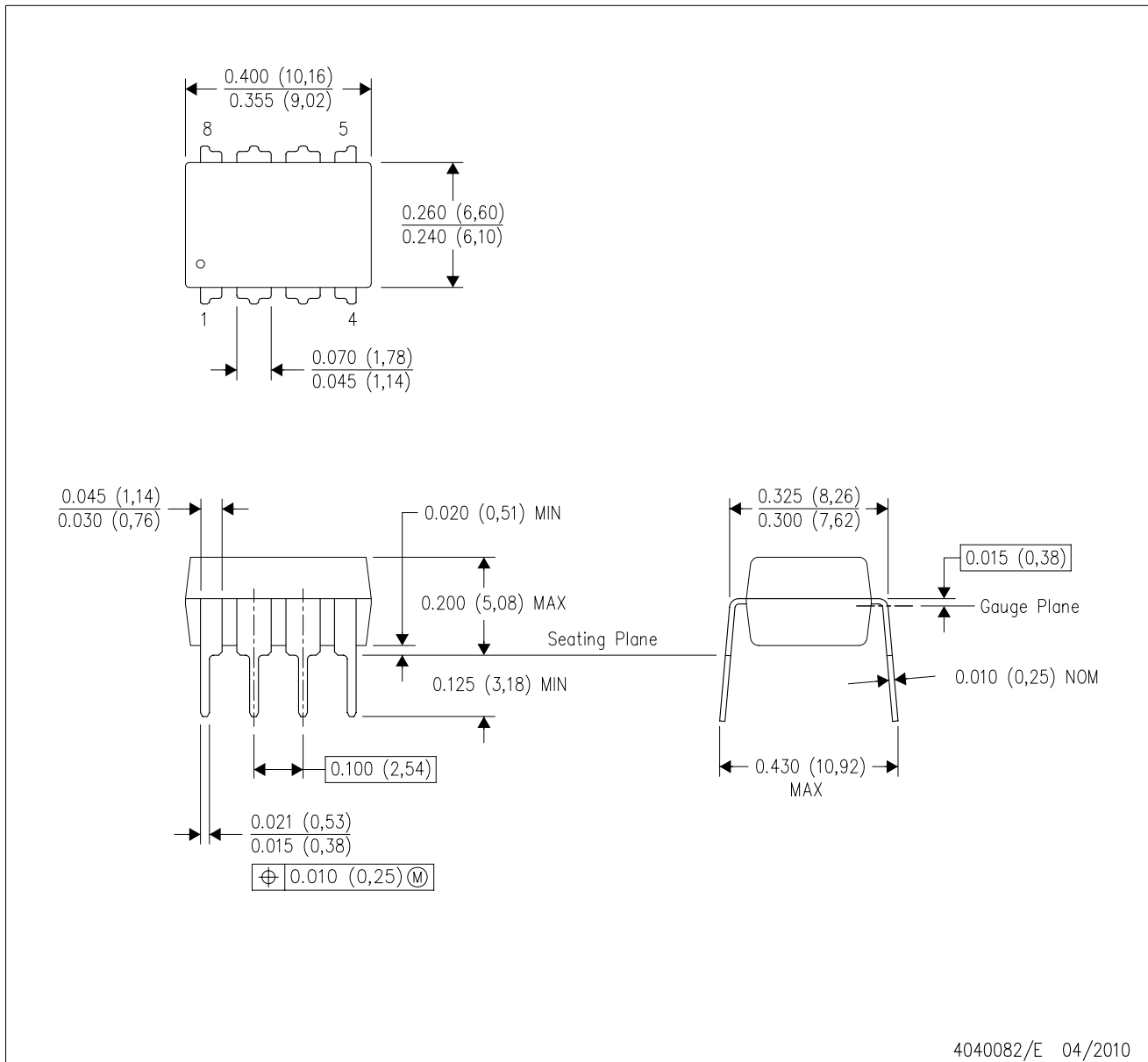

- NOTES:
- A. All linear dimensions are in inches (millimeters).
 - B. This drawing is subject to change without notice.
 - C. Falls within JEDEC MS-001 variation BA.

D (R-PDSO-G8)

PLASTIC SMALL OUTLINE

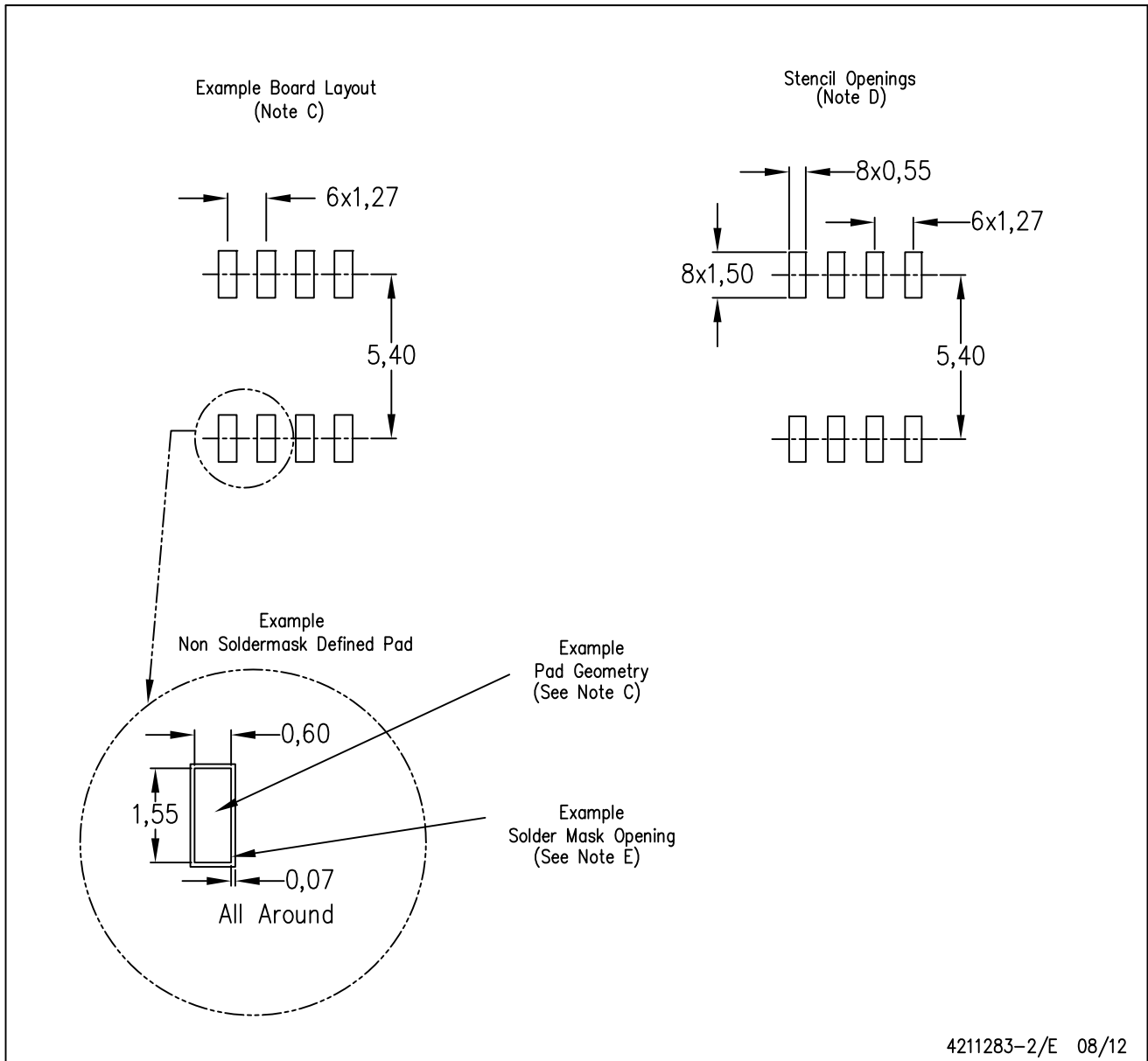

- NOTES:
- A. All linear dimensions are in millimeters.
 - B. This drawing is subject to change without notice.
 - C. Publication IPC-7351 is recommended for alternate designs.
 - D. Laser cutting apertures with trapezoidal walls and also rounding corners will offer better paste release. Customers should contact their board assembly site for stencil design recommendations. Refer to IPC-7525 for other stencil recommendations.
 - E. Customers should contact their board fabrication site for solder mask tolerances between and around signal pads.

IMPORTANT NOTICE

Texas Instruments Incorporated and its subsidiaries (TI) reserve the right to make corrections, enhancements, improvements and other changes to its semiconductor products and services per JESD46, latest issue, and to discontinue any product or service per JESD48, latest issue. Buyers should obtain the latest relevant information before placing orders and should verify that such information is current and complete. All semiconductor products (also referred to herein as "components") are sold subject to TI's terms and conditions of sale supplied at the time of order acknowledgment.

TI warrants performance of its components to the specifications applicable at the time of sale, in accordance with the warranty in TI's terms and conditions of sale of semiconductor products. Testing and other quality control techniques are used to the extent TI deems necessary to support this warranty. Except where mandated by applicable law, testing of all parameters of each component is not necessarily performed.

TI assumes no liability for applications assistance or the design of Buyers' products. Buyers are responsible for their products and applications using TI components. To minimize the risks associated with Buyers' products and applications, Buyers should provide adequate design and operating safeguards.

TI does not warrant or represent that any license, either express or implied, is granted under any patent right, copyright, mask work right, or other intellectual property right relating to any combination, machine, or process in which TI components or services are used. Information published by TI regarding third-party products or services does not constitute a license to use such products or services or a warranty or endorsement thereof. Use of such information may require a license from a third party under the patents or other intellectual property of the third party, or a license from TI under the patents or other intellectual property of TI.

Reproduction of significant portions of TI information in TI data books or data sheets is permissible only if reproduction is without alteration and is accompanied by all associated warranties, conditions, limitations, and notices. TI is not responsible or liable for such altered documentation. Information of third parties may be subject to additional restrictions.

Resale of TI components or services with statements different from or beyond the parameters stated by TI for that component or service voids all express and any implied warranties for the associated TI component or service and is an unfair and deceptive business practice. TI is not responsible or liable for any such statements.

Buyer acknowledges and agrees that it is solely responsible for compliance with all legal, regulatory and safety-related requirements concerning its products, and any use of TI components in its applications, notwithstanding any applications-related information or support that may be provided by TI. Buyer represents and agrees that it has all the necessary expertise to create and implement safeguards which anticipate dangerous consequences of failures, monitor failures and their consequences, lessen the likelihood of failures that might cause harm and take appropriate remedial actions. Buyer will fully indemnify TI and its representatives against any damages arising out of the use of any TI components in safety-critical applications.

In some cases, TI components may be promoted specifically to facilitate safety-related applications. With such components, TI's goal is to help enable customers to design and create their own end-product solutions that meet applicable functional safety standards and requirements. Nonetheless, such components are subject to these terms.

No TI components are authorized for use in FDA Class III (or similar life-critical medical equipment) unless authorized officers of the parties have executed a special agreement specifically governing such use.

Only those TI components which TI has specifically designated as military grade or "enhanced plastic" are designed and intended for use in military/aerospace applications or environments. Buyer acknowledges and agrees that any military or aerospace use of TI components which have **not** been so designated is solely at the Buyer's risk, and that Buyer is solely responsible for compliance with all legal and regulatory requirements in connection with such use.

TI has specifically designated certain components as meeting ISO/TS16949 requirements, mainly for automotive use. In any case of use of non-designated products, TI will not be responsible for any failure to meet ISO/TS16949.

Products

Audio	www.ti.com/audio
Amplifiers	amplifier.ti.com
Data Converters	dataconverter.ti.com
DLP® Products	www.dlp.com
DSP	dsp.ti.com
Clocks and Timers	www.ti.com/clocks
Interface	interface.ti.com
Logic	logic.ti.com
Power Mgmt	power.ti.com
Microcontrollers	microcontroller.ti.com
RFID	www.ti-rfid.com
OMAP Applications Processors	www.ti.com/omap
Wireless Connectivity	www.ti.com/wirelessconnectivity

Applications

Automotive and Transportation	www.ti.com/automotive
Communications and Telecom	www.ti.com/communications
Computers and Peripherals	www.ti.com/computers
Consumer Electronics	www.ti.com/consumer-apps
Energy and Lighting	www.ti.com/energy
Industrial	www.ti.com/industrial
Medical	www.ti.com/medical
Security	www.ti.com/security
Space, Avionics and Defense	www.ti.com/space-avionics-defense
Video and Imaging	www.ti.com/video

TI E2E Community

e2e.ti.com