

177920501, 177920511, 177920521, 177920531

## MagI<sup>3</sup>C Power Module FISM – Fixed Isolated SIP Module



3.3V – 24V / 1W / 1kV functional isolated  
unregulated 5V Output

### DESCRIPTION

The FISM series of the unregulated MagI<sup>3</sup>C power module family is a functional isolated, fully integrated DC/DC converter. The module integrates the switching power stage, control circuitry, transformer and capacitors, all in one package.

The module requires no external components for operation thus reducing design effort and complexity to a minimum.

The FISM ensures fast time to market and low development costs.

The FISM series achieves typically an efficiency of 79% to 80%.

The THT package (11.50x6x10mm) with industrial standard SIP-4 pinout allows for easy assembly.

### FEATURES

- 1kV DC functional isolation
- Current capability up to 0.2A
- Nominal input voltage rails: 3.3V / 5V / 12V / 24V
- Output voltage: 5V unregulated
- No minimum load required
- Continuous output power: 1W
- Integrated C<sub>IN</sub>, C<sub>OUT</sub> and transformer
- Low output voltage ripple: typ. 55mV at full load
- Output voltage accuracy: ±5% max.
- Operating frequency range: 50 kHz to 105 kHz
- Operating ambient temperature range:- 40°C to 85°C
- RoHS & REACH compliant
- UL94V-0 package material
- Complies with EN55032 class B conducted and radiated emissions standard
- UL60950-1, 2<sup>nd</sup> Edition
- C22.2 No. 60950-1-07 2nd Edition
- IEC/EN60950-1, 2nd Edition

### TYPICAL APPLICATIONS

- Data acquisition
- Test and measurement systems
- Interface and microcontroller supply
- Industrial control

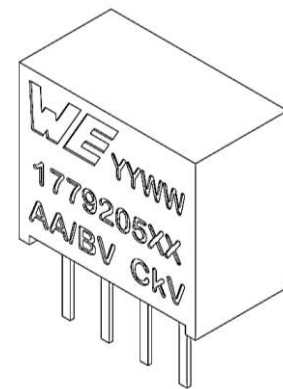

### TYPICAL CIRCUIT DIAGRAM

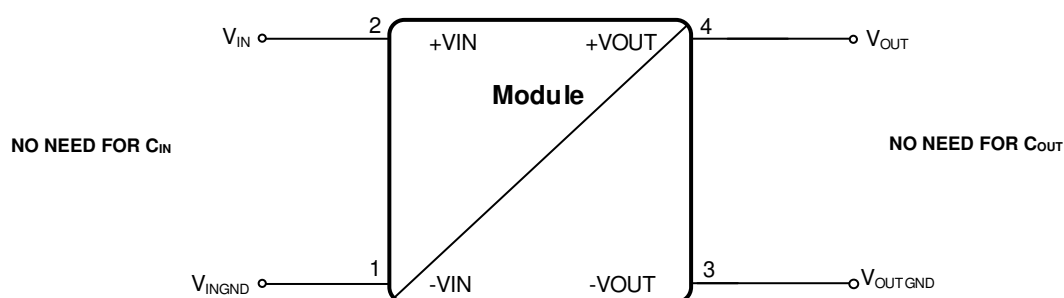

177920501, 177920511, 177920521, 177920531

**MagI<sup>3</sup>C** Power Module  
**FISM** – Fixed Isolated SIP Module



### MARKING DESCRIPTION

MARKING	DESCRIPTION
WE	Würth Elektronik tradename
YY	Year
WW	Calendar week
1779205XX	Ordering code
AA	Input voltage
B	Output voltage
C	Isolation voltage

### PACKAGE

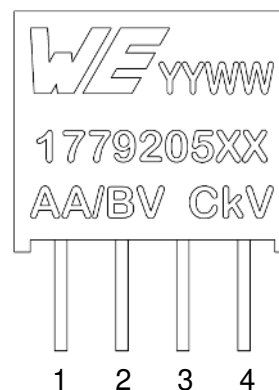

### PIN DESCRIPTION

SYMBOL	NUMBER	TYPE	DESCRIPTION
- VIN	1	Power	Input ground
+ VIN	2	Power	Input voltage
-VOUT	3	Power	Output ground
+VOUT	4	Power	Output voltage

### ORDERING INFORMATION

ORDER CODE	PART DESCRIPTION	SPECIFICATIONS	PACKAGE	PACKAGING UNIT
177920501	WPMIC9200501S	3.3V <sub>IN</sub> / 5V <sub>OUT</sub> version	SIP-4	Tube with 42 pieces
177920511	WPMIB9200501S	5V <sub>IN</sub> / 5V <sub>OUT</sub> version	SIP-4	Tube with 42 pieces
177920521	WPMIA9200501S	12V <sub>IN</sub> / 5V <sub>OUT</sub> version	SIP-4	Tube with 42 pieces
177920531	WPMID9200501S	24V <sub>IN</sub> / 5V <sub>OUT</sub> version	SIP-4	Tube with 42 pieces
1789205X1		3.3 to 24V <sub>IN</sub> / 5V <sub>OUT</sub>	Eval Board	1

### SALES INFORMATION

SALES CONTACTS
<p>Würth Elektronik eiSos GmbH &amp; Co. KG            EMC &amp; Inductive Solutions            Max-Eyth-Str. 1            74638 Waldenburg            Germany            Tel. +49 (0) 7942 945 0  <a href="http://www.we-online.com/powermodules">www.we-online.com/powermodules</a>            Technical support: <a href="mailto:powermodules@we-online.com">powermodules@we-online.com</a></p>

177920501, 177920511, 177920521, 177920531

**MagI<sup>3</sup>C** Power Module  
**FISM – Fixed Isolated SIP Module**



## ABSOLUTE MAXIMUM RATINGS

Caution:

Exceeding the listed absolute maximum ratings may affect the device negatively and may cause permanent damage. These are stress ratings only, which do not imply functional operation of the device at these or any other condition beyond those indicated under "Operation Conditions".

SYMBOL	PARAMETER	LIMITS		UNIT	
		MIN <sup>(1)</sup>	MAX <sup>(1)</sup>		
V <sub>IN</sub>	Input pin voltage for 10s@10% Load	3.3V <sub>IN</sub> / 5V <sub>OUT</sub> version, (177920501)	2.64	3.96	V
		5V <sub>IN</sub> / 5V <sub>OUT</sub> version, (177920511)	4.00	5.75	V
		12V <sub>IN</sub> / 5V <sub>OUT</sub> version, (177920521)	9.60	13.8	V
		24V <sub>IN</sub> / 5V <sub>OUT</sub> version, (177920531)	19.2	27.6	V
V <sub>OUT</sub>	Output pin voltage (1779205X1)	0	10	V	
V <sub>ISO</sub>	Isolation voltage input to output, 100% tested for 1 second <sup>(2)</sup>	-	1000	V	
	Isolation voltage input to output 60 seconds <sup>(10)</sup>	-	800	V	
T <sub>storage</sub>	Assembled, non-operating storage temperature	-55	125	°C	
V <sub>ESD</sub>	ESD Voltage (Human Body Model), according to EN61000-4-2 <sup>(11)</sup>	-	±2000	V	

## OPERATING CONDITIONS

Operating conditions are conditions under which operation of the device is intended to be functional. All values are referenced to respective GND.

MIN and MAX limits are valid for the ambient temperature of **25°C**. Typical values represents statistically the utmost probability at following conditions: T<sub>A</sub> = 25°C V<sub>IN</sub> = 3.3V, V<sub>OUT</sub> = 5V (177920501), V<sub>IN</sub> = 5V V<sub>OUT</sub> = 5V (177920511), V<sub>IN</sub> = 12V, V<sub>OUT</sub> = 5V (177920521), V<sub>IN</sub> = 24V, V<sub>OUT</sub> = 5V (177920531), I<sub>OUT</sub> = 0.2A unless otherwise noted.

SYMBOL	PARAMETER	MIN <sup>(1)</sup>	TYP <sup>(3)</sup>	MAX <sup>(1)</sup>	UNIT	
V <sub>IN</sub>	Input voltage	3.3V <sub>IN</sub> / 5V <sub>OUT</sub> version, 177920501	2.97	3.3	3.63	V
		5V <sub>IN</sub> / 5V <sub>OUT</sub> version, (177920511)	4.5	5	5.5	V
		12V <sub>IN</sub> / 5V <sub>OUT</sub> version, 177920521	10.8	12	13.2	V
		24V <sub>IN</sub> / 5V <sub>OUT</sub> version, 177920531	21.6	24	26.4	V
V <sub>OUT</sub>	Nominal output voltage (I <sub>OUT</sub> Range 10% to 100%)	4.75	5	5.25	V	
I <sub>OUT</sub>	Nominal output current <sup>(4)</sup>	0	-	200	mA	
P <sub>OUT</sub>	Nominal output power	-	-	1	W	
C <sub>OUT MAX</sub>	Maximum output capacitor for default startup time <sup>(5)</sup>		1779205x1	470	µF	
T <sub>A</sub>	Ambient temperature range	-40	-	85	°C	

All parameters are specified after a 5 minutes run-in time unless otherwise noted.

177920501, 177920511, 177920521, 177920531

**MagI<sup>3</sup>C** Power Module  
**FISM** – Fixed Isolated SIP Module

**THERMAL SPECIFICATIONS**

SYMBOL	PARAMETER	TYP <sup>(3)</sup>	UNIT
$\Theta_{CA}$	Case-to-ambient thermal resistance <sup>(5)</sup>	60	°C/W
$T_{case\ max}$	Maximum case temperature	105	°C

**PACKAGE SPECIFICATIONS**

ITEM	PARAMETER	TYP <sup>(2)</sup>	UNIT
Case	UL94V-0 (Refer to UL approval E150608)	-	-
Potting	UL94V-0 (Refer to UL approval E129811)	-	-
$\varphi$ (RH)	Operating humidity	5 - 95	%
Weight		1.4	g
Vibration	MIL-STD-202G: 5g's for 20 minutes, 12 cycles each of 3 orientations, test from 15Hz-2000 Hz.		

177920501, 177920511, 177920521, 177920531

**MagI<sup>3</sup>C** Power Module  
**FISM – Fixed Isolated SIP Module**



## ELECTRICAL SPECIFICATIONS

MIN and MAX limits are valid for the ambient temperature of **25°C**. Typical values represents statistically the utmost probability at following conditions:  $T_A = 25^\circ\text{C}$ ,  $V_{IN} = 3.3\text{V}$ ,  $V_{OUT} = 5\text{V}$  (177920501),  $V_{IN} = 5\text{V}$ ,  $V_{OUT} = 5\text{V}$  (177920511),  $V_{IN} = 12\text{V}$ ,  $V_{OUT} = 5\text{V}$  (177920521),  $V_{IN} = 24\text{V}$ ,  $V_{OUT} = 5\text{V}$  (177920531),  $I_{OUT} = 0.2\text{A}$  unless otherwise noted.

SYMBOL	PARAMETER	TEST CONDITIONS	MIN <sup>(1)</sup>	TYP <sup>(3)</sup>	MAX <sup>(1)</sup>	UNIT
<b>Output Current</b>						
$I_{MOC}$	Maximum overload current	5s	-	-	300 <sup>(6)</sup>	mA
$I_{CL}$	Current limit threshold		-	-	No <sup>(7)</sup>	mA
<b>Accuracy</b>						
$V_{OUT}$	Line regulation	per 1.0% change in input voltage <sup>(8)</sup>	-	$\pm 1.2$	-	%
	Load regulation	10% to 100% load current, 5V <sub>out</sub> – see tolerance envelope	-	-	-5 +15	%
	Output voltage accuracy	$V_{in}$ nominal	-	-	$\pm 5$	%
	Output voltage ripple 5V <sub>OUT</sub>	20MHz BW, without external MLCC capacitor	-	55	-	mV <sub>pp</sub>
<b>Switching frequency</b>						
$f_{SW}$	Switching frequency	1779205X1	50	-	105	kHz
<b>Input current</b>						
$I_{IN}$	No load input current (operating, switching)	$V_{IN}=3.3\text{V}$ , $V_{OUT}=5\text{V}$ , $I_{OUT}=0\text{mA}$ (177920501)	-	44	-	mA
		$V_{IN}=5\text{V}$ , $V_{OUT}=5\text{V}$ , $I_{OUT}=0\text{mA}$ (177920511)	-	30	-	mA
		$V_{IN}=12\text{V}$ , $V_{OUT}=5\text{V}$ , $I_{OUT}=0\text{mA}$ (177920521)	-	25	-	mA
		$V_{IN}=24\text{V}$ , $V_{OUT}=5\text{V}$ , $I_{OUT}=0\text{mA}$ (177920531)	-	10	-	mA
<b>Efficiency</b>						
$\eta$	Efficiency	$V_{IN}=3.3\text{V}$ , $V_{OUT}=5\text{V}$ , $I_{OUT}=200\text{mA}$ (177920501)	-	79	-	%
		$V_{IN}=5\text{V}$ , $V_{OUT}=5\text{V}$ , $I_{OUT}=200\text{mA}$ (177920511)	-	79	-	%
		$V_{IN}=12\text{V}$ , $V_{OUT}=5\text{V}$ , $I_{OUT}=200\text{mA}$ (177920521)	-	80	-	%
		$V_{IN}=24\text{V}$ , $V_{OUT}=5\text{V}$ , $I_{OUT}=200\text{mA}$ (177920531)	-	80	-	%
<b>Isolation characteristics</b>						
$C_{ISO}$	Isolation capacitance		-	-	75	pF
$R_{ISO}$	Isolation resistance		1	-	-	GΩ

## RELIABILITY



SYMBOL	PARAMETER	CONDITIONS	MIN <sup>(1)</sup>	TYP <sup>(3)</sup>	MAX <sup>(1)</sup>	UNIT
MTBF <sup>(9)</sup>	Mean Time Between Failures	+25°C: Ground Benign	22380 x10 <sup>3</sup>			h
		+85°C: Ground Benign	9300 x10 <sup>3</sup>			h

177920501, 177920511, 177920521, 177920531

**MagI<sup>3</sup>C** Power Module  
**FISM – Fixed Isolated SIP Module**



### APPROVALS

SYMBOL	STANDARD	DESCRIPTION
	UL60950-1, 2 <sup>nd</sup> Edition, 2007-03-27	Recognized for use as Information Technology Equipment, U.S.A. (UL60950-1) and Canada (C22.2 No. 60950-1) E-File: E487909 Applicable for altitudes up to 2000m
	IEC/EN 60950-1	CB Scheme, Information Technology Equipment

### RoHS, REACH

RoHS Directive		Directive 2011/65/EU of the European Parliament and the Council of June 8th, 2011 on the restriction of the use of certain hazardous substances in electrical and electronic equipment.
REACH Directive		Directive 1907/2006/EU of the European Parliament and the Council of June 1st, 2007 regarding the Registration, Evaluation, Authorisation and Restriction of Chemicals (REACH)

### NOTES

- (1) Min and Max limits are 100% production tested at 25°C. Limits over the operating temperature range are guaranteed through correlation using Statistical Quality Control (SQC) methods.
- (2) Test voltage as defined by the UL60950-1.
- (3) Typical numbers are valid at 25°C ambient temperature and represent statistically the utmost probability assuming the Gaussian distribution.
- (4) Depending on temperature, see thermal derating diagram ([OUTPUT POWER](#)).
- (5) Measured without heatsink, still air (0 – 20LFM / 0 – 0.1m/s).
- (6) Overload current, see [IMOC DUTY CYCLE](#) & [IMOC TEMPERATURE DERATING](#).
- (7) The module output is not current limited or short circuit protected. Continuous operation above the nominal current will damage the device.
- (8) Within the complete  $V_{IN}$  tolerance range.
- (9) MIL-HDBK-217F; GB Ground, Benign: Non mobile, temperature and humidity controlled environments readily accessible to maintenance; includes laboratory instruments and test equipment, medical electronic equipment, business and scientific computer complexes, and missiles and support equipment in ground silos; MTBF value is referring to 177920501.
- (10) Not production tested. The insulation equivalence is a rated value and based on indicative nature.
- (11) The human body model is a 100pF capacitor discharged through a 1.5 kΩ resistor into each pin. Test method is per JESD-22-114.

177920501, 177920511, 177920521, 177920531

## MagI<sup>3</sup>C Power Module FISM – Fixed Isolated SIP Module



### INTENDED USE – Typical Application

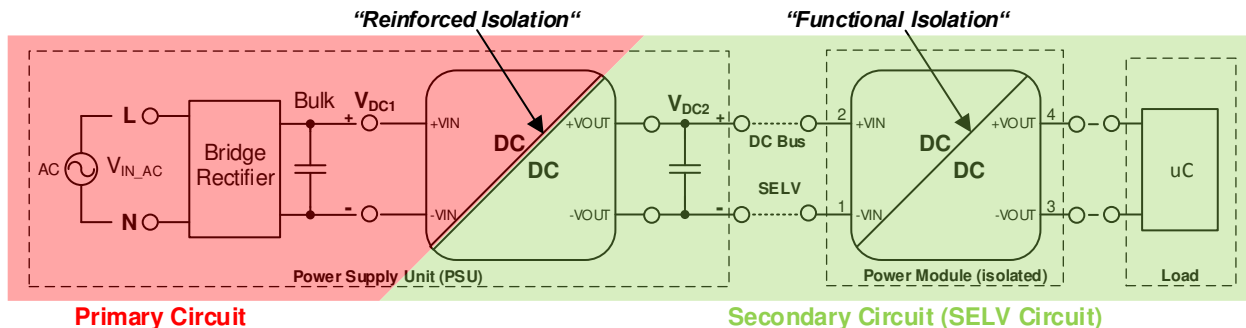

The 1779205x1 MagI<sup>3</sup>C power modules are only intended to be used as a CLASS III equipment according to the UL60950-1 standard. That requires that the power module is supplied by a **SELV** (safe extra low voltage) circuit which provides protection against electric shock. There are no HAZARDOUS voltages present in CLASS III Equipment.

A **SELV** circuit is a **secondary circuit** that is designed to be protected from excessive voltages ( $\geq 42$  Vac or  $\geq 60$  Vdc) during normal operating conditions and single fault conditions. A reinforced isolation is required at the boundary between the primary and the secondary circuit.

A circuit which has no direct connection to the primary circuit and derives its power from a transformer, converter or equivalently isolated device, or a battery, is defined as a **secondary circuit**.

In accordance to the safety standard UL60950-1, functional isolation (insulation) is defined as:

*“1.2.9.1 Functional Insulation: insulation that is necessary only for the correct functioning of the equipment*

*NOTE: Functional Insulation by definition does not protect against electric shock. It may, however, reduce the likelihood of ignition and fire.”*

*“1.2.9.5 Reinforced Insulation: single insulation system that provides a degree of protection against electric shock equivalent to Double Insulation under the conditions specified in this standard.*

*NOTE: The Term “insulation system” does not imply that the insulation has to be in one homogeneous piece. It may comprise several layers that cannot be tested as Basic Insulation and Supplementary Insulation*

The above figure shows a typical application of an isolated power module.  $V_{DC1}$  is a hazardous voltage and  $V_{DC2}$  is a SELV voltage.

### ISOLATION VOLTAGE

To verify the integrity of an isolation a test voltage is applied for a specified time across a component that is designed to provide electrical isolation. This test is known as a ‘Hi Pot Test’, ‘Flash Tested’, ‘Withstand Voltage’, ‘Proof Voltage’, ‘Dielectric Withstand Voltage’ & ‘Isolation Test Voltage’.

All isolated power modules are all 100% production tested at their stated isolation voltage. This is 1kVDC for 1 second.

The isolation test voltage indicated in this datasheet is for voltage transient immunity only. It does not allow this part to be used within a safety isolation system.

The part will function properly with several hundreds of volts applied continuously across the isolation barrier, however surrounding components must be individually analyzed to ensure proper insulation. Isolation measures are taken in to account to prevent any user-accessible circuitry from causing harm.

177920501, 177920511, 177920521, 177920531

**MagI<sup>3</sup>C** Power Module  
**FISM** – Fixed Isolated SIP Module



### Dielectric Strength test setup (High Pot Test)

Connect all input – and output terminals together (see figure below) before connecting the supply voltage. When testing, set the cut-off current to 1mA.

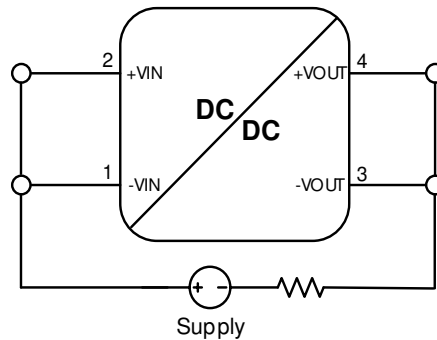

Parameters Supply Device: Current limit set 1mA, Test voltage 1000Vdc, Test time 1sec.

### REPEATED HIGH-VOLTAGE ISOLATION TESTING

A repeated high voltage test of a barrier component will degrade its isolation capabilities.

The primary and secondary windings within this transformer are enameled (coated) but do not possess additional isolation. Typically, parts can withstand many times their stated test voltage and still perform optimally. The magnet wire coating can degrade over time due to chemical reactions that occur at high voltages. We recommend keeping high voltage isolation testing to a minimum to better protect the isolation between the windings. If repeated high voltage isolation testing is required, consider reducing the voltage by a significant amount e.g. 20% from the test voltage stated within the datasheet.

These safety concerns are equally applicable to components that utilize functional isolation beyond wire coating (i.e. physical barriers or spacing).



177920501, 177920511, 177920521, 177920531

**MagI<sup>3</sup>C** Power Module  
**FISM – Fixed Isolated SIP Module**



**TYPICAL PERFORMANCE CURVES**

If not otherwise specified, the following conditions apply:  $T_{AMB} = 25^{\circ}C$ .

**RADIATED AND CONDUCTED EMISSIONS (WITH EMI INPUT FILTER)**

The 1779205X1 power modules were tested in several EMC configurations to give more realistic information about implementation in the applications. The test setup is based on CISPR16 with the limit values of CISPR32

**FILTER SETUP – MLCC capacitors**

Long wire connection - Using a MLCC based filter

Input wire length of 80cm, the load is connected with 80cm twisted wire to the output of the power module.

3.3V → 5V (177920501)

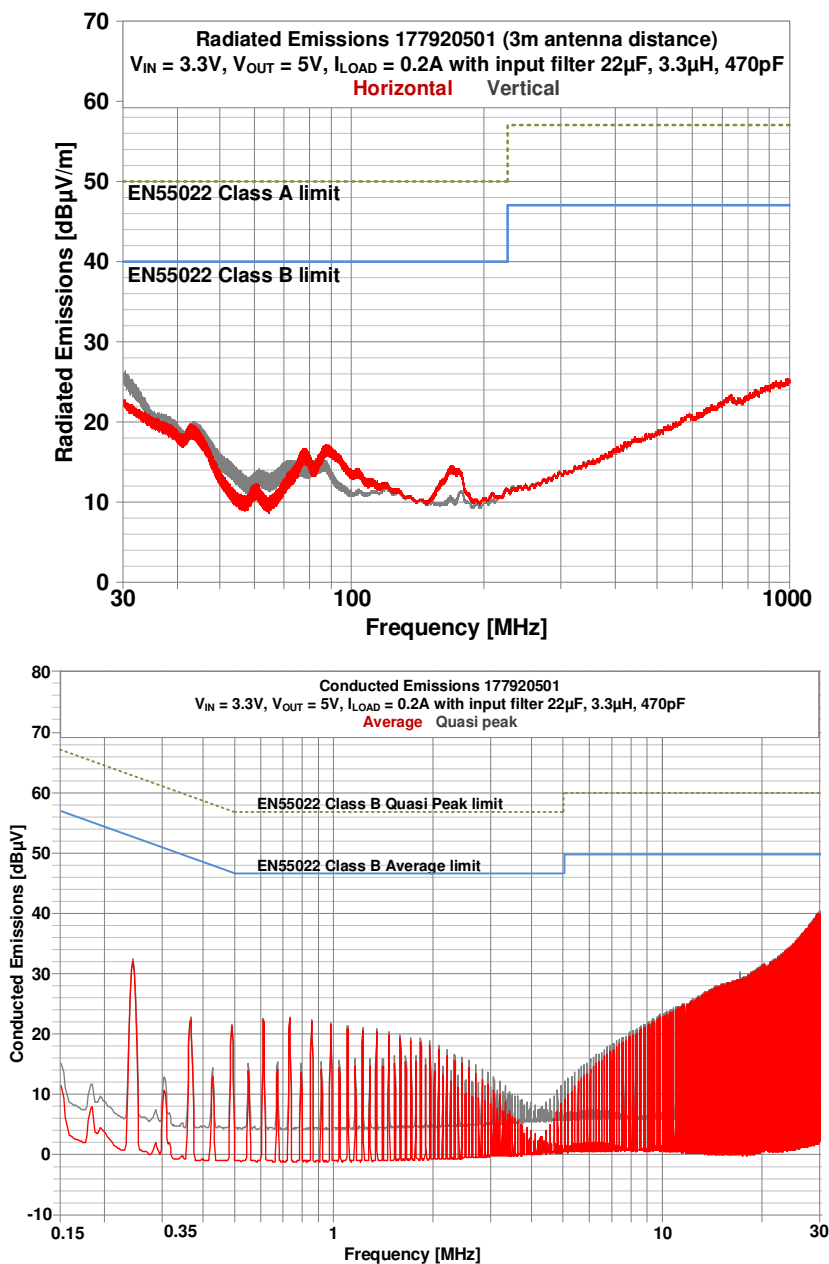

177920501, 177920511, 177920521, 177920531

**MagI<sup>3</sup>C** Power Module  
**FISM – Fixed Isolated SIP Module**



5V → 5V (177920511)

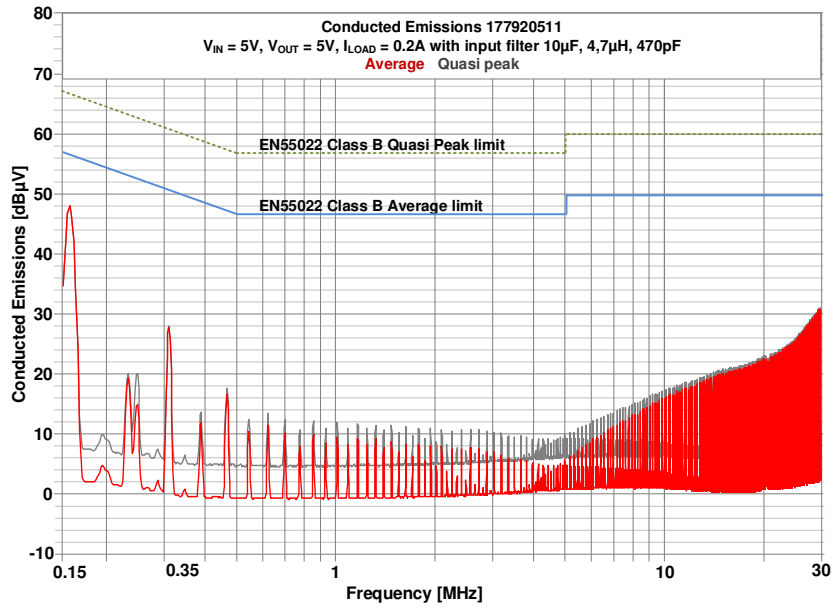
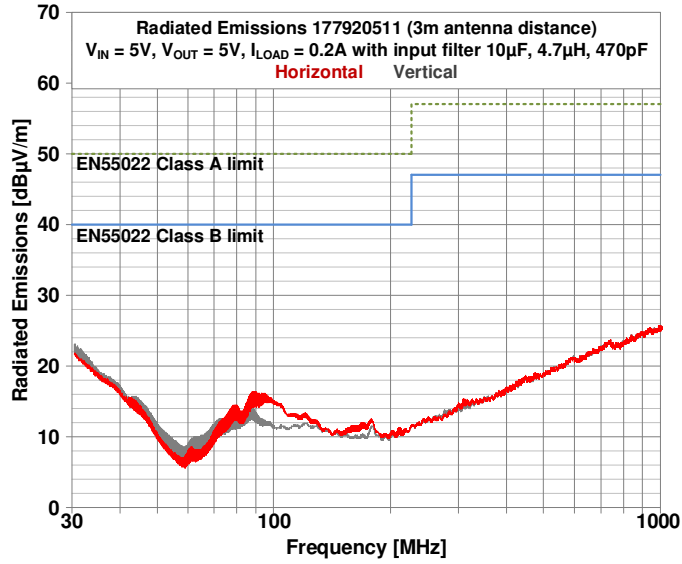

177920501, 177920511, 177920521, 177920531

**MagI<sup>3</sup>C** Power Module  
**FISM – Fixed Isolated SIP Module**



12V → 5V (177920521)

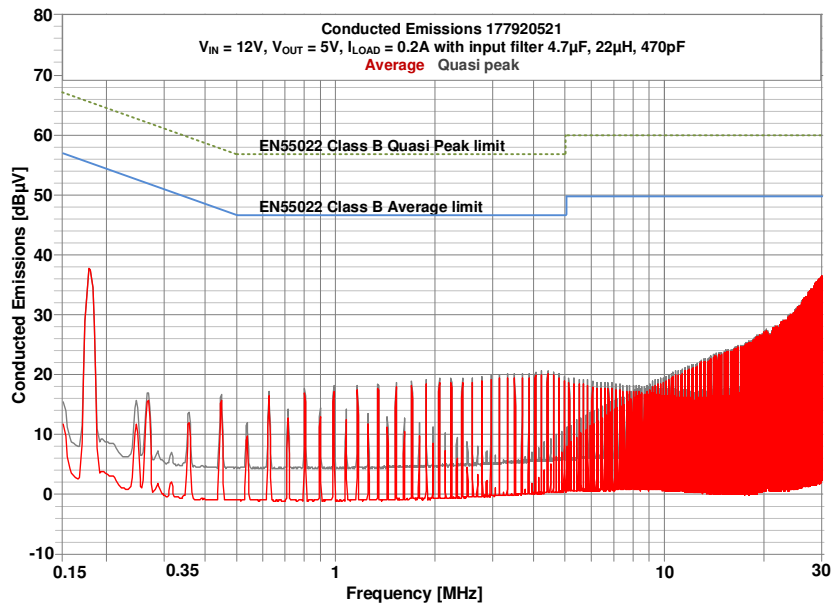
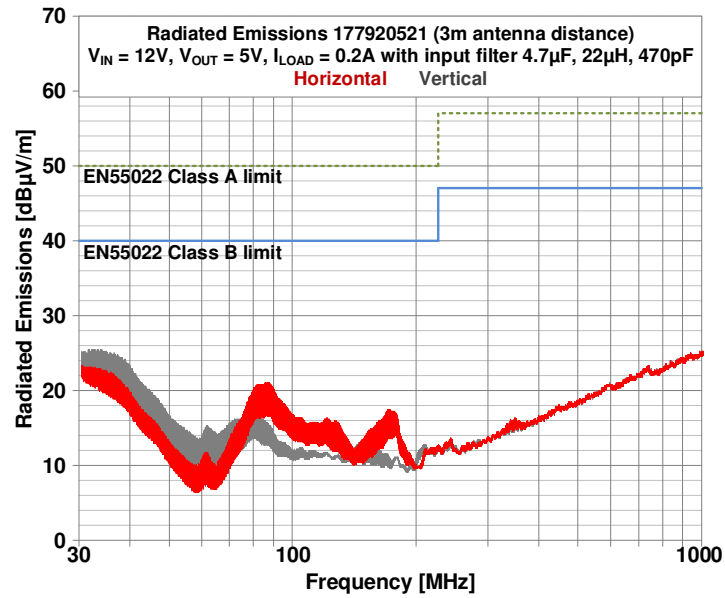

177920501, 177920511, 177920521, 177920531

**MagI<sup>3</sup>C** Power Module  
**FISM – Fixed Isolated SIP Module**



24V → 5V (177920531)

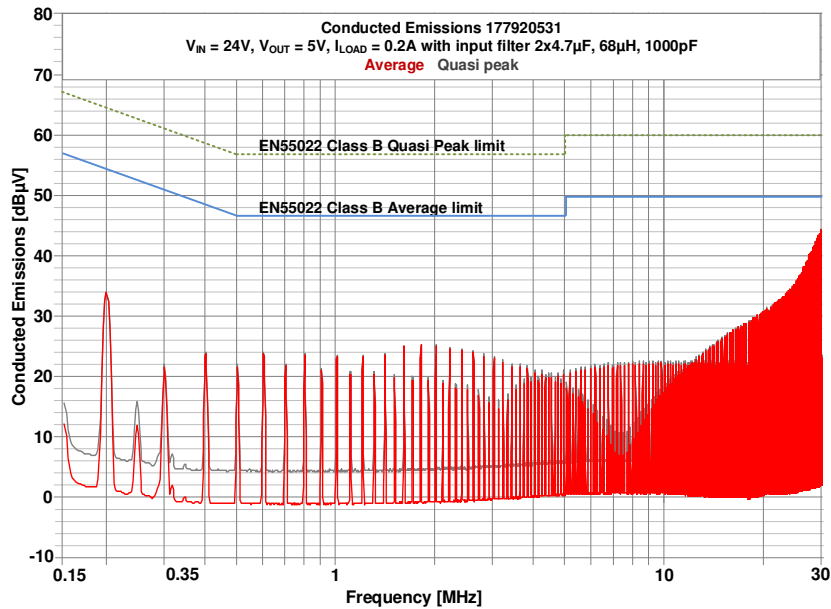
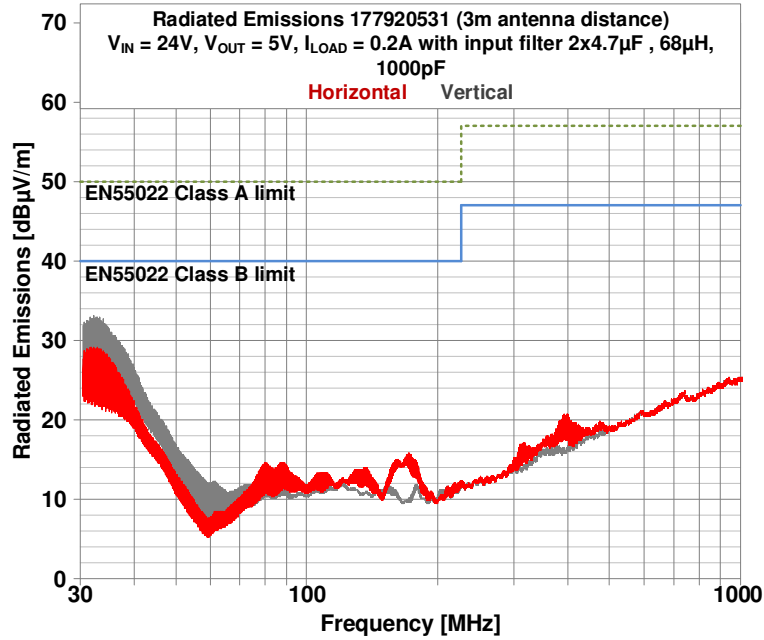

177920501, 177920511, 177920521, 177920531

**MagI<sup>3</sup>C** Power Module  
**FISM – Fixed Isolated SIP Module**



**EFFICIENCY**

**177920501 Efficiency - Vin = 3.3V, T<sub>A</sub>=25°C**

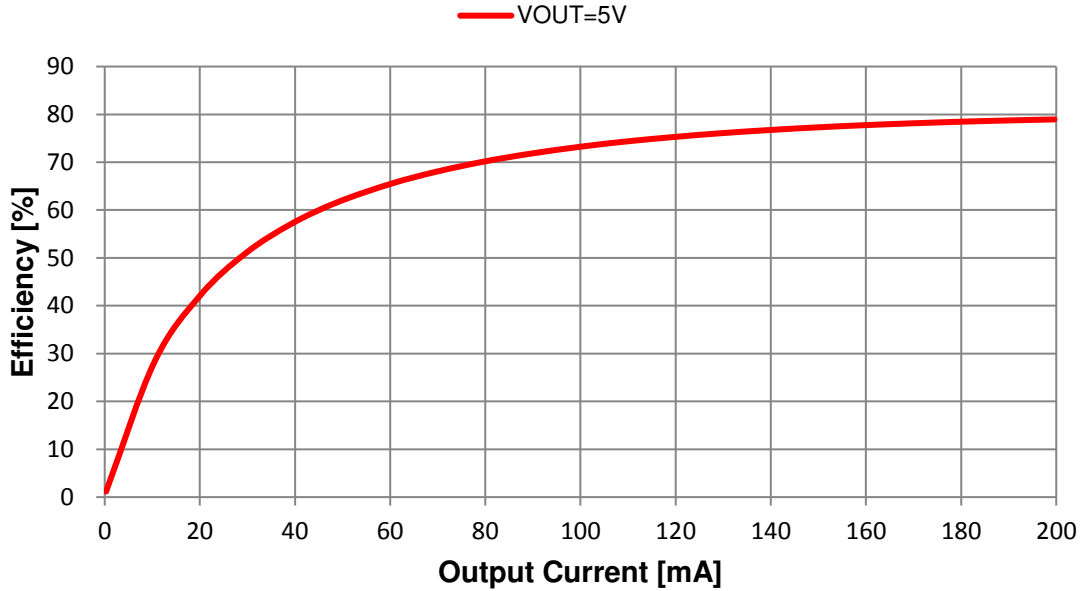

**177920511 Efficiency - Vin = 5V, T<sub>A</sub>=25°C**

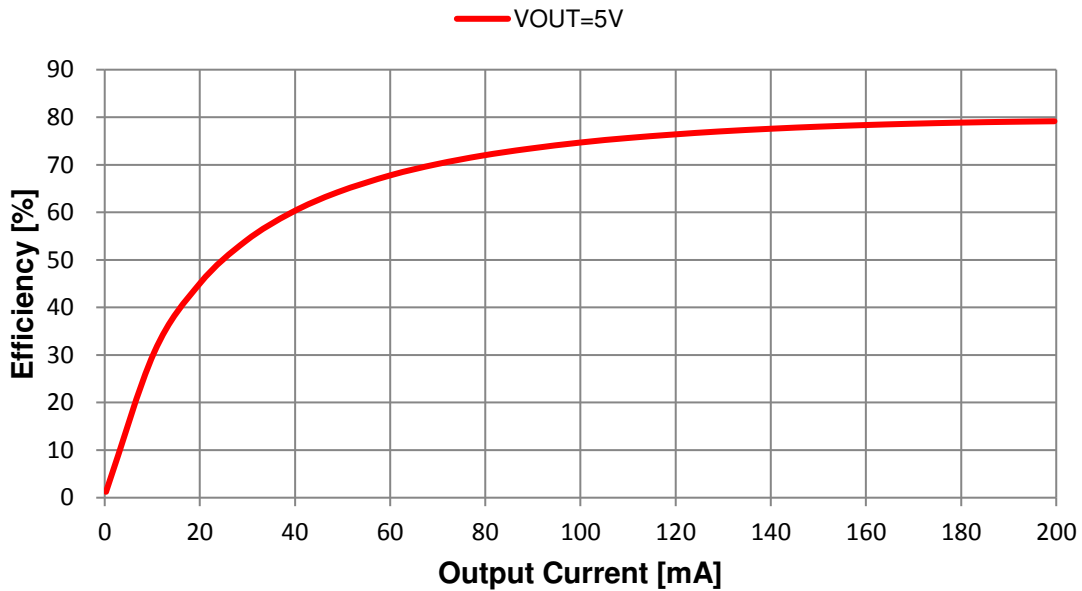

177920501, 177920511, 177920521, 177920531

**MagI<sup>3</sup>C** Power Module  
**FISM – Fixed Isolated SIP Module**



177920521 Efficiency -  $V_{in} = 12V$ ,  $T_A = 25^\circ C$

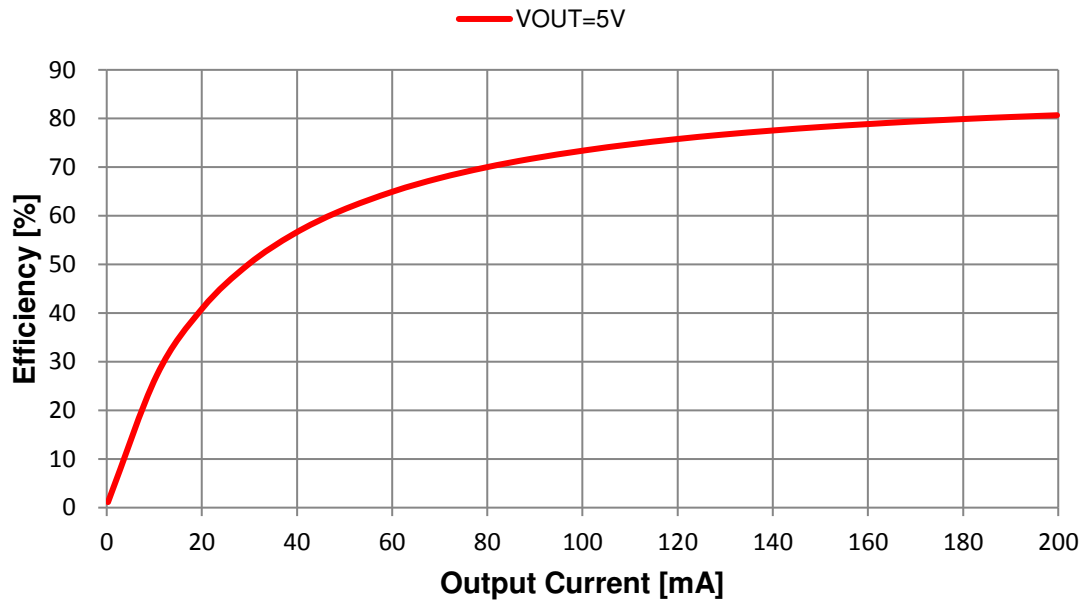

177920531 Efficiency -  $V_{IN} = 24V$ ,  $T_A = 25^\circ C$

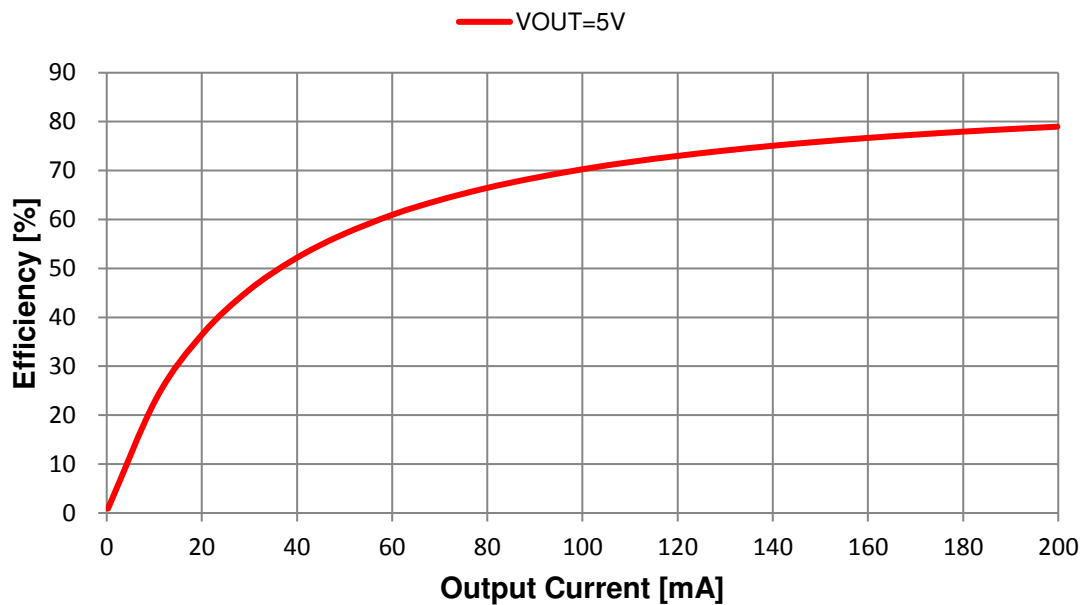

177920501, 177920511, 177920521, 177920531

**MagI<sup>3</sup>C** Power Module  
**FISM – Fixed Isolated SIP Module**



**OUTPUT POWER**

**Thermal Derating**

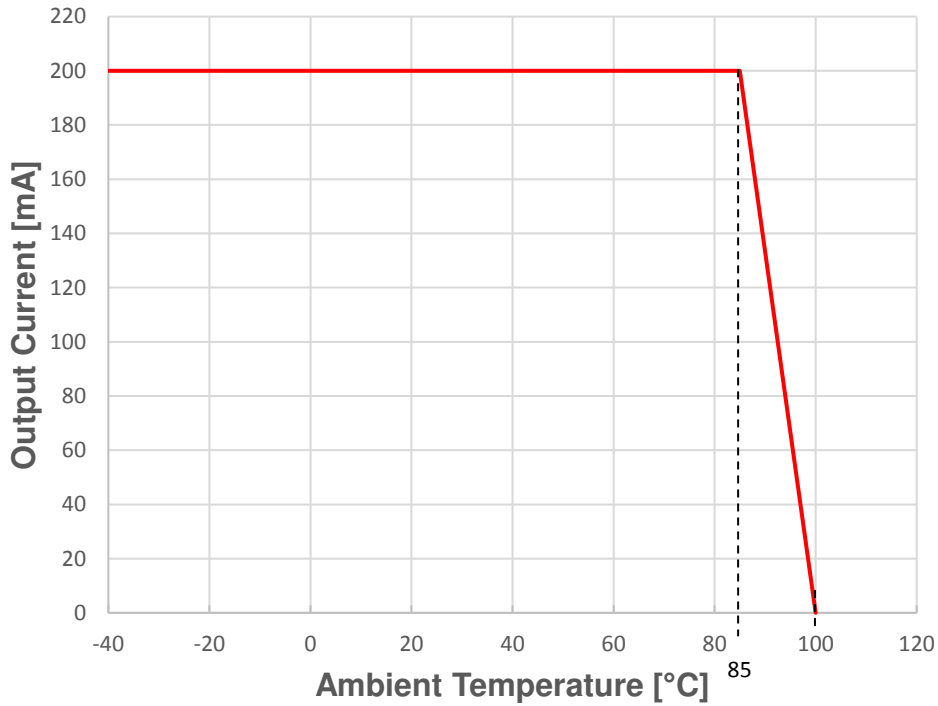

Note: Still air (0 – 20LFM / 0 – 0.1m/s)

**I<sub>MOC</sub> DUTY CYCLE**

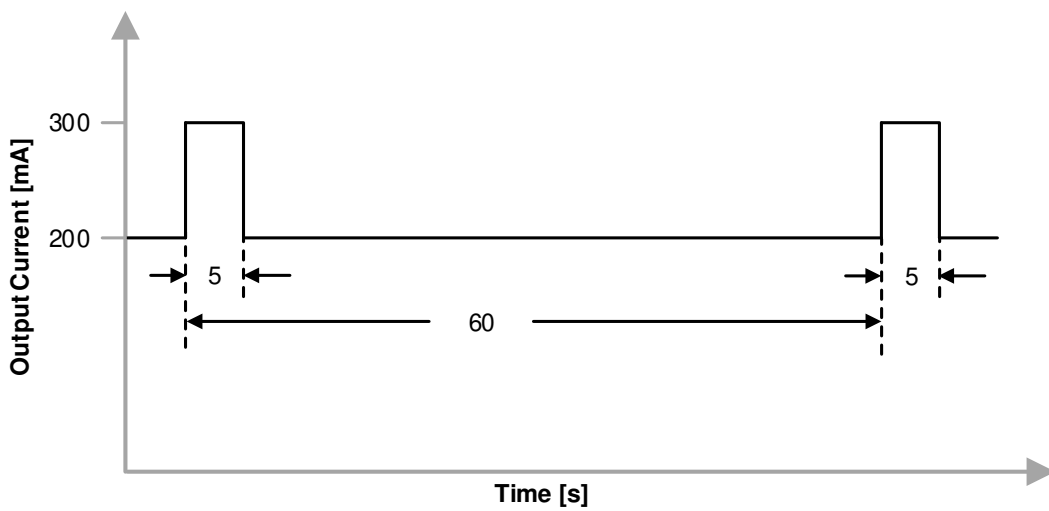

**Note:** The overload current of 300mA can be supplied for maximum 5s and requires a 55s recovery time till next overload event.

177920501, 177920511, 177920521, 177920531

**MagI<sup>3</sup>C** Power Module  
**FISM – Fixed Isolated SIP Module**



**I<sub>MOC</sub> TEMPERATURE DERATING**

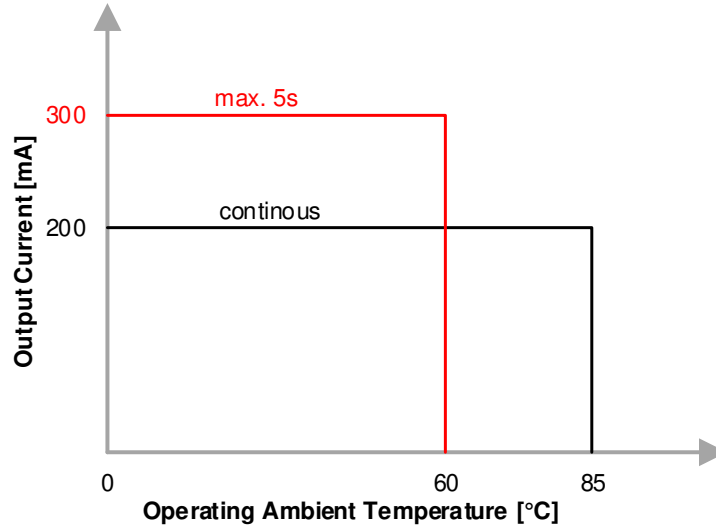

**Note:** Valid for still air (0 – 20LFM / 0 – 0.1m/s) / horizontal orientation

**OUTPUT VOLTAGE TOLERANCE ENVELOPE**

V<sub>IN</sub>=3.3V (177920501), 5V (177920511), 12V (177920521), 24V (177920531) V<sub>OUT</sub>=5V

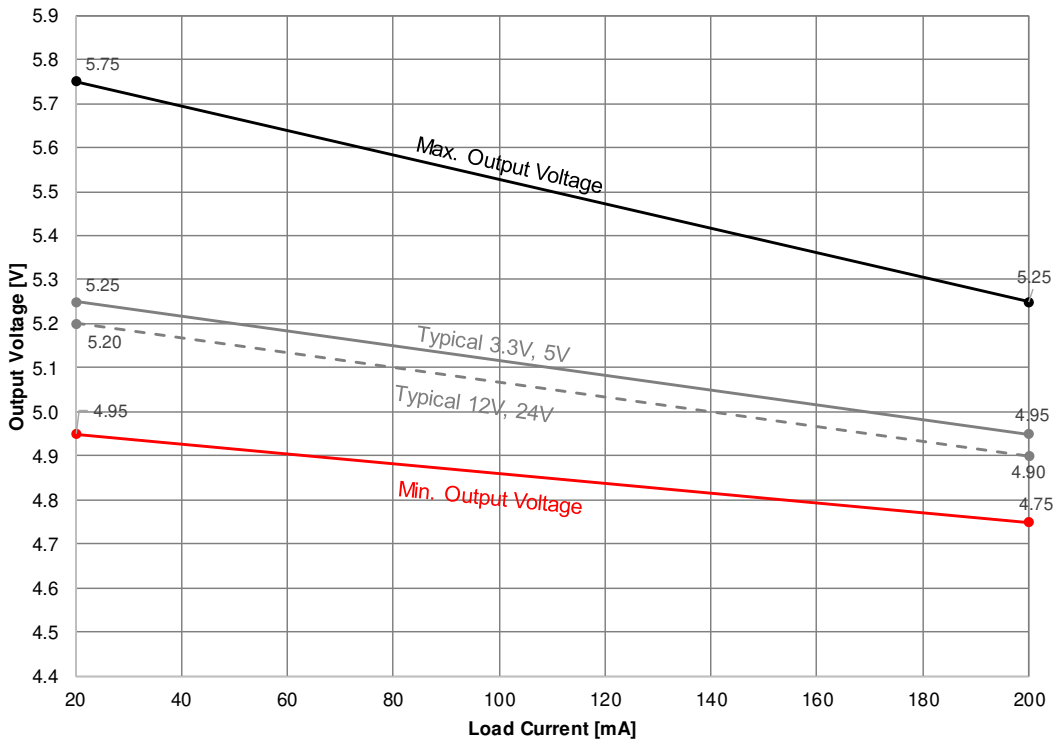

**Note:** Output voltage may exceed +25% of nominal output voltage at zero load.



177920501, 177920511, 177920521, 177920531

**MagI<sup>3</sup>C** Power Module  
**FISM** – Fixed Isolated SIP Module



## BLOCK DIAGRAM

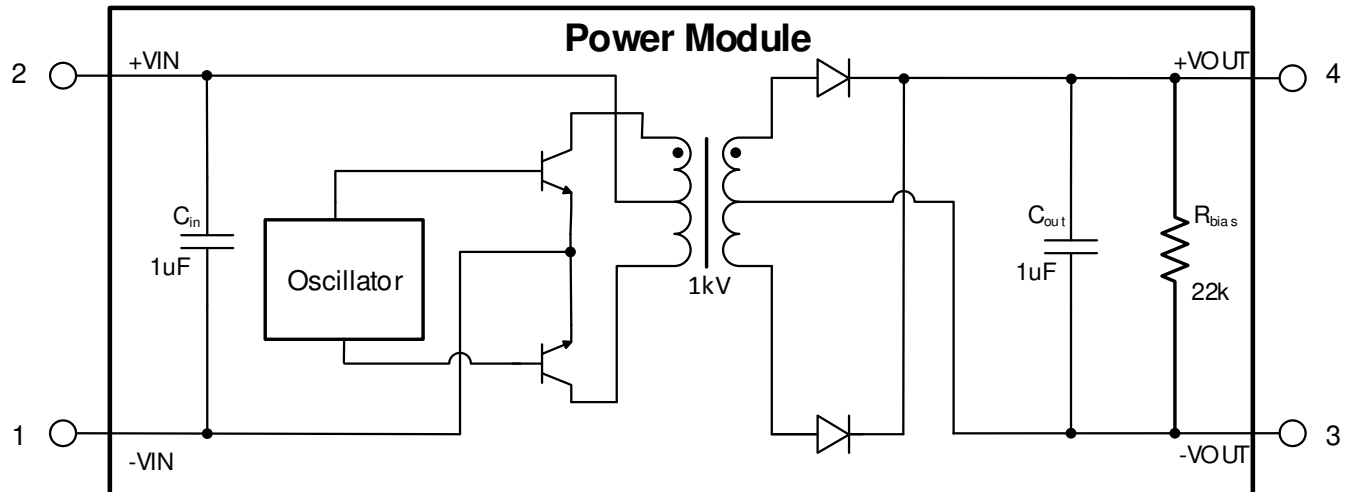

## CIRCUIT DESCRIPTION

The MagI<sup>3</sup>C Power Modules 1779205x1 are based on a push – pull converter with integrated transistors, rectifying diodes, isolated transformer, input and output capacitors. The output voltage is unregulated.

Since there is no feedback path from the output to the input, the duty cycle is fixed at 50%. The duty cycle is independent of the load (zero load to full load). The output voltage is defined by the turns ratio of the transformer.

## PROTECTIVE FEATURES

Due to the structure of the MagI<sup>3</sup>C power module following protective features are **NOT** implemented:

- Over temperature protection (OTP)
- Over current protection (OCP)
- Output overvoltage protection (OVP)
- Input overvoltage protection
- Short circuit protection (SCP)
- Input reverse polarity protection

**Note:** To protect the source and the MagI<sup>3</sup>C power module in abnormal conditions (secondary side overload or short circuit) a primary side input fuse of max. 1A (slow blow) is recommended.

177920501, 177920511, 177920521, 177920531

**MagI<sup>3</sup>C** Power Module  
**FISM – Fixed Isolated SIP Module**



## APPLICATION CONSIDERATIONS

### Filter Suggestion for Conducted and Radiated EMI

The input filter shown in the schematic below is recommended to achieve conducted and radiated EMI compliance according to EN55032 Class B (see results on pages 9 to 12).

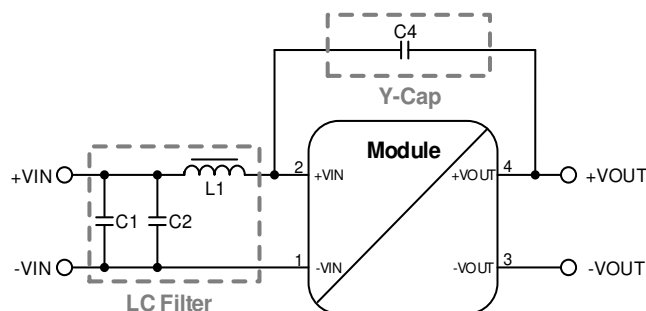

Component Values for Class B filters for the EN55032:

#### Input Voltage 3.3V:

DESIGNATOR	DESCRIPTION	FILTER	ORDER CODE	MANUFACTURER
C1	Filter ceramic chip capacitor 22 $\mu$ F/10V 1210 X7R	LC	885012209006	Würth Elektronik
L1	Filter inductor, 3.3 $\mu$ H, PD2 family		744773033	Würth Elektronik
C4	Filter ceramic chip capacitor 470pF/250Vac/2500V Impulse Voltage 1808 X7R	Y-Cap	885362210009	Würth Elektronik

#### Input Voltage 5V:

DESIGNATOR	DESCRIPTION	FILTER	ORDER CODE	MANUFACTURER
C1	Filter ceramic chip capacitor 10 $\mu$ F/25V 1210 X7R	LC	885012209028	Würth Elektronik
L1	Filter inductor, 4.7 $\mu$ H, PD2 family		744773047	Würth Elektronik
C4	Filter ceramic chip capacitor 470pF/250Vac/2500V Impulse Voltage 1808 X7R	Y-Cap	885362210009	Würth Elektronik

#### Input Voltage 12V:

DESIGNATOR	DESCRIPTION	FILTER	ORDER CODE	MANUFACTURER
C1	Filter ceramic chip capacitor 4.7 $\mu$ F/50V 1210 X7R	LC	885012209048	Würth Elektronik
L1	Filter inductor, 22 $\mu$ H, PD2 family		744773122	Würth Elektronik
C4	Filter ceramic chip capacitor 470pF/250Vac/2500V Impulse Voltage 1808 X7R	Y-Cap	885362210009	Würth Elektronik

177920501, 177920511, 177920521, 177920531

**MagI<sup>3</sup>C** Power Module  
**FISM** – Fixed Isolated SIP Module



Input Voltage 24V:

DESIGNATOR	DESCRIPTION	FILTER	ORDER CODE	MANUFACTURER
C1	Filter ceramic chip capacitor 4.7 $\mu$ F/50V 1210 X7R	LC	885012209048	Würth Elektronik
C2	Filter ceramic chip capacitor 4.7 $\mu$ F/50V 1210 X7R		885012209048	Würth Elektronik
L1	Filter inductor, 68 $\mu$ H, PD2 family		744773168	Würth Elektronik
C4	Filter ceramic chip capacitor 1000pF/250Vac/5000V Impulse Voltage 1808 X7R	Y-Cap	885352210013	Würth Elektronik

**Note:** C4 has to be rated to an impulse voltage equal or greater than the isolation voltage of the Power Module itself.

### Primary side parallel connection

A standard industrial configuration is, that the power modules are supplied by a dc bus voltage. When using multiple modules connected to a single rail the individual module inputs have to be decoupled by LC filters.

The LC filter reduces the likelihood of oscillations due to parasitics of a layout/routing. Therefore it is not recommended to connect power modules primary side parallel without an LC filter.

The outputs are not connected to each other and could have individual voltages  $V_{OUT1}$  and  $V_{OUT2}$ .

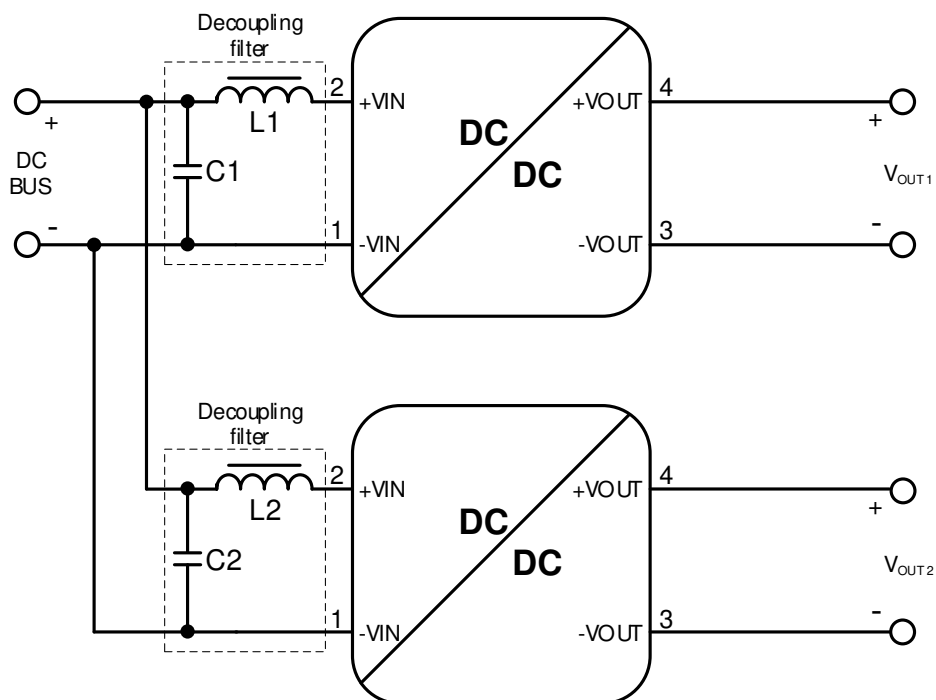

As a starting point for the decoupling filters, use the values of the reference filters – see also “[RADIATED AND CONDUCTED EMISSIONS \(WITH EMI INPUT FILTER\)](#)”. The final appropriate filter for the application has then to be evaluated under operation in the target application by checking e.g. the change of the input ripple voltage.

177920501, 177920511, 177920521, 177920531

**MagI<sup>3</sup>C** Power Module  
**FISM** – Fixed Isolated SIP Module



### Secondary side serial connection

To generate higher output voltage/special rail voltages it is possible to put the outputs of the 1779205X1 in series. It is common practice to connect an additional capacitor between the +VOUT and -VOUT.

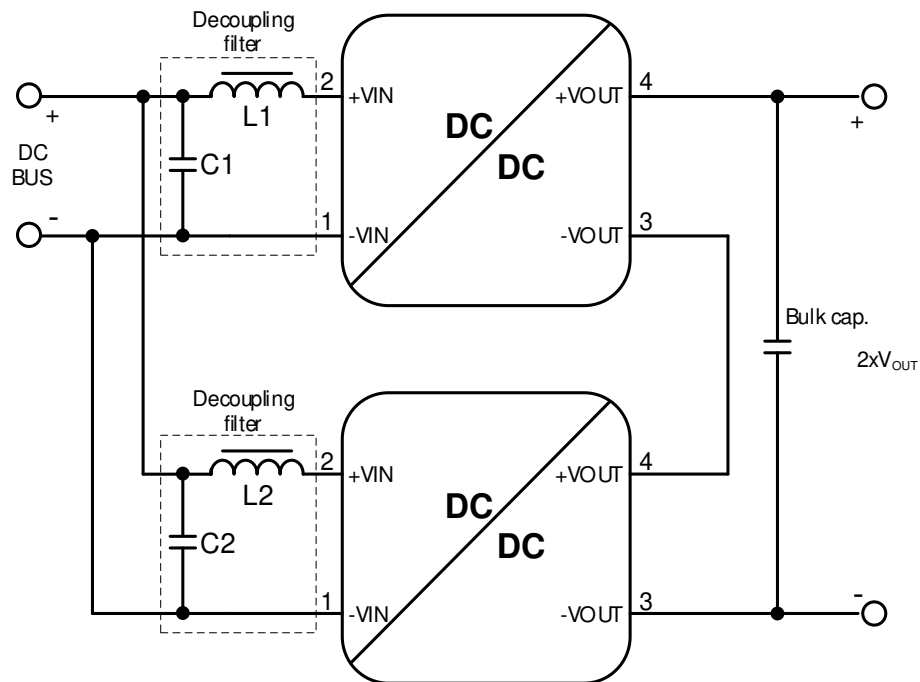

When using multiple modules connected to a single dc bus voltage the individual module inputs have to be decoupled by LC filters. The LC filter reduces the likelihood of oscillations due to parasitics of a layout/routing. Therefore, it is not recommended to connect power modules in parallel on the primary side without an LC filter. See also [Primary side parallel connection](#) on page 19

177920501, 177920511, 177920521, 177920531

**MagI<sup>3</sup>C** Power Module  
**FISM – Fixed Isolated SIP Module**



**Generating complementary output voltage**

Another common requirement in industrial application is to provide a complementary voltage (e.g.  $\pm 5V$ ). The circuit below shows how this target can be achieved simply combining a 1779205x1 used in a standard configuration (delivering a positive output voltage) with a 1779205x1 in reverse configuration. It is a common practice to connect an additional capacitor across each output voltage.

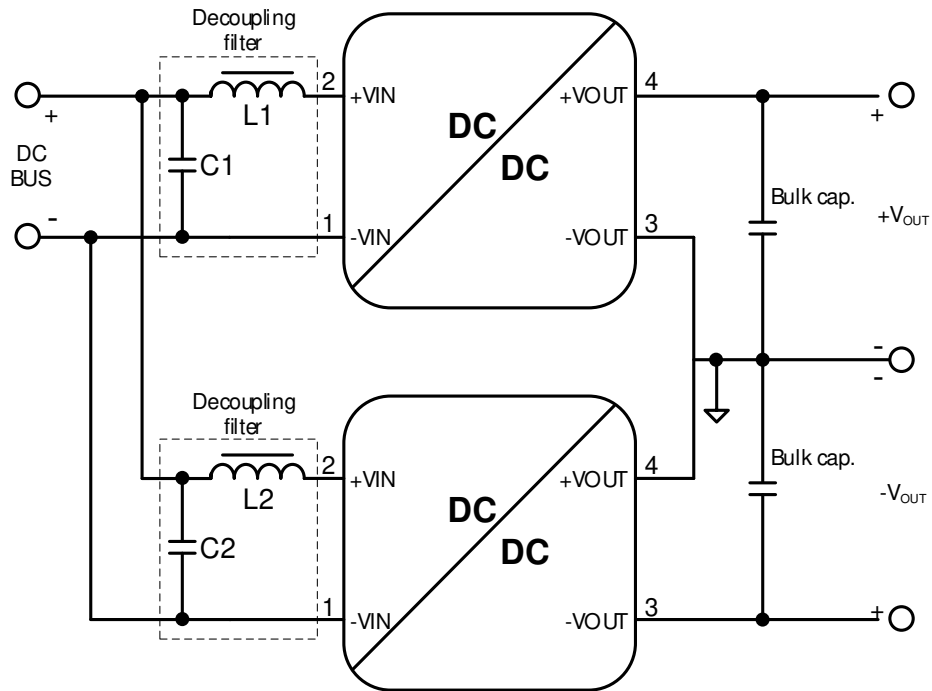

When using multiple modules connected to a single dc bus voltage, the individual module inputs have to be decoupled by LC filters. The LC filter reduces the likelihood of oscillations due to parasitics of a layout/routing. Therefore, it is not recommended to connect power modules in parallel on the primary side without an LC filter. See also [Primary side parallel connection](#) on page 19

**Note:** A decoupling filter is present to avoid oscillations between the two Power Modules. The decoupling filter doesn't replace the EMI input filter.

177920501, 177920511, 177920521, 177920531

**Magl<sup>3</sup>C** Power Module  
**FISM – Fixed Isolated SIP Module**



**PHYSICAL DIMENSIONS**

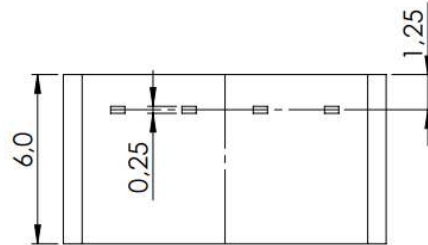
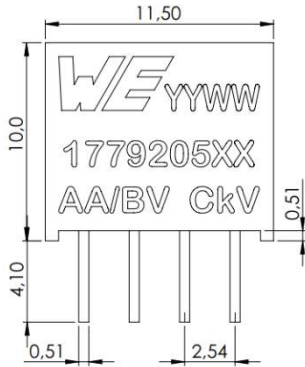

Tolerance: xx.x = ±0.5mm ; xx.xx = ±0.25mm

**RECOMMENDED DRILL HOLES**

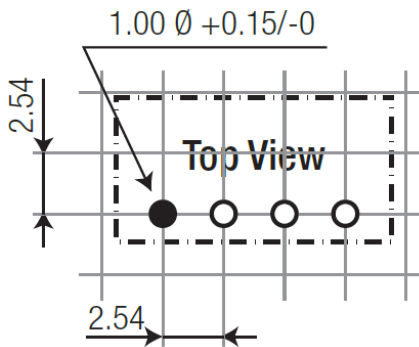

**TUBE**

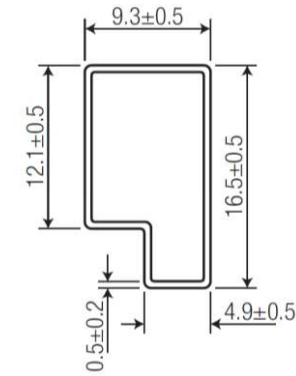

all dimensions in mm

**DOCUMENT HISTORY**

Revision	Date	Description	Comment
1.0	19.08.2016	Final version	
1.1	July.2018	Updated version released	<ul style="list-style-type: none"> <li>- UL status changed to final</li> <li>- Minor text layout changes</li> <li>- Add 60s value for V<sub>iso</sub></li> <li>- Add package specification section</li> <li>- Add primary side parallel connection &amp; filter suggestions</li> </ul>

177920501, 177920511, 177920521, 177920531

**MagI<sup>3</sup>C** Power Module  
**FISM – Fixed Isolated SIP Module**



## CAUTIONS AND WARNINGS

**The following conditions apply to all goods within the product series of MagI<sup>3</sup>C of Würth Elektronik eiSos GmbH & Co. KG:**

### General:

All recommendations according to the general technical specifications of the data-sheet have to be complied with.

The usage and operation of the product within ambient conditions which probably alloy or harm the component surface has to be avoided.

The responsibility for the applicability of customer specific products and use in a particular customer design is always within the authority of the customer. All technical specifications for standard products do also apply for customer specific products.

Residual washing varnish agent that is used during the production to clean the application might change the characteristics of the body, pins or termination. The washing varnish agent could have a negative effect on the long term function of the product.

Direct mechanical impact to the product shall be prevented as the material of the body, pins or termination could flake or in the worst case it could break. As these devices are sensitive to electrostatic discharge customer shall follow proper IC Handling Procedures.

Customer acknowledges and agrees that it is solely responsible for compliance with all legal, regulatory and safety-related requirements concerning its products, and any use of Würth Elektronik eiSos GmbH & Co. KG components in its applications, notwithstanding any applications-related information or support that may be provided by Würth Elektronik eiSos GmbH & Co. KG. Customer represents and agrees that it has all the necessary expertise to create and implement safeguards which anticipate dangerous consequences of failures, monitor failures and their consequences lessen the likelihood of failures that might cause harm and take appropriate remedial actions. Customer will fully indemnify Würth Elektronik eiSos and its representatives against any damages arising out of the use of any Würth Elektronik eiSos GmbH & Co. KG components in safety-critical applications.

### Product specific:

Follow all instructions mentioned in the datasheet, especially:

- The solder profile has to comply with the technical reflow or wave soldering specification, otherwise this will void the warranty.
- All products are supposed to be used before the end of the period of 12 months based on the product date-code.
- Violation of the technical product specifications such as exceeding the absolute maximum ratings will void the warranty.
- It is also recommended to return the body to the original moisture proof bag and reseal the moisture proof bag again.
- ESD prevention methods need to be followed for manual handling and processing by machinery.

177920501, 177920511, 177920521, 177920531

**MagI<sup>3</sup>C** Power Module  
**FISM – Fixed Isolated SIP Module**



## IMPORTANT NOTES

The following conditions apply to all goods within the product range of Würth Elektronik eiSos GmbH & Co. KG:

### 1. General Customer Responsibility

Some goods within the product range of Würth Elektronik eiSos GmbH & Co. KG contain statements regarding general suitability for certain application areas. These statements about suitability are based on our knowledge and experience of typical requirements concerning the areas, serve as general guidance and cannot be estimated as binding statements about the suitability for a customer application. The responsibility for the applicability and use in a particular customer design is always solely within the authority of the customer. Due to this fact it is up to the customer to evaluate, where appropriate to investigate and decide whether the device with the specific product characteristics described in the product specification is valid and suitable for the respective customer application or not. Accordingly, the customer is cautioned to verify that the datasheet is current before placing orders.

### 2. Customer Responsibility related to Specific, in particular Safety-Relevant Applications

It has to be clearly pointed out that the possibility of a malfunction of electronic components or failure before the end of the usual lifetime cannot be completely eliminated in the current state of the art, even if the products are operated within the range of the specifications. In certain customer applications requiring a very high level of safety and especially in customer applications in which the malfunction or failure of an electronic component could endanger human life or health it must be ensured by most advanced technological aid of suitable design of the customer application that no injury or damage is caused to third parties in the event of malfunction or failure of an electronic component.

### 3. Best Care and Attention

Any product-specific notes, warnings and cautions must be strictly observed.

### 4. Customer Support for Product Specifications

Some products within the product range may contain substances which are subject to restrictions in certain jurisdictions in order to serve specific technical requirements. Necessary information is available on request. In this case the field sales engineer or the internal sales person in charge should be contacted who will be happy to support in this matter.

### 5. Product R&D

Due to constant product improvement product specifications may change from time to time. As a standard reporting procedure of the Product Change Notification (PCN) according to the JEDEC-Standard we inform about minor and major changes. In case of further queries regarding the PCN, the field sales engineer or the internal sales person in charge should be contacted. The basic responsibility of the customer as per Section 1 and 2 remains unaffected.

### 6. Product Life Cycle

Due to technical progress and economical evaluation we also reserve the right to discontinue production and delivery of products. As a standard reporting procedure of the Product Termination Notification (PTN) according to the JEDEC-Standard we will inform at an early stage about inevitable product discontinuance. According to this we cannot guarantee that all products within our product range will always be available. Therefore it needs to be verified with the field sales engineer or the internal sales person in charge about the current product availability expectancy before or when the product for application design-in disposal is considered. The approach named above does not apply in the case of individual agreements deviating from the foregoing for customer-specific products.

### 7. Property Rights

All the rights for contractual products produced by Würth Elektronik eiSos GmbH & Co. KG on the basis of ideas, development contracts as well as models or templates that are subject to copyright, patent or commercial protection supplied to the customer will remain with Würth Elektronik eiSos GmbH & Co. KG. Würth Elektronik eiSos GmbH & Co. KG does not warrant or represent that any license, either expressed or implied, is granted under any patent right, copyright, mask work right, or other intellectual property right relating to any combination, application, or process in which Würth Elektronik eiSos GmbH & Co. KG components or services are used.

### 8. General Terms and Conditions

Unless otherwise agreed in individual contracts, all orders are subject to the current version of the "General Terms and Conditions of Würth Elektronik eiSos Group", last version available at [www.we-online.com](http://www.we-online.com).