

Features

- ESD Protection for 1 Line with Bi-directional
- Provide ESD protection for the protected line to IEC 61000-4-2 (ESD) $\pm 15\text{kV}$ (air), $\pm 10\text{kV}$ (contact)
- **Ultra low capacitance: 0.4pF typical**
- Suitable for, **17V and below**, operating voltage applications
- **0402 small DFN package** saves board space
- Protect one I/O line
- Fast turn-on and Low clamping voltage
- Solid-state silicon-avalanche and active circuit triggering technology
- **Green Part**

Applications

- Near Field Communication (NFC)
- RF Signal ESD Protection
- PA ESD Protection
- Antenna ESD Protection
- Hand Held Portable Applications

Description

AZ4617-01F is a design which includes a bi-directional ESD rated clamping cell to protect high speed data interfaces in an electronic systems. The AZ4617-01F has been specifically designed to protect sensitive components which are connected to data and transmission lines from over-voltage caused by Electrostatic Discharging (ESD).

AZ4617-01F is a unique design which includes proprietary clamping cells with ultra low capacitance in a small package. During transient conditions, the proprietary clamping cells prevent over-voltage on the control/data lines, protecting any downstream components.

AZ4617-01F is bi-directional and may be used on lines where the signal swings above and below ground.

AZ4617-01F may be used to meet the ESD immunity requirements of IEC 61000-4-2, Level 4 ($\pm 15\text{kV}$ air, $\pm 8\text{kV}$ contact discharge).

Circuit Diagram / Pin Configuration

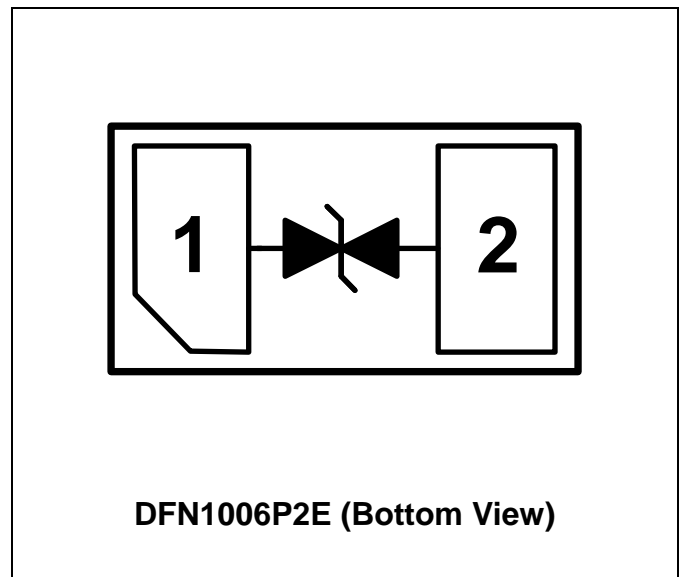



SPECIFICATIONS

ABSOLUTE MAXIMUM RATINGS			
PARAMETER	SYMBOL	RATING	UNITS
Operating DC Voltage (I/O to GND)	V_{DC}	±18	V
ESD per IEC 61000-4-2 (Air)	V_{ESD}	±15	kV
ESD per IEC 61000-4-2 (Contact)		±10	kV
Lead Soldering Temperature	T_{SOL}	260 (10 sec.)	°C
Operating Temperature	T_{OP}	-40 to +85	°C
Storage Temperature	T_{STO}	-55 to +150	°C

ELECTRICAL CHARACTERISTICS						
PARAMETER	SYMBOL	CONDITIONS	MINI	TYP	MAX	UNITS
Stand-Off Voltage	V_{RWM}	$T=25\text{ }^{\circ}\text{C}$, I/O to GND, or GND to I/O.			17	V
Leakage Current	I_{Leak}	$V_{RWM} = 17\text{V}$, $T=25\text{ }^{\circ}\text{C}$, I/O to GND, or GND to I/O.			0.5	μA
Breakdown Voltage	V_{BV}	$I_{BV} = 1\text{mA}$, $T=25\text{ }^{\circ}\text{C}$, I/O to GND, or GND to I/O.	18.7			V
ESD Clamping Voltage	V_{clamp}	IEC 61000-4-2, 6kV Contact mode, $T=25\text{ }^{\circ}\text{C}$, I/O to GND, or GND to I/O.		38		V
ESD Dynamic Turn-on Resistance	$R_{dynamic}$	IEC 61000-4-2, 0~6kV, Contact mode, $T=25\text{ }^{\circ}\text{C}$, I/O to GND, or GND to I/O.		1.0		Ω
Input Capacitance	C_{IN}	$V_R = 0\text{V}$, $f = 1\text{MHz}$, $T=25\text{ }^{\circ}\text{C}$, I/O to GND.		0.4	0.55	pF



Typical Characteristics

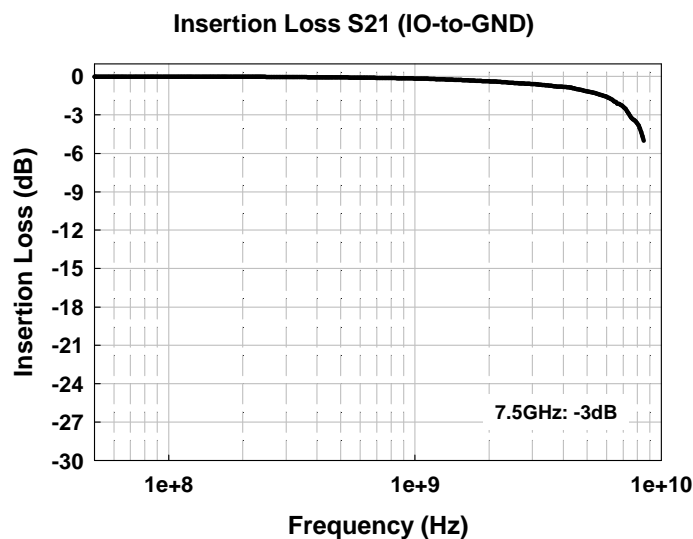
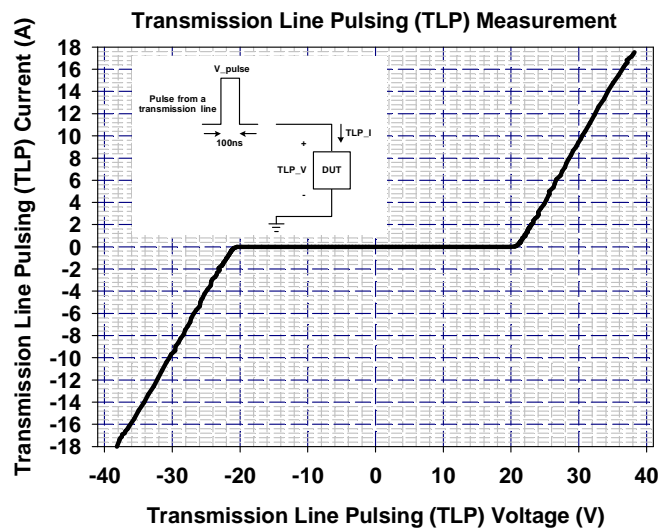
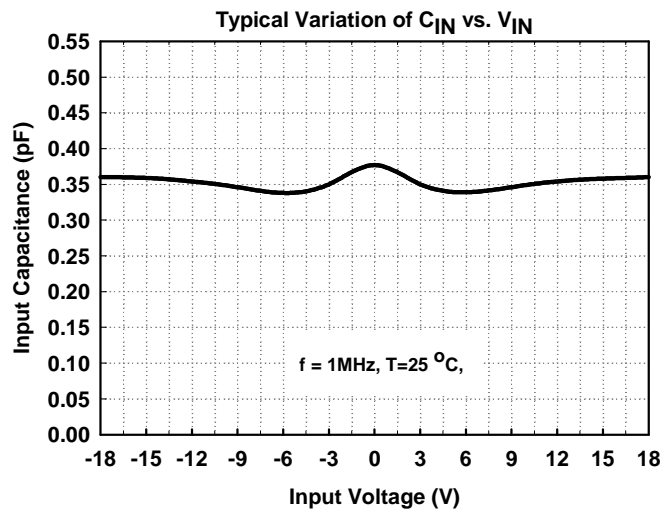

Applications Information

The AZ4617-01F is designed to protect one line against System ESD pulse by clamping it to an acceptable reference. It provides bi-directional protection.

The usage of the AZ4617-01F is shown in Fig. 1. Protected line, such as data line, control line, or power line, is connected at pin 1. The pin 2 is connected to a ground plane on the board. In order to minimize parasitic inductance in the board traces, all path lengths connected to the pins of AZ4617-01F should be kept as short as possible.

In order to obtain enough suppression of ESD induced transient, good circuit board is critical. Thus, the following guidelines are recommended:

- Minimize the path length between the protected lines and the AZ4617-01F.
- Place the AZ4617-01F near the input terminals or connectors to restrict transient coupling.
- The ESD current return path to ground should be kept as short as possible.
- Use ground planes whenever possible.
- NEVER route critical signals near board edges and near the lines which the ESD transient easily injects to.

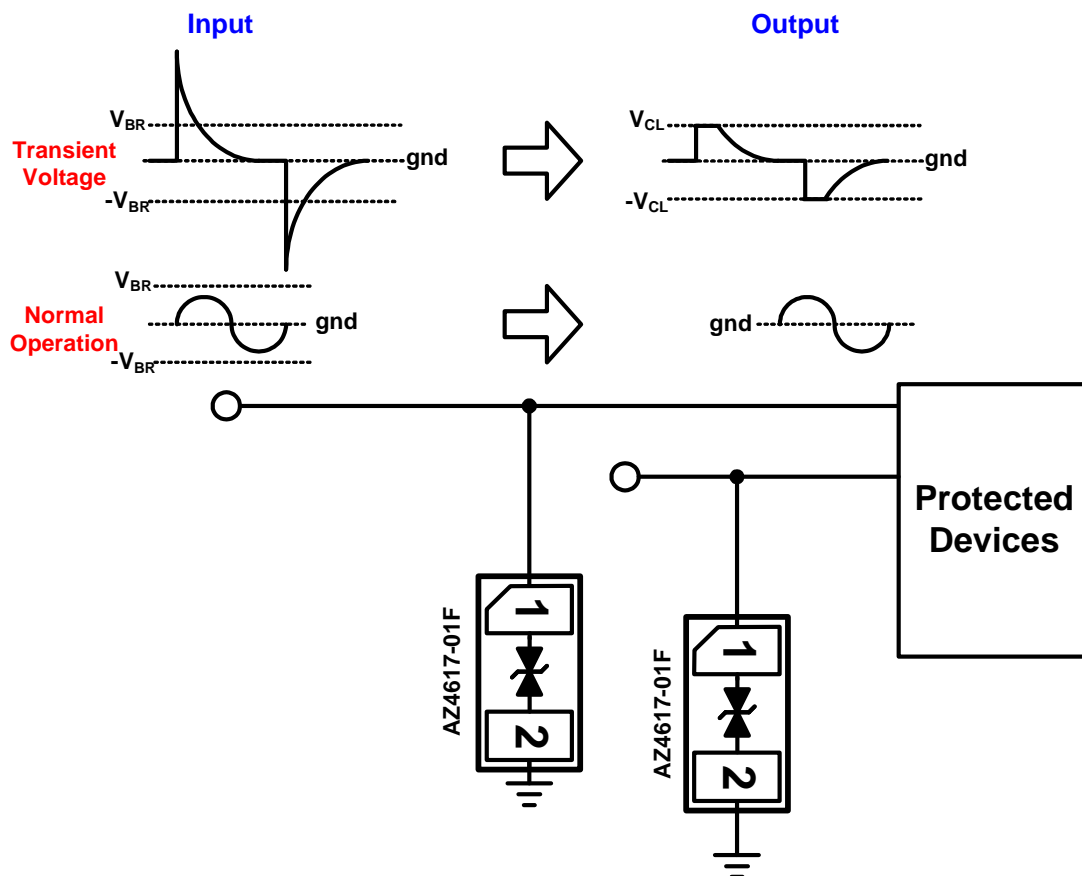

Fig. 1

Fig. 2 shows another simplified example of using AZ4617-01F to protect the control line, high speed data line, and power line from ESD transient stress.

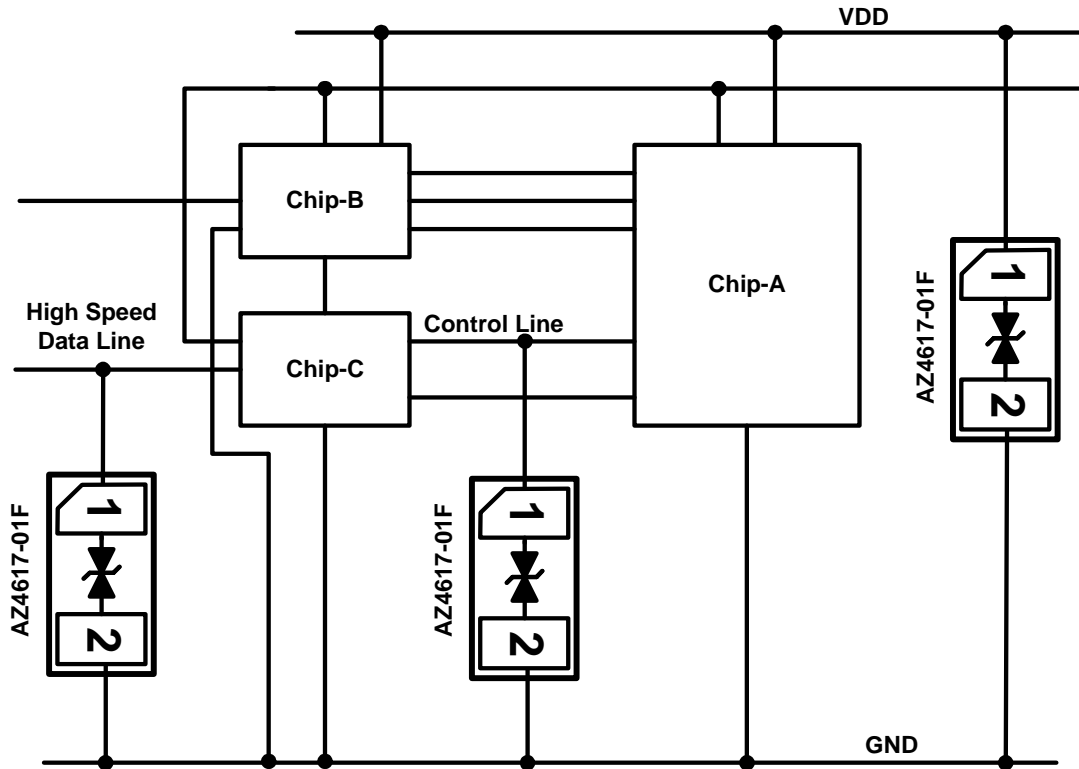
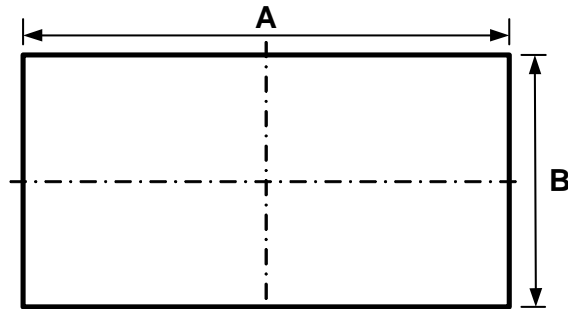

Fig. 2



Mechanical Details

DFN1006P2E PACKAGE DIAGRAMS



TOP VIEW



SIDE VIEW

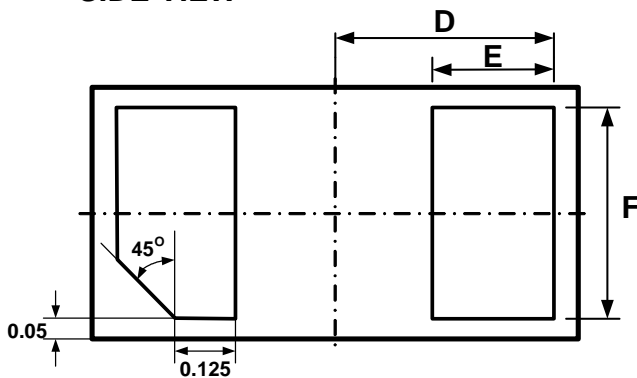

BOTTOM VIEW

LAND LAYOUT

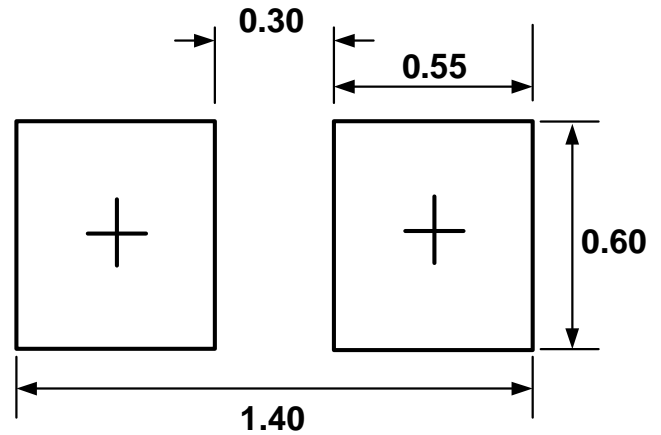

(Unit: mm)

Notes:

This LAND LAYOUT is for reference purposes only. Please consult your manufacturing partners to ensure your company's PCB design guidelines are met.

MARKING CODE

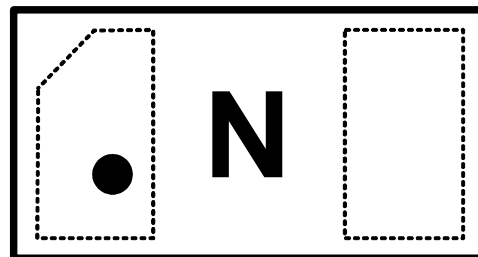

Top View

Symbol	Millimeters		Inches	
	min	max	min	max
A	0.95	1.05	0.037	0.041
B	0.55	0.65	0.022	0.026
C	0.45	0.60	0.018	0.024
D	0.45		0.018	
E	0.20	0.30	0.008	0.012
F	0.45	0.55	0.018	0.022

Part Number	Marking Code
AZ4617-01F (Green part)	N

Note. Green means Pb-free, RoHS, and Halogen free compliant.



Ordering Information

PN#	Material	Type	Reel size	MOQ	MOQ/internal box	MOQ/carton
AZ4617-01F.R7GR	Green	T/R	7 inch	12,000/reel	4 reel=48,000/box	6 box=288,000/carton

Revision History

Revision	Modification Description
Revision 2014/05/23	Preliminary Release.
Revision 2014/11/20	1. Add the characteristics of insertion loss S21. 2. Update the Ordering Information.
Revision 2015/01/30	Update the Ordering Information.
Revision 2015/06/30	Formal Release.