

Tous droits strictement réservés. Reproduction ou communication a des tiers interdite sous quelque forme que ce soit sans autorisation écrite du propriétaire. Propriété de c FCI. Droits de reproduction FCI.

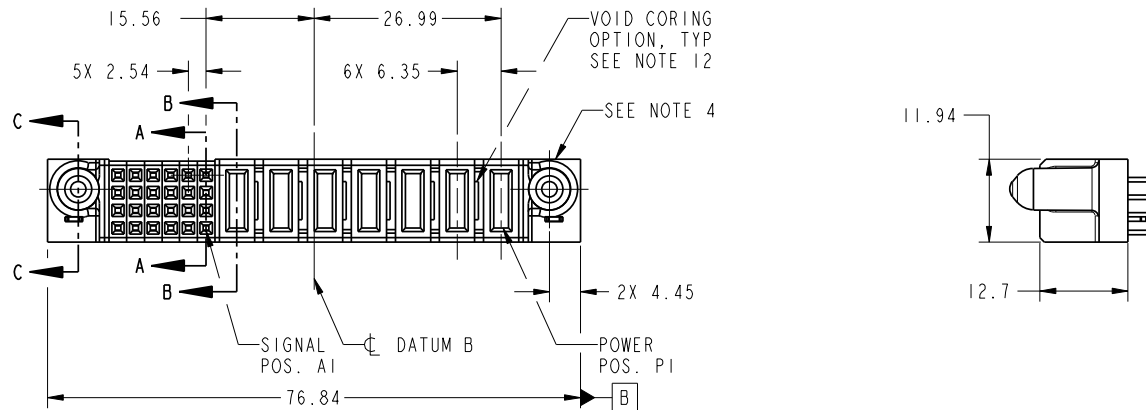

All rights strictly reserved. Reproduction or issue to third parties in any form whatever is not permitted without written authority from the proprietor. Property of FCI. Copyright FCI.

PRODUCT NO.	ROWS	SIGNAL					POWER					E1				
		E2	6	5	4	3	2	1	P7	P6	P5		P4	P3	P2	P1
51752-025-- NOTE: 3	D C B A		E	E	E	E	E	PA	PA	PA	PA	PA	PA	PA	PA	
		E	E	E	E	E	PA	PA	PA	PA	PA	PA	PA	PA	E	
		E	E	E	E	E	PA	PA	PA	PA	PA	PA	PA	PA	E	
		E	E	E	E	E	PA	PA	PA	PA	PA	PA	PA	PA	E	



CODE	DIM "M" MATING LENGTH	CONTACT TYPE
E	[N/A]	SIGNAL
PA	[1.07]	POWER
HA	[N/A]	HOLD-DOWN

mat'l code				tolerances unless otherwise specified		CUSTOMER	
lfr	ecn no.	dr	date	linear	0.X ± 0.5	FCI www.fciconnect.com	
A	DG08-0119	JC	05/20/08	linear	0.XX ± 0.25	projection	title
				angles	0.XXX ± 0.1		7P + 24S VERTICAL SOLDER RECEPT
				dr	0° ± 2°	MM	product family
				engr		1:1	PwrBlade
				chr			code
				appd			213
sheet index	revision sheet	A	A	A	A		sheet
		1	2	3	4		1 of 4



www.fciconnect.com

scale 1:1

size A

51752-025

cage code 22526

Pro/E

PDM: Rev:A

STATUS: Released

Printed: Dec 20, 2010

Tous droits strictement reserves. Reproduction ou communication a des tiers interdite sous quelque forme que ce soit sans autorisation écrite du propriétaire. Propriete de c FCI. Droits de reproduction FCI.



All rights strictly reserved. Reproduction or issue to third parties in any form whatever is not permitted without written authority from the proprietor. Property of FCI. Copyright FCI.

PRODUCT NUMBER
51752-025...
NOTE: 3

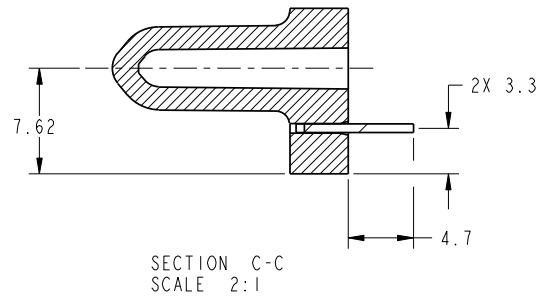
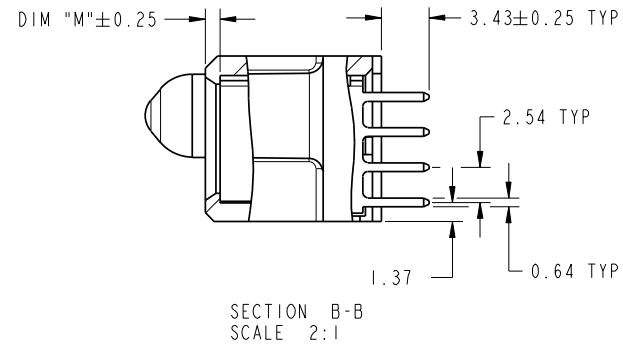
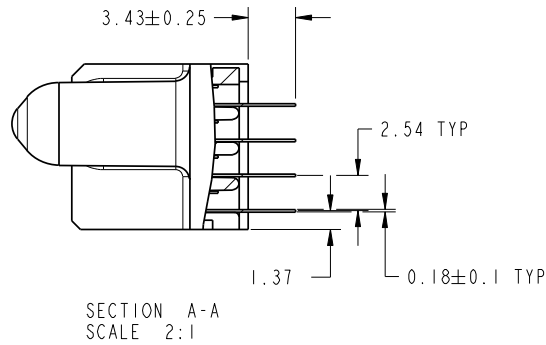

mat'l code				tolerances unless otherwise specified		CUSTOMER		FCI	
lfr	ecn no.	dr	date	linear	0.X ±0.5	COPY		www.fciconnect.com	
A				linear	0.XX ±0.25	projection	title		
				angles	0.XXX ±0.1		7P + 24S VERTICAL SOLDER RECEPT		
				angles	0° ±2°		product family	PwrBlade	code
				dr	Jerome Chen 04/17/08	MM	size	dwg no	213
				engr	Jerome Chen 04/17/08	1:1	A	51752-025	sheet
				chr	Gary Hsieh 04/17/08				2 of 4
				appd	Joseph Hsia 04/17/08				
sheet index	revision sheet								

Pro/E

cage code 22526

PDM: Rev:A

STATUS: Released

Printed: Dec 20, 2010

Tous droits strictement réservés. Reproduction ou communication o des liens interdite sous quelque forme que ce soit sans autorisation écrite du propriétaire. Propriete de c FCI. Droits de reproduction FCI.



All rights strictly reserved. Reproduction or issue to third parties in any form whatever is not permitted without written authority from the proprietor. Property of FCI. Copyright FCI.

PRODUCT NUMBER
51752-025..
NOTE: 3

NOTES:

1. DIMENSIONS AND TOLERANCES ARE IN ACCORDANCE WITH ASME Y14.5M, 1994 UNLESS OTHERWISE SPECIFIED.

CONNECTOR NOTES:

- 2 HOUSING MATERIAL: UL 94 V-0 GLASS FILLED HIGH-TEMP THERMOPLASTIC
POWER CONTACT MATERIAL: COPPER ALLOY
SIGNAL PIN MATERIAL: COPPER ALLOY
- 3. PLATING SPEC.
51752-025, 51752-025LF PLATING SPEC. WAS SHOWN IN THE PRINT OF 10064183.
- 4 MANUFACTURER'S NAME, P/N, AND DATE CODE TO APPEAR ON THIS SURFACE.
- 5. PRODUCT SPECIFICATION GS-12-149.
APPLICATION SPECIFICATION BUS-20-067.
- 6. PACKAGED IN TRAYS.

PCB NOTES:

- 7. ALL HOLE DIAMETERS ARE FINISHED HOLE SIZE.
- 8 MOUNTING HOLES, WHERE APPLICABLE, ARE UNPLATED.
- 9 $\varnothing 1.151 \pm 0.025$ DRILLED HOLES PLATED WITH 0.008 MIN SnPb OR Sn OVER 0.03 TO 0.08 Cu PLATING TO ACHIEVE $\varnothing 1.02 \pm 0.07$ HOLE.
- 10 "DIM XXX" TO BE DETERMINED BY THE CUSTOMER.
- 11 CONNECTOR KEEP-OUT ZONE.
- 12. THE VOID CORING IN BETWEEN POWER MODULES, SIGNAL MODULES AND END MODULES ARE OPTIONAL AND THE SHAPE MAY BE DIFFERENT FOR OPTIMIZE THE MOLDING PROCESS. THE VOID CORING WILL NOT EFFECT TO PRODUCT FUNCTION.

mat'l code				tolerances unless otherwise specified		CUSTOMER		FCI		www.fciconnect.com	
lfr	ecn no.	dr	date	linear	0.X ± 0.5	COPY		projection		title	
A					0.XX ± 0.25					7P + 24S VERTICAL SOLDER RECEPT	
				angles	0.XXX ± 0.1					product family PwrBlade code	
				dr	0° ± 2°			MM		size	
				engr	Jerome Chen 04/17/08			A		213	
				chr	Jerome Chen 04/17/08			scale		sheet	
				appd	Gary Hsieh 04/17/08			1:1		4 of 4	
					Joseph Hsia 04/17/08					cage code	
sheet index	revision sheet										

Pro/E

cage code 22526

PDM: Rev:A

STATUS: Released

Printed: Dec 20, 2010