

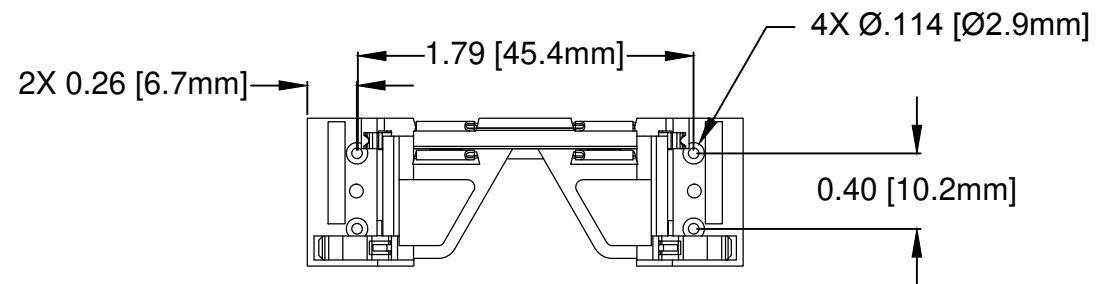

| ITEM | Q'TY | PART NUMBER | PART DESCRIPTION |
|------|------|-------------|--|
| 1 | 1 | CPCI-80 | 80mm Card Guide, Grey |
| 2 | X | CPCI-ESD1 | CPCI ESD Clips, PCB Grounding, SEE SHEET 2 TABLE 1 |
| 3 | X | CPCI-ESD2 | CPCI ESD Clips, Extractor Grounding, SEE SHEET 2 TABLE 1 |

| REV. | DESCRIPTION | DATE | APPROVED |
|------|----------------------|----------|----------|
| B | Engineering Release. | 11/20/14 | J. C. |
| | | | |
| | | | |
| | | | |

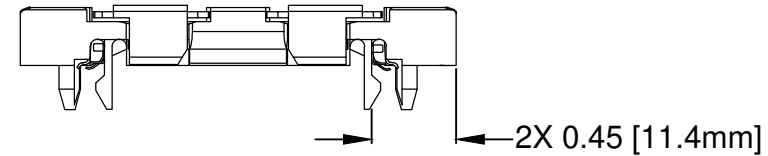
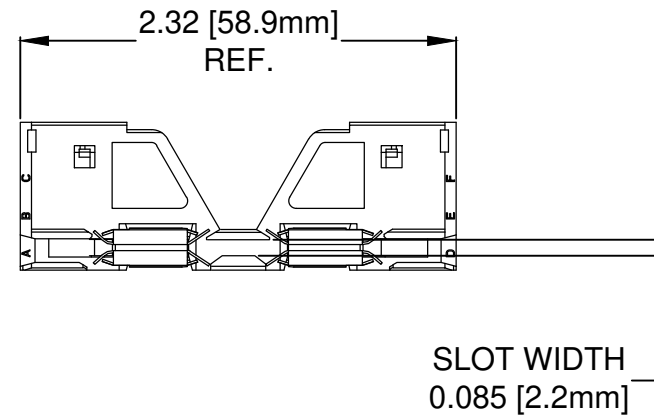
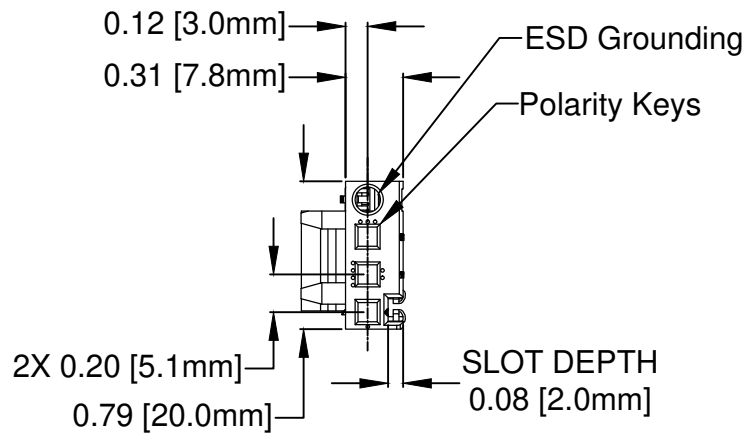

2. MATERIAL: POLYCARBONATE, 20% GLASS FILLED

1. GENERAL SPECIFICATIONS: BIVAR MOLDED COMPONENT SPECIFICATION BV00-E101.

| | | | |
|--|--------------------------|---|--|
| STANDARD TOLERANCE (UNLESS OTHERWISE SPECIFIED) | |  BIVAR [®] 4 THOMAS, IRVINE, CA 92618 TEL: (949) 951-8808 FAX: (949) 951-3974 | |
| DECIMALS | ANGULAR | | |
| .X ±.1 | X° ± 1° | TITLE: 80mm CPCI CARD GUIDE WITH ESD CLIPS PART NO: CPCI-80-ESDXX REVISION: B | |
| .XX ±.01 | | | |
| .XXX ±.005 | | | |
| DESIGNED: Alex Wright | DATE: 08/21/14 | CAGE CODE : 32559 SHEET # 1 OF 2 | |
| CHECKED: Brian Oliver | DATE: 08/21/14 | CAD GENERATED DOCUMENT, DO NOT MEASURE DRAWING. | |

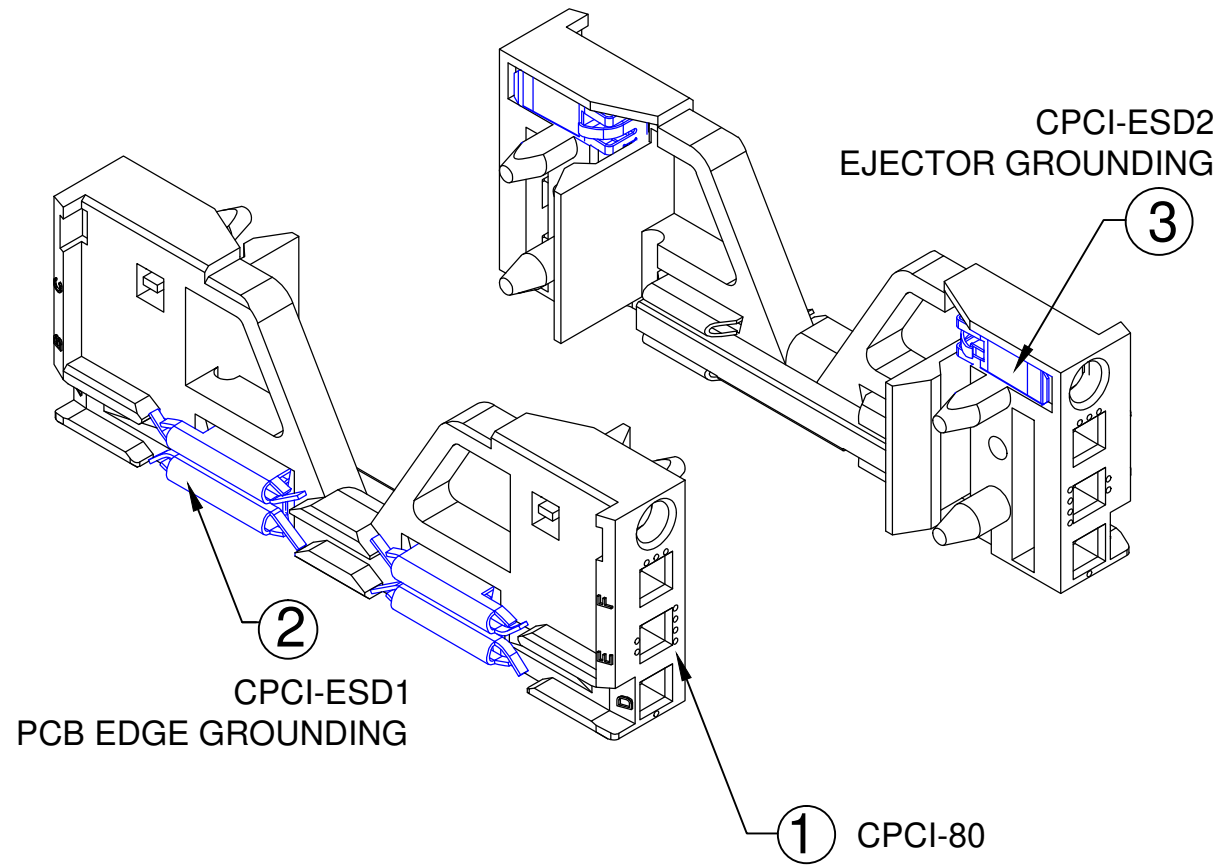

| REV. | DESCRIPTION | DATE | APPROVED |
|------|--------------|------|----------|
| | SEE SHEET #1 | | |
| | | | |
| | | | |
| | | | |



**TABLE 1
ASSEMBLY CONFIGURATIONS**

| ASSEMBLY PART NUMBERS | ITEM | QTY | | |
|-----------------------|------|-----|---|---|
| CPCI-80-ESD1 | 2 | 2 | | |
| CPCI-80-ESD2 | 3 | 2 | | |
| CPCI-80-ESD12 | 2 | 3 | 2 | 2 |

NOTE: ESD CLIPS COME PRE-ASSEMBLED

| | | | |
|--|--------------------------|--|-----------------------|
| STANDARD TOLERANCE (UNLESS OTHERWISE SPECIFIED) | |  4 THOMAS, IRVINE, CA 92618 TEL: (949) 951-8808 FAX: (949) 951-3974 | |
| DECIMALS | ANGULAR | | |
| .X ± .1 | X° ± 1° | | |
| .XX ± .01 | |  TITLE: 80mm CPCI CARD GUIDE WITH ESD CLIPS | |
| .XXX ± .005 | | | |
| DESIGNED: Alex Wright | DATE: 08/21/14 | PART NO: CPCI-80-ESDXX | REVISION: B |
| CHECKED: Brian Oliver | DATE: 08/21/14 | CAGE CODE : 32559 | SHEET # 2 OF 2 |
| CAD GENERATED DOCUMENT, DO NOT MEASURE DRAWING. | | | |