

HFD3023-500 Series Fiber Optic TTL Detector

Fiber Optic Components

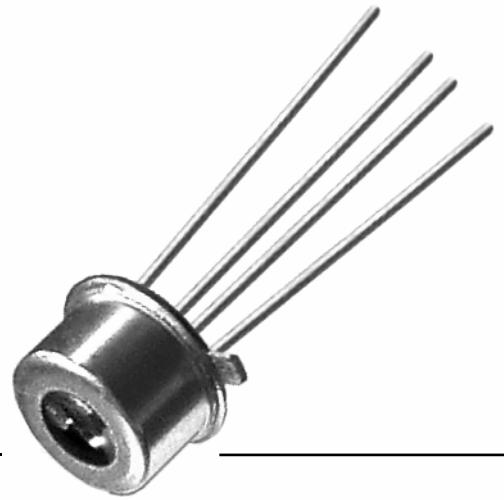

The HFD3023-500 Series is a direct coupled optical receiver designed for use in short distance 850 nm fiber optic systems. The receiver contains a monolithic IC (Integrated Circuit) with an integral photodiode and amplification circuit, and an open collector Schottky output. The output allows it to be directly interfaced with standard TTL (Transistor-Transistor Logic) circuits.

The HFD3023-500 Series converts the optical signal in a point-to-point data communications fiber optic link to a TTL output. The 0.006 in photodiode with a 0.024 in microlens (to enhance the optics) is mechanically centered within the TO46 package.

Electrical isolation is important in obtaining the maximum performance. A 0.1 μ F bypass capacitor must be connected between Vcc and ground. This minimizes power supply noise, increasing the signal quality. Shielding can also reduce coupled noise through use of ground plane PCB, shielding around the device and shielding around the leads.

FEATURES

- Converts fiber optic signals to TTL digital outputs
- Typical sensitivity 2 μ W (-27 dBm)
- High reliability
- Hermetic package, TO46
- Integral microlens for efficient fiber coupling

Optical power from the fiber strikes the photodiode and is converted to electrical current. This current couples to the dc amplifier, which drives an open collector transistor output. The output, when connected to a pull up resistor, can interface to TTL loads. The electrical signal is the inverse of the input light signal. When light strikes the photodiode, the output is a low logic level. When no light strikes the photodiode, the output is a high logic level.

Pulse Width Distortion (PWD) is an increase in the output pulse width (for high level optical input). The typical performance curves illustrate how PWD varies with optical power, temperature and frequency. The amount of PWD that a given system can tolerate without an error due to a missing bit of information is dependent upon system considerations. The output of the HFD3023 will typically connect to the input of some form of a serial interface adaptor IC. The specifications for that IC govern the amount of PWD that can be tolerated in the system.

The HFD3023-500 Series is the suggested replacement for Honeywell's HFD3023-002 Series.

TYPICAL APPLICATIONS

- Data communications
- CCTV systems
- Machine tools
- Controls/drives
- Packaging, converting and food processing machines

HFD3023-500 Series

ABSOLUTE MAXIMUM RATINGS

Storage temp.	-55 °C to 125 °C [-67 °F to 257 °F]
Case operating temp.	-40 °C to 85 °C [-40 °F to 185 °F]
Lead solder temp.	260 °C, 10 s
Supply voltage	+6 V

RECOMMENDED OPERATING CONDITIONS

Supply voltage	+4.5 V to +5.5 V
Optical input power	3 μW to 100 μW
Optical signal pulse width	<100 ns
Optical signal edges	<20 ns

CAUTION

PRODUCT DAMAGE

The inherent design of this component causes it to be sensitive to electrostatic discharge (ESD). To prevent ESD-induced damage and/or degradation to equipment, take normal ESD precautions when handling this product.

Failure to comply with these instructions may result in product damage.

ELECTRO-OPTICAL CHARACTERISTICS (Case T = 25 °C [77 °F])

Parameter	Test Condition	Symbol	Min.	Typical	Max.	Unit
High level logic output voltage	$P_{in} \leq 0.1 \mu W$, $R_L = 560 \Omega$	V_{OH}	2.4	4.5	—	V
Low level logic output voltage	$P_{in} \geq 3 \mu W$, $R_L = 560 \Omega$	V_{OL}	—	0.25	0.5	V
Supply current 1	$P_{in} \geq 3 \mu W$	I_{CC1}	—	13	15	mA
Supply current 2	$P_{in} \leq 0.1 \mu W$	I_{CC2}	—	4.5	6.5	mA
Minimum input sensitivity	$\lambda = 850 \text{ nm}$ into 100/140 μm optical fiber $f = 2.5 \text{ MHz}$, 50 % dc, PWD < 10%	$P_{in (peak)}$	—	2.0	3.0	μW
Response time	10 % - 90 %, $P_{in} \leq 10 \mu W$ $V_o = 0.5 \text{ V}$ to 2.4 V, $R_L = 560 \Omega$	t_r	—	6	9	ns
		t_f	—	6	9	ns
Pulse width distortion	$f = 2.5 \text{ MHz}$, DC = 50 % $P_{in} = 3 \mu W$ peak, $P_{in} = 80 \mu W$ peak	PWD	—	5	10	%
			—	25	25	%

FIGURE 1. BLOCK DIAGRAM

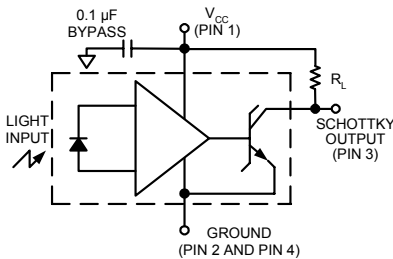

FIGURE 2. SWITCHING WAVEFORM

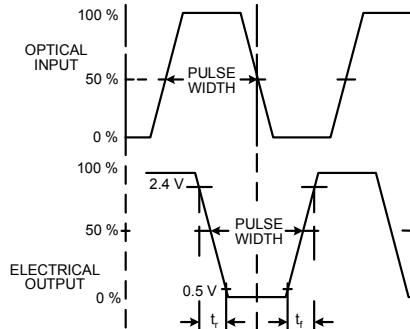

FIGURE 3. PULSE WIDTH DISTORTION VS OPTICAL INPUT POWER

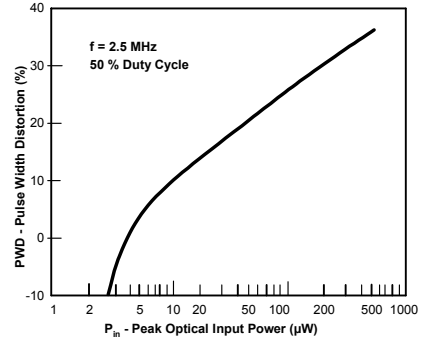

FIGURE 4. PULSE WIDTH DISTORTION VS TEMPERATURE

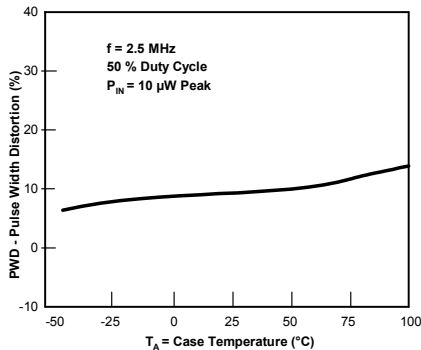

FIGURE 5. PULSE WIDTH DISTORTION VS FREQUENCY

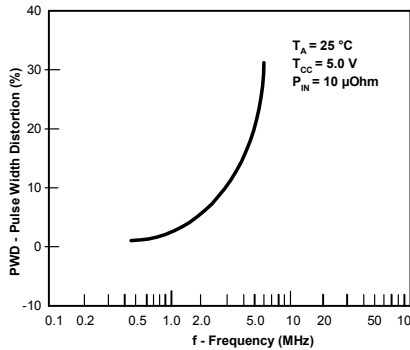
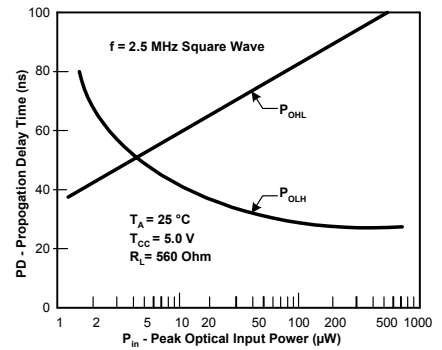

FIGURE 6. PROPAGATION DELAY TIME VS PEAK OPTICAL INPUT POWER



Fiber Optic Components

DIMENSIONS (For reference only (mm/[in]))

FIGURE 7. HFD3023-500

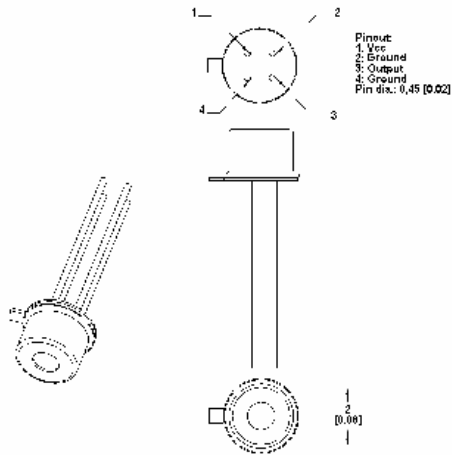

FIGURE 8. HFD3023-500-ADA (SMA 4 Hole)

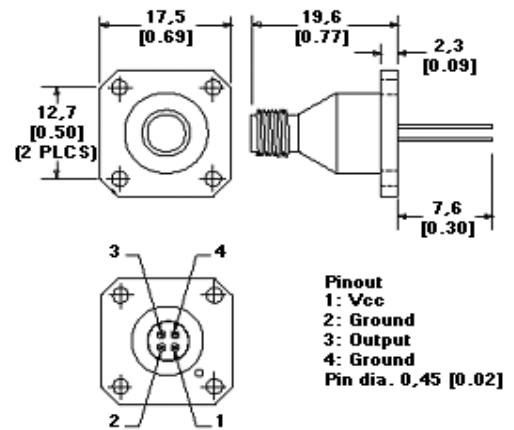

FIGURE 9. HFD3023-500-AAA (SMA Single Hole)

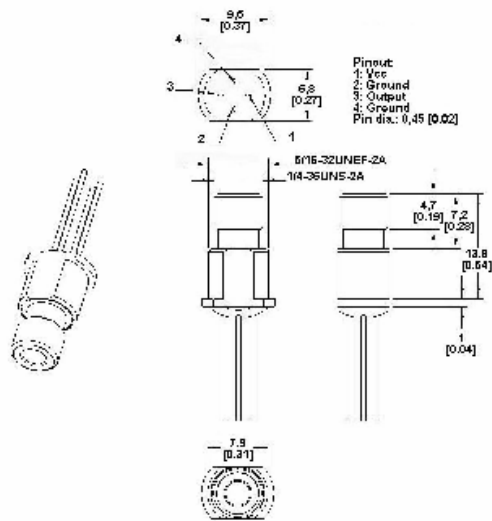

FIGURE 10. HFD3023-500-BAA (ST Single Hole)

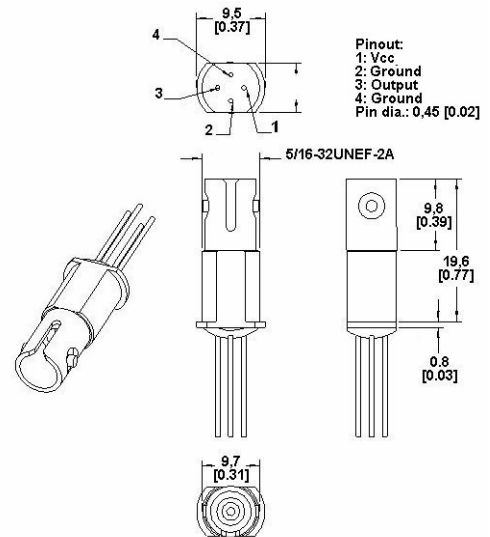

FIGURE 11. HFD3023-500-ABA (SMA PCB)

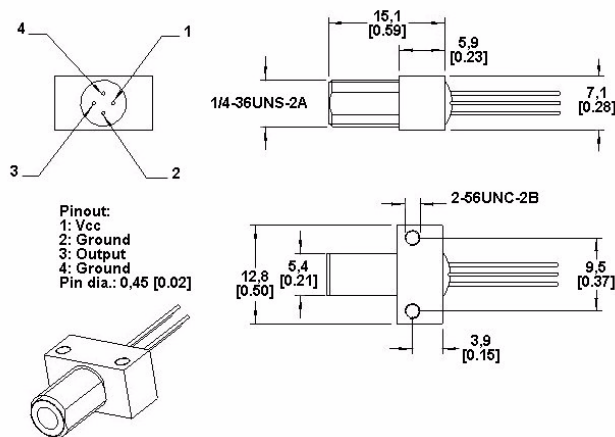
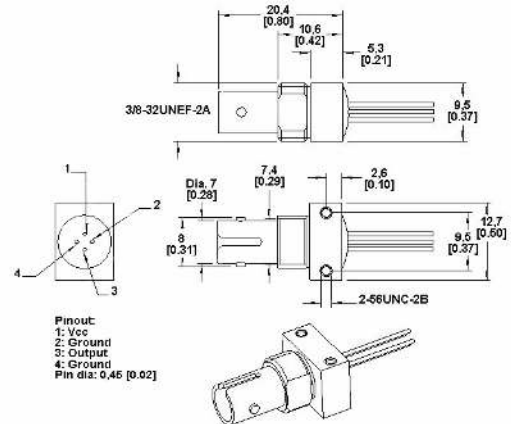

FIGURE 12. HFD3023-500-BBA (ST PCB)



ORDER GUIDE

Catalog Listing	Description
HFD3023-500	5 Mb direct coupled receiver
HFD3023-500-AAA	5 Mb direct coupled receiver (SMA single hole)
HFD3023-500-ABA	5 Mb direct coupled receiver (SMA PCB mount)
HFD3023-500-ADA	5 Mb direct coupled receiver (SMA 4 hole)
HFD3023-500-BAA	5 Mb direct coupled receiver (ST single hole)
HFD3023-500-BBA	5 Mb direct coupled receiver (ST PCB mount)

NOTICE

FIBER INTERFACE

Honeywell detectors are designed to interface with multimode fibers with sizes (core/cladding diameters) ranging from 50/125 microns to 200/230 microns. Honeywell performs final tests using 100/140 micron core fiber. The fiber chosen by the end user will depend upon a number of application issues (distance, link budget, cable attenuation, splice attenuation and safety margin.) The 50/125 micron and 62.5/125 micron fibers have the advantages of high bandwidth and low cost, making them ideal for higher bandwidth installations. The use of 100/140 micron and 200/230 micron core fibers results in greater power being coupled by the transmitter, making it easier to splice or connect in bulkhead areas. Optical cables can be purchased from a number of sources.

WARRANTY/REMEDY

Honeywell warrants goods of its manufacture as being free of defective materials and faulty workmanship. Honeywell's standard product warranty applies unless agreed to otherwise by Honeywell in writing; please refer to your order acknowledgement or consult your local sales office for specific warranty details. If warranted goods are returned to Honeywell during the period of coverage, Honeywell will repair or replace, at its option, without charge those items it finds defective. **The foregoing is buyer's sole remedy and is in lieu of all other warranties, expressed or implied, including those of merchantability and fitness for a particular purpose. In no event shall Honeywell be liable for consequential, special, or indirect damages.**

While we provide application assistance personally, through our literature and the Honeywell web site, it is up to the customer to determine the suitability of the product in the application.

Specifications may change without notice. The information we supply is believed to be accurate and reliable as of this printing. However, we assume no responsibility for its use.

Automation and Control Solutions

Sensing and Control

Honeywell

11 West Spring Street

Freeport, Illinois 61032

www.honeywell.com/sensing

WARNING

PERSONAL INJURY

DO NOT USE these products as safety or emergency stop devices or in any other application where failure of the product could result in personal injury.

Failure to comply with these instructions could result in death or serious injury.

WARNING

MISUSE OF DOCUMENTATION

- The information presented in this product sheet is for reference only. Do not use this document as a product installation guide.
- Complete installation, operation, and maintenance information is provided in the instructions supplied with each product.

Failure to comply with these instructions could result in death or serious injury.

SALES AND SERVICE

Honeywell serves its customers through a worldwide network of sales offices, representatives and distributors. For application assistance, current specifications, pricing or name of the nearest Authorized Distributor, contact your local sales office or:

E-mail: info.sc@honeywell.com

Internet: www.honeywell.com/sensing

Phone and Fax:

Asia Pacific +65 6355-2828
+65 6445-3033 Fax
Europe +44 (0) 1698 481481
+44 (0) 1698 481676 Fax
Latin America +1-305-805-8188
+1-305-883-8257 Fax
USA/Canada +1-800-537-6945
+1-815-235-6847
+1-815-235-6545 Fax

Honeywell