

REV.	DATE	ECR NO.	DESCRIPTION
NC	05/07/00	XXXXXX	INITIAL RELEASE
A	10/18/06	XXXXXX	UPDATE DRAWING FORMAT
B	08/31/11	2221	CHANGE THE CONTACT'S PLATING AND ADD THE ELECTRICAL SPECS.

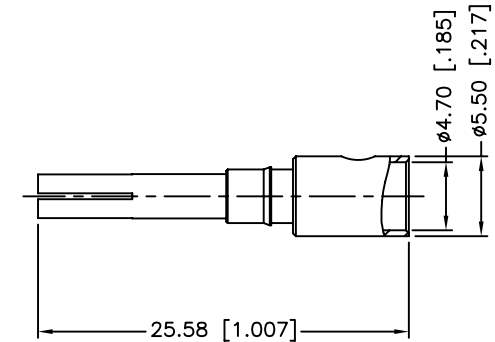
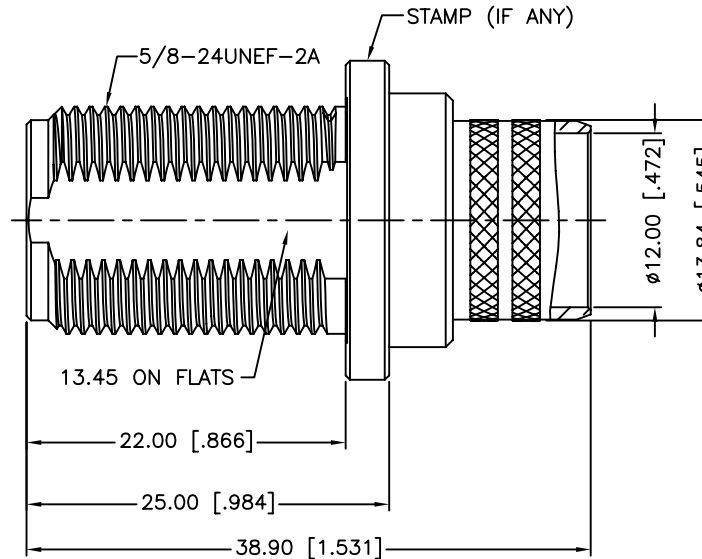
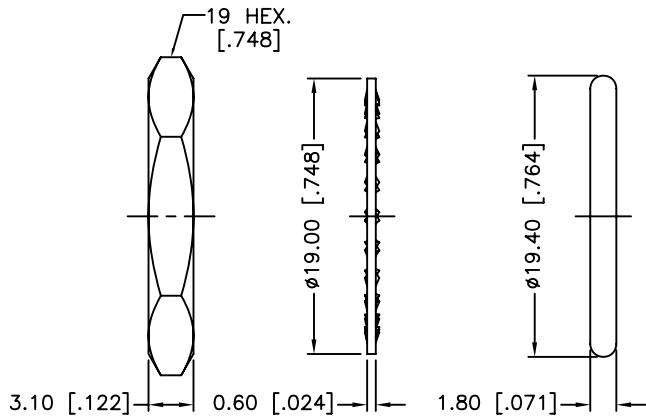
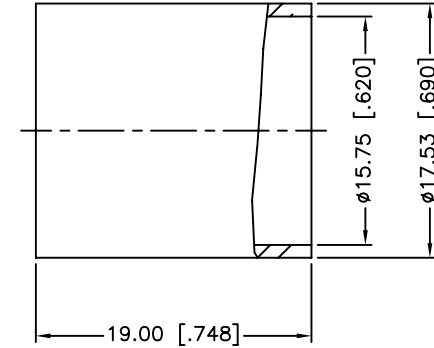
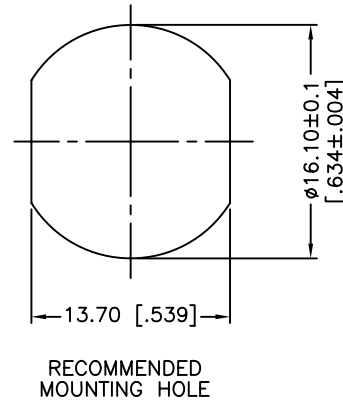
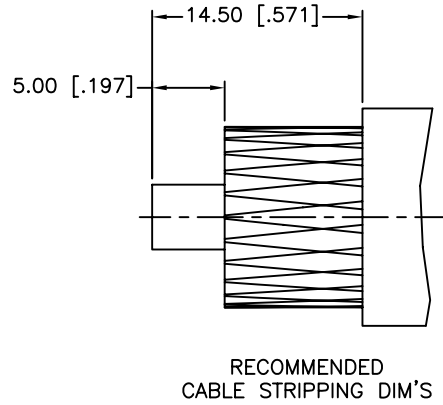

1. IMPEDANCE: 50 OHM
2. FREQUENCY RANGE: DC - 11 GHz
3. DIELECTRIC WITHSTANDING VOLTAGE: 2500 VRMS MIN.
4. DURABILITY: 500 CYCLES MIN.
5. CRIMPED FERRULE
HEX CRIMP SIZE .610"
6. CONTACT PIN TO SOLDER
7. MAX. PANEL THICKNESS=6.5mm

DESCRIPTION	MATERIAL	FINISH	QTY
7 FERRULE	BRASS	NEXCOTE	1
6 CONTACT PIN	PHOSPHOR BRONZE	GOLD	1
5 HEX NUT	BRASS	NEXCOTE	1
4 LOCK WASHER	BRASS	NEXCOTE	1
3 GASKET	SILICON RUBBER	RED	1
2 INSULATOR	PTFE	NATURAL	1
1 BODY	BRASS	NEXCOTE	1

UNLESS OTHERWISE SPECIFIED DIMENSIONS ARE IN MILLIMETERS. DIMENSIONS IN [] ARE IN INCHES AND FOR CUSTOMER REFERENCE ONLY.

UNLESS OTHERWISE SPECIFIED TOLERANCES FOR MILLIMETERS ARE:
 0.5 - 8mm ± 0.20mm
 8 - 30mm ± 0.40mm
 30 - 120mm ± 0.50mm

UNLESS OTHERWISE SPECIFIED TOLERANCES FOR INCHES ARE:
 .020 - .315 = ± 0.007"
 .315 - 1.180 = ± 0.015"
 1.180 - 4.724 = ± 0.020"

DO NOT SCALE DRAWING

APPROVALS	DATE
DRAWN M.ZHANG	08/31/11
CHECKED	
ISSUED	
SHEET 1 OF 1	
CAD FILE	C:/CONNEX/172264.DWG

PART DESCRIPTION			
Amphenol Connex			
N BULKHEAD CRIMP JACK (FOR LMR 600 CABLE)			
PART NO.		172264	
DWG. NO.	REV.	SIZE	SCALE
172264.DWG	B	A	NA