



The engineer's choice

**ebmpapst**

8414 NGH

INDEX

**1 General..... 3**

**2 Mechanics..... 3**

2.1 General..... 3

2.2 Connections ..... 3

**3 Operating Data ..... 4**

3.1 Operating Data - Electrical Interface - Input ..... 4

3.2 Electrical Operating Data ..... 5

3.3 Operating Data - Electrical Interface -Output..... 5

3.4 Electrical Features ..... 6

3.5 Aerodynamic ..... 7

3.6 Sound Data ..... 7

**4 Environment ..... 8**

4.1 General..... 8

4.2 Climatic requirements\*)..... 8

**5 Safety ..... 9**

5.1 Electrical Safety..... 9

5.2 Approval Tests ..... 9

**6 Reliability ..... 9**

6.1 General..... 9

**1 General**

Fan type	Fan	
Rotational direction looking at rotor	counterclockwise	
Airflow direction	Air outlet over struts	
Bearing system	Sleeve bearing	
Mounting position	any	

**2 Mechanics**

**2.1 General**

Width	80,0 mm	
Height	80,0 mm	
Depth	25,4 mm	
Weight	0,095 kg	
Housing material	Plastic	
Impeller material	Plastic	
Max. torque when mounted across both mounting flanges	wire outlet corner: 50 Ncm remaining corners: 70 Ncm	
Screw size	ISO 4762 - M4 degreased, without an additional brace and without washer	

**2.2 Connections**

Electrical connection	Wires	
Length of lead wire	L = 310 mm	
Tolerance	+/- 10,0 mm	
Wire gauge (AWG)	24	
Insulation diameter	1,55 mm	
Contact	see drawing	

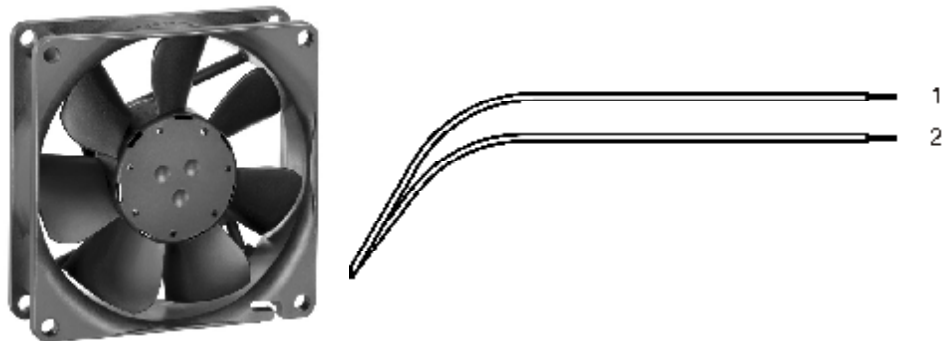

	Colour	Operation
Wire 1	red	+ UB
Wire 2	blue	- GND

**3 Operating Data**

**3.1 Operating Data - Electrical Interface - Input**

Control input	None
---------------	------

### 3.2 Electrical Operating Data

Measurement conditions: Normal air density = 1,2 kg/m<sup>3</sup>; Temperature 23°C +/- 3°C; Motor axis horizontal; warm-up time before measuring 5 minutes (unless otherwise specified). In the intake and outlet area should not be any solid obstruction within 0,5 m.

$\Delta p = 0$ : corresp. to free air flow (see section 3.5)  
 I: corresp. to arithm. mean current value

Features	Condition	Symbol	Values		
Voltage range	$\Delta p = 0$	U	18,0 V		26,0 V
Nominal voltage	$\Delta p = 0$	$U_N$		24,0 V	
Power consumption	$\Delta p = 0$	P	1,4 W	2,6 W	3,1 W
Tolerance	0001		+/- 17,5 %	+/- 12,5 %	+/- 15,0 %
Current consumption	$\Delta p = 0$	I	80 mA	110 mA	120 mA
Tolerance	0001		+/- 17,5 %	+/- 12,5 %	+/- 15,0 %
Speed	$\Delta p = 0$	n	2.700 1/min	3.600 1/min	3.900 1/min
Tolerance	0001		+/- 12,5 %	+/- 7,5 %	+/- 10,0 %
Starting current consumption				364 mA	

### 3.3 Operating Data - Electrical Interface -Output

Tacho type	None
------------	------

Alarm type	None
------------	------

### 3.4 Electrical Features

Electronic function	None	
Reversed polarity protection	Rectifying diode	
Max. residual current at $U_n$	$I_F \leq 5 \mu A$	
Locked rotor protection	Auto restart	
Locked rotor current at $U_n$	approx. 364 mA	
Clock signal $t_3/t_4$ at locked rotor	Typical: 0,2 s / 1,1 s $t_3$ : 0,06 s... 0,77 s $t_4$ : 0,3 s... 3,6 s	

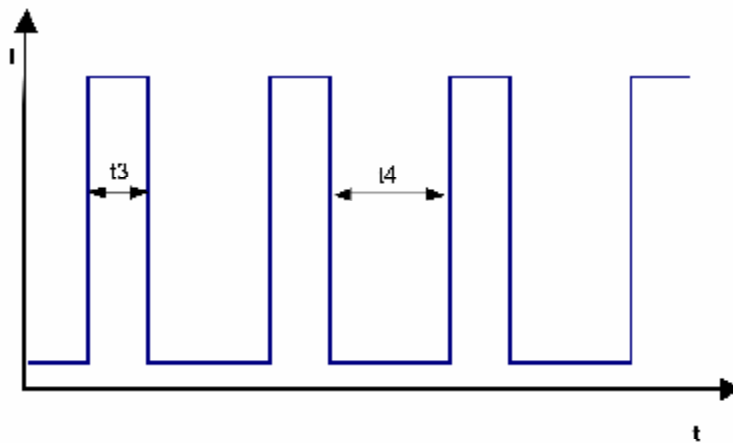

### 3.5 Aerodynamic

Measurement conditions: Measured with a double chamber intake rig acc. to DIN EN ISO 5801.  
 Normal air density = 1,2 kg/m<sup>3</sup>; Temperature 23°C +/- 3°C;  
 In the intake and outlet area should not be any solid obstruction within 0,5 m.

a.) Operation condition:

at free air flow
------------------

### 3.6 Sound Data

Measurement conditions: Sound pressure level: 1 Meter distance between microphone and the air intake.  
 Sound power level: Acc. to DIN 45635 part 38 (ISO 10302)  
 Measured in a semianchoic chamber with a background noise level of Lp(A) < 5 dB(A)  
 For further measurement conditions see section 3.5

a.) Operation condition:

3.600 1/min at free air flow
------------------------------

Optimal operating point	64,0 m <sup>3</sup> /h @ 14 Pa	
Sound power level at the optimal operating point	5,0 bel(A)	
Sound pressure level at free air flow, measured in rubber bands	37,0 dB(A)	

## 4 Environment

### 4.1 General

Min. permitted ambient temperature TU min.	-20 °C	
Max. permitted ambient temperature TU max.	70 °C	
Min. permitted storage temperature TL min.	-40 °C	
Max. permitted storage temperature TL max.	80 °C	

### 4.2 Climatic requirements \*)

Humidity requirements	humid heat, constant; according to DIN EN 60068-2-78, 14 days	
Water exposure	None	
Radiation exposure	None	
Dust requirements	None	
Salt fog requirements	None	
Harmful gas requirements	None	

\*) Permitted application area:

The product is intended for use in sheltered rooms with controlled temperature and controlled humidity. Directly exposure to water must be avoided.

Pollution degree 1 (according DIN EN 60664-1)

There is either no pollution or it occurs only dry, non-conductive pollution. The pollution has no negative impact. Please require severity levels and specification parameters from the responsible development departments



## 5 Safety

### 5.1 Electrical Safety

Dielectric strength DIN EN 60950 (VDE 0805) and DIN EN 60335 (VDE 0700) A.) Type test Measuring conditions: After 48h of storage at 95% R.H. and 25°C. No arcing or breakdown is allowed! All connections together to ground.	Not applicable	
B.) Routine test Measuring conditions: At indoor climate. No arcing or breakdown is allowed! All connections together to ground.	Not applicable	
Isolation resistance Measuring conditions: After 48h of storage at 95% R.H. and 25°C measured with U=500 VDC for 1 min.	RI > 10 MOhm	
clearance / creepage distance	1,0 mm / 1,2 mm	
Protection class	III	

### 5.2 Approval Tests

CE	Yes
UL	Yes / UL507, Electric Fans
VDE	Yes / Approval acc. to EN 60950 (VDE 0805) - Information technology equipment
CSA	Yes / C22.2 No. 113 Fans and Ventilators
CCC	No

The approval tests are observed to:

U approval max.:26,0 V @ TU approval max.: 70,0 °C

## 6 Reliability

### 6.1 General

Life expectancy L10 at TU = 40 °C	70.000 h	
Life expectancy L10 at TU max.	35.000 h	
Life expectancy L10 Delta (40 °C)	140.000 h	

Copies of the drawings and drawings of the parts and the parts themselves of the parts, based on the drawings, are not to be used for the production of parts. All dimensions are subject to the approval of ebm-papst. All dimensions are subject to the approval of ebm-papst. All dimensions are subject to the approval of ebm-papst.

Zeichnung nach DIN ISO 9001 beachten / refer to parts: non-metric L N ISO 9001

