

new product
information

LX1993 HIGH EFFICIENCY LED DRIVER

New Product Information and Sales Kit

Manufactured by:

Microsemi
Power Management Group
Garden Grove
Telephone: 714 898-8121

www.Microsemi.com

More than solutions – enabling possibilities

INTRODUCTION

CONFIDENTIAL INFORMATION

This new product introduction guide is intended for use only by Microsemi's sales people and authorized representatives and distributors. This material can be adapted for customer presentations, but the sales strategy and summary [pricing, availability, etc.] is confidential and should not be shown to customers.

DESCRIPTION

The LX1993 is a compact *high efficiency step-up boost controller* for driving white or color LEDs in backlight or front light systems and offers designers maximum flexibility with respect to efficiency and cost. The LX1993 implements a *pseudo-hysteretic pulse frequency modulation topology* and features an *internal N-Channel MOSFET*. Further, the LX1993 features control circuitry that is optimized for portable systems (e.g., quiescent supply current of 80 μ A (typ) and a shutdown current of less than 1 μ A). These design enhancements provide for improved performance in *battery operated systems applications*. The *device input voltage range is from 1.6V to 6.0*, allowing for a wide selection of system battery voltages and *start-up operation is guaranteed at 1.6V input*.

Programming the output current is readily achieved by using *one external current sense resistor* in series with the LEDs. In this configuration, LED current provides a feedback signal to the FB pin, maintaining constant current regardless of varying LED forward voltage (VF). Moreover, the LX1993 is capable of achieving *output currents in excess of 20mA*.

The LX1993 has an additional feature for *simple dynamic adjustment of the output current* (i.e., up to 100% of the maximum programmed current). Designers can make this adjustment via an analog reference signal or a direct PWM generated signal applied to the ADJ pin and any PWM amplitude is easily accommodated with a single external resistor.

The LX1993 is available in both *the 8-Pin MSOP*, thus requiring minimal PCB area..

SUMMARY

The LX1993 is a compact high efficiency step-up boost controller for driving white or color LEDs for improved performance in battery operated systems applications.



KEY PRODUCT INFORMATION

BLOCK DIAGRAM

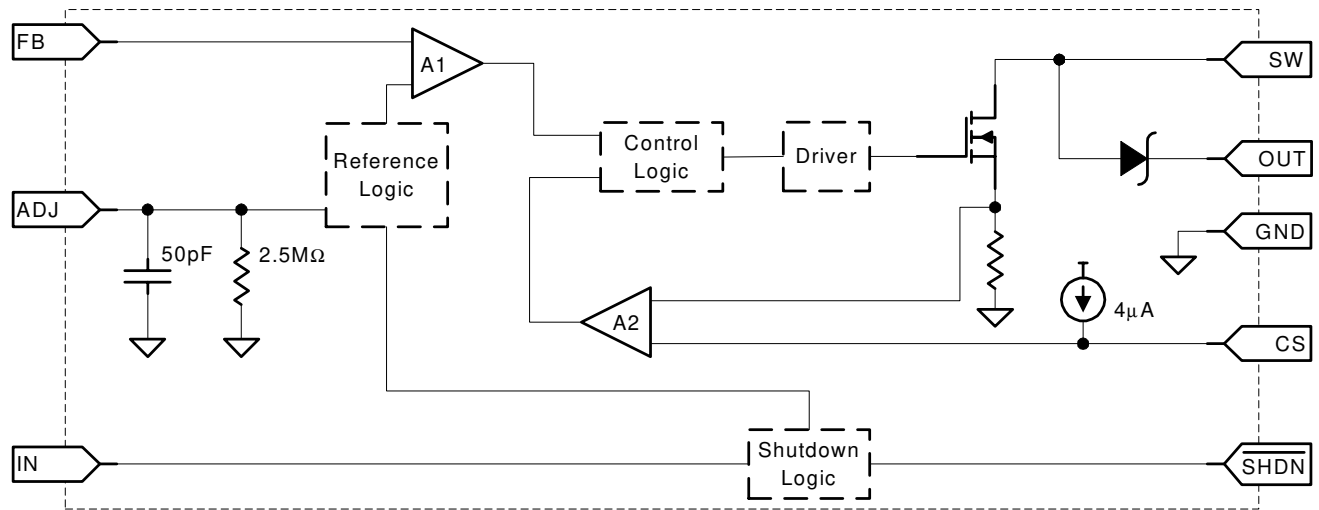

KEY FEATURES

- >80% Maximum Efficiency
- 70μA Typical Quiescent Supply Current
- Externally Programmable Peak Inductor Current Limit For Maximum Efficiency
- Logic Controlled Shutdown
- < 1μA Shutdown Current
- Dynamic Output Current Adjustment Via Analog Reference Or Direct PWM Input
- Internal Power MOSFET
- 8-Pin MSOP Package

TYPICAL APPLICATION

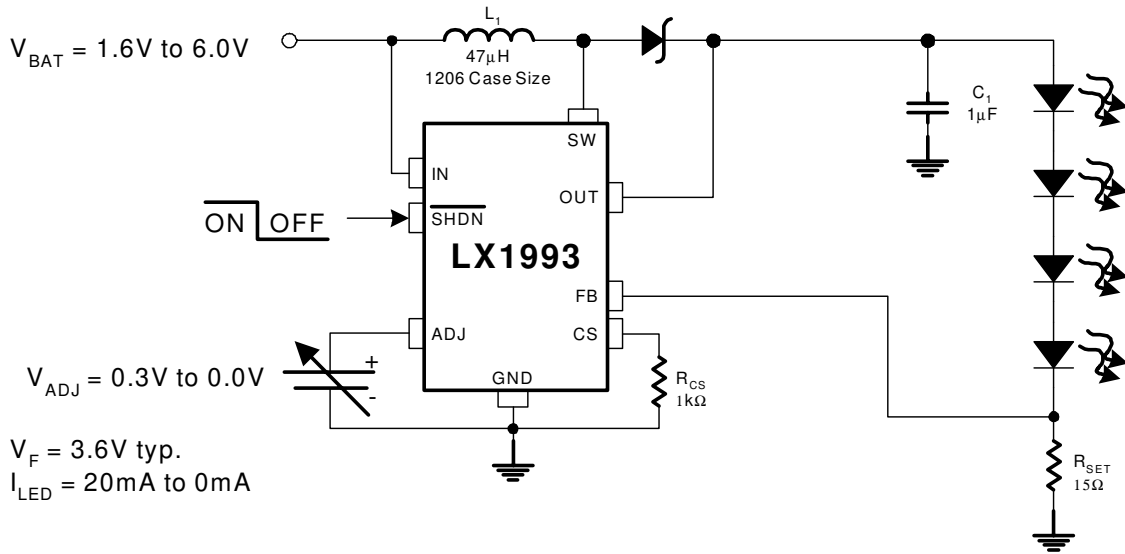
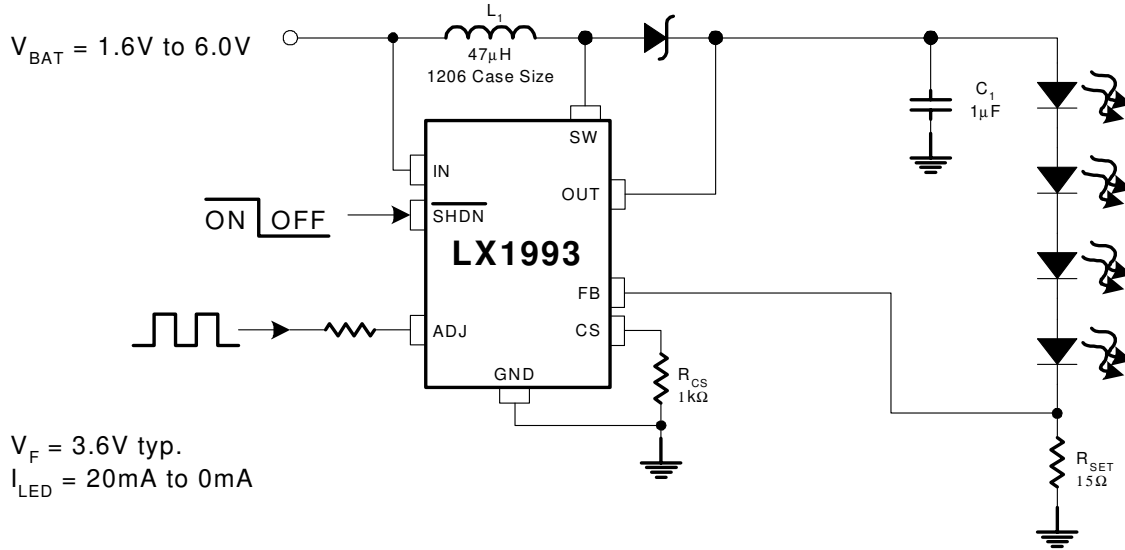

APPLICATIONS

- Pagers
- Wireless Phones
- PDAs
- Handheld Computers
- LED Driver
- Digital Camera Displays



COMPETITIVE ANALYSIS

LX1993

Competitor	Device	Package	Topology	V _{IN} Range	η Range	Temp. Range	Notes
Microsemi	LX1993	8 MSOP	PFM	1.6 ~ 6	Up to 85%	0 to 70°C	
Linear Tech	LTC1932	SOT23-6	PFM	1.0 ~ 10	Up to 80%	-40 to 85°C	Not Pin To Pin Compatible
MICREL	MIC2145	8 MSOP	PFM	2.4 ~ 16	Up to 85%	-40 to 85°C	Not Pin To Pin Compatible

Alternative Microsemi Solutions

Device	Description	Notes
LX1990	Dual LED Driver	<ul style="list-style-type: none"> • Direct Drive Not Designed For Boost Operation • Low Cost • Available 1/2002
LX1992	High Efficiency LED Driver	<ul style="list-style-type: none"> • PFM Boost Topology w/ External MOSFT • Low Cost; Greater than 90% Efficiency (η) • Currently Available



SALES STRATEGY

FIND SOCKETS

- Portable products
- Chains of colored or white LED displays
- Dimmable LED's with good color match
- Step-up conversion for multiple LED drive
- Two Cell Alkaline, NiCd or NiMH Battery Source

POSITIONING

- Low profile package
- Guaranteed startup voltage of 1.6V
- High efficiency PFM topology
- Single low value resistor sets output current
- DC Voltage or Low frequency PWM Dimming Capable

IMPORTANT FACTS TO REMEMBER

The LX1993 is a proprietary pin-out

SUMMARY

Pricing

Device	Package	(0 to 70°C)	
		DC	1000+
LX1993CDU	8 Pin MSOP	\$0.98	\$1.13

Availability

Samples: Now
Production: LX1993CDU NOW

Options

Packages: DU MSOP 8 Tape and Reel [MOQ 2500pcs]
Temperature: C Commercial 0 to 70°C

Technical Support

Datasheet: See Microsemi's Website
Application Note: See Datasheet
Evaluation Board: LXE1993

Factory Contacts

Technical Questions: Michael Calvert (714) 372-8484
 mailto: mcalvert@microsemi.com
Marketing Manager: Mike Tanaka (714) 372-8302
 mailto: mtanaka@microsemi.com