

microBUCK® Highly Integrated Synchronous Buck Regulators



FEATURES

- Compact scalable highly integrated solutions
- Output and over voltage protection
- > 93 % peak efficiency
- Easy to use and highly flexible CAD tool aids in design simulations to select right part
- Programmable soft-start and soft-shutdown
- Integrated Power MOSFETs

APPLICATIONS

- Desktop and server computers
- Notebook computers
- Digital HDTV and digital consumer applications
- Networking and telecommunication equipment
- LCD TV, STB, and other consumer applications
- Embedded applications
- Point of load power supplies

RESOURCES

- microBUCK product family datasheets: <http://www.vishay.com/power-ics/integrated-microbuck/>
- PowerCAD Simulation Design Tool: <http://www.vishay.com/power-ics/powercad-list/>
- For technical questions, contact PowerICtechsupport@vishay.com





POWER ICS
microBUCK® PRODUCT FAMILY



Power ICS - Compact Scalable Highly Integrated Solutions

microBUCK® PRODUCT FAMILY

		SiC401 A/B	SiC402 A/B	SiC403 A/B	SiC413	SiC414/424
	Package	MLPQ55-32L			SO-8	MLPQ44-28
	Package Size	5 x 5 x 0.9 (mm)			6.2 x 5 x 0.9 (mm)	4 x 4 x 0.9 (mm)
Operating Conditions	V _{IN}	3 V to 17 V	3 V to 28 V	3 V to 28 V	4.75 V to 26 V	3 V to 28 V
	V _{OUT}	0.6 V to 5.5 V			0.6 V to 13.2 V	0.75 V to 5.25 V
	Operating Frequency	200 kHz to 1 MHz			500 kHz	200 kHz to 1 MHz
	I _{OUT}	15 A	10 A	6 A	4 A	6 A
	Power save mode	•	•	•		•
	Peak efficiency	95 %	95 %	95 %	93 %	95 %
	Power good	•	•	•		•
Protection Features	Under voltage lockout	•	•	•	•	•
	Output over-voltage protection	•	•	•	•	•
	Output over-current protection	•	•	•	•	•
	Short circuit protection	•	•	•		
	Over temperature protection	•	•	•	•	•
Features	Soft-start and soft-shutdown	Programmable			Internal	Internal
	Integrated configurable LDO with bypass logic	•	•	•		•
	Output ceramic capacitor (no ESR requirement)	•	•	•	•	•
	Pseudo-fixed frequency adaptive on-time control	•	•	•		•
	1 % internal reference voltage	•	•	•		•
	Integrated bootstrap diode	•	•	•	•	•



POWER ICS
microBUCK® PRODUCT FAMILY



Power ICS - Compact Scalable Highly Integrated Solutions

microBUCK® PRODUCT FAMILY (continued...)

	SiP12107	SiP12108	SiP12109	SiP12110	
Package	MLP33-16L				
Package Size	3 x 3 x 0.9 (mm)				
Operating Conditions	V_{IN}	2.8 V to 5.5 V		4.5 V to 16 V	
	V_{OUT}	0.6 V to 4.6 V		0.6 V to 5.5 V	
	Operating Frequency	200 kHz to 4 MHz	200 kHz to 4 MHz	400 kHz to 1.5 MHz	400 kHz to 1.5 MHz
	I_{OUT}	3 A	6 A	4 A	6 A
	Power save mode	•	•	•	•
	Peak efficiency	95 %	95 %	95 %	95 %
	Protection Features	Power good	•	•	•
Under voltage lockout		•	•	•	•
Output over-voltage protection		•	•	•	•
Output over-current protection		•	•	•	•
Short circuit protection		•	•	•	•
Over temperature protection		•	•	•	•
Features	Soft-start and soft-shutdown	Internal			
	Output ceramic capacitor (no ESR requirement)	•	•	•	•
	Pseudo-fixed frequency adaptive on-time control	•	•	•	•
	1 % internal reference voltage	•	•	•	•
	Integrated bootstrap diode			•	•

SIC401A/B, SIC402A/B, and SIC403A/B

FUNCTIONAL BLOCK DIAGRAM

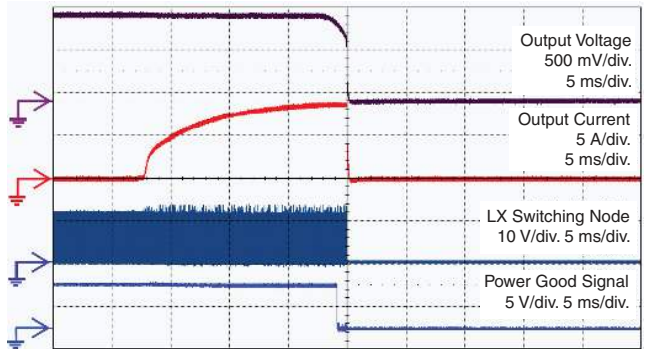
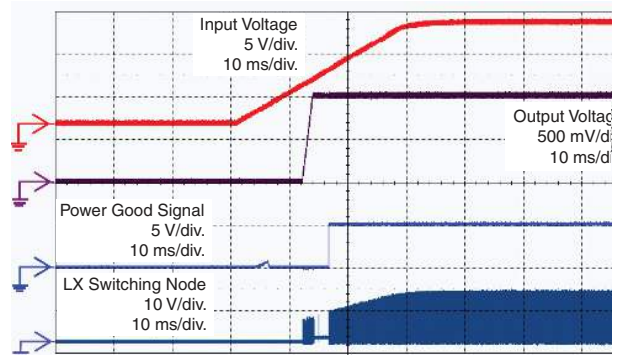
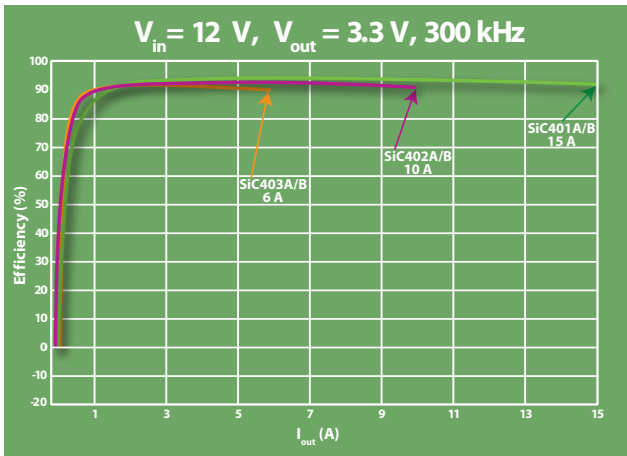
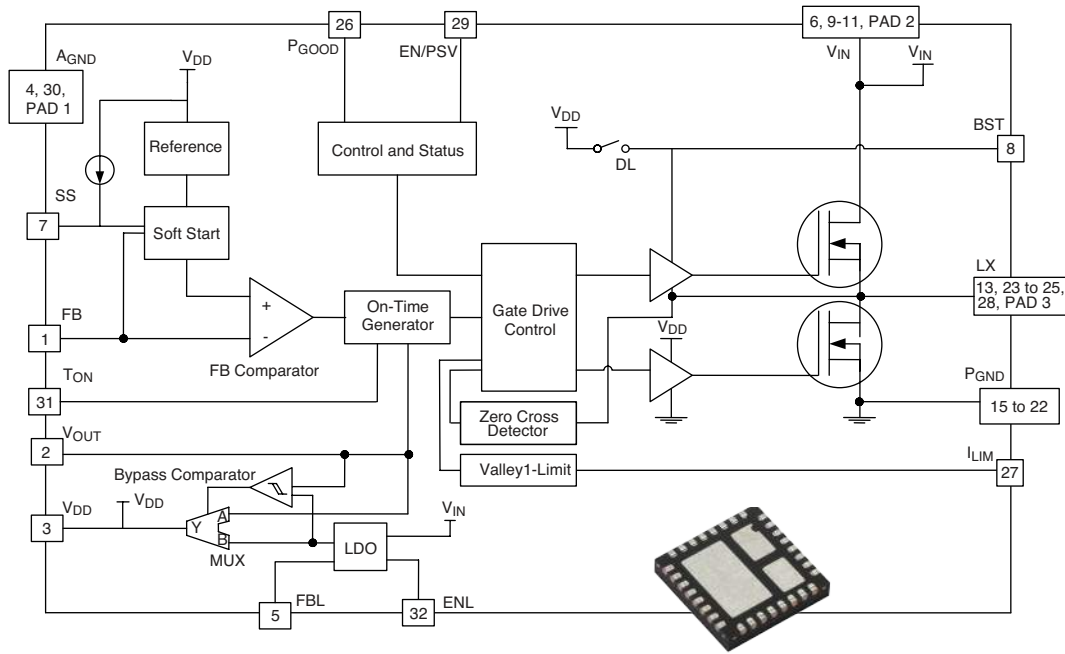

SIC401A/B, SIC402A/B, and SIC403A/B (continued...)

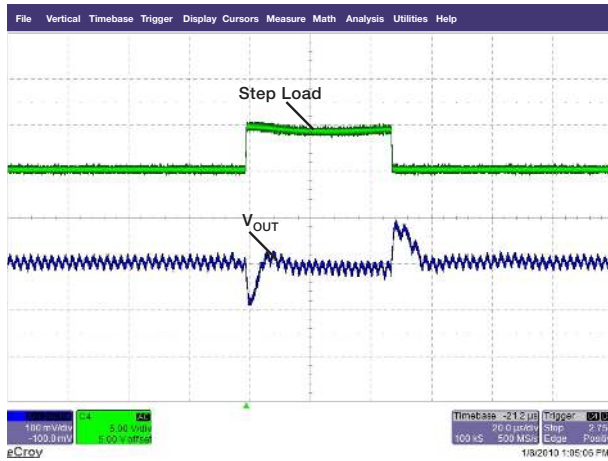

Transient response I_{OUT} 5 A

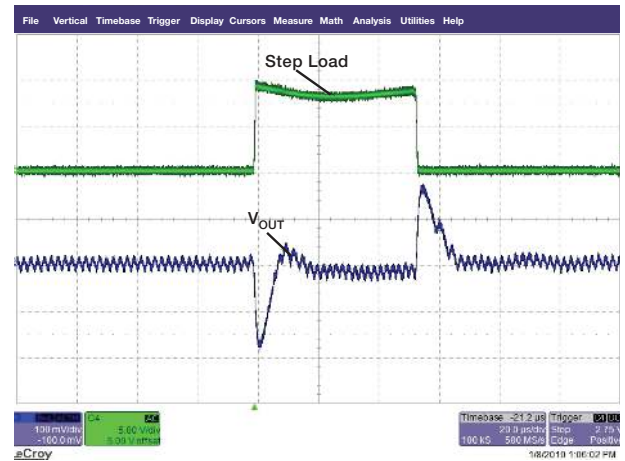

Transient response I_{OUT} 10 A



SiC414

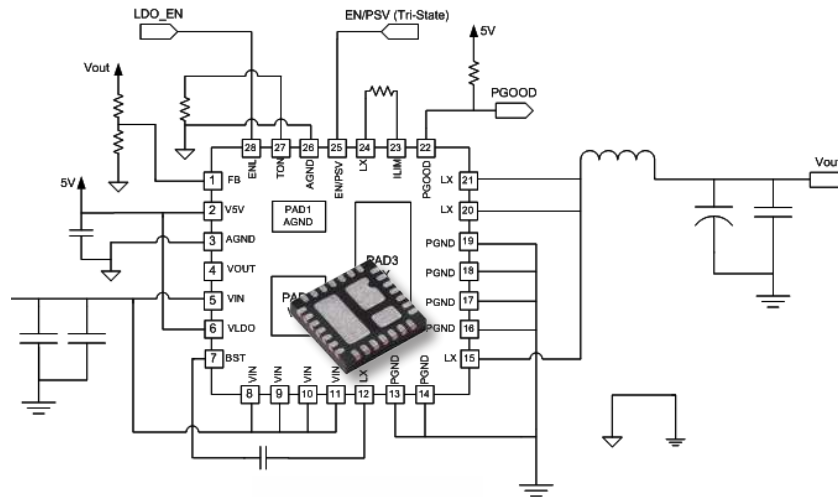

SiC414CD typical application circuit

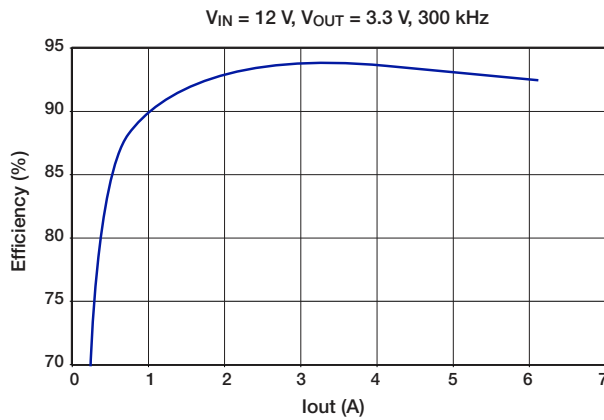

SiC414CD efficiency curve

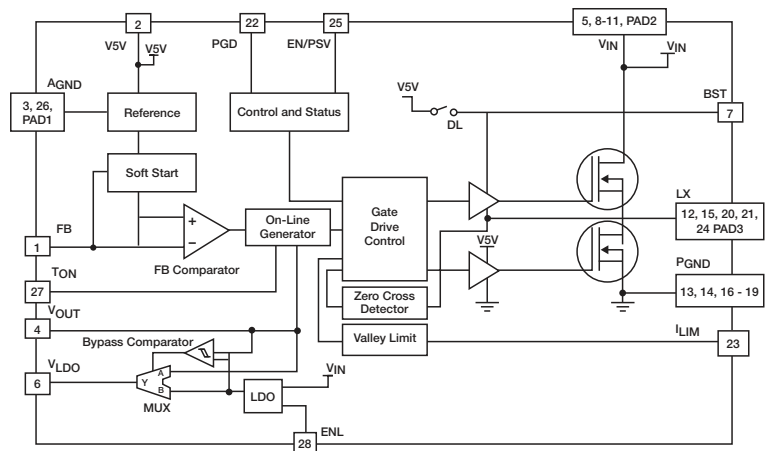

SiC414CD block diagram

SiC413

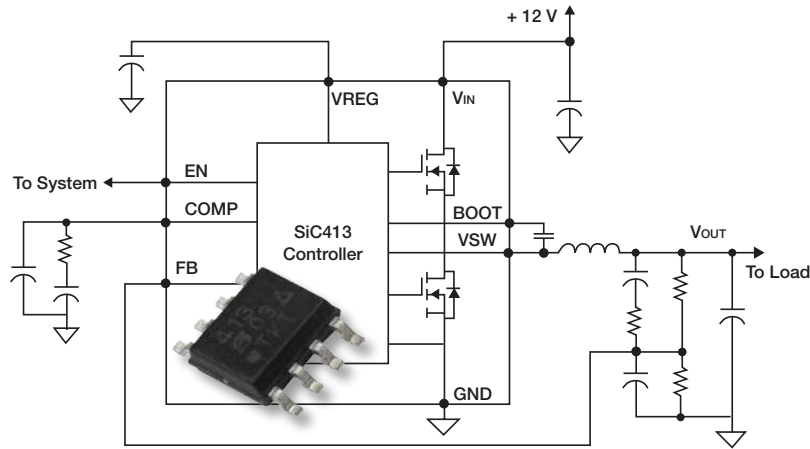

SiC413CB typical application circuit

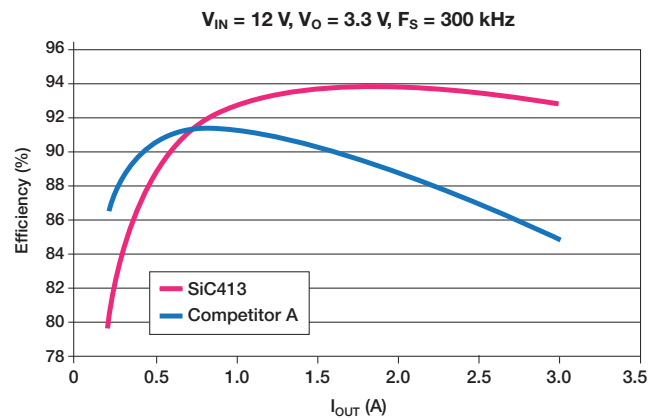

SiC413CB versus competitor efficiency

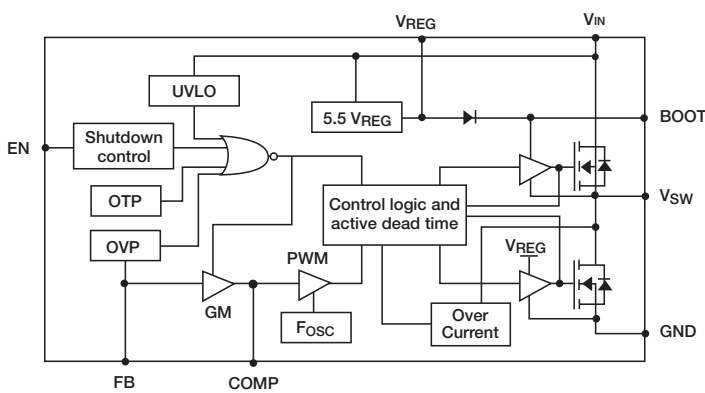

SiC413CB block diagram

SIC413

SiC413CB Versus Competitor Thermals	
SiC413 is 23.2 °C cooler	
V_{IN}	12 V
V_{OUT}	3.3 V
I_{OUT}	3.0 A
SiC413 efficiency	93 %
Competitor's efficiency	85 %

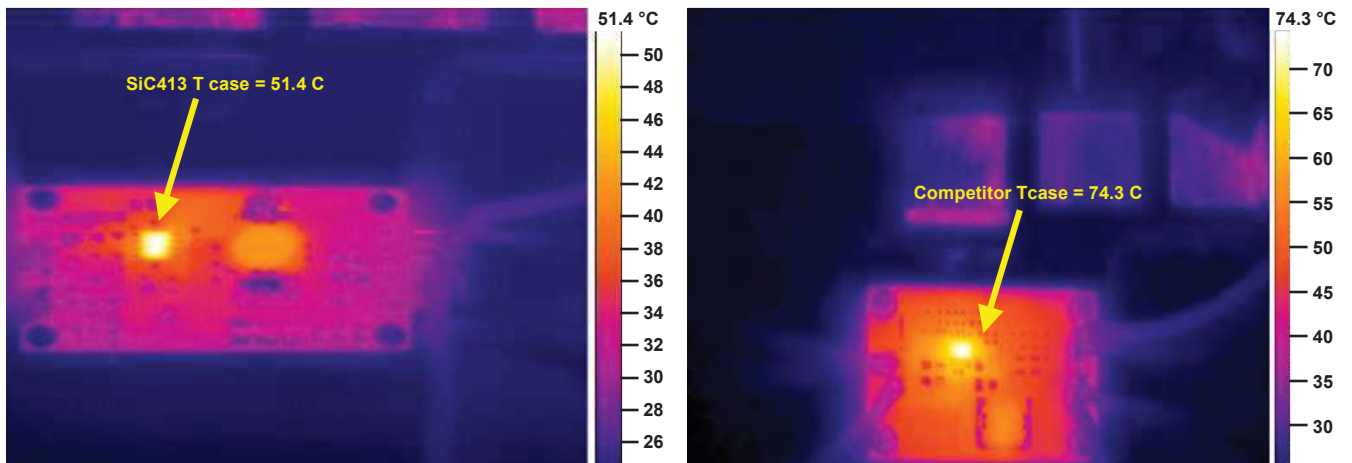

SiC413CB versus competitor thermals

SIP12109

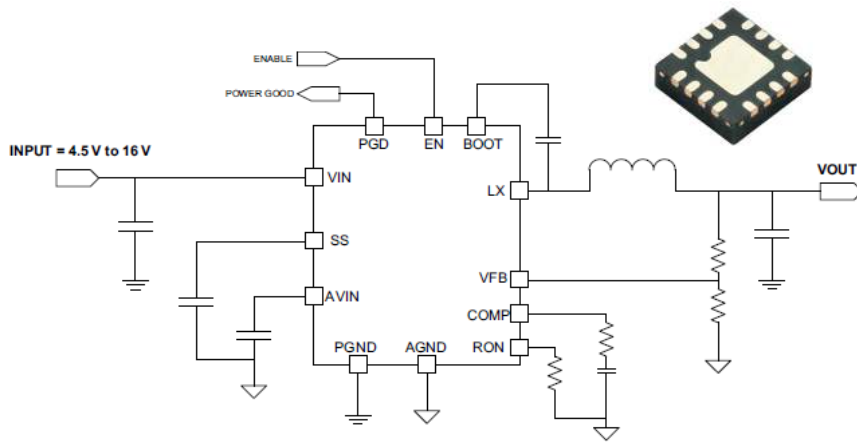

SiP12109 Typical Application Circuit

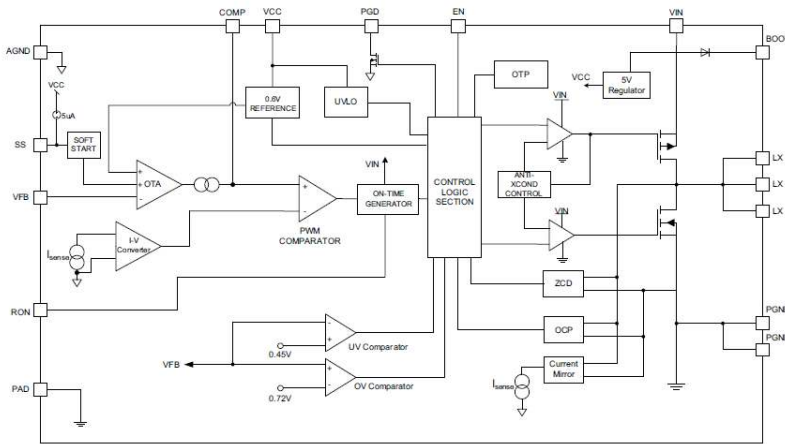

SiP12109 Block Diagram

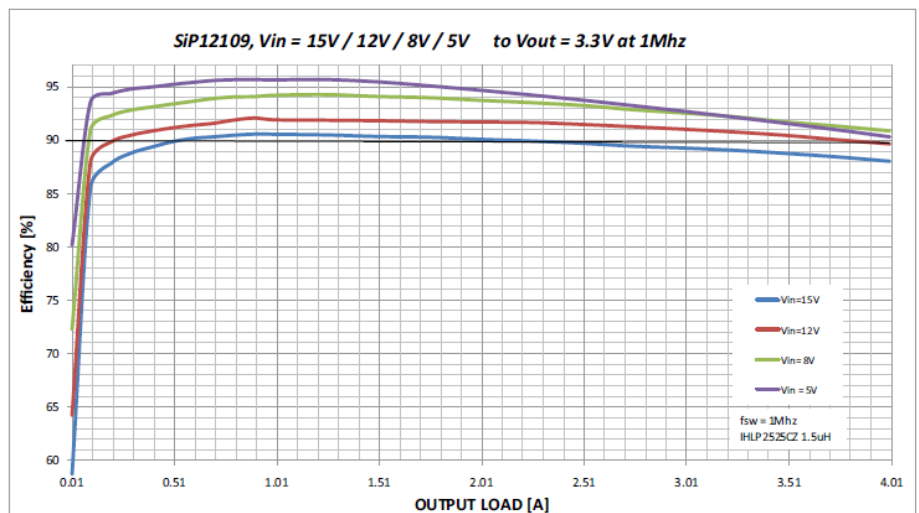

SiP12109 Efficiency Curve

**WORLDWIDE SALES CONTACTS****THE AMERICAS****UNITED STATES**

VISHAY AMERICAS
ONE GREENWICH PLACE
SHELTON, CT 06484
UNITED STATES
PH: +1-402-563-6866
FAX: +1-402-563-6296

ASIA**SINGAPORE**

VISHAY INTERTECHNOLOGY ASIA PTE LTD.
37A TAMPINES STREET 92 #07-00
SINGAPORE 528886
PH: +65-6788-6668
FAX: +65-6788-0988

P.R. CHINA

VISHAY CHINA CO., LTD.
15D, SUN TONG INFOPORT PLAZA
55 HUAI HAI WEST ROAD
SHANGHAI 200030
P.R. CHINA
PH: +86-21-5258 5000
FAX: +86-21-5258 7979

JAPAN

VISHAY JAPAN CO., LTD.
SHIBUYA PRESTIGE BLDG. 4F
3-12-22, SHIBUYA
SHIBUYA-KU
TOKYO 150-0002
JAPAN
PH: +81-3-5466-7150
FAX: +81-3-5466-7160

EUROPE**GERMANY**

VISHAY ELECTRONIC GMBH
DR.-FELIX-ZANDMAN-PLATZ 1
95100 SELB
GERMANY
PH: +49-9287-71-0
FAX: +49-9287-70435

FRANCE

VISHAY S.A.
199, BD DE LA MADELEINE
06003 NICE, CEDEX 1
FRANCE
PH: +33-4-9337-2727
FAX: +33-4-9337-2726

UNITED KINGDOM

VISHAY LTD.
SUITE 6C, TOWER HOUSE
ST. CATHERINE'S COURT
SUNDERLAND ENTERPRISE PARK
SUNDERLAND SR5 3XJ
UNITED KINGDOM
PH: +44-191-516-8584
FAX: +44-191-549-9556