

DESCRIPTION

The EV2122-J-00A is used for demonstrating the performance of MPS's MP2122, an internally compensated 1MHz fixed-frequency dual PWM synchronous step-down regulator.

MP2122 is ideal for powering portable equipment that runs from a single cell Lithium-Ion (Li+) Battery due to 45uA low quiescent current. The output voltage can be regulated as low as 0.608V.

With peak current mode control and internal compensation, the MP2122 requires a minimum number of readily available standard external components and is available in an 8-pin TSOT23 package.

ELECTRICAL SPECIFICATION

Parameter	Symbol	Value	Units
Input Voltage	V_{IN}	2.7-6	V
Output Voltage	V_{OUT1}	1.8	V
	V_{OUT2}	1.2	V
Output Current	I_{OUT1}	2	A
	I_{OUT2}	2	A

FEATURES

- Dual 2A Output Current
- Above 95% Peak Efficiency
- Above 80% Light Load Efficiency
- Wide 2.7V to 6V Operating Input Range
- 100mΩ and 40mΩ Internal Power MOSFET
- 1MHz Fixed Switching Frequency
- Adjustable Output from 0.608V to V_{IN}
- 180° out of phase operation
- 100% duty cycle operation
- 45uA Quiescent current
- Cycle-by-cycle Over Current Protection
- Short Circuit Protection with Hiccup Mode
- Thermal shutdown
- Available in 8-pin TSOT23 Package

APPLICATIONS

- Small/Handhold devices
- DVD Drivers
- Portable Instruments
- Smartphone and Feature Phones
- Battery-Powered devices

All MPS parts are lead-free and adhere to the RoHS directive. For MPS green status, please visit MPS website under Quality Assurance. "MPS" and "The Future of Analog IC Technology" are Registered Trademarks of Monolithic Power Systems, Inc.

TYPICAL APPLICATION



Board Number	MPS IC Number
EV2122-J-00A	MP2122GJ

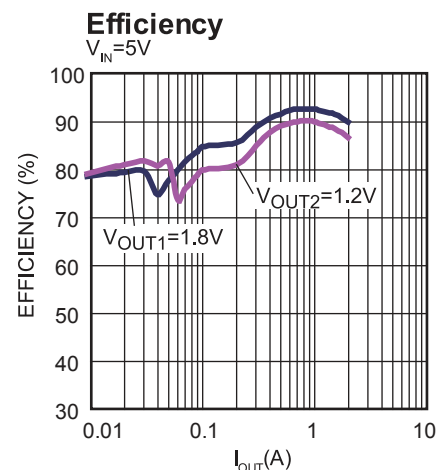

EVALUATION BOARD SCHEMATIC

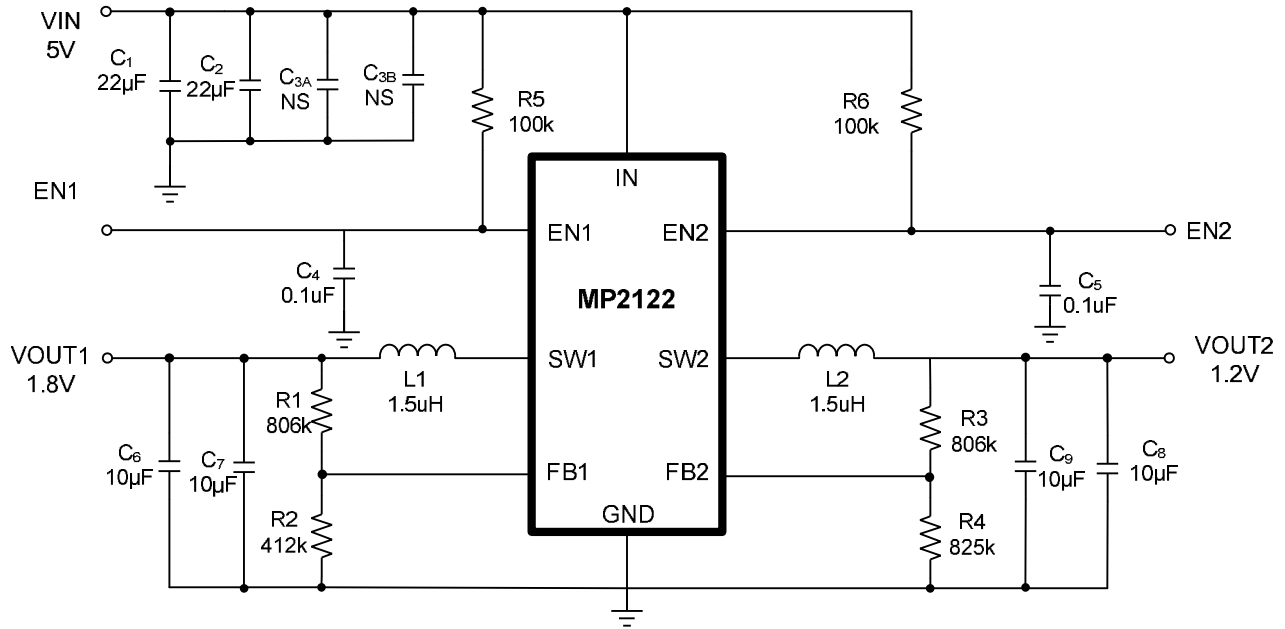

EV2122-J-00A BILL OF MATERIALS

Qty	Ref	Value	Description	Package	Manufacturer	Manufacturer P/N
1	C1	22uF	Ceramic Cap., 16V, 20%, X5R	0805	muRata	GRM21BR60J226ME39L
1	C2	22uF	Ceramic Cap., 16V, 20%, X5R	0805	muRata	GRM21BR60J226ME39L
0	C3A	NS				
0	C3B	NS				
2	C4, C5	0.1uF	Ceramic Cap, 16V,X7R	0603	muRata	GRM188R71C104KA01D
4	C6, C7, C8, C9	10uF	Ceramic Cap, 16V, 20%, X5R	0805	muRata	GRM21BR61A106KE19L
2	R1, R3	806k	Thick Film, 1/10W, 1%	0603	royal	RL0603FR-07806KL
1	R2	412k	Thick Film, 1/10W, 1%	0603	royal	RL0603FR-07412KL
1	R4	825k	Thick Film, 1/10W, 1%	0603	royal	RL0603FR-07825KL
2	R5, R6	100k	Thick Film, 1/10W, 1%	0603	royal	RL0603FR-07100KL
2	L1, L2	1.5uH	Inductor, 9.57mohm, 11.5A		Würth	744312150
1	U1		DC-DC module	TSOT23-8	MPS	MP2122GJ

PRINTED CIRCUIT BOARD LAYOUT

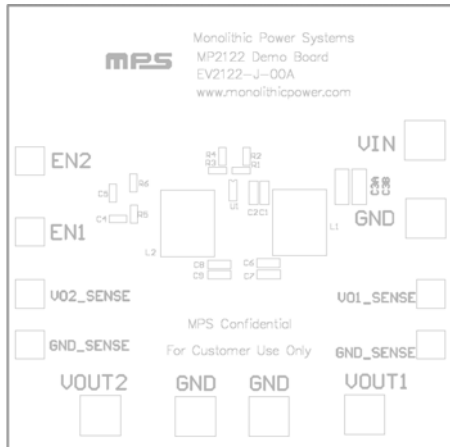

Figure 1—Top Silk Layer

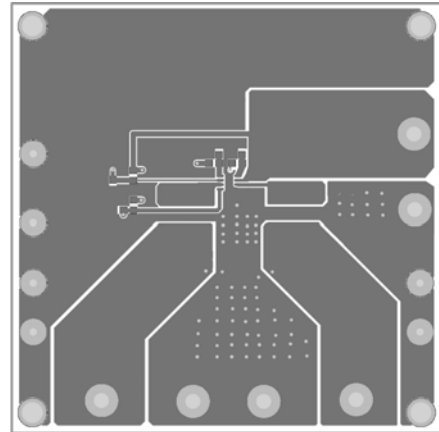

Figure 2—Top Layer

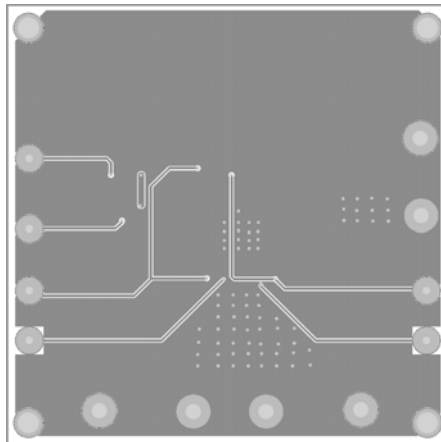

Figure 3—Bottom Layer

QUICK START GUIDE

The board layout accommodates most commonly used components.

1. Connect the positive and negative terminals of the load to VOUT1, VOUT2 and GND pins, respectively.
2. Preset Power Supply output between 2.7V and 6V, and turn off the power supply.
3. Connect Power Supply terminals to:
 - a. Positive (+): VIN
 - b. Negative (-): GND
4. Turn Power Supply on after making connections. The board will automatically start-up.
5. To use the Enable function, apply a digital input to the EN pin. Drive EN higher than 1.2V to turn on the regulator or less than 0.4V to turn it off.

LAYOUT RECOMMENDATION OF MP2122

Proper layout of the switching power supplies is very important, and sometimes critical to make it work properly. Especially, for the high switching converter, if the layout is not carefully done, the regulator could show poor line or load regulation, stability issues.

For MP2122, the input capacitor and feedback resistors should be placed as close as possible to the IC pins. As shown in Figure 4. The 0805 size ceramic capacitors (C1 and C2) are used for the input capacitor, please make sure the two ends of the ceramic capacitor be directly connected to PIN7 (the Power Input Pin) and PIN5 (the Power GND Pin). The R1, R2 and R3, R4 are the feedback resistors, please make sure they are as close as possible to the feedback pins (PIN8 and PIN1).

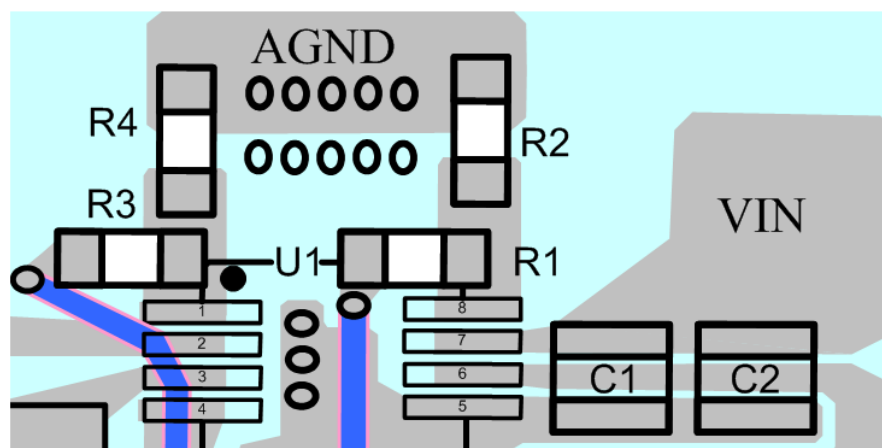

Figure 4

NOTICE: The information in this document is subject to change without notice. Users should warrant and guarantee that third party Intellectual Property rights are not infringed upon when integrating MPS products into any application. MPS will not assume any legal responsibility for any said applications.