

WIRELESS & SENSING

SX1504/SX1505/SX1506

4/8/16 Channel GPIO with NINT and NRESET

GENERAL DESCRIPTION

The SX1504, SX1505 and SX1506 are complete General Purpose parallel Input/Output (GPIO) expanders ideal for low power handheld battery powered equipment. They allow easy serial expansion of I/O through a standard I²C interface. GPIO devices can provide additional control and monitoring when the microcontroller or chipset has insufficient I/O ports, or in systems where serial communication and control from a remote location is advantageous.

These devices can also act as a level shifter to connect a microcontroller running at one voltage level to a component running at a different voltage level. The core is operating as low as 2.5V while the I/O banks can operate between 2.5V and 5.5V independent of the core voltage and each other.

Each GPIO is programmable via 8-bit configuration registers. Data registers, direction registers, pull-up/pull-down registers, interrupt mask registers and interrupt registers allow the system master to program and configure 4 or 8 or 16-GPIOs using a standard 400kHz I²C interface.

The SX1504, SX1505 and SX1506 offer a unique fully programmable logic functions like a PLD to give more flexibility and reduce external logic gates used for standard applications.

The SX1504, SX1505 and SX1506 have the ability to generate mask-programmable interrupts based on falling/rising edge of any of its GPIO lines. A dedicated pin indicates to a host controller that a state change occurred in one or more of the GPIO lines.

The SX1504, SX1505 and SX1506 each come in a small QFN-UT-20/28 package. All devices are rated from -40°C to +85°C temperature range.

ORDERING INFORMATION

Part Number	I/O Channels	Package
SX1504I087TRT	4	QFN-UT-20
SX1505I087TRT	8	QFN-UT-20
SX1506I091TRT	16	QFN-UT-28
SX1502EVK ⁽¹⁾	8	Evaluation Kit

⁽¹⁾ SX1502I087TRT based, unique evaluation kit for the three parts.

KEY PRODUCT FEATURES

- 4/8/16 channel of I/Os
 - True bi-directional style I/O
 - Programmable Pull-up/Pull-down
 - Push/Pull outputs
- 2.5V to 5.5V independent operating voltage for all supply rails (VDDM, VCC1, VCC2)
- 5.5V compatible I/Os, up to 24mA output sink (no total sink current limit)
- Fully programmable logic functions (PLD)
- 400kHz 2-wire I²C compatible slave interface
- Open drain active low interrupt output (NINT)
 - Bit maskable
 - Programmable edge sensitivity
- Power-On Reset and reset input (NRESET)
- Ultra low current consumption of typ. 1uA
- -40°C to +85°C operating temperature range
- Ultra-Thin 3x3mm QFN-UT-20 package (SX1504/SX1505)
- Ultra-Thin 4x4mm QFN-UT-28 package (SX1506)
- Pb & Halogen Free, RoHS/WEEE compliant

TYPICAL APPLICATIONS

- Cell phones, PDAs, MP3 players
- Digital camera
- Portable multimedia player
- Notebooks
- GPS Units
- Industrial, ATE
- Any battery powered equipment

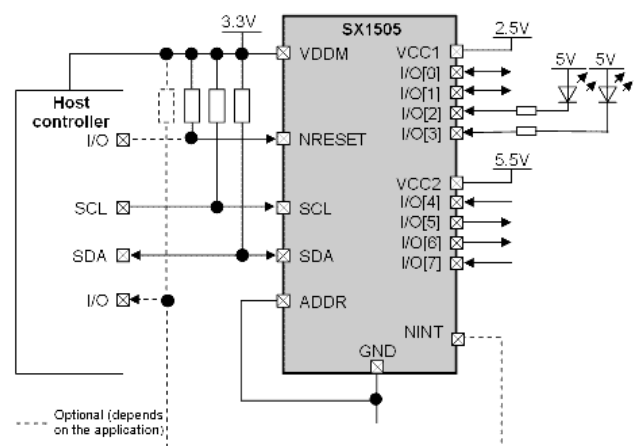

Table of Contents

GENERAL DESCRIPTION	1
ORDERING INFORMATION	1
KEY PRODUCT FEATURES	1
TYPICAL APPLICATIONS	1
1 PIN DESCRIPTION	4
1.1 SX1504 4-channel GPIO	4
1.2 SX1505 8-channel GPIO	5
1.3 SX1506 16-channel GPIO	6
2 ELECTRICAL CHARACTERISTICS	7
2.1 Absolute Maximum Ratings	7
2.2 Electrical Specifications	7
3 TYPICAL OPERATING CHARACTERISTICS	10
3.1 IDDM vs. VDDM	10
3.2 VOL vs. IOL	10
3.3 VOH vs. IOH	11
4 BLOCK DETAILED DESCRIPTION	12
4.1 SX1504 4-channel GPIO	12
4.2 SX1505 8-channel GPIO	12
4.3 SX1506 16-channel GPIO	13
4.4 Reset (NRESET)	13
4.5 2-Wire Interface (I ² C)	14
4.5.1 WRITE	14
4.5.2 READ	15
4.5.3 READ - STOP separated format (SX1504 and SX1505 only)	15
4.6 Interrupt (NINT)	16
4.7 Programmable Logic Functions (PLD)	16
4.7.1 SX1504	16
4.7.2 SX1505	17
4.7.3 SX1506	17
4.7.4 Tutorial	18
5 CONFIGURATION REGISTERS	19
5.1 SX1504 4-channel GPIO	19
5.2 SX1505 8-channel GPIO	20
5.3 SX1506 16-channel GPIO	22
6 APPLICATION INFORMATION	26
6.1 Typical Application Circuit	26
6.2 Typical LED Operation	26
6.2.1 LED ON/OFF Control	26
6.2.2 LED Intensity Control	27
6.3 Keypad Implementation	27
6.4 Level Shifter Implementation Hints	27
7 PACKAGING INFORMATION	28

WIRELESS & SENSING

7.1	QFN-UT 20-pin Outline Drawing	28
7.2	QFN-UT 20-pin Land Pattern	28
7.3	QFN-UT 28-pin Outline Drawing	29
7.4	QFN-UT 28-pin Land Pattern	29
8	SOLDERING PROFILE	30

WIRELESS & SENSING

1 PIN DESCRIPTION

1.1 SX1504 4-channel GPIO

Pin	Symbol	Type	Description
1	NRESET	DIO	Active low reset
2	SDA	DIO	I ² C serial data line
3	NC1	-	Leave open, not connected
4	SCL	DI	I ² C serial clock line
5	I/O[0]	DIO ^(*)	I/O[0], at power-on configured as an input
6	I/O[1]	DIO ^(*)	I/O[1], at power-on configured as an input
7	VCC1	P	I/O supply voltage
8	GND	P	Ground Pin
9	I/O[2]	DIO ^(*)	I/O[2], at power-on configured as an input High sink I/O.
10	I/O[3]	DIO ^(*)	I/O[3], at power-on configured as an input High sink I/O.
11	NINT	DO	Active low interrupt output
12	ADDR	DI	Address input, connect to VDDM or GND
13	NC2	-	Leave open, not connected
14	VDDM	P	Main supply voltage
15	NC3	-	Leave open, not connected
16	NC4	-	Leave open, not connected
17	NC7	-	Connect to VCC1
18	GND	P	Ground Pin
19	NC5	-	Leave open, not connected
20	NC6	-	Leave open, not connected

A: Analog
D: Digital
I: Input
O: Output
P: Power

(*) This pin is programmable through the I²C interface

Table 1 – SX1504 Pin Description

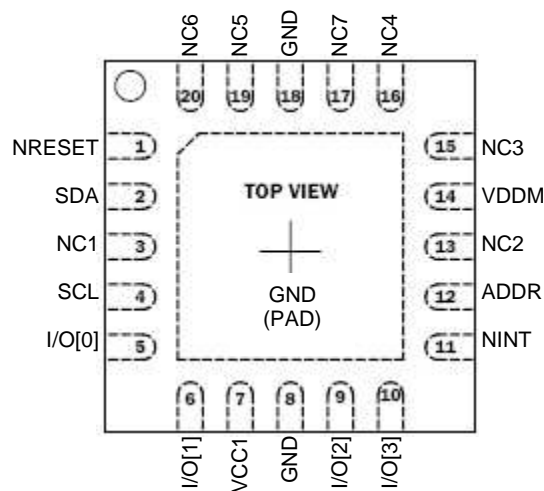

Figure 1 – SX1504 QFN-UT-20 Pinout

WIRELESS & SENSING

1.2 SX1505 8-channel GPIO

Pin	Symbol	Type	Description
1	NRESET	DIO	Active low reset
2	SDA	DIO	I ² C serial data line
3	NC1	-	Leave open, not connected
4	SCL	DI	I ² C serial clock line
5	I/O[0]	DIO ^(*)	I/O[0], at power-on configured as an input
6	I/O[1]	DIO ^(*)	I/O[1], at power-on configured as an input
7	VCC1	P	Supply voltage for Bank A I/O[0-3]
8	GND	P	Ground Pin
9	I/O[2]	DIO ^(*)	I/O[2], at power-on configured as an input High sink I/O.
10	I/O[3]	DIO ^(*)	I/O[3], at power-on configured as an input High sink I/O.
11	NINT	DO	Active low interrupt output
12	ADDR	DI	Address input, connect to VDDM or GND
13	NC2	-	Leave open, not connected
14	VDDM	P	Main supply voltage
15	I/O[4]	DIO ^(*)	I/O[4], at power-on configured as an input
16	I/O[5]	DIO ^(*)	I/O[5], at power-on configured as an input
17	VCC2	P	Supply voltage for Bank B I/O[4-7]
18	GND	P	Ground Pin
19	I/O[6]	DIO ^(*)	I/O[6], at power-on configured as an input
20	I/O[7]	DIO ^(*)	I/O[7], at power-on configured as an input

A: Analog
D: Digital
I: Input
O: Output
P: Power

(*1) This pin is programmable through the I²C interface

Table 2 – SX1505 Pin Description

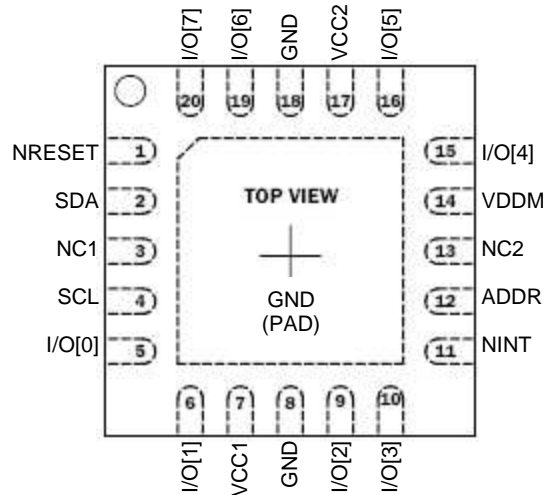

Figure 2 – SX1505 QFN-UT-20 Pinout

WIRELESS & SENSING

1.3 SX1506 16-channel GPIO

Pin	Symbol	Type	Description
1	GND	P	Ground Pin
2	I/O[2]	DIO ^(*)	I/O[2], at power-on configured as an input
3	I/O[3]	DIO ^(*)	I/O[3], at power-on configured as an input
4	VCC1	P	I/O supply voltage for Bank A I/O[0-7]
5	I/O[4]	DIO ^(*)	I/O[4], at power-on configured as an input
6	I/O[5]	DIO ^(*)	I/O[5], at power-on configured as an input
7	GND	P	Ground Pin
8	I/O[6]	DIO ^(*)	I/O[6], at power-on configured as an input High sink I/O.
9	I/O[7]	DIO ^(*)	I/O[7], at power-on configured as an input High sink I/O.
10	NINT	DO	Active low interrupt output
11	NC	-	Leave open, not connected
12	VDDM	P	Main supply voltage
13	I/O[8]	DIO ^(*)	I/O[8], at power-on configured as an input
14	I/O[9]	DIO ^(*)	I/O[9], at power-on configured as an input
15	GND	P	Ground Pin
16	I/O[10]	DIO ^(*)	I/O[10], at power-on configured as an input
17	I/O[11]	DIO ^(*)	I/O[11], at power-on configured as an input
18	VCC2	P	I/O supply voltage for Bank B I/O[8-15]
19	I/O[12]	DIO ^(*)	I/O[12], at power-on configured as an input
20	I/O[13]	DIO ^(*)	I/O[13], at power-on configured as an input
21	GND	P	Ground Pin
22	I/O[14]	DIO ^(*)	I/O[14], at power-on configured as an input High sink I/O.
23	I/O[15]	DIO ^(*)	I/O[15], at power-on configured as an input High sink I/O.
24	NRESET	DIO	Active low reset
25	SDA	DIO	I ² C serial data line
26	SCL	DI	I ² C serial clock line
27	I/O[0]	DIO ^(*)	I/O[0], at power-on configured as an input
28	I/O[1]	DIO ^(*)	I/O[1], at power-on configured as an input

A: Analog
D: Digital
I: Input
O: Output
P: Power

(*1) This pin is programmable through the I²C interface

Table 3 – SX1506 Pin Description

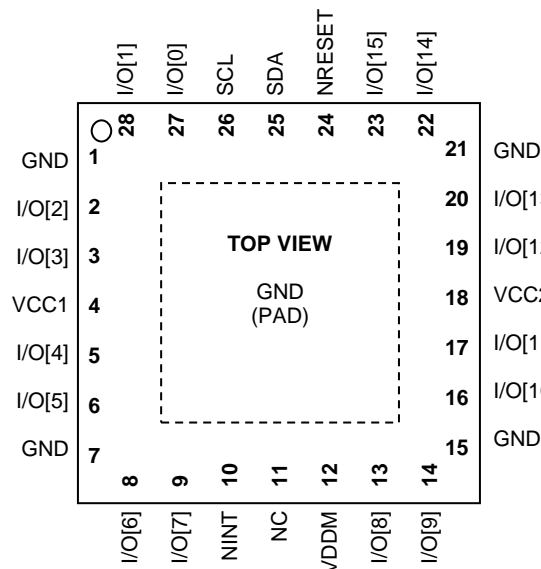

Figure 3 – SX1506 QFN-UT-28 Pinout

WIRELESS & SENSING
2 ELECTRICAL CHARACTERISTICS
2.1 Absolute Maximum Ratings

Stress above the limits listed in the following table may cause permanent failure. Exposure to absolute ratings for extended time periods may affect device reliability. The limiting values are in accordance with the Absolute Maximum Rating System (IEC 134). All voltages are referenced to ground (GND).

Symbol	Description	Min	Max	Unit
VDDM _{max}	Main supply voltage	- 0.4	6.0	V
VCC1,2 _{max}	I/O banks supply voltage	- 0.4	6.0	V
V _{ESD HBM}	Electrostatic handling HBM model ⁽¹⁾	-	1500	V
V _{ESD CDM}	Electrostatic handling CDM model	-	300	V
V _{ESD MM}	Electrostatic handling MM model	-	200	V
T _A	Operating Ambient Temperature Range	-40	+85	°C
T _C	Junction Temperature Range	-40	+125	°C
T _{STG}	Storage Temperature Range	-55	+150	°C
I _{lat}	Latchup-free input pin current ⁽²⁾	+/-100	-	mA

(1) Tested according to JESD22-A114A

(2) Static latch-up values are valid at maximum temperature according to JEDEC 78 specification

Table 4 - Absolute Maximum Ratings

2.2 Electrical Specifications

Table below applies to default registers values, unless otherwise specified. Typical values are given for T_A = +25°C, VDDM=VCC1=VCC2=3.3V.

Symbol	Description	Conditions	Min	Typ	Max	Unit
Supply						
VDDM	Main supply voltage	-	2.5	-	5.5	V
VCC1,2	I/O banks supply voltage	-	2.5	-	5.5	V
IDDM	Main supply current (I ² C inactive)	-	-	1	5	µA
ICC1,2	I/O banks supply current ⁽¹⁾	-	-	1	2	µA
I/Os set as Input						
VIH	High level input voltage	-	0.7* VCC1,2	-	VCC1,2 +0.3	V
VIL	Low level input voltage	-	-0.4	-	0.3* VCC1,2	V
VHYS	Hysteresis of Schmitt trigger	-	-	0.1* VCC1,2	-	V
ILEAK	Input leakage current	Assuming no active pull-up/down	-1.5	-	1.5	µA
CI	Input capacitance	-	-	-	10	pF
I/Os set as Output						
VOH	High level output voltage	-	VCC1,2 - 0.3	-	VCC1,2	V
VOL	Low level output voltage	-	-0.4	-	0.3	V
IOH	High level output source current	-	-	-	8	mA
IOL	Low level output sink current for the high sink I/Os	-	-	-	24	mA
	Low level output sink current for the other I/Os.	-	-	-	12	mA
t _{PV}	Output data valid timing	Cf. Figure 9	-	-	1.5	µs
NINT (Output)						
VOL	Low level output voltage	-	-	-	0.3	V
IOL _M	Low level output sink current	-	-	-	12	mA
t _{IV}	Interrupt valid timing	From input data change	-	-	1	µs
t _{IR}	Interrupt reset timing	From RegInterruptSource clearing	-	-	2	µs

WIRELESS & SENSING

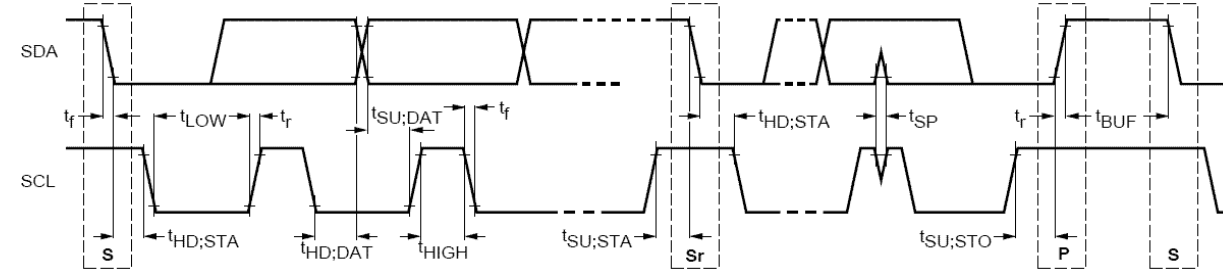
Symbol	Description	Conditions	Min	Typ	Max	Unit
NRESET (Input/Output)						
VOL	Low level output voltage	-	-	-	0.3	V
IOL _M	Low level output sink current	-	-	-	12	mA
VIH _{MR}	High level input voltage	-	0.7* VDDM	-	5.5	V
VIL _M	Low level input voltage	-	-0.4	-	0.3* VDDM	V
VHYS _M	Hysteresis of Schmitt trigger	-	-	0.1* VDDM	-	V
ILEAK	Input leakage current	-	-1.5	-	1.5	µA
CI	Input capacitance	-	-	-	10	pF
VPOR	Power-On-Reset voltage	Cf. Figure 7	0.7	-	0.9	V
VDROPH	High brown-out voltage	Cf. Figure 7	-	VDDM-1	-	V
VDROPL	Low brown-out voltage	Cf. Figure 7	-	0.2	-	V
t _{RESET}	Reset time	Cf. Figure 7	-	-	7	ms
t _{PULSE}	Reset pulse from host uC	Cf. Figure 7	300	-	-	ns
ADDR (Input)						
VIH _{MA}	High level input voltage	-	0.7* VDDM	-	VDDM +0.3	V
VIL _M	Low level input voltage	-	-0.4	-	0.3* VDDM	V
VHYS _M	Hysteresis of Schmitt trigger	-	-	0.1* VDDM	-	V
ILEAK	Input leakage current	-	-1.5	-	1.5	µA
CI	Input capacitance	-	-	-	10	pF
SCL (Input) and SDA (Input/Output) ⁽²⁾						
Interface complies with slave F/S mode I ² C interface as described by Philips I ² C specification version 2.1 dated January, 2000. Please refer to that document for more detailed I ² C specifications.						
						
VOL	Low level output voltage	-	-	-	0.3	V
IOL _M	Low level output sink current	-	-	-	12	mA
VIH _{MR}	High level input voltage	-	0.7* VDDM	-	5.5	V
VIL _M	Low level input voltage	-	-0.4	-	0.3* VDDM	V
f _{SCL}	SCL clock frequency	-	0	-	400	kHz
t _{HD:STA}	Hold time (repeated) START condition	-	0.6	-	-	µs
t _{LOW}	LOW period of the SCL clock	-	1.3	-	-	µs
t _{HIGH}	HIGH period of the SCL clock	-	0.6	-	-	µs
t _{SU:STA}	Set-up time for a repeated START condition	-	0.6	-	-	µs
t _{HD:DAT}	Data hold time	-	0 ⁽³⁾	-	0.9 ⁽⁴⁾	µs
t _{SU:DAT}	Data set-up time	-	100 ⁽⁵⁾	-	-	
t _r	Rise time of both SDA and SCL signals	-	20+0.1C _b ⁽⁶⁾	-	300	ns
t _f	Fall time of both SDA and SCL signals	-	20+0.1C _b ⁽⁶⁾	-	300	ns
t _{SU:STO}	Set-up time for STOP condition	-	0.6	-	-	µs

WIRELESS & SENSING

Symbol	Description	Conditions	Min	Typ	Max	Unit
t_{BUF}	Bus free time between a STOP and START condition	-	1.3	-	-	μ s
C_b	Capacitive load for each bus line	-	-	-	400	pF
V_{nL}	Noise margin at the LOW level for each connected device (including hysteresis)	-	$0.1 \cdot V_{DDM}$	-	-	V
V_{nH}	Noise margin at the HIGH level for each connected device (including hysteresis)	-	$0.2 \cdot V_{DDM}$	-	-	V
Miscellaneous						
RPULL	Programmable pull-up/down resistors for IO[0-7]	-	-	60	-	k Ω
t_{PLD}	PLD propagation delay	$V_{CC1,2} \text{ \& \ } V_{DDM} = 5V$	-	-	25	ns

(1) Assuming no load connected to outputs and inputs fixed to $V_{CC1,2}$ or GND.

(2) All values referred to $V_{IHMR \ min}$ and $V_{ILM \ max}$ levels.

(3) A device must internally provide a hold time of at least 300ns for the SDA signal (referred to $V_{IHMR \ min}$) to bridge the undefined region of the falling edge of SCL.

(4) The maximum $t_{HD;DAT}$ has only to be met if the device does not stretch the LOW period (t_{LOW}) of the SCL signal.

(5) A Fast-mode I²C-bus device can be used in a Standard-mode I²C-bus system, but the requirement $t_{SU;DAT} \geq 250$ ns must then be met.

This will automatically be the case if the device does not stretch the LOW period of the SCL signal.

If such a device does stretch the LOW period of the SCL signal, it must output the next data bit to the SDA line $t_{r \ max} + t_{SU;DAT} = 1000 + 250 = 1250$ ns (according to the Standard-mode I²C-bus specification) before the SCL line is released.

(6) C_b = total capacitance of one bus line in pF. If mixed with Hs-mode devices, faster fall-times are allowed.

Table 5 – Electrical Specifications

WIRELESS & SENSING

3 TYPICAL OPERATING CHARACTERISTICS

Figures below apply to default registers values, Tamb, unless otherwise specified.

3.1 IDDM vs. VDDM

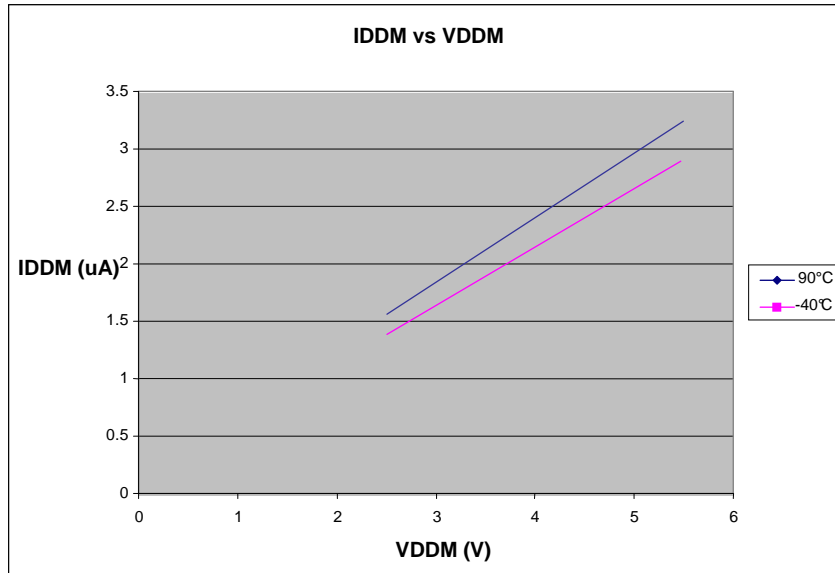

3.2 VOL vs. IOL

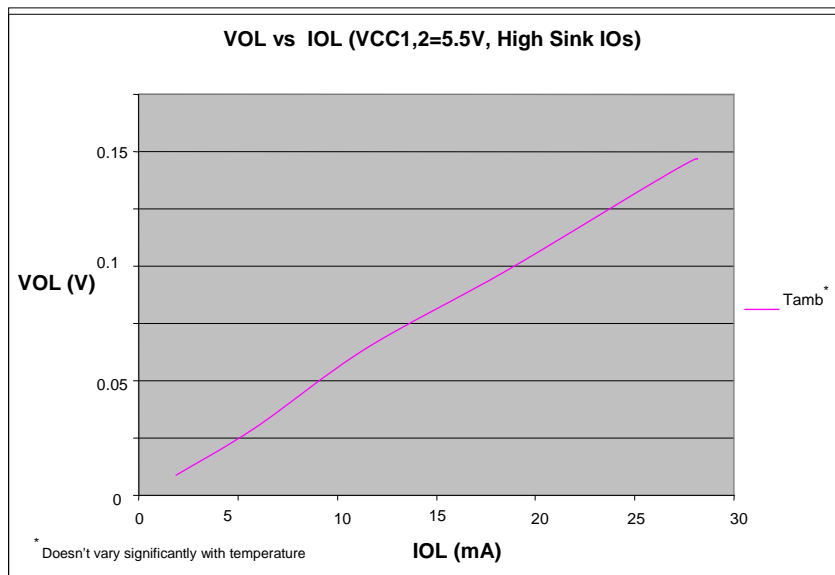

WIRELESS & SENSING

3.3 VOH vs. IOH

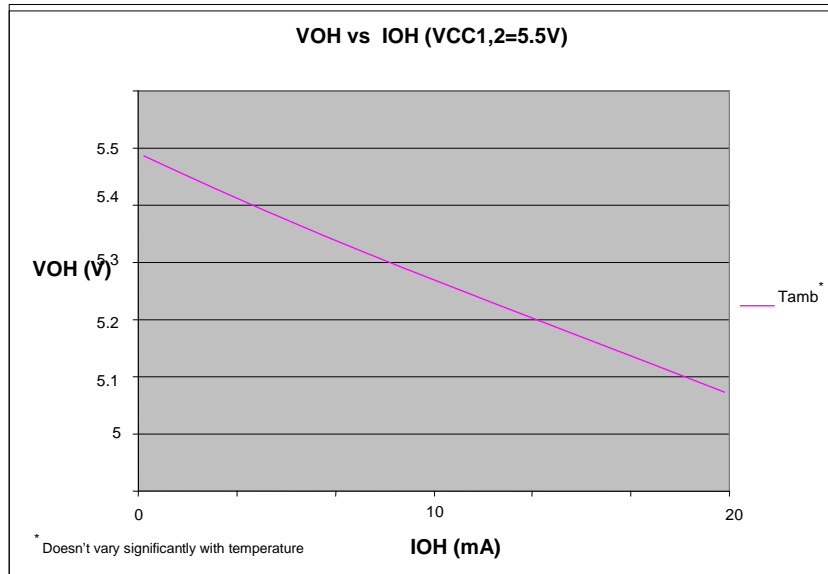

WIRELESS & SENSING

4 BLOCK DETAILED DESCRIPTION

4.1 SX1504 4-channel GPIO

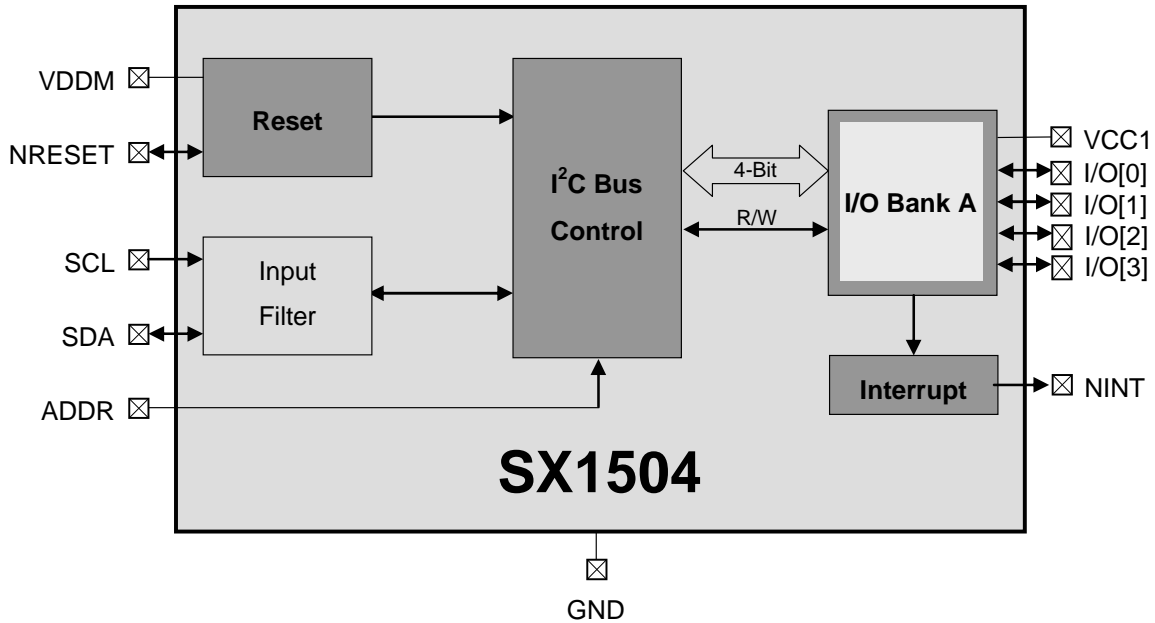

Figure 4 – SX1504 Block Diagram

4.2 SX1505 8-channel GPIO

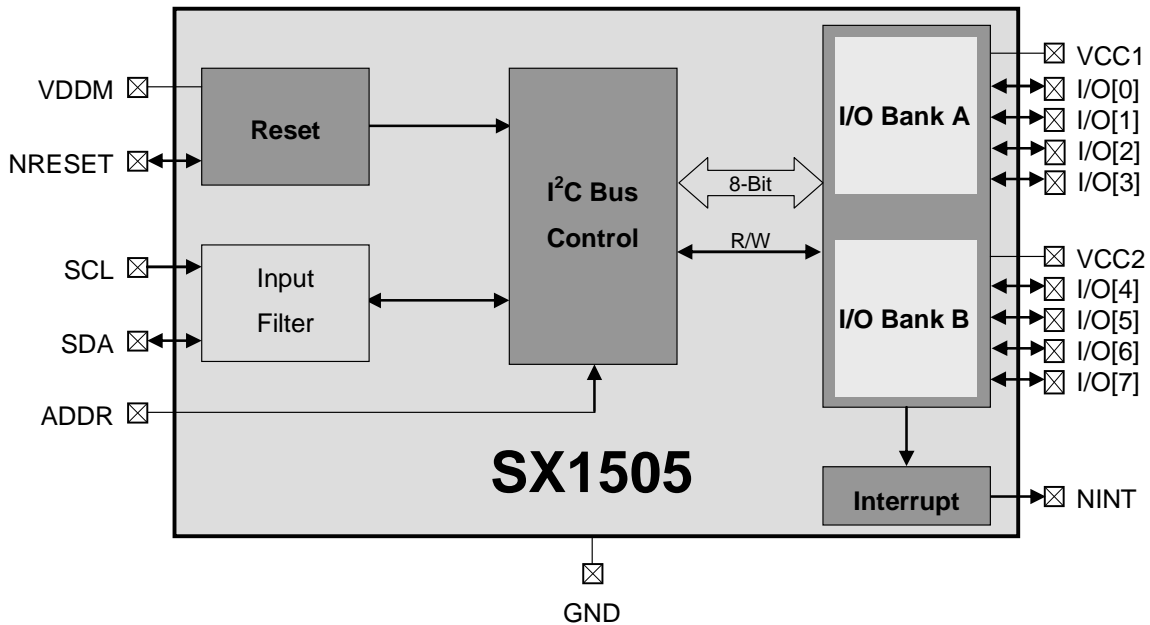

Figure 5 – SX1505 Block Diagram

WIRELESS & SENSING

4.3 SX1506 16-channel GPIO

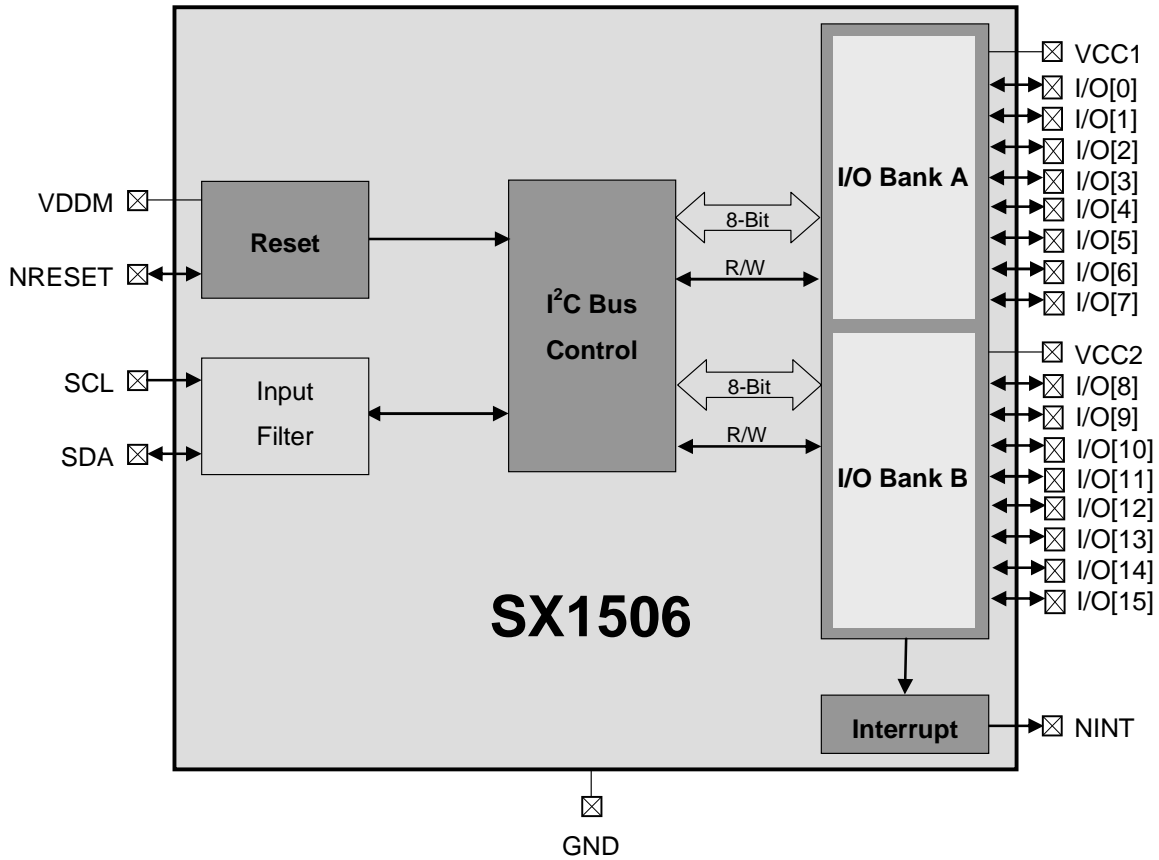

Figure 6 – SX1506 Block Diagram

4.4 Reset (NRESET)

The SX1504, SX1505 and SX1506 generate their own power on reset signal after a power supply is connected to the VDDM pin. The reset signal is made available for the user at the pin NRESET. The rising edge of the NRESET indicates that the startup sequence of the SX1504, SX1505 or SX1506 has finished. NRESET must be connected to VDDM (or greater) either directly, or via a resistor.

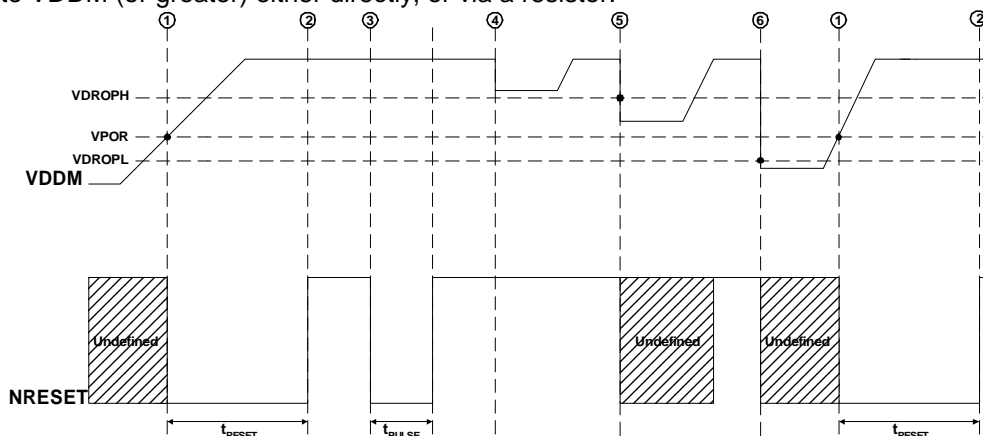

Figure 7 – Power-On / Brown-out Reset Conditions

1. Device behavior is undefined until VDDM rises above VPOR, at which point NRESET is driven to GND by the SX1504, SX1505 or SX1506.
2. After t_{RESET} , NRESET is released (high-impedance) by the SX1504, SX1505 or SX1506 to allow it to be pulled high by an external resistor.
3. In operation, the SX1504, SX1505 and SX1506 may be reset at anytime by an external device driving NRESET low during t_{PULSE} . Chip can be accessed normally again after NRESET rising edge.

WIRELESS & SENSING

4. During a brown-out event, if VDDM drops above VDROPH a reset will not occur.
5. During a brown-out event, if VDDM drops between VDROPH and VDROPL a reset may occur.
6. During a brown-out event, if VDDM drops below VDROPL a reset will occur next time VPOR is crossed.

Please note that a brown-out event is defined as a transient event on VDDM. If VDDM is attached to a battery, then the gradual decay of the battery voltage will not be interpreted as a brown-out event.

Please also note that a sharp rise in VDDM (> 1V/us) may induce a circuit reset.

4.5 2-Wire Interface (I²C)

The SX1504, SX1505 and SX1506 2-wire interface (I²C compliant) operates only in slave mode. In this configuration, the device has one or two device addresses defined by ADDR pin.

Device	ADDR Pin	I ² C Address	Description
SX1504 & SX1505	0	0x20 (0100000)	First address of the 2-wire interface
	1	0x21 (0100001)	Second address of the 2-wire interface
SX1506		0x20 (0100000)	Fixed address of the 2-wire interface

Table 6 - 2-Wire Interface Address

2 lines are used to exchange data between an external master host and the slave device:

- **SCL** : Serial CLock
- **SDA** : Serial DAta

The SX1504, SX1505 and SX1506 are read-write slave-mode I²C devices and comply with the Philips I²C standard Version 2.1 dated January, 2000. The SX1504, SX1505 and SX1506 have respectively 12, 16, and 31 user-accessible internal 8-bit registers. The I²C interface has been designed for program flexibility, in that once the slave address has been sent to the SX1504, SX1505 or SX1506 enabling it to be a slave transmitter/receiver, any register can be written or read independently of each other. While there is no auto increment/decrement capability in the SX1504 and SX1505 I²C logic, a tight software loop can be designed to access the next register independent of which register you begin accessing. SX1506 implements auto increment capability. The start and stop commands frame the data-packet and the repeat start condition is allowed if necessary.

Seven bit addressing is used and ten bit addressing is not allowed. Any general call address will be ignored by the SX1504, SX1505 and SX1506. The SX1504, SX1505 and SX1506 are not CBUS compatible and can operate in standard mode (100kbit/s) or fast mode (400kbit/s).

4.5.1 WRITE

The simplest format for an I²C write is given below. After the start condition [S], the slave address is sent, followed by an eighth bit indicating a write. The I²C then acknowledges that it is being addressed, and the master responds with an 8 bit data byte consisting of the register address. The slave acknowledges and the master sends the appropriate 8 bit data byte. Once again the slave acknowledges and the master terminates the transfer with the stop condition [P].

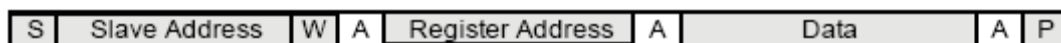

Master operations

SX1504, SX1505 or SX1506 operations (Slave)

S: Start Condition

W: Write = '0'

A: Acknowledge (sent by slave)

P: Stop condition

Slave Address: 7 bit

Register Address: 8 bit

Data: 8 bit

Figure 8 - 2-Wire Serial Interface, Write Register Operation

WIRELESS & SENSING

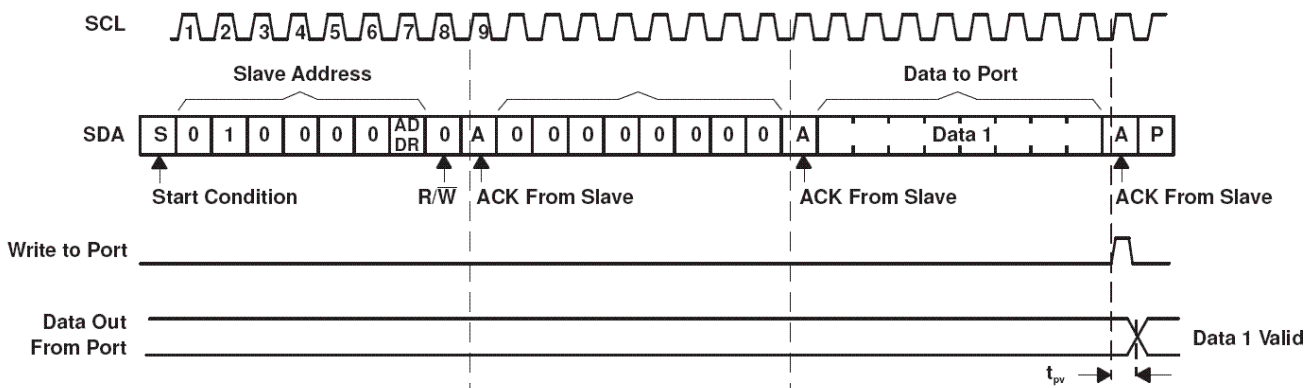
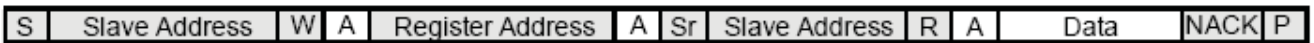

Figure 9 – Write RegData Register

Please note that SX1506 implements register address auto-increment i.e. after the Data ACK from Slave the master can write further bytes and the interface will handle the register address increment automatically. Finally the master terminates the transfer normally the stop condition [P].

4.5.2 READ

After the start condition [S], the slave address is sent, followed by an eighth bit indicating a write. The I²C then acknowledges that it is being addressed, and the master responds with an 8 bit data byte consisting of the register address. The slave acknowledges and the master sends the repeated start condition [Sr]. Once again, the slave address is sent, followed by an eighth bit indicating a read. The slave responds with an acknowledge and the previously addressed 8 bit data byte; the master then sends a non-acknowledge (NACK). Finally, the master terminates the transfer with the stop condition [P].



- Master operations
- SX1504, SX1505 or SX1506 operations (Slave)

- S: Start Condition
- W: Write = '0'
- R: Read = '1'
- A: Acknowledge (sent by slave)
- NACK: Non-Acknowledge (sent by master)
- Sr: Repeated Start Condition
- P: Stop condition
- Slave Address: 7 bit
- Register Address: 8 bit
- Data: 8 bit

Figure 10 - 2-Wire Serial Interface, Read Register Operation

Please note that SX1506 implements register address auto-increment i.e. after the Data byte from Slave the master can acknowledge (ACK) to indicate that it wants to read the next byte and the interface will handle the register address increment automatically. Finally the master terminates the transfer normally with a NACK followed by the stop condition [P].

4.5.3 READ - STOP separated format (SX1504 and SX1505 only)

When operating SX1504 or SX1505, stop-separated reads can also be used. This format allows a master to set up the register address pointer for a read and return to that slave at a later time to read the data. In this format the slave address followed by a write command are sent after a start [S] condition. The slave then acknowledges it is being addressed, and the master responds with the 8-bit register address. The master sends a Stop or Restart condition and may then address another slave. After performing other tasks, the master can send a start or restart condition to the slave with a read command. The slave acknowledges this request and returns the data from the register location that had previously been set up.

WIRELESS & SENSING

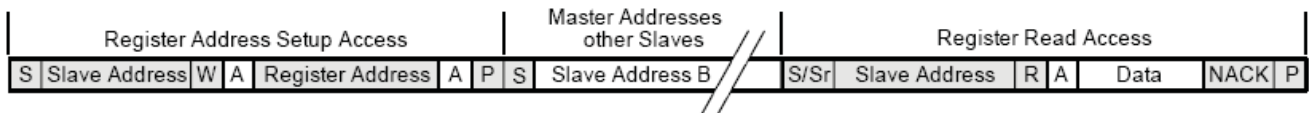

- Master operations
- SX1504, SX1505 or SX1506 operations (Slave)

S: Start Condition
W: Write = '0'
R: Read = '1'
A: Acknowledge (sent by slave)
NACK: Non-Acknowledge (sent by master)
Sr: Repeated Start Condition
P: Stop condition

Slave Address: 7 bit
Register Address: 8 bit
Data: 8 bit

Figure 11 - 2-Wire Serial Interface, Read – Stop Separated Mode Operation

4.6 Interrupt (NINT)

At start-up, the transition detection logic is reset, and NINT is released to a high-impedance state. The interrupt mask register is set to 0xFF, disabling the interrupt output for transitions on all I/O ports. The transition flags are cleared to indicate no data changes.

An interrupt NINT can be generated on any programmed combination of I/Os rising and/or falling edges through the RegInterruptMask and RegSense registers.

If needed, the I/Os which triggered the interrupt can then be identified by reading RegInterruptSource register.

When NINT is low (i.e. interrupt occurred), it can be reset back high (i.e. cleared) by writing 0xFF in RegInterruptSource (this will also clear corresponding bits in RegEventStatus register).

SX1506 also allows the interrupt to be cleared automatically when reading RegData register (Cf. RegAdvanced)

Example: We want to detect rising edge of I/O[1] on SX1505 (NINT will go low).

1. We enable interrupt on I/O[1] in RegInterruptMask
⇒ RegInterruptMask = "XXXXXX0X"

2. We set edge sense for I/O[1] in RegSense
⇒ RegSenseLow = "XXXX01XX"

4.7 Programmable Logic Functions (PLD)

The SX1504, SX1505 and SX1506 offer a unique fully programmable logic functions like a PLD to give more flexibility and reduce external logic gates used for standard applications.

Since the whole truth table is fully programmable, the SX1504, SX1505, and SX1506 can implement combinatory functions ranging from the basic AND/OR gates to the most complicated ones with up to four 3-to-1 PLDs or two 3-to-2 PLDs which can also be externally cascaded if needed.

In all cases, any IO not configured for PLD functionality retains its GPIO functionality while I/Os used by the PLD have their direction automatically set accordingly.

Please note that while RegDir corresponding bits are ignored for PLD operation they may still be set to input to access unused PLD inputs as normal GPI (PLD truth table can define some inputs to have no effect on PLD output) and/or generate interrupt based on any of the PLD inputs or outputs bits.

4.7.1 SX1504

The SX1504 I/Os can be configured to provide any combinational 2-to-1 logic function using I/O[0-2] whilst retaining GPIO capability on I/O[3] OR provide a combinational 3-to-1 decode function using all 4 I/O ports.

RegPLDMode 1:0	SX1504 I/Os			
	3	2	1	0
00	GPIO	GPIO	GPIO	GPIO
01	GPIO	PLD OUT	PLD IN	PLD IN
10	PLD OUT	PLD IN	PLD IN	PLD IN

Table 7 – SX1504 PLD Modes Settings

WIRELESS & SENSING

4.7.2 SX1505

The SX1505 I/Os can be configured as per the SX1504, and can additionally be configured to provide a 2-to-1 logic function on I/O[4-6], 3-to-1 logic function on I/O[4-7], or 3-to-2 logic decode on I/O[0-4].

RegPLDMode		SX1505 I/Os							
5:4	1:0	7	6	5	4	3	2	1	0
00	00	GPIO	GPIO	GPIO	GPIO	GPIO	GPIO	GPIO	GPIO
00	01	GPIO	GPIO	GPIO	GPIO	GPIO	PLD OUT	PLD IN	PLD IN
00	10	GPIO	GPIO	GPIO	GPIO	PLD OUT	PLD IN	PLD IN	PLD IN
00	11	GPIO	GPIO	GPIO	PLD OUT	PLD OUT	PLD IN	PLD IN	PLD IN
01	00	GPIO	PLD OUT	PLD IN	PLD IN	GPIO	GPIO	GPIO	GPIO
01	01	GPIO	PLD OUT	PLD IN	PLD IN	GPIO	PLD OUT	PLD IN	PLD IN
01	10	GPIO	PLD OUT	PLD IN	PLD IN	PLD OUT	PLD IN	PLD IN	PLD IN
01	11	GPIO	GPIO	GPIO	PLD OUT	PLD OUT	PLD IN	PLD IN	PLD IN
10	00	PLD OUT	PLD IN	PLD IN	PLD IN	GPIO	GPIO	GPIO	GPIO
10	01	PLD OUT	PLD IN	PLD IN	PLD IN	GPIO	PLD OUT	PLD IN	PLD IN
10	10	PLD OUT	PLD IN	PLD IN	PLD IN	PLD OUT	PLD IN	PLD IN	PLD IN
10	11	GPIO	GPIO	GPIO	PLD OUT	PLD OUT	PLD IN	PLD IN	PLD IN

Table 8 – SX1505 PLD Modes Settings

4.7.3 SX1506

Each of the two I/O banks of the SX1506 I/Os can be configured as per the SX1505.

RegPLDModeB		SX1506 I/Os							
5:4	1:0	15	14	13	12	11	10	9	8
00	00	GPIO	GPIO	GPIO	GPIO	GPIO	GPIO	GPIO	GPIO
00	01	GPIO	GPIO	GPIO	GPIO	GPIO	PLD OUT	PLD IN	PLD IN
00	10	GPIO	GPIO	GPIO	GPIO	PLD OUT	PLD IN	PLD IN	PLD IN
00	11	GPIO	GPIO	GPIO	PLD OUT	PLD OUT	PLD IN	PLD IN	PLD IN
01	00	GPIO	PLD OUT	PLD IN	PLD IN	GPIO	GPIO	GPIO	GPIO
01	01	GPIO	PLD OUT	PLD IN	PLD IN	GPIO	PLD OUT	PLD IN	PLD IN
01	10	GPIO	PLD OUT	PLD IN	PLD IN	PLD OUT	PLD IN	PLD IN	PLD IN
01	11	GPIO	GPIO	GPIO	PLD OUT	PLD OUT	PLD IN	PLD IN	PLD IN
10	00	PLD OUT	PLD IN	PLD IN	PLD IN	GPIO	GPIO	GPIO	GPIO
10	01	PLD OUT	PLD IN	PLD IN	PLD IN	GPIO	PLD OUT	PLD IN	PLD IN
10	10	PLD OUT	PLD IN	PLD IN	PLD IN	PLD OUT	PLD IN	PLD IN	PLD IN
10	11	GPIO	GPIO	GPIO	PLD OUT	PLD OUT	PLD IN	PLD IN	PLD IN

Table 9 – SX1506 PLD Modes Settings (Bank B)

RegPLDModeA		SX1506 I/Os							
5:4	1:0	7	6	5	4	3	2	1	0
00	00	GPIO	GPIO	GPIO	GPIO	GPIO	GPIO	GPIO	GPIO
00	01	GPIO	GPIO	GPIO	GPIO	GPIO	PLD OUT	PLD IN	PLD IN
00	10	GPIO	GPIO	GPIO	GPIO	PLD OUT	PLD IN	PLD IN	PLD IN
00	11	GPIO	GPIO	GPIO	PLD OUT	PLD OUT	PLD IN	PLD IN	PLD IN
01	00	GPIO	PLD OUT	PLD IN	PLD IN	GPIO	GPIO	GPIO	GPIO
01	01	GPIO	PLD OUT	PLD IN	PLD IN	GPIO	PLD OUT	PLD IN	PLD IN
01	10	GPIO	PLD OUT	PLD IN	PLD IN	PLD OUT	PLD IN	PLD IN	PLD IN
01	11	GPIO	GPIO	GPIO	PLD OUT	PLD OUT	PLD IN	PLD IN	PLD IN
10	00	PLD OUT	PLD IN	PLD IN	PLD IN	GPIO	GPIO	GPIO	GPIO
10	01	PLD OUT	PLD IN	PLD IN	PLD IN	GPIO	PLD OUT	PLD IN	PLD IN
10	10	PLD OUT	PLD IN	PLD IN	PLD IN	PLD OUT	PLD IN	PLD IN	PLD IN
10	11	GPIO	GPIO	GPIO	PLD OUT	PLD OUT	PLD IN	PLD IN	PLD IN

Table 10 – SX1506 PLD Modes Settings (Bank B)

WIRELESS & SENSING

4.7.4 Tutorial

The generic method described in this paragraph can be applied to any of the SX1504, SX1505 or SX1506.

Example: We want to implement an AND gate between I/O[0] and IO[1] on SX1505

1. Identify in the tables above the RegPLDMode setting to be programmed.
What we need corresponds to the second line of the SX1505 PLD Table => RegPLDMode = "xx00xx01"
2. Fill corresponding RegPLDTableX with the wanted truth table.
As mentioned in RegPLDMode description, using PLD 2-to-1 mode on I/O[0-2] implies to fill the truth table located in RegPLDTable0(3:0)

I/O[1]	I/O[0]	I/O[2]
0	0	0
0	1	0
1	0	0
1	1	1

=> RegPLDTable0 = "xxx**1000**"

WIRELESS & SENSING

5 CONFIGURATION REGISTERS

5.1 SX1504 4-channel GPIO

Address	Name	Description	Default
0x00	RegData	Data register	1111 1111
0x01	RegDir	Direction register	1111 1111
0x02	RegPullUp	Pull-up register	0000 0000
0x03	RegPullDown	Pull-down register	0000 0000
0x04	Reserved	Unused	XXXX XXXX
0x05	RegInterruptMask	Interrupt mask register	1111 1111
0x06	RegSenseHigh	Unused	XXXX XXXX
0x07	RegSenseLow	Sense register	0000 0000
0x08	RegInterruptSource	Interrupt source register	0000 0000
0x09	RegEventStatus	Event status register	0000 0000
0x10	RegPLDMode	PLD mode register	0000 0000
0x11	RegPLDTable0	PLD truth table 0	0000 0000
0x12	RegPLDTable1	Unused	XXXX XXXX
0x13	RegPLDTable2	PLD truth table 2	0000 0000
0x14	RegPLDTable3	Unused	XXXX XXXX
0x15	RegPLDTable4	Unused	XXXX XXXX

Bits set as output take '1' as default value.

Table 11 – SX1504 Configuration Registers Overview

Addr	Name	Default	Bits	Description
0x00	RegData	0xFF	7:4	Reserved. Must be set to 1 (default value)
			3:0	Write: Data to be output to the output-configured IOs Read: Data seen at the IOs, independent of the direction configured.
0x01	RegDir	0xFF	7:4	Reserved. Must be set to 1 (default value)
			3:0	Configures direction for each IO. 0 : IO is configured as an output 1 : IO is configured as an input
0x02	RegPullUp	0x00	7:4	Reserved. Must be set to 0 (default value)
			3:0	Enables the pull-up for each IO 0 : Pull-up is disabled 1 : Pull-up is enabled
0x03	RegPullDown	0x00	7:4	Reserved. Must be set to 0 (default value)
			3:0	Enables the pull-down for each IO 0 : Pull-down is disabled 1 : Pull-down is enabled
0x04	Reserved	0xFF	7:0	Unused
0x05	RegInterruptMask	0xFF	7:4	Reserved. Must be set to 1 (default value)
			3:0	Configures which [input-configured] IO will trigger an interrupt on NINT pin 0 : An event on this IO will trigger an interrupt 1 : An event on this IO will NOT trigger an interrupt
0x06	RegSenseHigh	0xFF	7:0	Unused
0x07	RegSenseLow	0x00	7:6	Edge sensitivity of I/O[3]
			5:4	Edge sensitivity of I/O[2]
			3:2	Edge sensitivity of I/O[1]
			1:0	Edge sensitivity of I/O[0]
0x08	RegInterruptSource	0x00	7:4	Reserved. Must be set to 0 (default value)
			3:0	Interrupt source (from IOs set in RegInterruptMask) 0 : No interrupt has been triggered by this IO 1 : An interrupt has been triggered by this IO (an event as configured in relevant RegSense register occurred). Writing '1' clears the bit in RegInterruptSource and in RegEventStatus. When all bits are cleared, NINT signal goes back high.
0x09		0x00	7:4	Reserved. Must be set to 0 (default value)

WIRELESS & SENSING

Addr	Name	Default	Bits	Description
	RegEventStatus		3:0	Event status of all IOs. 0 : No event has occurred on this IO 1 : An event has occurred on this IO (an edge as configured in relevant RegSense register occurred). Writing '1' clears the bit in RegEventStatus and in RegInterruptSource if relevant. If the edge sensitivity of the IO is changed, the bit(s) will be cleared automatically
0x10	RegPLDMode	0x00	7:2	Reserved. Must be set to 0 (default value)
			1:0	PLDMode 00 : PLD disabled – Normal GPIO mode for I/O[3:0] 01 : PLD 2-to-1 mode – I/O[2] is a decode of I/O[1:0] as defined in RegPLDTable0 10 : PLD 3-to-1 mode – I/O[3] is a decode of I/O[2:0] as defined in RegPLDTable2 11 : Not used
0x11	RegPLDTable0	0x00	7:4	Reserved. Must be set to 0 (default value)
			3	Value to be output on I/O[2] when I/O[1:0] = 11
			2	Value to be output on I/O[2] when I/O[1:0] = 10
			1	Value to be output on I/O[2] when I/O[1:0] = 01
			0	Value to be output on I/O[2] when I/O[1:0] = 00
0x12	RegPLDTable1	0xXX	7:0	Unused
0x13	RegPLDTable2	0x00	7	Value to be output on I/O[3] when I/O[2:0] = 111
			6	Value to be output on I/O[3] when I/O[2:0] = 110
			5	Value to be output on I/O[3] when I/O[2:0] = 101
			4	Value to be output on I/O[3] when I/O[2:0] = 100
			3	Value to be output on I/O[3] when I/O[2:0] = 011
			2	Value to be output on I/O[3] when I/O[2:0] = 010
			1	Value to be output on I/O[3] when I/O[2:0] = 001
			0	Value to be output on I/O[3] when I/O[2:0] = 000
0x14	RegPLDTable3	0xXX	7:0	Unused
0x15	RegPLDTable4	0xXX	7:0	Unused

Table 12 – SX1504 Configuration Registers Description

5.2 SX1505 8-channel GPIO

Address	Name	Description	Default
0x00	RegData	Data register	1111 1111
0x01	RegDir	Direction register	1111 1111
0x02	RegPullUp	Pull-up register	0000 0000
0x03	RegPullDown	Pull-down register	0000 0000
0x04	Reserved	Unused	XXXX XXXX
0x05	RegInterruptMask	Interrupt mask register	1111 1111
0x06	RegSenseHigh	Sense register for I/O[7:4]	0000 0000
0x07	RegSenseLow	Sense register for I/O[3:0]	0000 0000
0x08	RegInterruptSource	Interrupt source register	0000 0000
0x09	RegEventStatus	Event status register	0000 0000
0x10	RegPLDMode	PLD mode register	0000 0000
0x11	RegPLDTable0	PLD truth table 0	0000 0000
0x12	RegPLDTable1	PLD truth table 1	0000 0000
0x13	RegPLDTable2	PLD truth table 2	0000 0000
0x14	RegPLDTable3	PLD truth table 3	0000 0000
0x15	RegPLDTable4	PLD truth table 4	0000 0000

Bits set as output take "1" as default value.

Table 13 – SX1505 Configuration Registers Overview

Addr	Name	Default	Bits	Description
0x00	RegData	0xFF	7:0	Write: Data to be output to the output-configured IOs Read: Data seen at the IOs, independent of the direction configured.
0x01	RegDir	0xFF	7:0	Configures direction for each IO. 0 : IO is configured as an output 1 : IO is configured as an input
0x02	RegPullUp	0x00	7:0	Enables the pull-up for each IO 0 : Pull-up is disabled 1 : Pull-up is enabled
0x03	RegPullDown	0x00	7:0	Enables the pull-down for each IO 0 : Pull-down is disabled 1 : Pull-down is enabled

WIRELESS & SENSING

Addr	Name	Default	Bits	Description	
0x04	Reserved	0xFF	7:0	Unused	
0x05	RegInterruptMask	0xFF	7:0	Configures which [input-configured] IO will trigger an interrupt on NINT pin 0 : An event on this IO will trigger an interrupt 1 : An event on this IO will NOT trigger an interrupt	
0x06	RegSenseHigh	0x00	7:6	Edge sensitivity of I/O[7]	00 : None 01 : Rising 10 : Falling 11 : Both
			5:4	Edge sensitivity of I/O[6]	
			3:2	Edge sensitivity of I/O[5]	
			1:0	Edge sensitivity of I/O[4]	
0x07	RegSenseLow	0x00	7:6	Edge sensitivity of I/O[3]	00 : None 01 : Rising 10 : Falling 11 : Both
			5:4	Edge sensitivity of I/O[2]	
			3:2	Edge sensitivity of I/O[1]	
			1:0	Edge sensitivity of I/O[0]	
0x08	RegInterruptSource	0x00	7:0	Interrupt source (from IOs set in RegInterruptMask) 0 : No interrupt has been triggered by this IO 1 : An interrupt has been triggered by this IO (an event as configured in relevant RegSense register occurred). Writing '1' clears the bit in RegInterruptSource and in RegEventStatus When all bits are cleared, NINT signal goes back high.	
0x09	RegEventStatus	0x00	7:0	Event status of all IOs. 0 : No event has occurred on this IO 1 : An event has occurred on this IO (an edge as configured in relevant RegSense register occurred). Writing '1' clears the bit in RegEventStatus and in RegInterruptSource if relevant. If the edge sensitivity of the IO is changed, the bit(s) will be cleared automatically	
0x10	RegPLDMode	0x00	7:6	Reserved. Must be set to 0 (default value)	
			5:4	PLDModeHigh (applies to I/O[7:4]) 00 : PLD disabled – Normal GPIO mode for I/O[7:4] 01 : PLD 2-to-1 mode – I/O[6] is a decode of I/O[5:4] as defined in RegPLDTable0 10 : PLD 3-to-1 mode – I/O[7] is a decode of I/O[6:4] as defined in RegPLDTable1 11 : Reserved	
			3:2	Reserved. Must be set to 0 (default value)	
			1:0	PLDModeLow (applies to I/O[3:0]) 00 : PLD disabled – Normal GPIO mode for I/O[3:0] 01 : PLD 2-to-1 mode – I/O[2] is a decode of I/O[1:0] as defined in RegPLDTable0 10 : PLD 3-to-1 mode – I/O[3] is a decode of I/O[2:0] as defined in RegPLDTable2 11 : PLD 3-to-2 mode – I/O[4:3] are decodes of I/O[2:0] as defined in RegPLDTable3 and RegPLDTable4	
0x11	RegPLDTable0	0x00	7	Value to be output on I/O[6] when I/O[5:4] = 11	Applies only when PLDModeHigh is set to PLD 2-to-1 mode
			6	Value to be output on I/O[6] when I/O[5:4] = 10	
			5	Value to be output on I/O[6] when I/O[5:4] = 01	
			4	Value to be output on I/O[6] when I/O[5:4] = 00	
			3	Value to be output on I/O[2] when I/O[1:0] = 11	Applies only when PLDModeLow is set to PLD 2-to-1 mode
			2	Value to be output on I/O[2] when I/O[1:0] = 10	
			1	Value to be output on I/O[2] when I/O[1:0] = 01	
			0	Value to be output on I/O[2] when I/O[1:0] = 00	
0x12	RegPLDTable1	0x00	7	Value to be output on I/O[7] when I/O[6:4] = 111	Applies only when PLDModeHigh is set to PLD 3-to-1 mode
			6	Value to be output on I/O[7] when I/O[6:4] = 110	
			5	Value to be output on I/O[7] when I/O[6:4] = 101	
			4	Value to be output on I/O[7] when I/O[6:4] = 100	
			3	Value to be output on I/O[7] when I/O[6:4] = 011	
			2	Value to be output on I/O[7] when I/O[6:4] = 010	
			1	Value to be output on I/O[7] when I/O[6:4] = 001	
			0	Value to be output on I/O[7] when I/O[6:4] = 000	
0x13	RegPLDTable2	0x00	7	Value to be output on I/O[3] when I/O[2:0] = 111	Applies only when PLDModeLow is set to PLD 3-to-1 mode
			6	Value to be output on I/O[3] when I/O[2:0] = 110	
			5	Value to be output on I/O[3] when I/O[2:0] = 101	
			4	Value to be output on I/O[3] when I/O[2:0] = 100	
			3	Value to be output on I/O[3] when I/O[2:0] = 011	
			2	Value to be output on I/O[3] when I/O[2:0] = 010	
			1	Value to be output on I/O[3] when I/O[2:0] = 001	
			0	Value to be output on I/O[3] when I/O[2:0] = 000	
0x14	RegPLDTable3	0x00	7	Value to be output on I/O[4] when I/O[2:0] = 111	Applies only when PLDModeLow is set to PLD 3-to-2 mode
			6	Value to be output on I/O[4] when I/O[2:0] = 110	
			5	Value to be output on I/O[4] when I/O[2:0] = 101	

WIRELESS & SENSING

Addr	Name	Default	Bits	Description
0x15	RegPLDTable4	0x00	4	Value to be output on I/O[4] when I/O[2:0] = 100
			3	Value to be output on I/O[4] when I/O[2:0] = 011
			2	Value to be output on I/O[4] when I/O[2:0] = 010
			1	Value to be output on I/O[4] when I/O[2:0] = 001
			0	Value to be output on I/O[4] when I/O[2:0] = 000
			7	Value to be output on I/O[3] when I/O[2:0] = 111
			6	Value to be output on I/O[3] when I/O[2:0] = 110
			5	Value to be output on I/O[3] when I/O[2:0] = 101
			4	Value to be output on I/O[3] when I/O[2:0] = 100
			3	Value to be output on I/O[3] when I/O[2:0] = 011
			2	Value to be output on I/O[3] when I/O[2:0] = 010
			1	Value to be output on I/O[3] when I/O[2:0] = 001
			0	Value to be output on I/O[3] when I/O[2:0] = 000

Applies only when PLDModeLow is set to PLD 3-to-2 mode

Table 14 – SX1505 Configuration Registers Description

5.3 SX1506 16-channel GPIO

Address	Name	Description	Default
0x00	RegDataB	Data register for Bank B I/O[15:8]	1111 1111
0x01	RegDataA	Data register for Bank A I/O[7:0]	1111 1111
0x02	RegDirB	Direction register for Bank B I/O[15:8]	1111 1111
0x03	RegDirA	Direction register for Bank A I/O[7:0]	1111 1111
0x04	RegPullUpB	Pull-up register for Bank B I/O[15:8]	0000 0000
0x05	RegPullUpA	Pull-up register for Bank A I/O[7:0]	0000 0000
0x06	RegPullDownB	Pull-down register for Bank B I/O[15:8]	0000 0000
0x07	RegPullDownA	Pull-down register for Bank A I/O[7:0]	0000 0000
0x08	RegInterruptMaskB	Interrupt mask register for Bank B I/O[15:8]	1111 1111
0x09	RegInterruptMaskA	Interrupt mask register for Bank A I/O[7:0]	1111 1111
0x0A	RegSenseHighB	Sense register for I/O[15:12]	0000 0000
0x0B	RegSenseHighA	Sense register for I/O[7:4]	0000 0000
0x0C	RegSenseLowB	Sense register for I/O[11:8]	0000 0000
0x0D	RegSenseLowA	Sense register for I/O[3:0]	0000 0000
0x0E	RegInterruptSourceB	Interrupt source register for Bank B I/O[15:8]	0000 0000
0x0F	RegInterruptSourceA	Interrupt source register for Bank A I/O[7:0]	0000 0000
0x10	RegEventStatusB	Event status register for Bank B I/O[15:8]	0000 0000
0x11	RegEventStatusA	Event status register for Bank A I/O[7:0]	0000 0000
0x20	RegPLDModeB	PLD mode register for Bank B I/O[15:8]	0000 0000
0x21	RegPLDModeA	PLD mode register for Bank A I/O[7:0]	0000 0000
0x22	RegPLDTable0B	PLD truth table 0 for Bank B I/O[15:8]	0000 0000
0x23	RegPLDTable0A	PLD truth table 0 for Bank A I/O[7:0]	0000 0000
0x24	RegPLDTable1B	PLD truth table 1 for Bank B I/O[15:8]	0000 0000
0x25	RegPLDTable1A	PLD truth table 1 for Bank A I/O[7:0]	0000 0000
0x26	RegPLDTable2B	PLD truth table 2 for Bank B I/O[15:8]	0000 0000
0x27	RegPLDTable2A	PLD truth table 2 for Bank A I/O[7:0]	0000 0000
0x28	RegPLDTable3B	PLD truth table 3 for Bank B I/O[15:8]	0000 0000
0x29	RegPLDTable3A	PLD truth table 3 for Bank A I/O[7:0]	0000 0000
0x2A	RegPLDTable4B	PLD truth table 4 for Bank B I/O[15:8]	0000 0000
0x2B	RegPLDTable4A	PLD truth table 4 for Bank A I/O[7:0]	0000 0000
0xAD	RegAdvanced	Advanced settings register	0000 0000

bits set as output take '1' as default value.

Table 15 – SX1506 Configuration Registers Overview

Addr	Name	Default	Bits	Description
0x00	RegDataB	0xFF	7:0	Write: Data to be output to the output-configured IOs Read: Data seen at the IOs, independent of the direction configured.
0x01	RegDataA	0xFF	7:0	Write: Data to be output to the output-configured IOs Read: Data seen at the IOs, independent of the direction configured.
0x02	RegDirB	0xFF	7:0	Configures direction for each IO. 0 : IO is configured as an output 1 : IO is configured as an input

WIRELESS & SENSING

Addr	Name	Default	Bits	Description	
0x03	RegDirA	0xFF	7:0	Configures direction for each IO. 0 : IO is configured as an output 1 : IO is configured as an input	
0x04	RegPullUpB	0x00	7:0	Enables the pull-up for each IO 0 : Pull-up is disabled 1 : Pull-up is enabled	
0x05	RegPullUpA	0x00	7:0	Enables the pull-up for each IO 0 : Pull-up is disabled 1 : Pull-up is enabled	
0x06	RegPullDownB	0x00	7:0	Enables the pull-down for each IO 0 : Pull-down is disabled 1 : Pull-down is enabled	
0x07	RegPullDownA	0x00	7:0	Enables the pull-down for each IO 0 : Pull-down is disabled 1 : Pull-down is enabled	
0x08	RegInterruptMaskB	0xFF	7:0	Configures which [input-configured] IO will trigger an interrupt on NINT pin 0 : An event on this IO will trigger an interrupt 1 : An event on this IO will NOT trigger an interrupt	
0x09	RegInterruptMaskA	0xFF	7:0	Configures which [input-configured] IO will trigger an interrupt on NINT pin 0 : An event on this IO will trigger an interrupt 1 : An event on this IO will NOT trigger an interrupt	
0x0A	RegSenseHighB	0x00	7:6	Edge sensitivity of I/O[15]	00 : None 01 : Rising 10 : Falling 11 : Both
			5:4	Edge sensitivity of I/O[14]	
			3:2	Edge sensitivity of I/O[13]	
			1:0	Edge sensitivity of I/O[12]	
0x0B	RegSenseHighA	0x00	7:6	Edge sensitivity of I/O[7]	00 : None 01 : Rising 10 : Falling 11 : Both
			5:4	Edge sensitivity of I/O[6]	
			3:2	Edge sensitivity of I/O[5]	
			1:0	Edge sensitivity of I/O[4]	
0x0C	RegSenseLowB	0x00	7:6	Edge sensitivity of I/O[11]	00 : None 01 : Rising 10 : Falling 11 : Both
			5:4	Edge sensitivity of I/O[10]	
			3:2	Edge sensitivity of I/O[9]	
			1:0	Edge sensitivity of I/O[8]	
0x0D	RegSenseLowA	0x00	7:6	Edge sensitivity of I/O[3]	00 : None 01 : Rising 10 : Falling 11 : Both
			5:4	Edge sensitivity of I/O[2]	
			3:2	Edge sensitivity of I/O[1]	
			1:0	Edge sensitivity of I/O[0]	
0x0E	RegInterruptSourceB	0x00	7:0	Interrupt source (from IOs set in RegInterruptMaskB) 0 : No interrupt has been triggered by this IO 1 : An interrupt has been triggered by this IO (an event as configured in relevant RegSense register occurred). Writing '1' clears the bit in RegInterruptSourceB and in RegEventStatusB When all bits of both RegInterruptSourceA/B are cleared, NINT signal goes back high.	
0x0F	RegInterruptSourceA	0x00	7:0	Interrupt source (from IOs set in RegInterruptMaskA) 0 : No interrupt has been triggered by this IO 1 : An interrupt has been triggered by this IO (an event as configured in relevant RegSense register occurred). Writing '1' clears the bit in RegInterruptSourceA and in RegEventStatusA When all bits of both RegInterruptSourceA/B are cleared, NINT signal goes back high.	
0x10	RegEventStatusB	0x00	7:0	Event status of all IOs. 0 : No event has occurred on this IO 1 : An event has occurred on this IO (an edge as configured in relevant RegSense register occurred). Writing '1' clears the bit in RegEventStatusB and in RegInterruptSourceB if relevant. If the edge sensitivity of the IO is changed, the bit(s) will be cleared automatically	
0x11	RegEventStatusA	0x00	7:0	Event status of all IOs. 0 : No event has occurred on this IO 1 : An event has occurred on this IO (an edge as configured in relevant RegSense register occurred). Writing '1' clears the bit in RegEventStatusA and in RegInterruptSourceA if relevant. If the edge sensitivity of the IO is changed, the bit(s) will be cleared automatically	
0x20		0x00	7:6	Reserved. Must be set to 0 (default value)	

WIRELESS & SENSING

Addr	Name	Default	Bits	Description	
	RegPLDModeB		5:4	PLDModeHighB (applies to I/O[15:12]) 00 : PLD disabled – Normal GPIO mode for I/O[15:12] 01 : PLD 2-to-1 mode – I/O[14] is a decode of I/O[13:12] as defined in RegPLDTable0B 10 : PLD 3-to-1 mode – I/O[15] is a decode of I/O[14:12] as defined in RegPLDTable1B 11 : Reserved	
			3:2	Reserved. Must be set to 0 (default value)	
			1:0	PLDModeLowB (applies to I/O[11:8]) 00 : PLD disabled – Normal GPIO mode for I/O[11:8] 01 : PLD 2-to-1 mode – I/O[10] is a decode of I/O[9:8] as defined in RegPLDTable0B 10 : PLD 3-to-1 mode – I/O[11] is a decode of I/O[10:8] as defined in RegPLDTable2B 11 : PLD 3-to-2 mode – I/O[12:11] are decodes of I/O[10:8] as defined in RegPLDTable3B and RegPLDTable4B	
0x21	RegPLDModeA	0x00	7:6	Reserved. Must be set to 0 (default value)	
			5:4	PLDModeHighA (applies to I/O[7:4]) 00 : PLD disabled – Normal GPIO mode for I/O[7:4] 01 : PLD 2-to-1 mode – I/O[6] is a decode of I/O[5:4] as defined in RegPLDTable0A 10 : PLD 3-to-1 mode – I/O[7] is a decode of I/O[6:4] as defined in RegPLDTable1A 11 : Reserved	
			1:0	PLDModeLowA (applies to I/O[3:0]) 00 : PLD disabled – Normal GPIO mode for I/O[3:0] 01 : PLD 2-to-1 mode – I/O[2] is a decode of I/O[1:0] as defined in RegPLDTable0A 10 : PLD 3-to-1 mode – I/O[3] is a decode of I/O[2:0] as defined in RegPLDTable2A 11 : PLD 3-to-2 mode – I/O[4:3] are decodes of I/O[2:0] as defined in RegPLDTable3A and RegPLDTable4A	
0x22	RegPLDTable0B	0x00	7	Value to be output on I/O[14] when I/O[13:12] = 11	Applies only when PLDModeHighB is set to PLD 2-to-1 mode
			6	Value to be output on I/O[14] when I/O[13:12] = 10	
			5	Value to be output on I/O[14] when I/O[13:12] = 01	
			4	Value to be output on I/O[14] when I/O[13:12] = 00	
			3	Value to be output on I/O[10] when I/O[9:8] = 11	Applies only when PLDModeLowB is set to PLD 2-to-1 mode
			2	Value to be output on I/O[10] when I/O[9:8] = 10	
			1	Value to be output on I/O[10] when I/O[9:8] = 01	
			0	Value to be output on I/O[10] when I/O[9:8] = 00	
0x23	RegPLDTable0A	0x00	7	Value to be output on I/O[6] when I/O[5:4] = 11	Applies only when PLDModeHighA is set to PLD 2-to-1 mode
			6	Value to be output on I/O[6] when I/O[5:4] = 10	
			5	Value to be output on I/O[6] when I/O[5:4] = 01	
			4	Value to be output on I/O[6] when I/O[5:4] = 00	
			3	Value to be output on I/O[2] when I/O[1:0] = 11	Applies only when PLDModeLowA is set to PLD 2-to-1 mode
			2	Value to be output on I/O[2] when I/O[1:0] = 10	
			1	Value to be output on I/O[2] when I/O[1:0] = 01	
			0	Value to be output on I/O[2] when I/O[1:0] = 00	
0x24	RegPLDTable1B	0x00	7	Value to be output on I/O[15] when I/O[14:12] = 111	Applies only when PLDModeHighB is set to PLD 3-to-1 mode
			6	Value to be output on I/O[15] when I/O[14:12] = 110	
			5	Value to be output on I/O[15] when I/O[14:12] = 101	
			4	Value to be output on I/O[15] when I/O[14:12] = 100	
			3	Value to be output on I/O[15] when I/O[14:12] = 011	
			2	Value to be output on I/O[15] when I/O[14:12] = 010	
			1	Value to be output on I/O[15] when I/O[14:12] = 001	
			0	Value to be output on I/O[15] when I/O[14:12] = 000	
0x25	RegPLDTable1A	0x00	7	Value to be output on I/O[7] when I/O[6:4] = 111	Applies only when PLDModeHighA is set to PLD 3-to-1 mode
			6	Value to be output on I/O[7] when I/O[6:4] = 110	
			5	Value to be output on I/O[7] when I/O[6:4] = 101	
			4	Value to be output on I/O[7] when I/O[6:4] = 100	
			3	Value to be output on I/O[7] when I/O[6:4] = 011	
			2	Value to be output on I/O[7] when I/O[6:4] = 010	
			1	Value to be output on I/O[7] when I/O[6:4] = 001	
			0	Value to be output on I/O[7] when I/O[6:4] = 000	
0x26	RegPLDTable2B	0x00	7	Value to be output on I/O[11] when I/O[10:8] = 111	Applies only when PLDModeLowB is set to PLD 3-to-1 mode
			6	Value to be output on I/O[11] when I/O[10:8] = 110	
			5	Value to be output on I/O[11] when I/O[10:8] = 101	
			4	Value to be output on I/O[11] when I/O[10:8] = 100	
			3	Value to be output on I/O[11] when I/O[10:8] = 011	
			2	Value to be output on I/O[11] when I/O[10:8] = 010	
			1	Value to be output on I/O[11] when I/O[10:8] = 001	
			0	Value to be output on I/O[11] when I/O[10:8] = 000	
0x27		0x00	7	Value to be output on I/O[3] when I/O[2:0] = 111	Applies only when

WIRELESS & SENSING

Addr	Name	Default	Bits	Description	
	RegPLDTable2A		6	Value to be output on I/O[3] when I/O[2:0] = 110	PLDModelLowA is set to PLD 3-to-1 mode
			5	Value to be output on I/O[3] when I/O[2:0] = 101	
			4	Value to be output on I/O[3] when I/O[2:0] = 100	
			3	Value to be output on I/O[3] when I/O[2:0] = 011	
			2	Value to be output on I/O[3] when I/O[2:0] = 010	
			1	Value to be output on I/O[3] when I/O[2:0] = 001	
			0	Value to be output on I/O[3] when I/O[2:0] = 000	
0x28	RegPLDTable3B	0x00	7	Value to be output on I/O[11] when I/O[10:8] = 111	Applies only when PLDModelLowB is set to PLD 3-to-2 mode
			6	Value to be output on I/O[11] when I/O[10:8] = 110	
			5	Value to be output on I/O[11] when I/O[10:8] = 101	
			4	Value to be output on I/O[11] when I/O[10:8] = 100	
			3	Value to be output on I/O[11] when I/O[10:8] = 011	
			2	Value to be output on I/O[11] when I/O[10:8] = 010	
			1	Value to be output on I/O[11] when I/O[10:8] = 001	
0	Value to be output on I/O[11] when I/O[10:8] = 000				
0x29	RegPLDTable3A	0x00	7	Value to be output on I/O[3] when I/O[2:0] = 111	Applies only when PLDModelLowA is set to PLD 3-to-2 mode
			6	Value to be output on I/O[3] when I/O[2:0] = 110	
			5	Value to be output on I/O[3] when I/O[2:0] = 101	
			4	Value to be output on I/O[3] when I/O[2:0] = 100	
			3	Value to be output on I/O[3] when I/O[2:0] = 011	
			2	Value to be output on I/O[3] when I/O[2:0] = 010	
			1	Value to be output on I/O[3] when I/O[2:0] = 001	
0	Value to be output on I/O[3] when I/O[2:0] = 000				
0x2A	RegPLDTable4B	0x00	7	Value to be output on I/O[12] when I/O[10:8] = 111	Applies only when PLDModelLowB is set to PLD 3-to-2 mode
			6	Value to be output on I/O[12] when I/O[10:8] = 110	
			5	Value to be output on I/O[12] when I/O[10:8] = 101	
			4	Value to be output on I/O[12] when I/O[10:8] = 100	
			3	Value to be output on I/O[12] when I/O[10:8] = 011	
			2	Value to be output on I/O[12] when I/O[10:8] = 010	
			1	Value to be output on I/O[12] when I/O[10:8] = 001	
0	Value to be output on I/O[12] when I/O[10:8] = 000				
0x2B	RegPLDTable4A	0x00	7	Value to be output on I/O[4] when I/O[2:0] = 111	Applies only when PLDModelLowA is set to PLD 3-to-2 mode
			6	Value to be output on I/O[4] when I/O[2:0] = 110	
			5	Value to be output on I/O[4] when I/O[2:0] = 101	
			4	Value to be output on I/O[4] when I/O[2:0] = 100	
			3	Value to be output on I/O[4] when I/O[2:0] = 011	
			2	Value to be output on I/O[4] when I/O[2:0] = 010	
			1	Value to be output on I/O[4] when I/O[2:0] = 001	
0	Value to be output on I/O[4] when I/O[2:0] = 000				
0xAD	RegAdvanced	0x00	7:3	Reserved. Must be set to 0 (default value)	
			2	Autoclear NINT on RegData read (Cf. §4.6) 0: OFF.RegInterruptSource must be manually cleared directly or via RegEventStatus 1: ON.RegInterruptSource is automatically cleared when RegDataB or RegDataA is read	
			1:0	Reserved. Must be set to 0 (default value)	

Table 16 – SX1506 Configuration Registers Description

WIRELESS & SENSING

6 APPLICATION INFORMATION

6.1 Typical Application Circuit

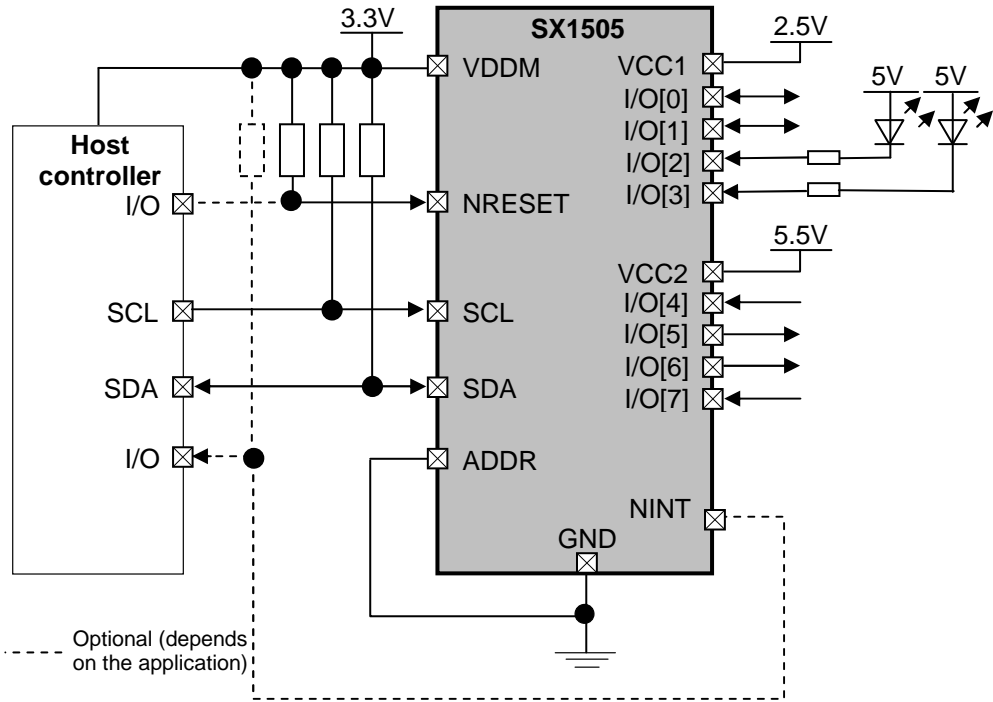
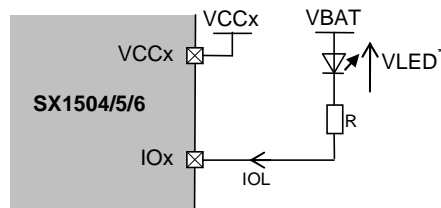

Figure 12 - Typical Application Schematic

6.2 Typical LED Operation

Typical LED operation is described below. The LED is usually connected to a high voltage (VBAT) to take advantage of the high sink current of the I/O and to accommodate high LED threshold voltages (VLED).



*LED colour/technology dependent

Figure 13 – Typical LED Operation

Important:

- ❖ VCCx must exceed VBAT-VLED (VCCx = VBAT is recommended) else the LED will never be completely OFF
- ❖ R must be calculated for IOL not to exceed its max spec (Cf. Table 5)

6.2.1 LED ON/OFF Control

	RegDir[x]	RegData[x]
LED ON	"0" (Output)	"0"
LED OFF		"1"

Table 17 – LED ON/OFF Control

WIRELESS & SENSING

6.2.2 LED Intensity Control

When the max IOL spec is not enough it is possible to drive simultaneously multiple I/Os connected together hence increasing the total sink capability.

Example: on an SX1505, by driving an LED with both IO[2] and IO[3] one can sink up to 24+24 =48mA.

Driving an LED with multiple I/Os can also be used to implement more intensity steps for the LED.

Example: with two I/Os capable of sinking each 24mA the LED can sink a total of 0mA (no I/O set to "0"), 24mA (one I/O set to "0") or 48mA (both I/Os set to "0") => 3 LED intensity steps (4 steps with 3 I/Os, 5 steps with 4 I/Os, etc)

6.3 Keypad Implementation

SX1504, SX1505, and SX1506 can be used to implement keypad applications up to 8x8 matrix (i.e. 64 keys)

Example: We want to implement a 4x4matrix keypad on SX1505

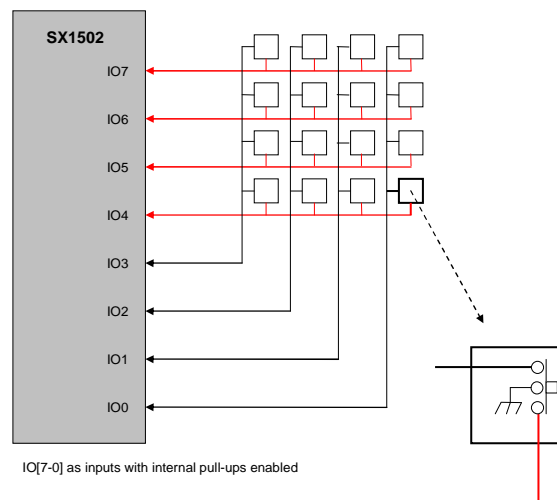

Figure 14 – 4x4 keypad connection to SX1505

1. Set all I/Os as inputs with internal pull-up (RegDir = 0xFF, RegPullUp = 0xFF)
2. Set NINT to be triggered on any IO's falling edge (RegInterruptMask = 0x00, RegSenseHigh = 0xAA, RegSenseLow = 0xAA)
3. When NINT goes low read RegData (or RegInterruptSource) to know the X:Y coordinates of the button which has been pressed.
4. Clear NINT (RegInterruptSource = 0xFF, can be done automatically on SX1506 depending on RegAdvanced setting)
5. Restart from point 3

6.4 Level Shifter Implementation Hints

Because of their I/O banks with independent supply voltages between 2.5V and 5.5V, the SX1505 and SX1506 can be used to perform level shifting of signals from one I/O bank to another (uC reads I/O from one I/O bank and sends it back to the other I/O bank)

This can save significant BOM cost in a final application where only a few slow signals need to be level-shifted.

WIRELESS & SENSING

7 PACKAGING INFORMATION

7.1 QFN-UT 20-pin Outline Drawing

QFN-UT 20-pin, 3 x 3 mm, 0.4 mm pitch

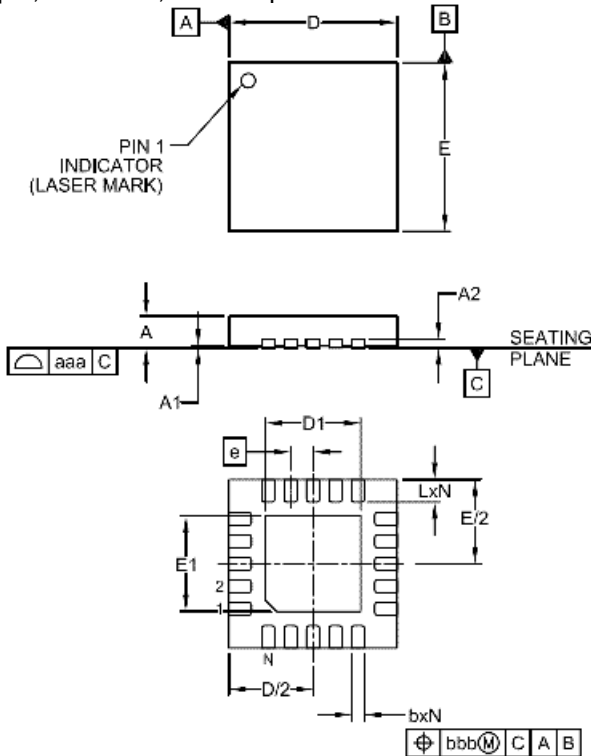

DIM	INCHES			MILLIMETERS		
	MIN	NOM	MAX	MIN	NOM	MAX
A	.020	-	.024	0.50	-	0.60
A1	.000	-	.002	0.00	-	0.05
A2	(.006)			(0.152)		
b	.006	.008	.010	0.15	0.20	0.25
D	.114	.118	.122	2.90	3.00	3.10
D1	.061	.067	.071	1.55	1.70	1.80
E	.114	.118	.122	2.90	3.00	3.10
E1	.061	.067	.071	1.55	1.70	1.80
e	.018 BSC			0.40 BSC		
L	.012	.016	.020	0.30	0.40	0.50
N	20			20		
aaa	.003			0.08		
bbb	.004			0.10		

NOTES:

1. CONTROLLING DIMENSIONS ARE IN MILLIMETERS (ANGLES IN DEGREES).
2. COPLANARITY APPLIES TO THE EXPOSED PAD AS WELL AS THE TERMINALS.
3. DAP IS 1.90 x 1.90mm.

Figure 15 - Packaging Information – QFN-UT 20-pin Outline Drawing

7.2 QFN-UT 20-pin Land Pattern

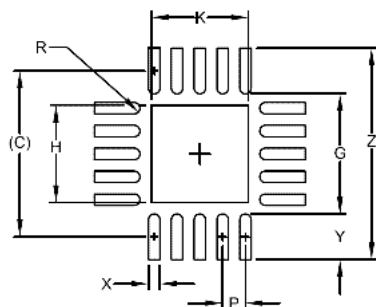

DIM	DIMENSIONS	
	INCHES	MILLIMETERS
C	(.114)	(2.90)
G	.083	2.10
H	.067	1.70
K	.067	1.70
P	.016	0.40
R	.004	0.10
X	.008	0.20
Y	.031	0.80
Z	.146	3.70

NOTES:

1. CONTROLLING DIMENSIONS ARE IN MILLIMETERS (ANGLES IN DEGREES).
2. THIS LAND PATTERN IS FOR REFERENCE PURPOSES ONLY. CONSULT YOUR MANUFACTURING GROUP TO ENSURE YOUR COMPANY'S MANUFACTURING GUIDELINES ARE MET.
3. THERMAL VIAS IN THE LAND PATTERN OF THE EXPOSED PAD SHALL BE CONNECTED TO A SYSTEM GROUND PLANE. FAILURE TO DO SO MAY COMPROMISE THE THERMAL AND/OR FUNCTIONAL PERFORMANCE OF THE DEVICE.

Figure 16 - Packaging Information – QFN-UT 20-pin Land Pattern

WIRELESS & SENSING

7.3 QFN-UT 28-pin Outline Drawing

QFN-UT 28-pin, 4 x 4 mm, 0.4 mm pitch

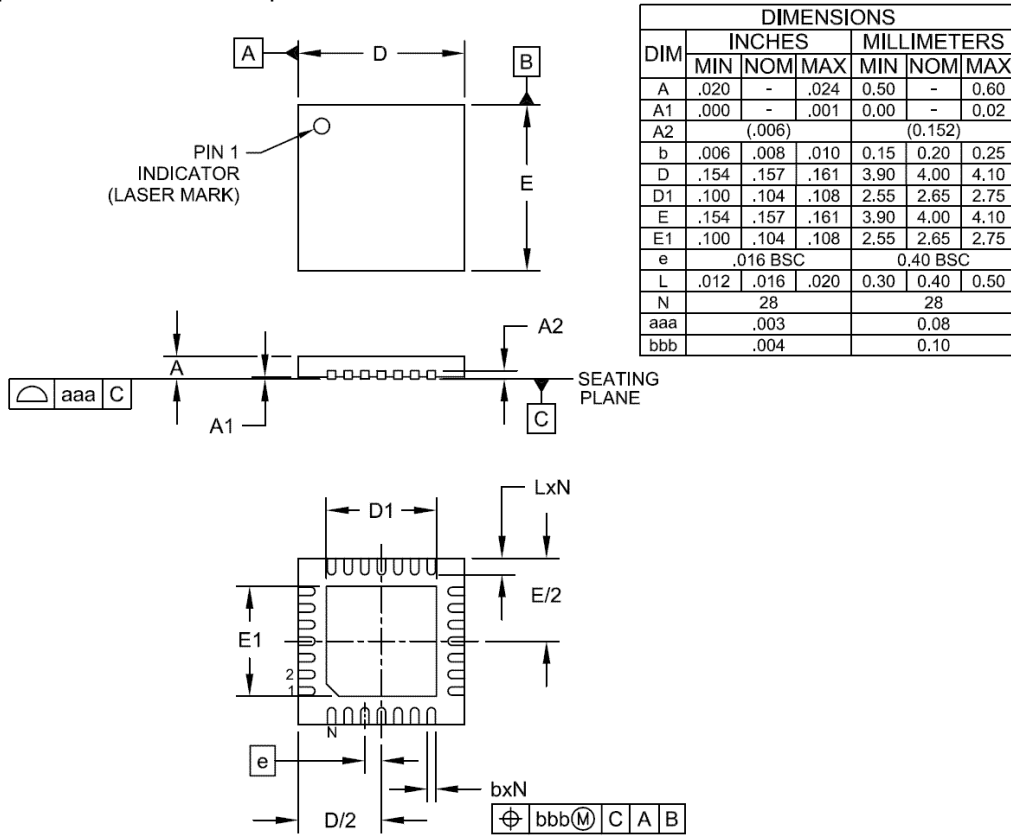

NOTES:

1. CONTROLLING DIMENSIONS ARE IN MILLIMETERS (ANGLES IN DEGREES).
2. COPLANARITY APPLIES TO THE EXPOSED PAD AS WELL AS THE TERMINALS.

Figure 17 - Packaging Information – QFN-UT 28-pin Outline Drawing

7.4 QFN-UT 28-pin Land Pattern

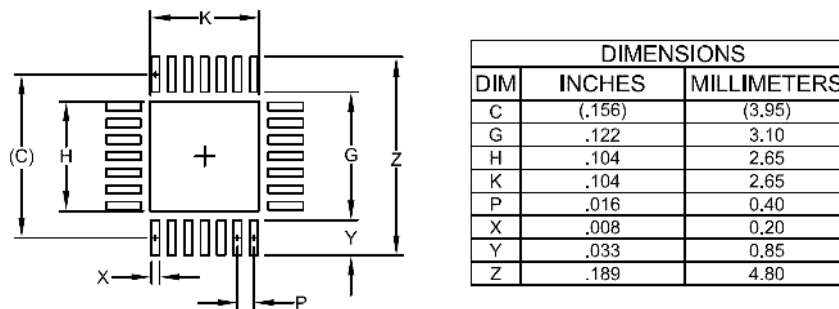

NOTES:

1. CONTROLLING DIMENSIONS ARE IN MILLIMETERS (ANGLES IN DEGREES).
2. THIS LAND PATTERN IS FOR REFERENCE PURPOSES ONLY. CONSULT YOUR MANUFACTURING GROUP TO ENSURE YOUR COMPANY'S MANUFACTURING GUIDELINES ARE MET.
3. THERMAL VIAS IN THE LAND PATTERN OF THE EXPOSED PAD SHALL BE CONNECTED TO A SYSTEM GROUND PLANE. FAILURE TO DO SO MAY COMPROMISE THE THERMAL AND/OR FUNCTIONAL PERFORMANCE OF THE DEVICE.
4. SQUARE PACKAGE-DIMENSIONS APPLY IN BOTH X AND Y DIRECTIONS.

Figure 18 - Packaging Information – QFN-UT 28-pin Land Pattern

WIRELESS & SENSING

8 SOLDERING PROFILE

The soldering reflow profile for the SX1504, SX1505 and SX1506 is described in the standard IPC/JEDEC J-STD-020C. For detailed information please go to <http://www.jedec.org/download/search/jstd020c.pdf>

Profile Feature	Sn-Pb Eutectic Assembly	Pb-Free Assembly
Average Ramp-Up Rate (T _{s_max} to T _p)	3 °C/second max.	3° C/second max.
Preheat		
- Temperature Min (T _{s_min})	100 °C	150 °C
- Temperature Max (T _{s_max})	150 °C	200 °C
- Time (t _{s_min} to t _{s_max})	60-120 seconds	60-180 seconds
Time maintained above:		
- Temperature (T _L)	183 °C	217 °C
- Time (t _L)	60-150 seconds	60-150 seconds
Peak/Classification Temperature (T _p)	See Table 4.1	See Table 4.2
Time within 5 °C of actual Peak Temperature (t _p)	10-30 seconds	20-40 seconds
Ramp-Down Rate	6 °C/second max.	6 °C/second max.
Time 25 °C to Peak Temperature	6 minutes max.	8 minutes max.

Note 1: All temperatures refer to topside of the package, measured on the package body surface.

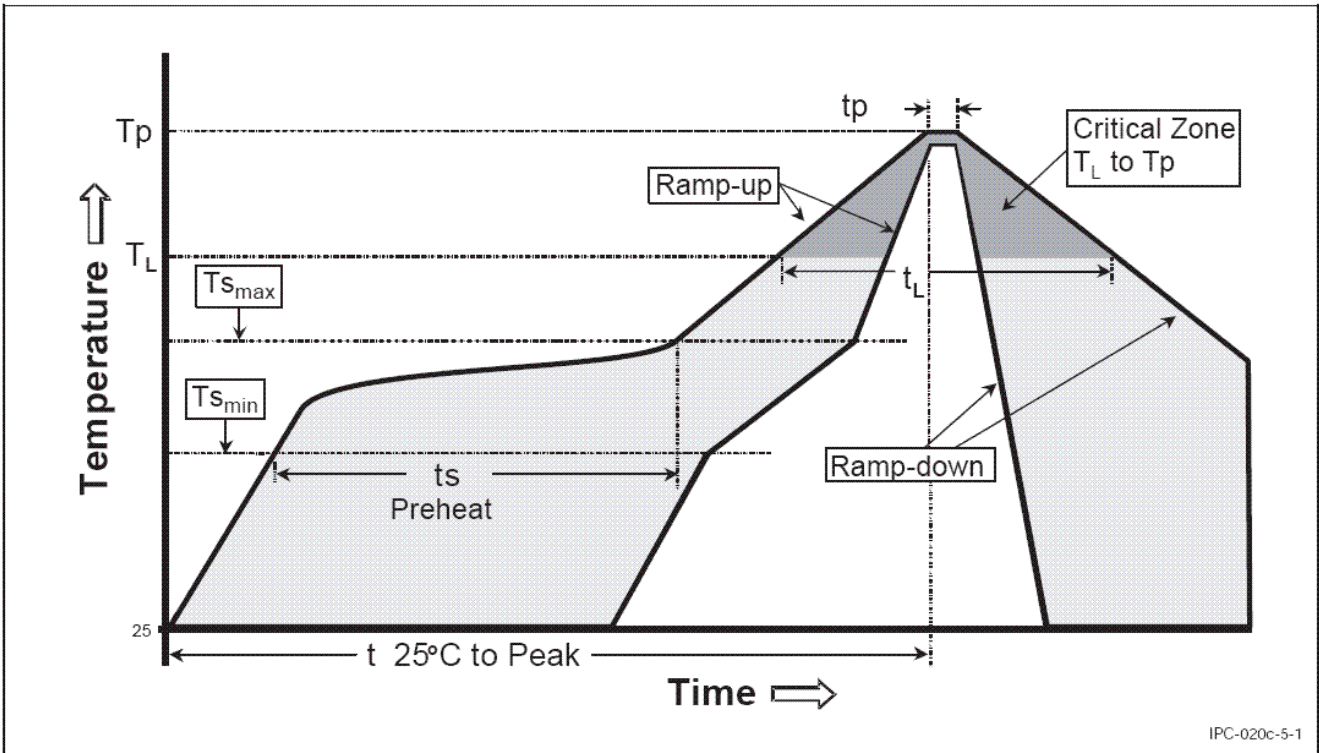

Figure 19 - Classification Reflow Profile (IPC/JEDEC J-STD-020C)

WIRELESS & SENSING

© Semtech 2012

All rights reserved. Reproduction in whole or in part is prohibited without the prior written consent of the copyright owner. The information presented in this document does not form part of any quotation or contract, is believed to be accurate and reliable and may be changed without notice. No liability will be accepted by the publisher for any consequence of its use. Publication thereof does not convey nor imply any license under patent or other industrial or intellectual property rights. Semtech assumes no responsibility or liability whatsoever for any failure or unexpected operation resulting from misuse, neglect improper installation, repair or improper handling or unusual physical or electrical stress including, but not limited to, exposure to parameters beyond the specified maximum ratings or operation outside the specified range.

SEMTECH PRODUCTS ARE NOT DESIGNED, INTENDED, AUTHORIZED OR WARRANTED TO BE SUITABLE FOR USE IN LIFE-SUPPORT APPLICATIONS, DEVICES OR SYSTEMS OR OTHER CRITICAL APPLICATIONS. INCLUSION OF SEMTECH PRODUCTS IN SUCH APPLICATIONS IS UNDERSTOOD TO BE UNDERTAKEN SOLELY AT THE CUSTOMER'S OWN RISK. Should a customer purchase or use Semtech products for any such unauthorized application, the customer shall indemnify and hold Semtech and its officers, employees, subsidiaries, affiliates, and distributors harmless against all claims, costs damages and attorney fees which could arise.

Notice: All referenced brands, product names, service names and trademarks are the property of their respective owners.

Contact Information

Taiwan	Tel: 886-2-2748-3380 Fax: 886-2-2748-3390	Switzerland	Tel: 41-32-729-4000 Fax: 41-32-729-4001
Korea	Tel: 82-2-527-4377 Fax: 82-2-527-4376	United Kingdom	Tel: 44-1794-527-600 Fax: 44-1794-527-601
Shanghai	Tel: 86-21-6391-0830 Fax: 86-21-6391-0831	France	Tel: 33-(0)169-28-22-00 Fax: 33-(0)169-28-12-98
Japan	Tel: 81-3-6408-0950 Fax: 81-3-6408-0951	Germany	Tel: 49-(0)8161-140-123 Fax: 49-(0)8161-140-124

Semtech International AG is a wholly-owned subsidiary of Semtech Corporation, which has its headquarters in the U.S.A