

THIS DRAWING IS UNPUBLISHED. RELEASED FOR PUBLICATION
 © COPYRIGHT - By - ALL RIGHTS RESERVED.

LOC		DIST		REVISIONS			
P	LTR	DESCRIPTION	DATE	DWN	APVD		
DF	X0	H	REVISED	18OCT12	PY	DW	

PART	MATERIAL	FINISH
INNER FURRULE SHELL	STAINLESS STEEL PER ASTM A484 & A582 TYPE 303	PASSIVATE PER QQ-P-35
COUPLING NUT		
DIELECTRIC	PTFE PER ASTM D 1457	-
SEAL	SILICONE RUBBER PER ZZ-R-765	-
RETAINING RING	BeCu PER ASTM B 194 ALLOY 172 CONDITION H	-
FERRULE	COPPER OR BRASS ALLOY, ROCKWELL F65 MAX	SEE TABLE
CONTACT	BRASS PER ASTM B16	GOLD PLATE PER MIL-DTL-45204

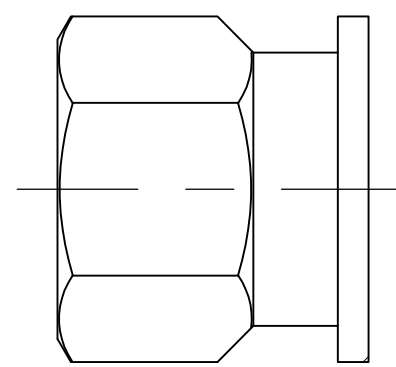

COUPLING NUT FOR 225532-1, -3, -4, -9, & -10

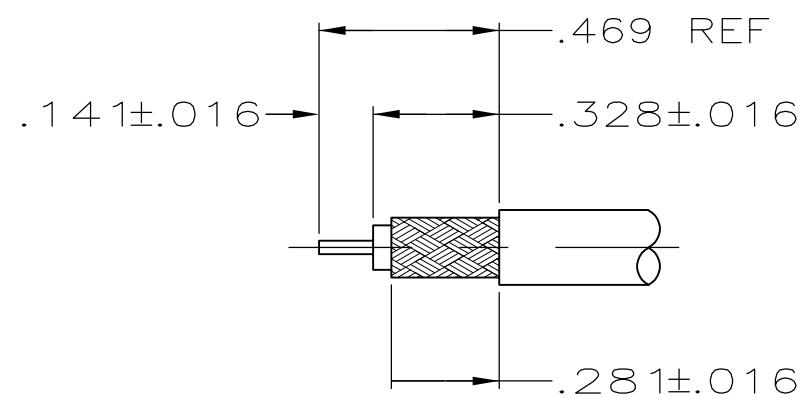
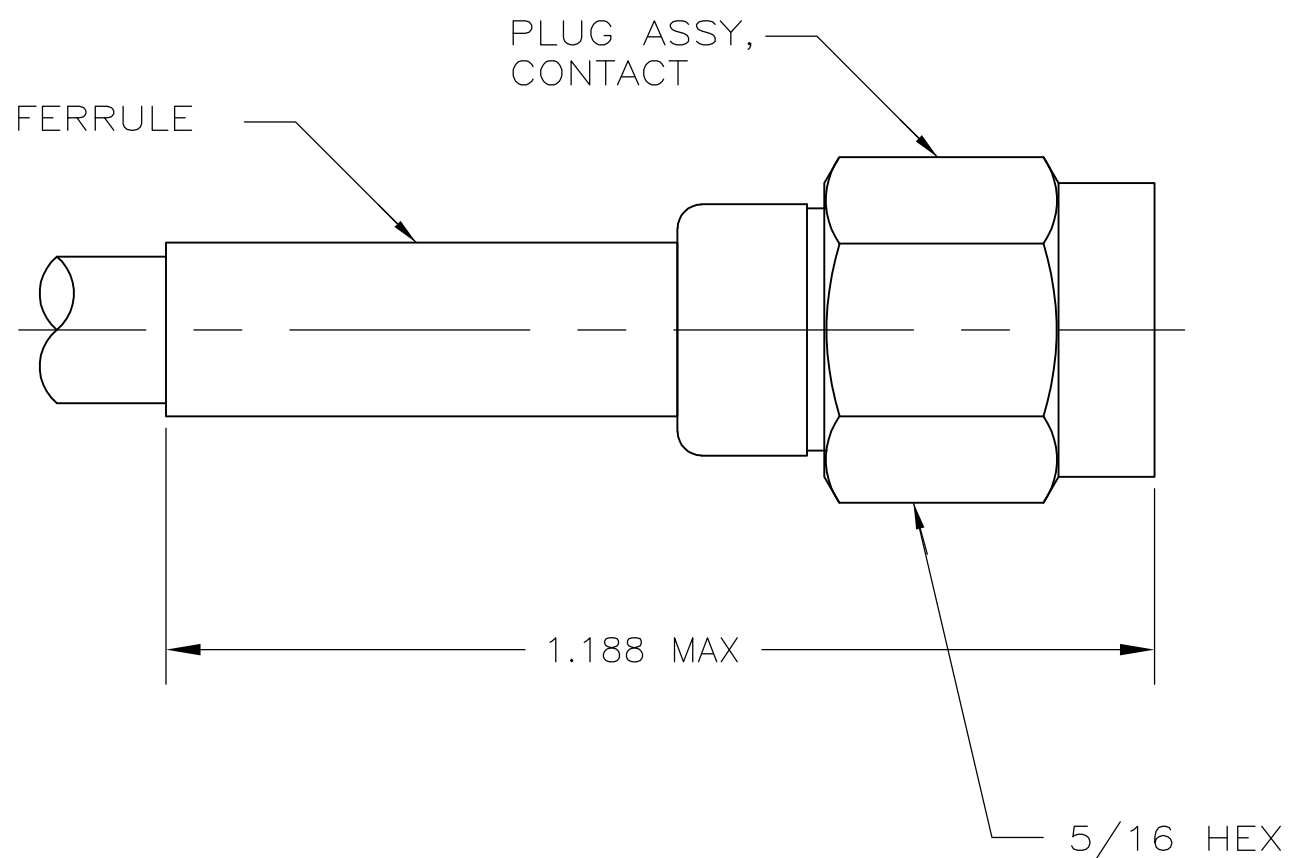

RECOMMENDED STRIP LENGTH
SCALE: 2:1

TIN PLATE PER ASTM B545	∅.115	∅.0680	∅.024	WITHOUT	RG-179B & 187A	-	5-225532-8
TIN PLATE PER ASTM B545	∅.115	∅.0650	∅.024	WITHOUT	RG-174, 188 & 316	-	1-225532-5
TIN PLATE PER ASTM B545	∅.230	∅.1210	∅.042	WITHOUT	RG-142, 142A & 142B	-	1-225532-4
SILVER PLATE PER QQ-S-365	∅.130	∅.0650	∅.024	WITHOUT	DBL BRAID RG-188 & 316	-	1-225532-1
TIN LEAD PLATE PER ASTM B545	∅.230	∅.1210	∅.042	WITH	RG-55A & 223	M39012/55B3023	1-225532-0
TIN LEAD PLATE PER ASTM B545	∅.207	∅.1210	∅.042	WITH	RG-141, 141A & 303	M39012/55B3024	225532-9
TIN LEAD PLATE PER ASTM B545	∅.115	∅.0680	∅.024	WITHOUT	RG-179B & 187A	-	225532-8
TIN LEAD PLATE PER ASTM B545	∅.115	∅.0650	∅.024	WITH	RG-174, 188 & 316	M39012/55B3019	225532-4
TIN LEAD PLATE PER ASTM B545	∅.230	∅.1210	∅.042	WITH	RG-142, 142A & 142B	M39012/55B3022	225532-3
TIN LEAD PLATE PER ASTM B545	∅.207	∅.1210	∅.042	WITH	RG-58A & 58C	M39012/55B3021	225532-1
FERRULE PLATING	FERRULE	HOUSING	CONTACT	SAFETY WIRE HOLES	CABLE SIZE	MILITARY P/N	PART NUMBER
	CABLE ENTRY DIAMETER						

THIS DRAWING IS A CONTROLLED DOCUMENT.

DWN	P. YEAGER	01MAR06
CHK	F. BLASICK	01MAR06
APVD	F. BLASICK	01MAR06

TE Connectivity

NAME: PLUG ASSEMBLY SERIES SMA

PRODUCT SPEC: 108-12027

APPLICATION SPEC: 408-2322

WEIGHT: .134 OZ

SCALE: 5:1 SHEET: 1 of 1 REV: H

CUSTOMER DRAWING