

LSI/CSI

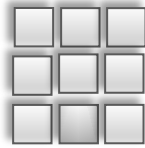

=

LS9200

LSI Computer Systems, Inc. 1235 Walt Whitman Rd, Melville, NY 11747 (631)271-0400, Fax: (631)271-0404

September 2022

DIMMABLE LED DRIVER

FEATURES:

- μ A range to 200mA regulated output drive
- Built-in chromatic shift free PWM dimming
- 0% to 100% PWM duty cycle regulation
- Supply voltage from 5V dc to rectified 120VAC/240VAC
- Overheat shutdown of output with hysteresis
- Qualifies for automotive temperature range
- Available in EP-SOP-8

APPLICATIONS:

- AC Light fixtures including ceiling light
- LED light bulb
- High intensity LED outdoors bulb
- Dimmable table lamp and light bar
- Instrumentation lighting
- Automotive dashboard and cabin lighting

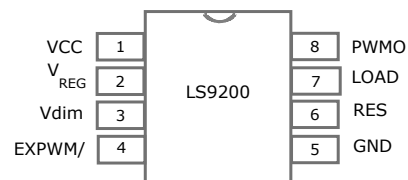

Fig 1. EP-SOP-8

GENERAL DESCRIPTION:

LS9200 is a monolithic CMOS device for driving and dimming LED networks. The regulated constant current is maintained with an external sense resistor forming part of a feedback loop. The maximum LED load current is set by the sense resistor whose duty cycle can be modulated with a built in PWM circuit. The Pulse Width modulated duty cycle results in chromatic shift-free dimming over the entire range of 0% to 100% due to the regulated constant current. There are two different ways to vary the PWM duty cycle, one with an analog voltage applied at the Vdim input and the other with an external PWM signal applied at the Vdim input. The input EXPWM/ selects one or the other PWM operational modes.

To protect the system from thermal runaway, shutdown of the driver output is invoked when the device temperature exceeds 120°C. The output recovers from shut down when the temperature cools down by around 15°C from the shutdown threshold.

Power supply for LS9200 can be provided from any voltage source from 5V DC to rectified 240VAC or higher with a current limiting series resistor. The internal supply voltage in all cases is regulated at 5V.

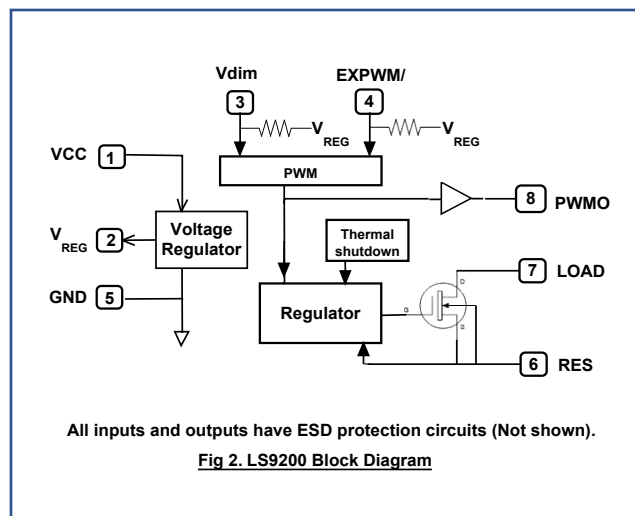

INPUTS/OUTPUTS:

VCC (pin 1). Power supply positive terminal. DC voltage supply can be provided from a very wide range of levels from 5VDC to rectified 240VAC. Supply voltages ranging between 5V and 10V can be directly applied to VCC pin. For supply voltages exceeding 10V a current limiting series resistor must be used between the supply and VCC to set the current between 550uA and 650uA. The resistor value is estimated as follows:
 $R = (V_{\text{supply}} - 10V) / 600\mu A$

V_{REG} (pin 2). The regulated internal 5V supply is brought out on pin 2. A 0.5uF or larger filter capacitor should be connected from pin 2 to ground.

Vdim (pin 3). Vdim input controls the LOAD output duty cycle and can operate in one of two ways selected by the EXPWM/ input. When EXPWM/ input is high, an analog voltage applied to pin 3 controls the load output duty cycle. Duty cycle is adjustable from 0% to 100% by varying the voltage between 0.5V and 3.2V. The variable voltage may be generated by using a potentiometer connected between VDD and GND. The duty cycle percentage can be estimated as follows:
 $[(V_{\text{dim}} - 0.5) / 2.7] \times 100$

When EXPWM/ input is low, Vdim input operates with an external PWM signal. In this mode dimming operation of several LS9200 devices can be synchronized with a single PWM signal produced by one device in the group.

EXPWM/ (pin 4). A low at the EXPWM/ input selects the mode in which an external PWM signal is applied to the Vdim input for LOAD output duty cycle control. A high at the EXPWM/ input selects the mode wherein an analog voltage at the Vdim input controls the LOAD output duty cycle as per fig 4.

GND (pin 5). Power supply ground, to be connected to the power supply negative terminal.

RES (pin 6). Current regulation resistor input. The LED maximum load current is set by a resistor connected between RES and GND as shown in fig 3A and 3B.

LOAD (pin 7). Current sink output for driving the negative terminal of the LED bank. The absolute maximum power dissipation of the driver output is 4W which decreases as the junction temperature increases. Up to 1.5W device dissipation thermal shutdown can be avoided without the use of any heatsink. For dissipations > 1.5W proper heat sink must be added to the PCB making direct contact with the exposed pad underneath the IC package. The maximum dissipation in watts can be estimate by:

$P_{\text{max}} = (120 - T_c) / 11$ where, T_c is the case temperature.

PWMO (pin 8). The internal PWM signal which controls the LOAD duty cycle is buffered out at this pin. This signal can be used by multiple LS9200 devices for synchronized dimming control.

ABSOLUTE MAXIMUM RATINGS:

(All voltages are referenced to GND; $T_A = +27^\circ\text{C}$ unless otherwise specified)

Supply voltage, VCC.....	12V
Supply current, ICC.....	1mA
Output voltage, V _{LOAD}	80V
Power dissipation, (V _{LOAD} - V _{RES}) x I _{LOAD}	5W
Input voltages (all inputs).....	-0.3V min, V _{REG} + 0.3V max
Operating temperature.....	-40°C to +125°C
Storage temperature.....	-65°C to +150°C

The information included herein is believed to be accurate and reliable. However, LSI Computer Systems, Inc. assumes no responsibilities for inaccuracies, or for any infringements of patent rights of others which may result from its use

WARNING: In all applications incorporating LS9200, proper and adequate heat dissipation measures must be taken to keep the junction temperature equal to or below 125°C. LSI Computer Systems, Inc. will not be held responsible for any damage caused by improper use of this part.

ELECTRICAL AND TRANSIENT CHARACTERISTICS; unless specified otherwise VCC = 6V, T_A = -40° to +85° C

Parameter	Symbol	Min	Typ	Max	Unit	Condition
Supply voltage	VCC	5	-	10	V	For Vsupply >10V, supply current must be limited to 900uA max with external resistor in series with VCC
Supply current	I _{CC}	-	600	900	uA	Current limited with external series resistor
Regulated voltage	V _{REG}	-	4.6	-	V	@ I _{VREG} = 200uA
Output sink current	I _{LOAD}	0.005	-	200	mA	@ V _{LOAD} ≥ 7V; current adjusted with sense resistor at pin-6
Output voltage	V _{LOAD}	5.0	-	75.0	V	LOAD output dissipation limited to 4W
EXPWM/ input hi	V _{EPWH}	-	2.8	3.4	V	
EXPWM/ input lo	V _{EPWL}	1.2	1.8	-	V	
V _{dim} input , thresholds	V _{dimlo}	-	0.5	-	V	LOAD output duty cycle = 0%
	V _{dimhi}	-	3.2	-	V	LOAD output duty cycle = 100%
EXPWM/ V _{DIM} input high current	I _{EPDMH}	-	6	10	uA	Vin = 4.5V
EXPWM/ V _{DIM} input low current	I _{EPDML}	-	-8	-14.0	uA	Vin = 0.5V
PWM frequency	f _{PWM}	15	22	30	KHz	
PWMO output sink	I _{PSNK}	750	1400	-	uA	@V _O = 0.5V
PWMO output src	I _{PSRC}	-200	-300	-	uA	@V _O = VDD - 1V
PWMO rise time	t _{PR}	-	250	330	nS	@ 100pf load
PWMO fall time	T _{PF}	-	90	160	nS	@100pf load
LOAD output current regulation (See Note 1)		-	1.0	-	%	(ΔI _{LOAD} /ΔV _{LOAD}) x100, ΔV _{LOAD} =70V-10V, I _{LOAD} (nom)=25mA
		-	6.6	-	%	(ΔI _{LOAD} /ΔV _{LOAD}) x100, ΔV _{LOAD} =40V-10V, I _{LOAD} (nom)=120mA
		-	9.0	-	%	(ΔI _{LOAD} /ΔV _{LOAD}) x100, ΔV _{LOAD} =20V-10V, I _{LOAD} (nom)=200mA
LOAD output dissipation	P _{LOAD}	-	-	4.0	Watt	P _{LOAD} = (V _{LOAD} - V _{RES}) x I _{LOAD} , T _A ≤ 50°C
Thermal shutdown	T _{SHTDN}	-	120	-	°C	Thermal shutdown in temperature upswing
Shutdown recovery	T _{RCVR}	-	105	-	°C	Recovery from shutdown in temperature downswing
Thermal resistance	R _{θJC}	-	11	-	°C/W	Thermal resistance between junction and case

Note 1. For I_{LOAD} = 120mA and 200mA V_{LOAD} have been limited to 40V and 20V to limit P_{LOAD} to 4W.

Note 2. For P_{LOAD} > 1.5W, adequate heat sink must be used to prevent thermal shutdown. Maximum P_{LOAD} dissipation can be estimated by: P_{max} = (T_{SHTDN} - T_c)/R_{θJC}, where T_c = case temperature

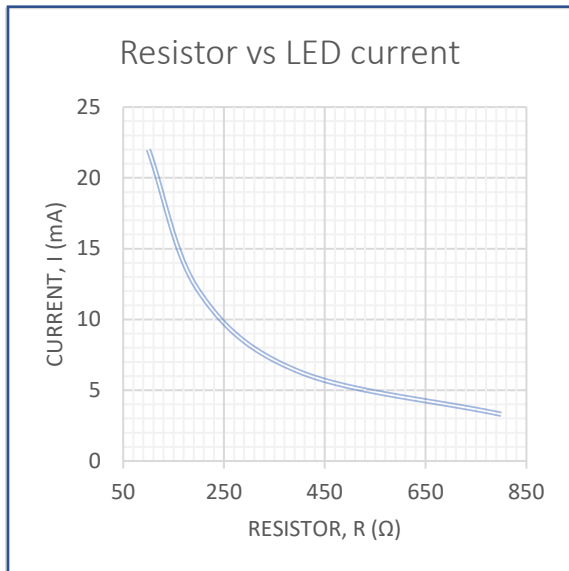

Fig 3A. Load current vs resistor (R_{RES}) at pin 6

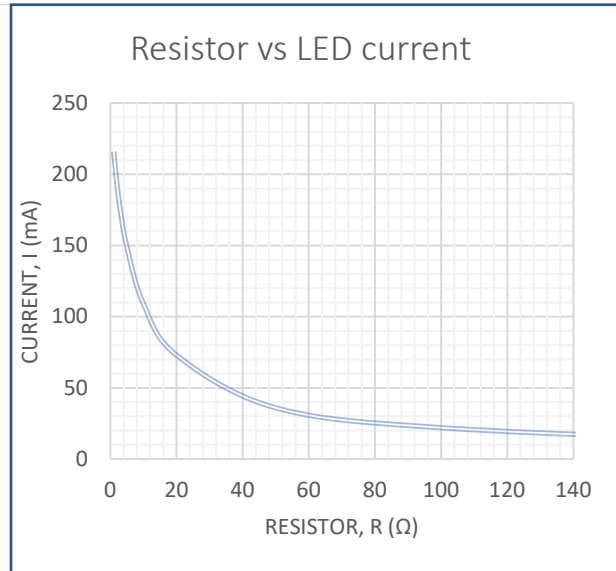

Fig 3B. Load current vs resistor (R_{RES}) at pin 6

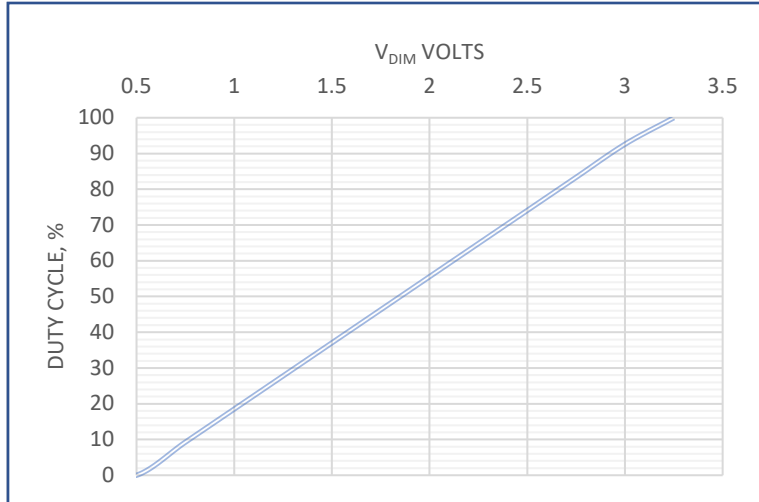
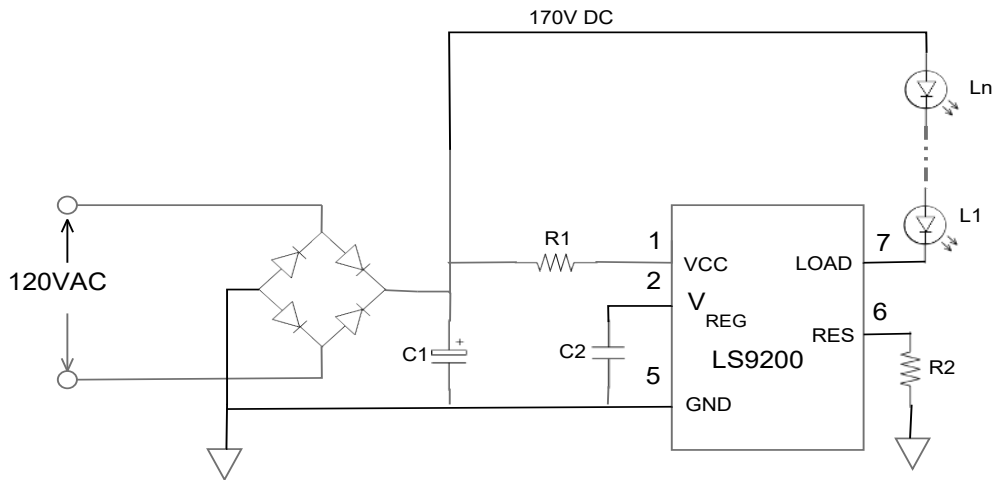

Fig 4. V_{DIM} voltage vs PWM duty cycle



Components for this design can be selected as follows:

Step 1. Select R1 for 170V (See pin 1 description on page 2): $(170V - 10V) / 600\mu A = 267K\Omega$.

Step 2. Select LED. Spec example: $I_F = 150mA$, $V_F = 3V$, flux = 60lm

Step 3. Select R2 for 150mA from fig 3B. $R2 = 5\Omega$

Step 4. Estimate maximum voltage allowed at pin 8 for $I_{LED} = 150mA$: $(V_{LOAD} - 150mA \times R2) \times 150mA \leq 4W$ (maximum dissipation)
 $V_{LOAD} \leq 4W/150mA + 150mA \times R2 = 26.7V + 0.75V = 27.45V$

Step 5. Estimate the number of LEDs in stack for the intended lumen: $n = 3000lm/60lm = 50$

Step 6. Verify that n number of LEDs have adequate drop for V_{LOAD} to be at $\leq 28.5V$.

$$V_{LOAD} = 170V - 50 \times 3 = 20V$$

Summary of components: $R1 = 267K\Omega$, 1/4W; $R2 = 5\Omega$, 1/4W; number of LEDs = 50, $C1 = 50\mu F$, 250V; $C2 = 0.5\mu f$, 12V

Fig 6. Design of a 3000lm, 23W outdoors flood light

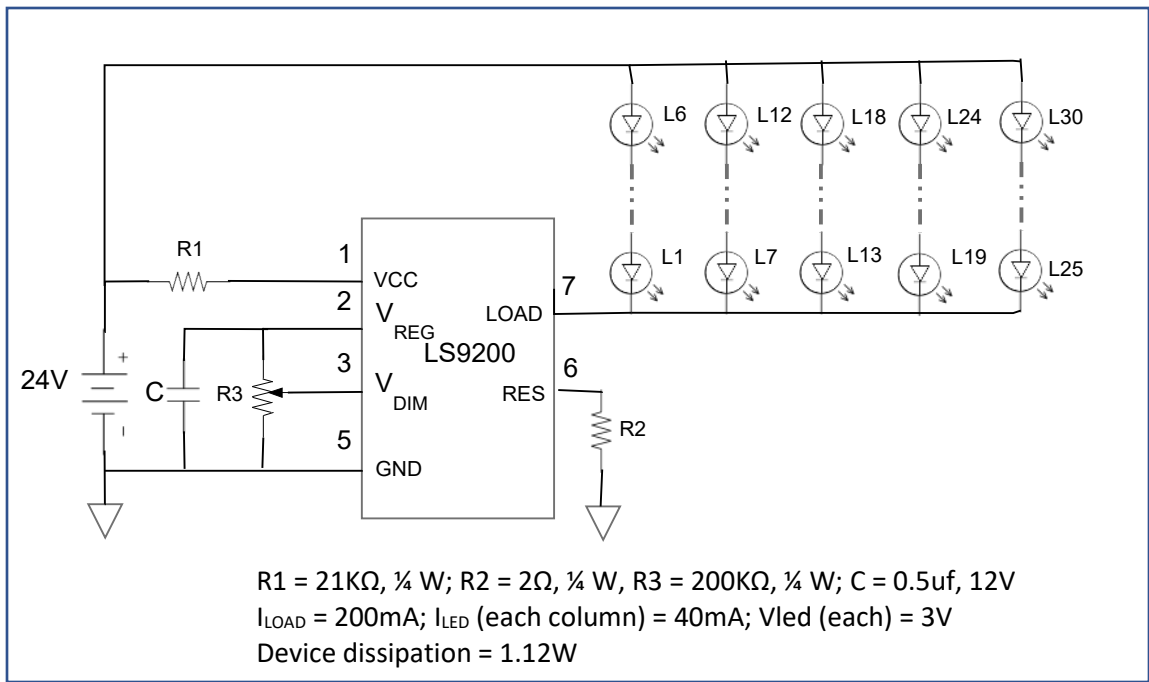

Fig 7. Instrumentation lighting with adjustable brightness

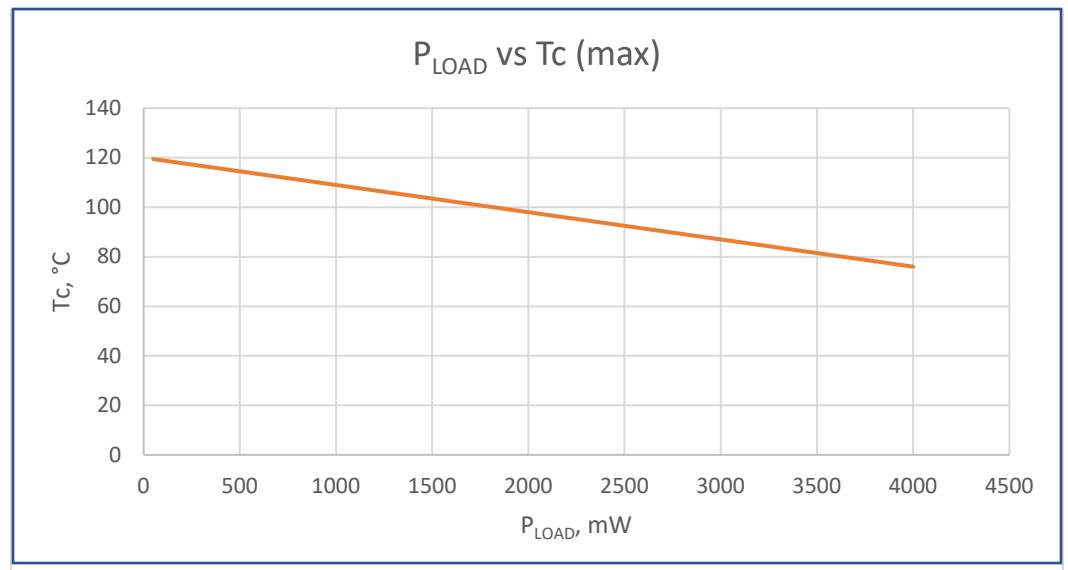
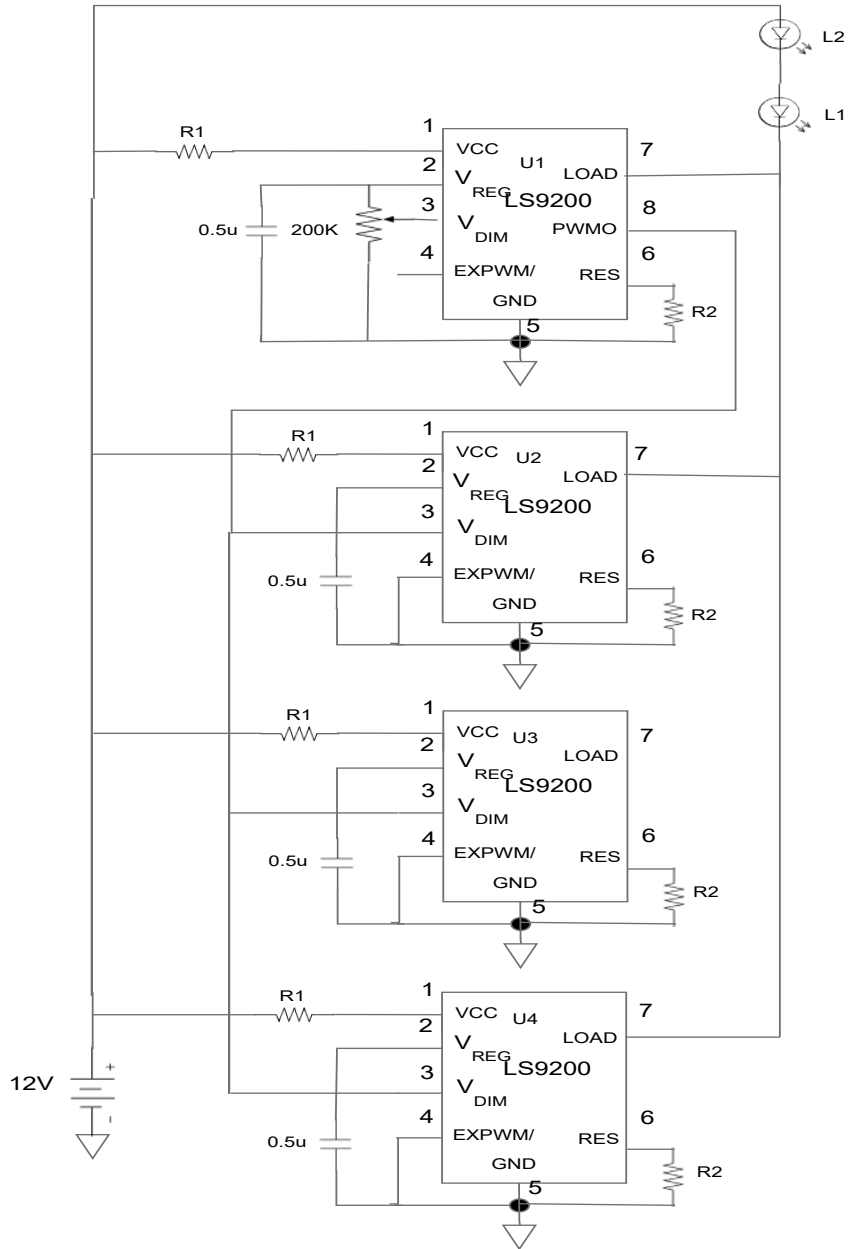

Fig 8. Load output dissipation vs maximum case temperature



R1 = 3.3K Ω 1/4W, R2 = 2 Ω 1/4W, L1 and L2 = (800mA, 440lm, 3V)
 Output load (each device) = 200mA, total = 800mA; Lumen (total max) = 880lm
 LED dissipation (each) = 2.4W; device dissipation (each) = 1.12W
 PWM duty-cycle of all devices are controlled synchronously by the 200K pot
 at U1 pin3

Warning. Proper heat sink must be used to prevent junction temperature from reaching 120°C and causing thermal shutdown.

Fig 9. Multi-device load sharing with synchronous PWM dimming

Package Outline: EP-SOP-8

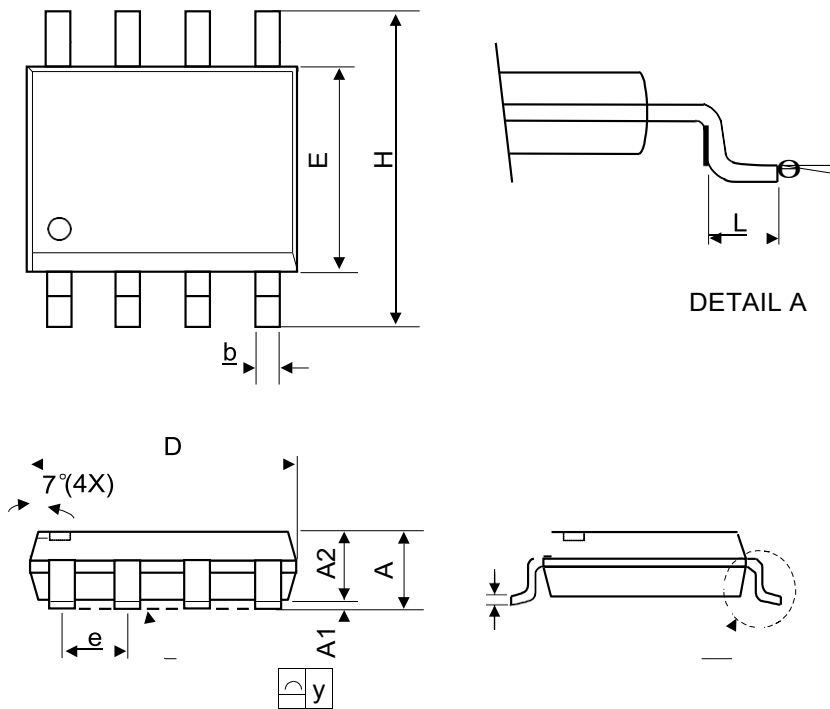

SYMBOL	MILLIMETER			INCHES		
	MIN	NOM	MAX	MIN	NOM	MAX
A	-	-	1.75	-	-	0.069
A1	0.1	-	0.25	0.04	-	0.1
A2	1.25	-	-	0.049	-	-
C	0.1	0.2	0.25	0.0075	0.008	0.01
D	4.7	4.9	5.1	0.185	0.193	0.2
E	3.7	3.9	4.1	0.146	0.154	0.161
H	5.8	6	6.2	0.228	0.236	0.244
L	0.4	-	1.27	0.015	-	0.05
b	0.31	0.41	0.51	0.012	0.016	0.02
e	1.27 BSC			0.050 BSC		
y	-	-	0.1	-	-	0.004
θ	0°	-	8°	0°	-	8°