

LOC		DIST		REVISIONS			
P	LTR	DESCRIPTION	DATE	DWN	APVD		
DS	-	0	RELEASED(FC00-0159-03)	10/NOV/03	MS	CS	
		A	REVISED(FC00-0038-04)	10/MAR/04	MS	CS	

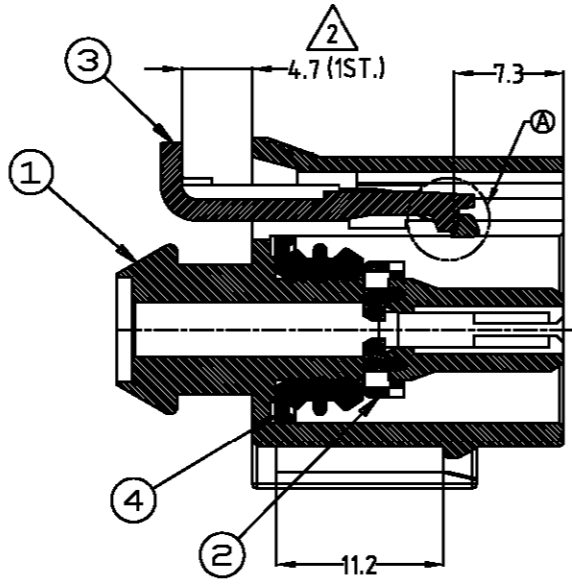

SECTION A-A
SCALE 2.000

- NOTES;
- GENERAL TOLERANCE IS ± 0.3
 - CONDITION OF DELIVERY :
DBL & CPA IN 1ST. LOCKING POSITION
 - APPLIED RECEPTACLE CONTACT P/N : TABLE 1.
 - APPLIED SINGLE WIRE SEAL P/N :
INSUL. $\phi 1.4 \sim 1.9$ mm : 0-963530-1(0.5-0.75 sqmm),
INSUL. $\phi 1.9 \sim 2.1$ mm : 0-964972-1(1.0 sqmm)
 - CAVITY PLUG SEAL P/N : 0-964972-1(1.0 sqmm)
 - APPLIED CLIP HSG P/N : TABLE 2

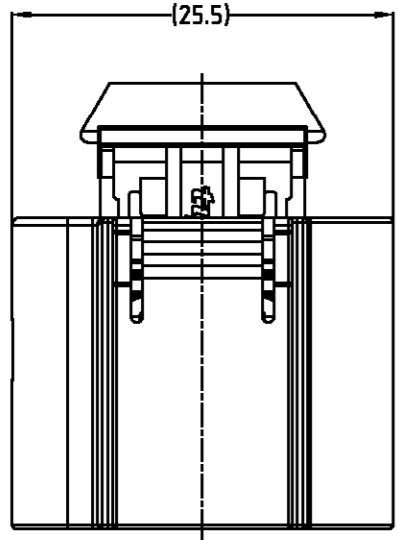
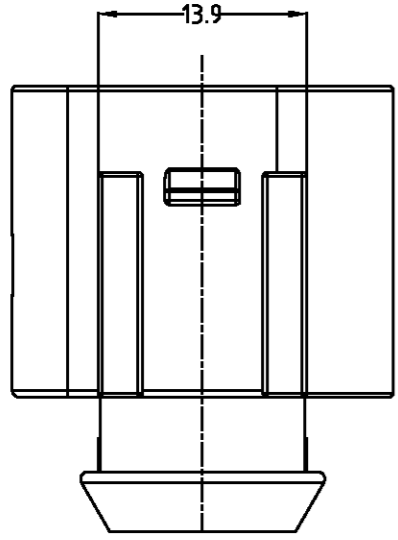
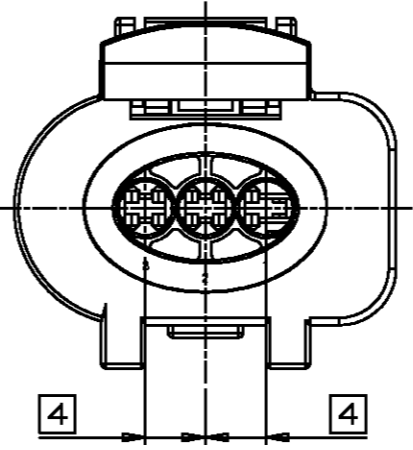
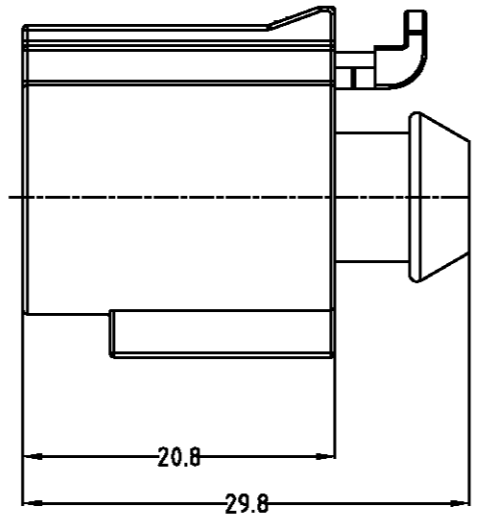
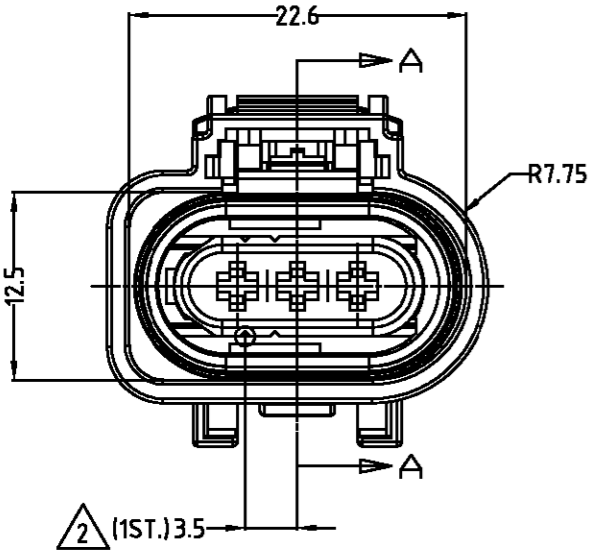
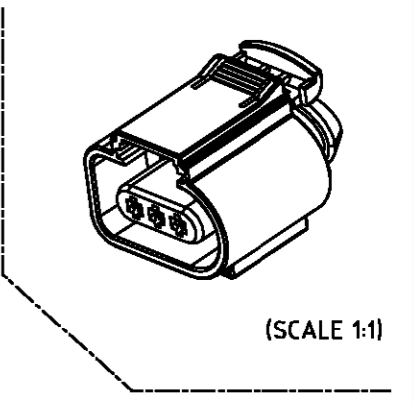

<TABLE 1>

TYPE	Part NO.	WIRE SIZE(mm ²)	FINISH
MICRO TIMER II	0-962876-1	0.5-1.0	CuSn4
	0-962876-3		CuSn4(GOLD)

NO	P/N	DESCRIPTION	MATERIAL	COLOR	Q'TY	ASS'Y P/N
④	0-936890-1	INNER SEAL	SILICONE	RED BROWN	1	0-936586-2
③	0-936589-5	CPA HSG	PBT GF15	YELLOW	-	1-936586-2
③	0-936589-1	CPA HSG	PBT GF15	WHITE	1	-
②	0-936588-6	DBL HSG	PBT GF15	WINE RED	1	1
①	0-936587-2	PLUG HSG	PA66 GF30	BLACK	1	1

<TABLE 2>

Part NO.	PANEL THICKNESS	PANEL HOLE SIZE
368269-1 (KEY HOLE)	0.7-1.6mm	
368260-1 (HOLE TYPE)		

THIS DRAWING IS A CONTROLLED DOCUMENT FOR TYCO ELECTRONICS CORPORATION. IT IS SUBJECT TO CHANGE AND THE CONTROLLING ENGINEERING ORGANIZATION SHOULD BE CONTACTED FOR THE LATEST REVISION.

DWN : MS HER
 CHK : BM JANG
 APVD : CS LEE
 PRODUCT SPEC
 APPLICATION SPEC
 WEIGHT

tyco AMP KOREA
Electronics Kyungsan Korea

NAME
PLUG ASSEMBLY FOR TPMS 3P

SIZE: A3 CAGE CODE: 00779 DRAWING NO: C-936586 RESTRICTED TO

SCALE 2/1 SHEET 1 OF 1 REV A