

REVISIONS				
P	LTR	DESCRIPTION	DATE	APVD
	N2	REV PER ECN-22-156403	03JUN2022	RK CSD

AMP WIRE RANGE	E13288 Listed	LR7189 Certified
16-14 AWG SOLID OR STRANDED	16-14 AWG SOLID OR STRANDED	16-14 AWG SOLID OR STRANDED

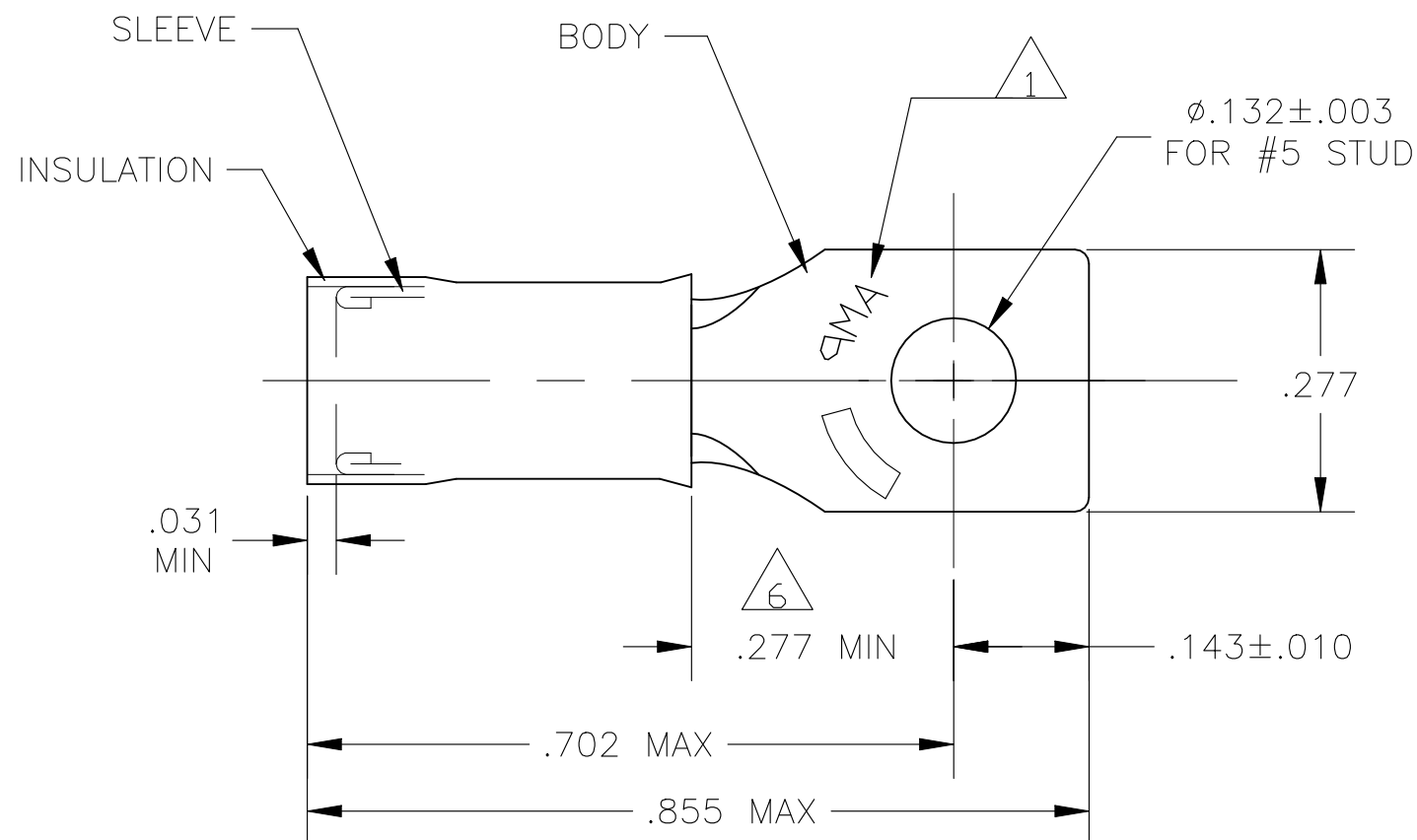

- 1 STAMP AMP 16-14* APPROX AS SHOWN
- 2 WIRE INSULATION DIA: .105-.150
- 3 TONGUE MATERIAL THK: .031±.002
- 4 BODY & SLEEVE: CU PER ASTM B152
INSULATION: NYLON PER ASTM D4066
- 5 BODY & SLEEVE: TIN PLATE .000100 MIN
EXT THK PER ASTM B545
INSULATION: COLOR - BLUE
- 6 APPLIES FROM EDGE OF METAL WIRE BARREL
TO CENTER OF STUD HOLE.
- 7 MEETS MS17143-11, CLASS 1
- 8 SUPERSEDED BY 2-327952-2

8	2-327952-5 ON TAPE & REEL	2-327952-6
8	500 LOOSE PIECE	2-327952-5
8	500 LOOSE PIECE	7 2-327952-2
8	--- LOOSE PIECE	327952
QTY	PACKAGE TYPE	PART NO

CUSTOMER SERVICE SYSTEMS		MAX RECOMMENDED OPERATING TEMPERATURE: 170°C MAX	THIS DRAWING IS A CONTROLLED DOCUMENT.		DWN JR RUTH 12JAN10	TE Connectivity				
FOR ADDITIONAL PRODUCT INFORMATION OR COPIES OF DRAWINGS AND TECHNICAL DOCUMENTS	PRODUCT INFORMATION CENTER 1-800-522-6752	VOLTAGE RATING: 300 V MAX	DIMENSIONS: INCHES	TOLERANCES UNLESS OTHERWISE SPECIFIED:	CHK T MICHELUTTI 13JAN10				NAME TERMINAL, RECTANGULAR TONGUE, PIDG WIRE SIZE: 16-14 AWG	
FOR APPLICATION TOOLING INFORMATION	TOOLING ASSISTANCE CENTER 1-800-722-1111	CIRCULAR MIL AREA: 1.04-2.62mm² [2,050-5,180] STRANDED OR SOLID		0 PLC ± - 1 PLC ± - 2 PLC ± - 3 PLC ± .008 4 PLC ± - ANGLES ± -	APVD T MICHELUTTI 13JAN10	PRODUCT SPEC	SIZE	CAGE CODE	DRAWING NO	RESTRICTED TO
FOR ORDER ENTRY	1-800-526-5142	THIS DRAWING IS A CONTROLLED DOCUMENT FOR AMP INCORPORATED. IT IS SUBJECT TO CHANGE AND THE CONTROLLING ENGINEERING ORGANIZATION SHOULD BE CONTACTED FOR THE LATEST REVISION.	MATERIAL -4	FINISH -5	---	APPLICATION SPEC	---	---	---	---
					CUSTOMER DRAWING		SCALE 5:1	SHEET 1 OF 1	REV N2	