

ISL62881C, ISL62881D

Single-Phase PWM Regulator for IMVP-6.5™ Mobile CPUs and GPUs

FN7596
Rev 0.00
March 8, 2010

The ISL62881C provides a complete solution for microprocessor and graphic processor core power supply with its integrated gate drive. Based on Intersil's Robust Ripple regulator (R3™) technology, the PWM modulator compared to traditional modulators, has faster transient settling time, variable switching frequency during load transients and has improved light load efficiency with its ability to automatically change switching frequency.

Fully compliant with IMVP6.5™, the ISL62881C is easily configurable as a CPU or graphics V_{CORE} controllers by offering: responds to DPRSLPVR signals by entering/exiting diode emulations mode; reports regulator output current via the IMON pin; senses current by using a discrete resistor or the inductor; over-temperature thermal compensation of DCR, using a single NTC thermistor; differential sensing to accurately monitor and adjust processor die voltage; minimizes body diode conduction loss in diode emulation mode with its adaptive body diode conduction time.

Need to aggressively reduce the output capacitor? The overshoot reduction function is user-selectable and can be disabled for those concerned about increased system thermal stress.

Maintaining all the ISL62881C functions, the ISL62881D offers VR_TT# function for thermal throttling control. It also offers the split LGATE function to further improve light load efficiency.

Features

- Precision Core Voltage Regulation
 - 0.5% System Accuracy Over-Temperature
 - Enhanced Load Line Accuracy
- Supports Multiple Current Sensing Methods
 - Lossless Inductor DCR Current Sensing
 - Precision Resistor Current Sensing
- Current Monitor
- Differential Remote Voltage Sensing
- Integrated Gate Driver
- Split LGATE Driver to Increase Light-Load Efficiency (For ISL62881D)
- Adaptive Body Diode Conduction Time Reduction
- User-selectable Overshoot Reduction Function
- Small Footprint 28 Ld 4x4 or 32 Ld 5x5 TQFN Package

Applications

- Notebook Core Voltage Regulator
- Notebook GPU Voltage Regulator

Related Literature

- See [AN1552](#) for Evaluation Board Application Note "ISL62881CCPUEVAL2Z User Guide"
- See [AN1553](#) for Evaluation Board Application Note "ISL62881CGPUEVAL2Z User Guide"

Load Line Regulation

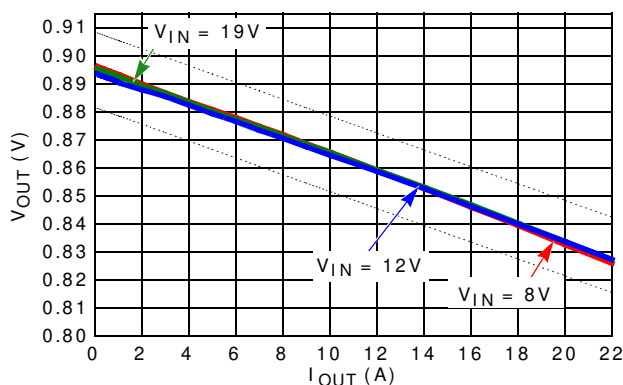

Ordering Information

PART NUMBER (Notes 1, 2, 3)	PART MARKING	TEMP. RANGE (°C)	PACKAGE (Pb-Free)	PKG. DWG. #
ISL62881CHRTZ	62881C HRTZ	-10 to +100	28 Ld 4x4 TQFN	L28.4x4
ISL62881CI RTZ	62881C I RTZ	-40 to +100	28 Ld 4x4 TQFN	L28.4x4
ISL62881DHRTZ	62881D HRTZ	-10 to +100	32 Ld 5x5 TQFN	L32.5x5E

NOTES:

- Add "-T" suffix for tape and reel. Please refer to [TB347](#) for details on reel specifications.
- These Intersil Pb-free plastic packaged products employ special Pb-free material sets, molding compounds/die attach materials, and 100% matte tin plate plus anneal (e3 termination finish, which is RoHS compliant and compatible with both SnPb and Pb-free soldering operations). Intersil Pb-free products are MSL classified at Pb-free peak reflow temperatures that meet or exceed the Pb-free requirements of IPC/JEDEC J STD-020.
- For Moisture Sensitivity Level (MSL), please see device information page for [ISL62881C](#), [ISL62881D](#). For more information on MSL please see techbrief [TB363](#).

Pin Configurations

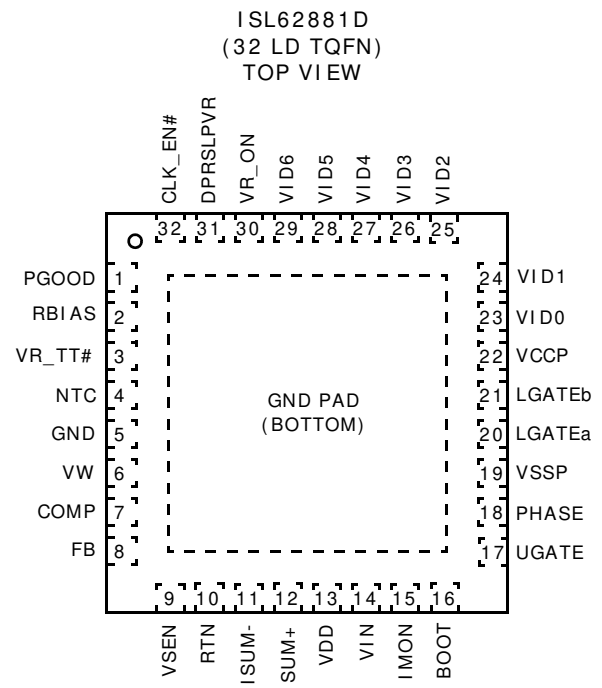
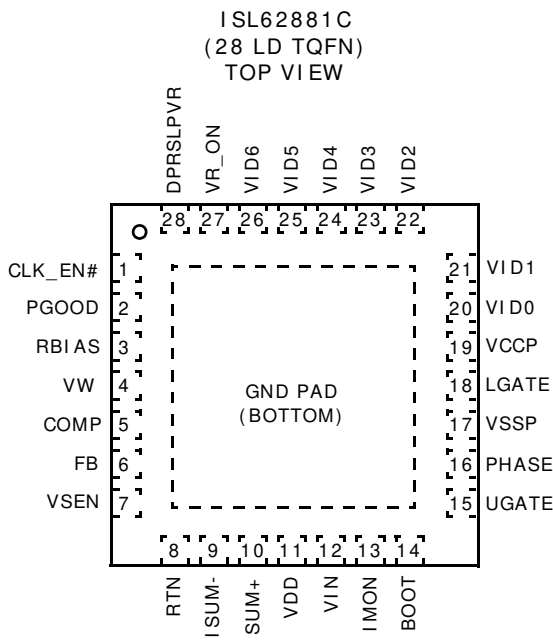

Pin Function Description

ISL62881C	ISL62881D	SYMBOL	DESCRIPTION
1	32	CLK_EN#	Open drain output to enable system PLL clock. It goes low 13 switching cycles after V_{CORE} is within 10% of V_{BOOT} .
2	1	PGOOD	Power-Good open-drain output indicating when the regulator is able to supply regulated voltage. Pull up externally with a 680Ω resistor to VCCP or 1.9kΩ to 3.3V.
3	2	RBIAS	A resistor to GND sets internal current reference. A 147kΩ resistor sets the controller for CPU core application and a 47kΩ resistor sets the controller for GPU core application.
-	3	VR_TT#	Thermal overload output indicator.
-	4	NTC	Thermistor input to VR_TT# circuit.
-	5	GND	Signal common of the IC. Unless otherwise stated, signals are referenced to the GND pin.

Pin Function Description (Continued)

ISL62881C	ISL62881D	SYMBOL	DESCRIPTION
4	6	VW	A resistor from this pin to COMP programs the switching frequency (8kΩ gives approximately 300kHz).
5	7	COMP	This pin is the output of the error amplifier. Also, a resistor across this pin and GND adjusts the overcurrent threshold.
6	8	FB	This pin is the inverting input of the error amplifier.
7	9	VSEN	Remote core voltage sense input. Connect to microprocessor die.
8	10	RTN	Remote voltage sensing return. Connect to ground at microprocessor die.
9, 10	11, 12	ISUM- and ISUM+	Droop current sense input.
11	13	VDD	5V bias power.
12	14	VIN	Power stage supply voltage, used for feed-forward.
13	15	IMON	An analog output. IMON outputs a current proportional to the regulator output current.
14	16	BOOT	Connect an MLCC capacitor across the BOOT and the PHASE pin. The boot capacitor is charged through an internal boot diode connected from the VCCP pin to the BOOT pin, each time the PHASE pin drops below VCCP minus the voltage dropped across the internal boot diode.
15	17	UGATE	Output of the high-side MOSFET gate driver. Connect the UGATE pin to the gate of the high-side MOSFET.
16	18	PHASE	Current return path for the high-side MOSFET gate driver. Connect the PHASE pin to the node consisting of the high-side MOSFET source, the low-side MOSFET drain, and the output inductor.
17	19	VSSP	Current return path for the low-side MOSFET gate driver. Connect the VSSP pin to the source of the low-side MOSFET through a low impedance path, preferably in parallel with the traces connecting the LGATE pins to the gates of the low-side MOSFET.
18	-	LGATE	Output of the low-side MOSFET gate driver. Connect the LGATE1 pin to the gate of the Phase-1 low-side MOSFET.
-	20	LGATEa	Output of the low-side MOSFET gate driver that is always active. Connect the LGATEa pin to the gate of the low-side MOSFET that is active all the time.
-	21	LGATEb	Another output of the low-side MOSFET gate driver. This gate driver will be pulled low when the DPRSLPVR pin logic is high. Connect the LGATEb pin to the gate of the low-side MOSFET that is idle in deeper sleep mode.
19	22	VCCP	Input voltage bias for the internal gate drivers. Connect +5V to the VCCP pin. Decouple with at least 1μF of an MLCC capacitor to the VSSP pin.
20, 21, 22, 23, 24, 25, 26	23, 24, 25, 26, 27, 28, 29	VID0, VID1, VID2, VID3, VID4, VID5, VID6	VID input with VID0 = LSB and VID6 = MSB.
27	30	VR_ON	Voltage regulator enable input. A high level logic signal on this pin enables the regulator.
28	31	DPRSLPVR	Deeper sleep enable signal. A high level logic signal on this pin indicates that the microprocessor is in deeper sleep mode.
pad		BOTTOM	The bottom pad is electrically connected to the GND pin inside the IC. It should also be used as the thermal pad for heat removal.

Block Diagram

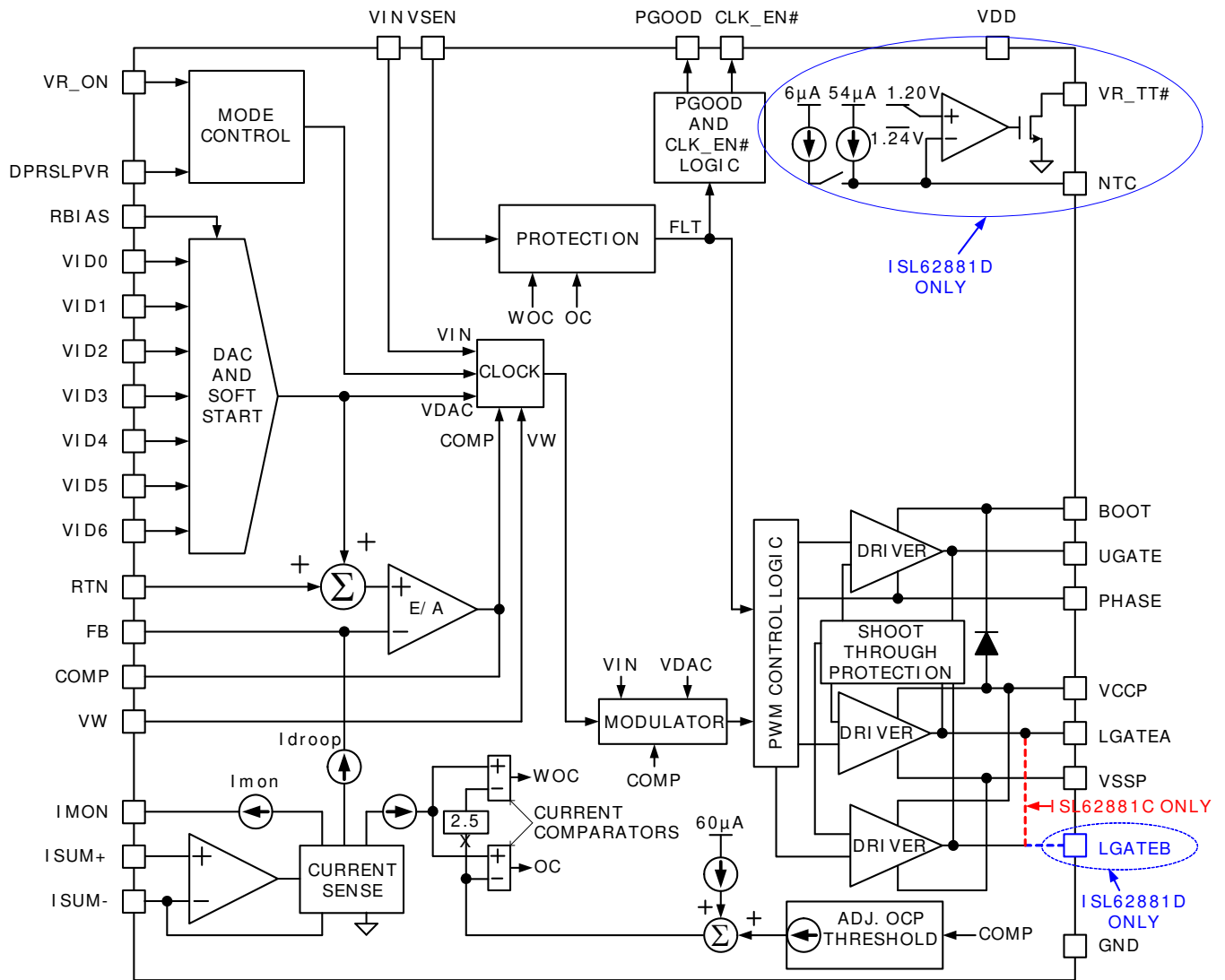

Table of Contents

Related Literature	1	Key Component Selection	18
Load Line Regulation	1	R _{BIAS}	18
Pin Function Description	2	Inductor DCR Current-Sensing Network	18
Block Diagram	4	Resistor Current-Sensing Network	20
Absolute Maximum Ratings	6	Overcurrent Protection	21
Thermal Information	6	Load Line Slope	21
Recommended Operating Conditions	6	Current Monitor	21
Electrical Specifications	6	Compensator	22
Gate Driver Timing Diagram	9	Optional Slew Rate Compensation Circuit for 1-Tick VID Transition	24
Simplified Application Circuits	9	Voltage Regulator Thermal Throttling	24
Theory of Operation	12	Layout Guidelines	25
Multiphase R3™ Modulator	12	CPU Application Reference Design	
Diode Emulation and Period Stretching	13	Bill of Materials	29
Start-up Timing	13	GPU Application Reference Design	
Voltage Regulation and Load Line Implementation	14	Bill of Materials	30
Differential Sensing	16	Typical Performance	32
CCM Switching Frequency	16	Revision History	35
Modes of Operation	16	Products	35
Dynamic Operation	16	Package Outline Drawing	
Protections	17	L28.4x4	36
Current Monitor	17	Package Outline Drawing	
Adaptive Body Diode Conduction		L32.5x5E	37
Time Reduction	18		
Overshoot Reduction Function	18		

Absolute Maximum Ratings

Supply Voltage, VDD	-0.3V to +7V
Battery Voltage, VIN	+28V
Boot Voltage (BOOT)	-0.3V to +33V
Boot to Phase Voltage (BOOT-PHASE)	-0.3V to +7V(DC) -0.3V to +9V(< 10ns)
Phase Voltage (PHASE)	-7V (< 20ns Pulse Width, 10μJ)
UGATE Voltage (UGATE)	PHASE-0.3V (DC) to BOOT PHASE-5V (< 20ns Pulse Width, 10μJ) to BOOT
LGATE Voltage (LGATE)	-0.3V (DC) to VDD + 0.3V -2.5V (< 20ns Pulse Width, 5μJ) to VDD + 0.3V
All Other Pins	-0.3V to (VDD + 0.3V)
Open Drain Outputs, PGOOD, VR_TT#, CLK_EN#	-0.3V to +7V
ESD Rating	
Human Body Model (Tested per JESD22-A114E)	2kV
Machine Model (Tested per JESD22-A115-A)	200V
Latch Up (Tested per JESD-78B; Class 2, Level A)	100mA

Thermal Information

Thermal Resistance (Typical, Notes 4, 5) θ_{JA} (°C/W) θ_{JC} (°C/W)		
28 Ld TQFN Package	42	5
32 Ld TQFN Package	34	5
Maximum Junction Temperature	+150°C	
Maximum Storage Temperature Range	-65°C to +150°C	
Pb-Free Reflow Profile	see link below http://www.intersil.com/pbfree/Pb-FreeReflow.asp	

Recommended Operating Conditions

Supply Voltage, VDD	+5V ±5%
Battery Voltage, VIN	+4.5V to 25V
Ambient Temperature	
ISL62881CHRTZ, ISL62881DHRTZ	-10°C to +100°C
ISL62881CIRTZ	-40°C to +100°C
Junction Temperature	
ISL62881CHRTZ, ISL62881DHRTZ	-10°C to +125°C
ISL62881CIRTZ	-40°C to +125°C

CAUTION: Do not operate at or near the maximum ratings listed for extended periods of time. Exposure to such conditions may adversely impact product reliability and result in failures not covered by warranty.

NOTES:

- θ_{JA} is measured in free air with the component mounted on a high effective thermal conductivity test board with “direct attach” features. See Tech Brief TB379.
- For θ_{JC} , the “case temp” location is the center of the exposed metal pad on the package underside.

Electrical Specifications Operating Conditions: V_{DD} = 5V, T_A = -40°C to +100°C, f_{SW} = 300kHz, unless otherwise noted. Boldface limits apply over the operating temperature range, -40°C to +100°C.

PARAMETER	SYMBOL	TEST CONDITIONS	MIN (Note 7)	TYP	MAX (Note 7)	UNITS
INPUT POWER SUPPLY						
+5V Supply Current	I _{VDD}	VR_ON = 1V		3.2	4.0	mA
		VR_ON = 0V			1	μA
Battery Supply Current	I _{VIN}	VR_ON = 0V			1	μA
V _{IN} Input Resistance	R _{VIN}	VR_ON = 1V		900		kΩ
Power-On-Reset Threshold	POR _r	V _{DD} rising		4.35	4.5	V
	POR _f	V _{DD} falling	4.00	4.15		V
SYSTEM AND REFERENCES						
System Accuracy	HRTZ % Error (V _{CC_CORE})	No load; closed loop, active mode range VID = 0.75V to 1.50V,	-0.5		+0.5	%
		VID = 0.5V to 0.7375V	-8		+8	mV
		VID = 0.3V to 0.4875V	-15		+15	mV
	IRTZ % Error (V _{CC_CORE})	No load; closed loop, active mode range VID = 0.75V to 1.50V	-0.8		+0.8	%
		VID = 0.5V to 0.7375V	-10		+10	mV
		VID = 0.3V to 0.4875V	-18		+18	mV
V _{BOOT}	HRTZ		1.0945	1.100	1.1055	V
	IRTZ		1.0912	1.100	1.1088	V
Maximum Output Voltage	V _{CC_CORE(max)}	VID = [0000000]		1.500		V
Minimum Output Voltage (Note 6)	V _{CC_CORE(min)}	VID = [1111111]		0		V
R _{BIAS} Voltage		R _{BIAS} = 147kΩ	1.45	1.47	1.49	V

Electrical Specifications Operating Conditions: $V_{DD} = 5V$, $T_A = -40^{\circ}C$ to $+100^{\circ}C$, $f_{SW} = 300kHz$, unless otherwise noted. Boldface limits apply over the operating temperature range, $-40^{\circ}C$ to $+100^{\circ}C$. (Continued)

PARAMETER	SYMBOL	TEST CONDITIONS	MIN (Note 7)	TYP	MAX (Note 7)	UNITS
CHANNEL FREQUENCY						
Nominal Channel Frequency	$f_{SW(nom)}$	$R_{FSET} = 7k\Omega$, $V_{COMP} = 1V$	295	310	325	kHz
Adjustment Range			200		500	kHz
AMPLIFIERS						
Current-Sense Amplifier Input Offset		$I_{FB} = 0A$	-0.15		+0.15	mV
Error Amp DC Gain (Note 6)	A_{V0}			90		dB
Error Amp Gain-Bandwidth Product (Note 6)	GBW	$C_L = 20pF$		18		MHz
POWER GOOD AND PROTECTION MONITORS						
PGOOD Low Voltage	V_{OL}	$I_{PGOOD} = 4mA$		0.26	0.4	V
PGOOD Leakage Current	I_{OH}	$PGOOD = 3.3V$	-1		1	μA
PGOOD Delay	t _{pgd}	CLK_ENABLE# LOW to PGOOD HIGH	6.3	7.6	8.9	ms
UGATE DRIVER						
UGATE Pull-Up Resistance (Note 6)	R_{UGPU}	200mA Source Current		1.0	1.5	Ω
UGATE Source Current (Note 6)	I_{UGSRC}	BOOT - UGATE = 2.5V		2.0		A
UGATE Sink Resistance (Note 6)	R_{UGPD}	250mA Sink Current		1.0	1.5	Ω
UGATE Sink Current (Note 6)	I_{UGSNK}	UGATE - PHASE = 2.5V		2.0		A
LGATE DRIVER (ISL62881C)						
LGATE Pull-Up Resistance (Note 6)	R_{LGPU}	250mA Source Current		1.0	1.5	Ω
LGATE Source Current (Note 6)	I_{LGSRC}	VCCP - LGATE = 2.5V		2.0		A
LGATE Sink Resistance (Note 6)	R_{LGPD}	250mA Sink Current		0.5	0.9	Ω
LGATE Sink Current (Note 6)	I_{LGSNK}	LGATE - VSSP = 2.5V		4.0		A
UGATE to LGATE Deadtime	t _{UGFLGR}	UGATE falling to LGATE rising, no load		23		ns
LGATE to UGATE Deadtime	t _{LGFUGR}	LGATE falling to UGATE rising, no load		28		ns
LGATE DRIVERS (ISL62881D)						
LGATEa and b Pull-Up Resistance (Note 6)	R_{LGPU}	250mA Source Current		2.0	3	Ω
LGATEa and b Source Current (Note 6)	I_{LGSRC}	VCCP - LGATEa and b = 2.5V		1.0		A
LGATEa and b Sink Resistance (Note 6)	R_{LGPD}	250mA Sink Current		1	1.8	Ω
LGATEa and b Sink Current (Note 6)	I_{LGSNK}	LGATEa and b - VSSP = 2.5V		2.0		A
UGATE to LGATEa and b Deadtime	t _{UGFLGR}	UGATE falling to LGATEa and b rising, no load		23		ns
LGATEa and b to UGATE Deadtime	t _{LGFUGR}	LGATEa and b falling to UGATE rising, no load		28		ns

Electrical Specifications Operating Conditions: $V_{DD} = 5V$, $T_A = -40^{\circ}C$ to $+100^{\circ}C$, $f_{SW} = 300kHz$, unless otherwise noted. Boldface limits apply over the operating temperature range, $-40^{\circ}C$ to $+100^{\circ}C$. (Continued)

PARAMETER	SYMBOL	TEST CONDITIONS	MIN (Note 7)	TYP	MAX (Note 7)	UNITS
BOOTSTRAP DIODE						
Forward Voltage	V_F	$PVCC = 5V$, $I_F = 2mA$		0.58		V
Reverse Leakage	I_R	$V_R = 25V$		0.2		μA
PROTECTION						
Overvoltage Threshold	OV_H	VSEN rising above setpoint for $> 1ms$	150	200	240	mV
Severe Overvoltage Threshold	OV_{HS}	VSEN rising for $> 2\mu s$	1.525	1.55	1.575	V
OC Threshold Offset		ISUM- pin current, R_{COMP} open circuit	28	30	32	μA
Undervoltage Threshold	UV_f	VSEN falling below setpoint for $> 1.2ms$	-355	-295	-235	mV
LOGIC THRESHOLDS						
VR_ON Input Low	$V_{IL(1.0V)}$				0.3	V
VR_ON Input High	$V_{IH(1.0V)}$	ISL62881CHRTZ	0.7			V
	$V_{IH(1.0V)}$	ISL62881CIRTZ	0.75			V
VID0-VID6 and DPRSLPVR Input Low	$V_{IL(1.0V)}$				0.3	V
VID0-VID6 and DPRSLPVR Input High	$V_{IH(1.0V)}$		0.7			V
THERMAL MONITOR (ISL62881D)						
NTC Source Current		NTC = 1.3V	53	60	67	μA
Over-Temperature Threshold		V (NTC) falling	1.18	1.2	1.22	V
VR_TT# Low Output Resistance	R_{TT}	$I = 20mA$		6.5	9	Ω
CLK_EN# OUTPUT LEVELS						
CLK_EN# Low Output Voltage	V_{OL}	$I = 4mA$		0.26	0.4	V
CLK_EN# Leakage Current	I_{OH}	CLK_EN# = 3.3V	-1		1	μA
CURRENT MONITOR						
IMON Output Current	I_{IMON}	ISUM- pin current = 20 μA	108	120	132	μA
		ISUM- pin current = 10 μA	54	60	66	
		ISUM- pin current = 5 μA	25.5	30	34.5	
IMON Clamp Voltage	$V_{IMONCLAMP}$			1.1	1.15	V
Current Sinking Capability				275		μA
INPUTS						
VR_ON Leakage Current	I_{VR_ON}	VR_ON = 0V	-1	0		μA
		VR_ON = 1V		0	1	μA
VIDx Leakage Current	I_{VIDx}	VIDx = 0V	-1	0		μA
		VIDx = 1V		0.45	1	μA
DPRSLPVR Leakage Current	$I_{DPRSLPVR}$	DPRSLPVR = 0V	-1	0		μA
		DPRSLPVR = 1V		0.45	1	μA
SLEW RATE						
Slew Rate (For VID Change)	SR		5		6.5	mV/ μs

NOTES:

- Limits established by characterization and are not production tested.
- Parameters with MIN and/or MAX limits are 100% tested at $+25^{\circ}C$, unless otherwise specified. Temperature limits established by characterization and are not production tested.

Gate Driver Timing Diagram

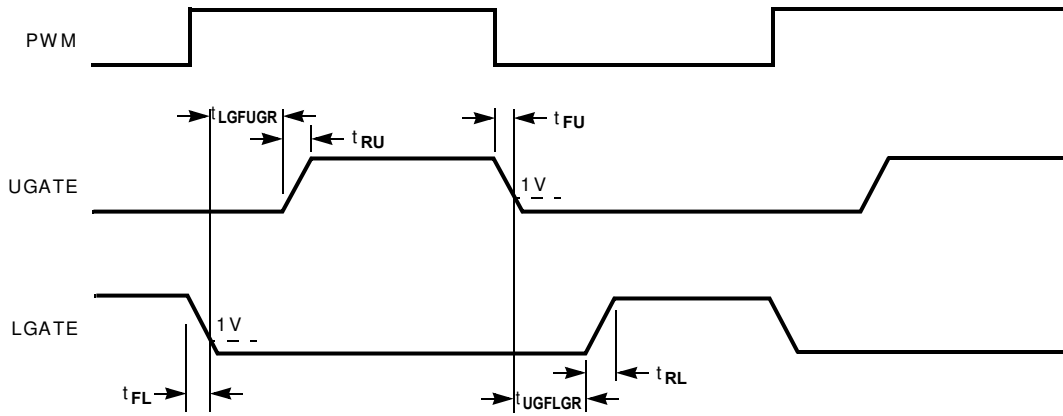

Simplified Application Circuits

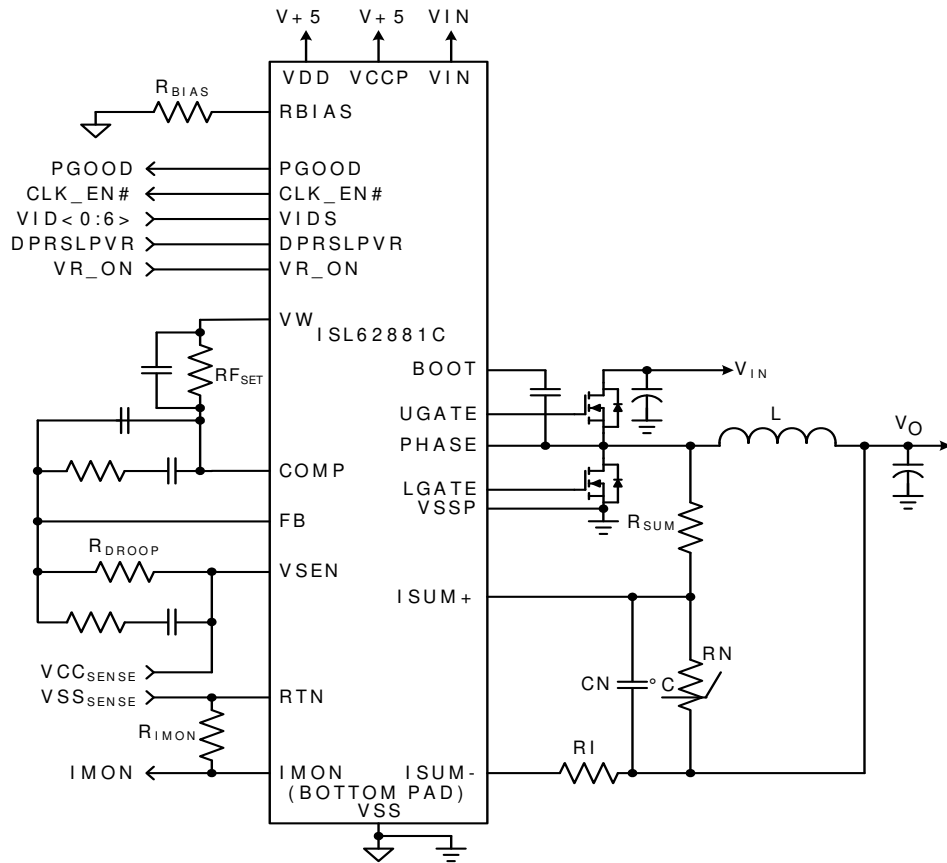

FIGURE 1. ISL62881C TYPICAL APPLICATION CIRCUIT USING DCR SENSING

Simplified Application Circuits (Continued)

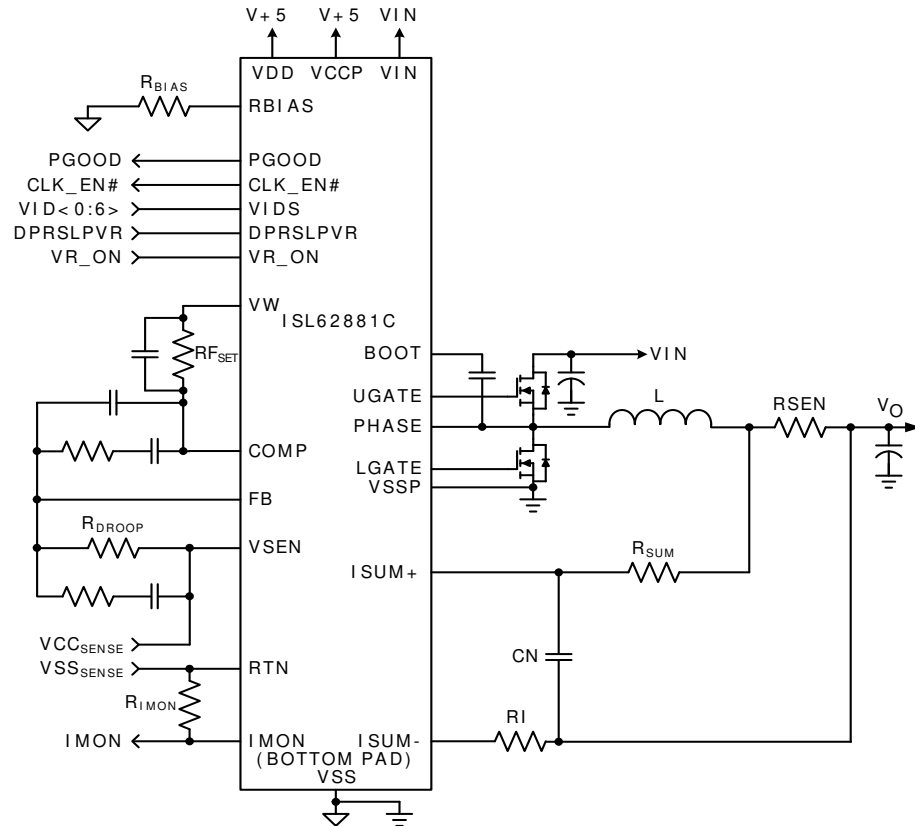

FIGURE 2. ISL62881C TYPICAL APPLICATION CIRCUIT USING RESISTOR SENSING

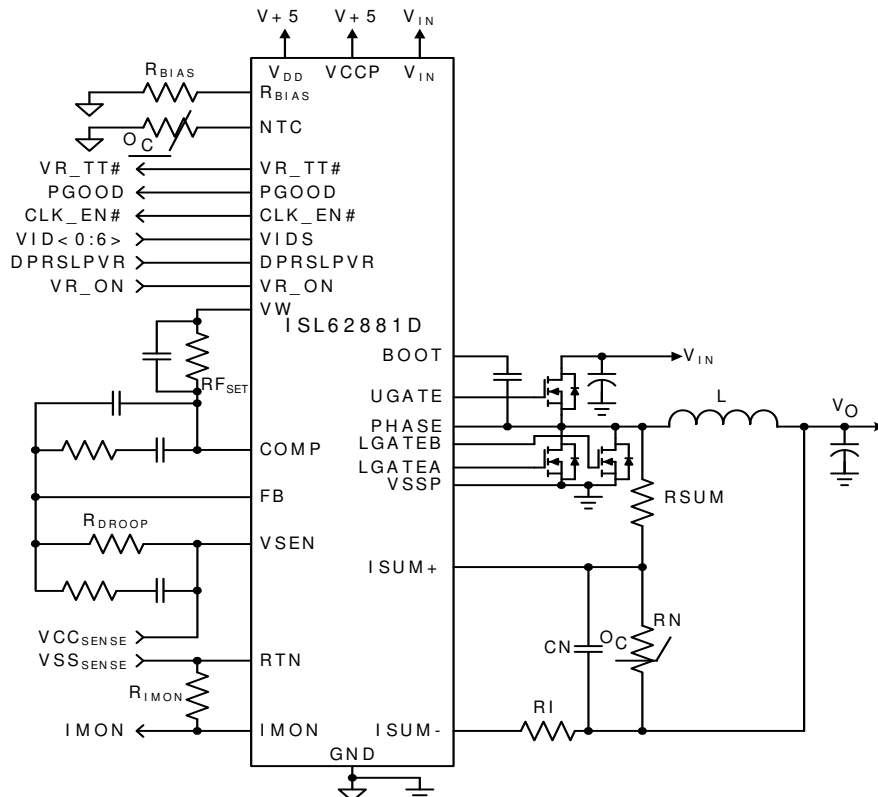

FIGURE 3. ISL62881D TYPICAL APPLICATION CIRCUIT USING DCR SENSING

Simplified Application Circuits (Continued)

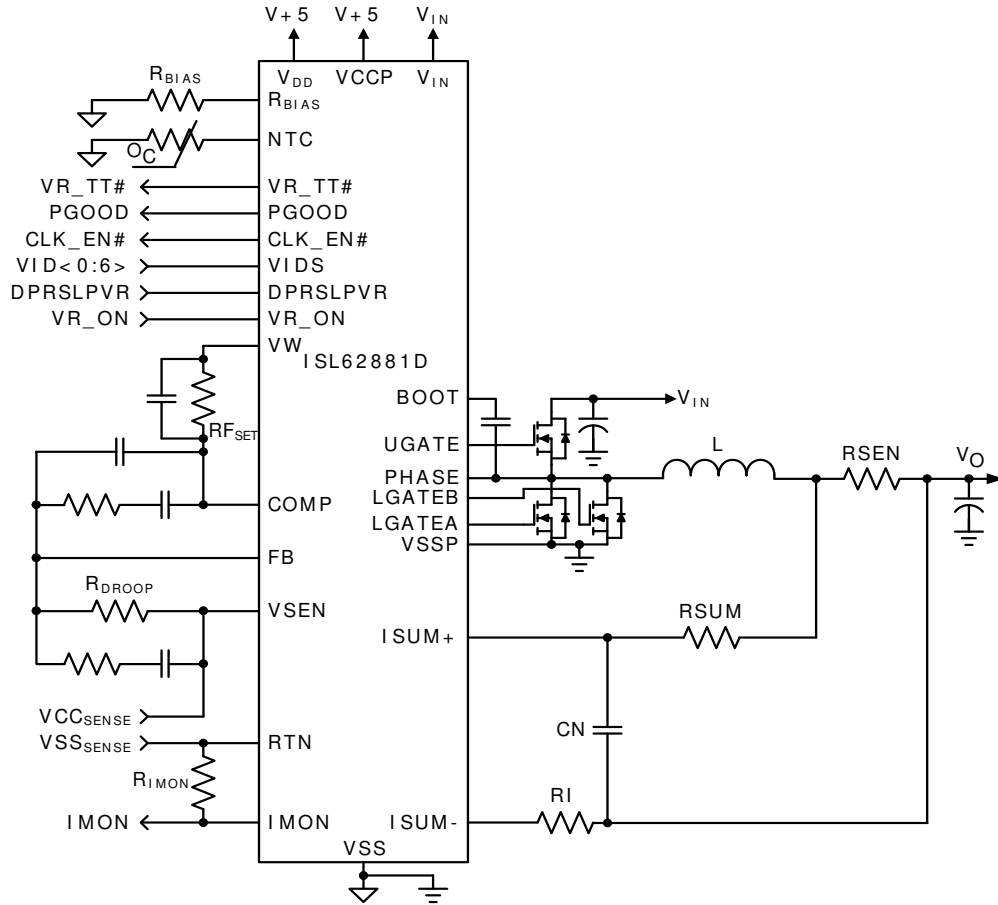

FIGURE 4. ISL62881D TYPICAL APPLICATION CIRCUIT USING RESISTOR SENSING

Theory of Operation

Multiphase R³™ Modulator

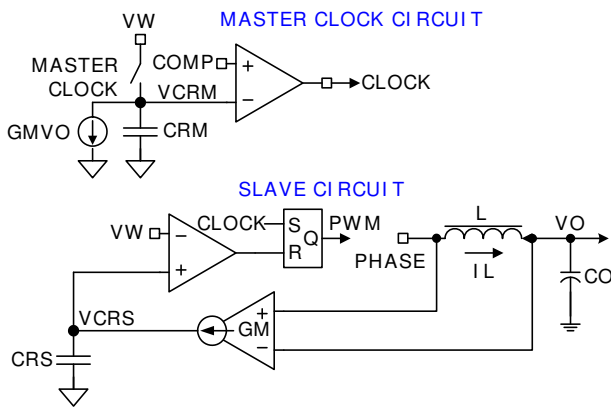

FIGURE 5. R³™ MODULATOR CIRCUIT

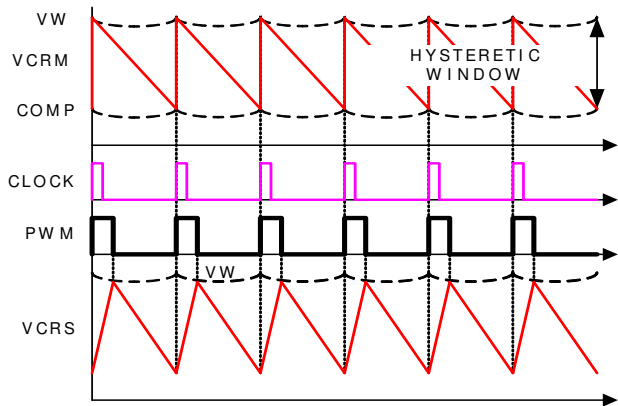

FIGURE 6. R³™ MODULATOR OPERATION PRINCIPLES IN STEADY STATE

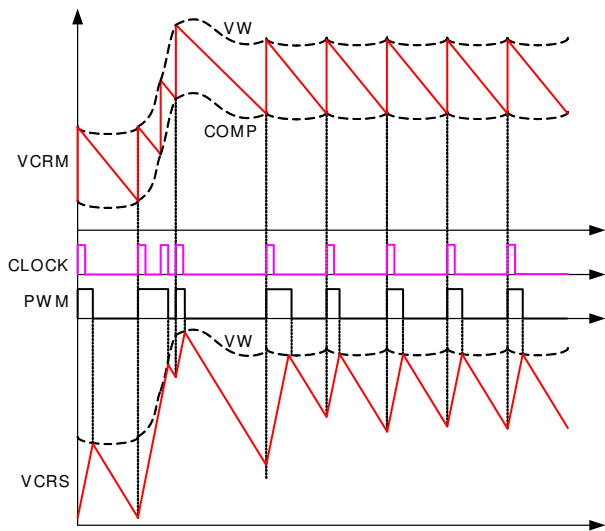

FIGURE 7. R³™ MODULATOR OPERATION PRINCIPLES IN LOAD INSERTION RESPONSE

The ISL62881C is a single-phase regulator implementing Intel® IMVP-6.5™ protocol. It uses Intersil patented R³™ (Robust Ripple Regulator™) modulator. The R³™ modulator combines the best features of fixed frequency PWM and hysteretic PWM while eliminating many of their shortcomings. Figure 5 conceptually shows the ISL62881C R³™ modulator circuit, and Figure 6 shows the operation principles.

A current source flows from the VW pin to the COMP pin, creating a voltage window set by the resistor between the two pins. This voltage window is called VW window in the following discussion.

Inside the IC, the modulator uses the master clock circuit to generate the clocks for the slave circuit. The modulator discharges the ripple capacitor C_{rm} with a current source equal to $g_m V_o$, where g_m is a gain factor. C_{rm} voltage V_{crm} is a sawtooth waveform traversing between the VW and COMP voltages. It resets to VW when it hits COMP, and generates a one-shot clock signal.

The slave circuit has its own ripple capacitor C_{rs} , whose voltage mimics the inductor ripple current. A g_m amplifier converts the inductor voltage into a current source to charge and discharge C_{rs} . The slave circuit turns on its PWM pulse upon receiving the clock signal, and the current source charges C_{rs} . When C_{rs} voltage V_{crs} hits VW, the slave circuit turns off the PWM pulse, and the current source discharges C_{rs} .

Since the ISL62881C works with V_{crs} , which is large-amplitude and noise-free synthesized signal, the ISL62881C achieves lower phase jitter than conventional hysteretic mode and fixed PWM mode controllers. Unlike conventional hysteretic mode converters, the ISL62881C has an error amplifier that allows the controller to maintain a 0.5% output voltage accuracy.

Figure 7 shows the operation principles during load insertion response. The COMP voltage rises during load insertion, generating the clock signal more quickly, so the PWM pulse turns on earlier, increasing the effective switching frequency, which allows for higher control loop bandwidth than conventional fixed frequency PWM controllers. The VW voltage rises as the COMP voltage rises, making the PWM pulse wider. During load release response, the COMP voltage falls. It takes the master clock circuit longer to generate the next clock signal so the PWM pulse is held off until needed. The VW voltage falls as the VW voltage falls, reducing the current PWM pulse width. This kind of behavior gives the ISL62881C excellent response speed.

Diode Emulation and Period Stretching

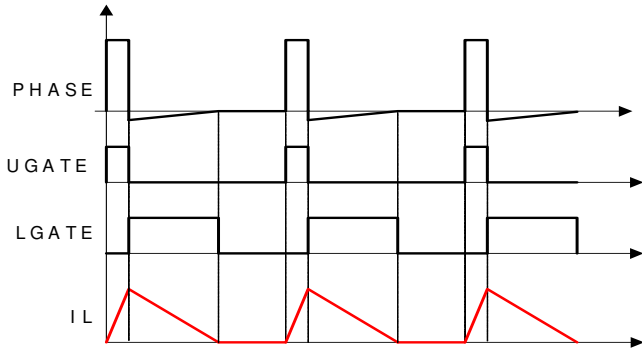

FIGURE 8. DIODE EMULATION

ISL62881C can operate in diode emulation (DE) mode to improve light load efficiency. In DE mode, the low-side MOSFET conducts when the current is flowing from source to drain and doesn't allow reverse current, emulating a diode. As shown in Figure 8, when LGATE is on, the low-side MOSFET carries current, creating negative voltage on the phase node due to the voltage drop across the ON-resistance. The ISL62881C monitors the current through monitoring the phase node voltage. It turns off LGATE when the phase node voltage reaches zero to prevent the inductor current from reversing the direction and creating unnecessary power loss.

If the load current is light enough, as Figure 9 shows, the inductor current will reach and stay at zero before the next phase node pulse, and the regulator is in discontinuous conduction mode (DCM). If the load current is heavy enough, the inductor current will never reach 0A, and the regulator is in CCM although the controller is in DE mode.

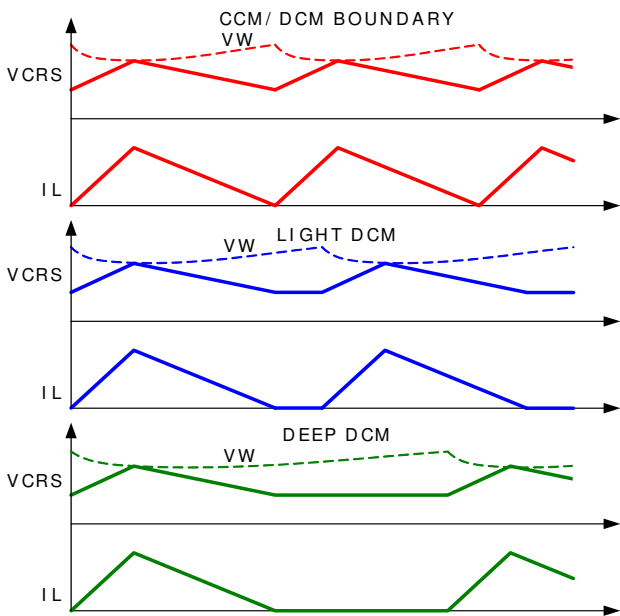

FIGURE 9. PERIOD STRETCHING

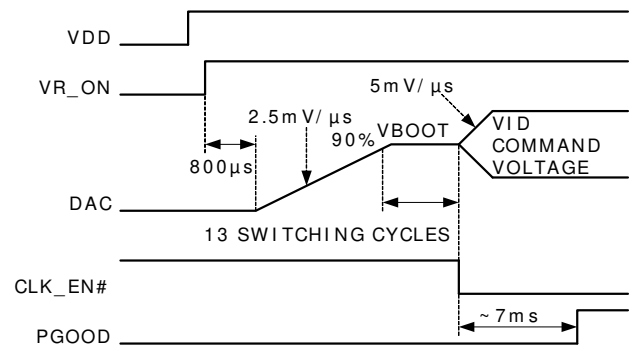

FIGURE 10. SOFT-START WAVEFORMS FOR CPU VR APPLICATION

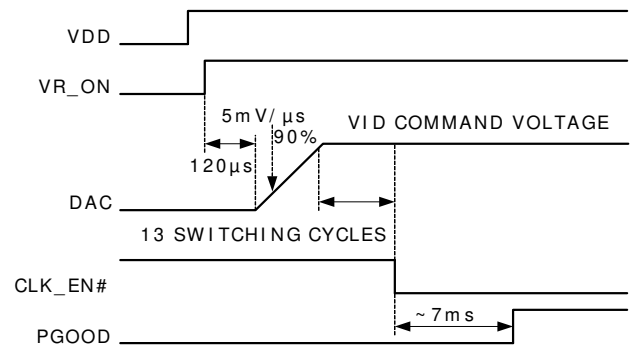

FIGURE 11. SOFT-START WAVEFORMS FOR GPU VR APPLICATION

Figure 9 shows the operation principle in diode emulation mode at light load. The load gets incrementally lighter in the three cases from top to bottom. The PWM on-time is determined by the VW window size, therefore is the same, making the inductor current triangle the same in the three cases. The ISL62881C clamps the ripple capacitor voltage V_{CRS} in DE mode to make it mimic the inductor current. It takes the COMP voltage longer to hit V_{CRS} , naturally stretching the switching period. The inductor current triangles move further apart from each other such that the inductor current average value is equal to the load current. The reduced switching frequency helps increase light load efficiency.

Start-up Timing

With the controller's V_{DD} voltage above the POR threshold, the start-up sequence begins when VR_{ON} exceeds the 3.3V logic high threshold.

Figure 10 shows the typical start-up timing when the ISL62881C is configured for CPU VR application. The ISL62881C uses digital soft-start to ramp up DAC to the boot voltage of 1.1V at about 2.5mV/µs. Once the output voltage is within 10% of the boot voltage for 13 PWM cycles (43µs for frequency = 300kHz), $CLK_{EN\#}$ is pulled low and DAC slews at 5mV/µs to the voltage set by the VID pins. $PGOOD$ is asserted high in approximately 7ms. Similar results occur if VR_{ON} is tied

to V_{DD} , with the soft-start sequence starting 120 μ s after V_{DD} crosses the POR threshold.

Figure 11 shows the typical start-up timing when the ISL62881C is configured for GPU VR application. The ISL62881C uses digital soft-start to ramp-up DAC to the voltage set by the VID pins at 5mV/ μ s. Once the output voltage is within 10% of the target voltage for 13 PWM cycles (43 μ s for frequency = 300kHz), CLK_EN# is pulled low. PGOOD is asserted high in approximately 7ms. Similar results occur if VR_ON is tied to V_{DD} , with the soft-start sequence starting 120 μ s after V_{DD} crosses the POR threshold.

Voltage Regulation and Load Line Implementation

After the start sequence, the ISL62881C regulates the output voltage to the value set by the VID inputs per Table 1. The ISL62881C will control the no-load output voltage to an accuracy of $\pm 0.5\%$ over the range of 0.75V to 1.5V. A differential amplifier allows voltage sensing for precise voltage regulation at the microprocessor die.

TABLE 1. VID TABLE

VID6	VID5	VID4	VID3	VID2	VID1	VID0	V_O (V)
0	0	0	0	0	0	0	1.5000
0	0	0	0	0	0	1	1.4875
0	0	0	0	0	1	0	1.4750
0	0	0	0	0	1	1	1.4625
0	0	0	0	1	0	0	1.4500
0	0	0	0	1	0	1	1.4375
0	0	0	0	1	1	0	1.4250
0	0	0	0	1	1	1	1.4125
0	0	0	1	0	0	0	1.4000
0	0	0	1	0	0	1	1.3875
0	0	0	1	0	1	0	1.3750
0	0	0	1	0	1	1	1.3625
0	0	0	1	1	0	0	1.3500
0	0	0	1	1	0	1	1.3375
0	0	0	1	1	1	0	1.3250
0	0	0	1	1	1	1	1.3125
0	0	1	0	0	0	0	1.3000
0	0	1	0	0	0	1	1.2875
0	0	1	0	0	1	0	1.2750
0	0	1	0	0	1	1	1.2625
0	0	1	0	1	0	0	1.2500
0	0	1	0	1	0	1	1.2375
0	0	1	0	1	1	0	1.2250
0	0	1	0	1	1	1	1.2125
0	0	1	1	0	0	0	1.2000

TABLE 1. VID TABLE (Continued)

VID6	VID5	VID4	VID3	VID2	VID1	VID0	V_O (V)
0	0	1	1	0	0	1	1.1875
0	0	1	1	0	1	0	1.1750
0	0	1	1	0	1	1	1.1625
0	0	1	1	1	0	0	1.1500
0	0	1	1	1	0	1	1.1375
0	0	1	1	1	1	0	1.1250
0	0	1	1	1	1	1	1.1125
0	1	0	0	0	0	0	1.1000
0	1	0	0	0	0	1	1.0875
0	1	0	0	0	1	0	1.0750
0	1	0	0	0	1	1	1.0625
0	1	0	0	1	0	0	1.0500
0	1	0	0	1	0	1	1.0375
0	1	0	0	1	1	0	1.0250
0	1	0	0	1	1	1	1.0125
0	1	0	1	0	0	0	1.0000
0	1	0	1	0	0	1	0.9875
0	1	0	1	0	1	0	0.9750
0	1	0	1	0	1	1	0.9625
0	1	0	1	1	0	0	0.9500
0	1	0	1	1	0	1	0.9375
0	1	0	1	1	1	0	0.9250
0	1	0	1	1	1	1	0.9125
0	1	1	0	0	0	0	0.9000
0	1	1	0	0	0	1	0.8875
0	1	1	0	0	1	0	0.8750
0	1	1	0	0	1	1	0.8625
0	1	1	0	1	0	0	0.8500
0	1	1	0	1	0	1	0.8375
0	1	1	0	1	1	0	0.8250
0	1	1	0	1	1	1	0.8125
0	1	1	1	0	0	0	0.8000
0	1	1	1	0	0	1	0.7875
0	1	1	1	0	1	0	0.7750
0	1	1	1	0	1	1	0.7625
0	1	1	1	1	0	0	0.7500
0	1	1	1	1	0	1	0.7375
0	1	1	1	1	1	0	0.7250
0	1	1	1	1	1	1	0.7125
1	0	0	0	0	0	0	0.7000
1	0	0	0	0	0	1	0.6875
1	0	0	0	0	1	0	0.6750

TABLE 1. VID TABLE (Continued)

VID6	VID5	VID4	VID3	VID2	VID1	VID0	V _O (V)
1	0	0	0	0	1	1	0.6625
1	0	0	0	1	0	0	0.6500
1	0	0	0	1	0	1	0.6375
1	0	0	0	1	1	0	0.6250
1	0	0	0	1	1	1	0.6125
1	0	0	1	0	0	0	0.6000
1	0	0	1	0	0	1	0.5875
1	0	0	1	0	1	0	0.5750
1	0	0	1	0	1	1	0.5625
1	0	0	1	1	0	0	0.5500
1	0	0	1	1	0	1	0.5375
1	0	0	1	1	1	0	0.5250
1	0	0	1	1	1	1	0.5125
1	0	1	0	0	0	0	0.5000
1	0	1	0	0	0	1	0.4875
1	0	1	0	0	1	0	0.4750
1	0	1	0	0	1	1	0.4625
1	0	1	0	1	0	0	0.4500
1	0	1	0	1	0	1	0.4375
1	0	1	0	1	1	0	0.4250
1	0	1	0	1	1	1	0.4125
1	0	1	1	0	0	0	0.4000
1	0	1	1	0	0	1	0.3875
1	0	1	1	0	1	0	0.3750
1	0	1	1	0	1	1	0.3625
1	0	1	1	1	0	0	0.3500
1	0	1	1	1	0	1	0.3375
1	0	1	1	1	1	0	0.3250
1	0	1	1	1	1	1	0.3125
1	1	0	0	0	0	0	0.3000
1	1	0	0	0	0	1	0.2875
1	1	0	0	0	1	0	0.2750
1	1	0	0	0	1	1	0.2625
1	1	0	0	1	0	0	0.2500
1	1	0	0	1	0	1	0.2375
1	1	0	0	1	1	0	0.2250
1	1	0	0	1	1	1	0.2125
1	1	0	1	0	0	0	0.2000
1	1	0	1	0	0	1	0.1875
1	1	0	1	0	1	0	0.1750

TABLE 1. VID TABLE (Continued)

VID6	VID5	VID4	VID3	VID2	VID1	VID0	V _O (V)
1	1	0	1	0	1	1	0.1625
1	1	0	1	1	0	0	0.1500
1	1	0	1	1	0	1	0.1375
1	1	0	1	1	1	0	0.1250
1	1	0	1	1	1	1	0.1125
1	1	1	0	0	0	0	0.1000
1	1	1	0	0	0	1	0.0875
1	1	1	0	0	1	0	0.0750
1	1	1	0	0	1	1	0.0625
1	1	1	0	1	0	0	0.0500
1	1	1	0	1	0	1	0.0375
1	1	1	0	1	1	0	0.0250
1	1	1	0	1	1	1	0.0125
1	1	1	1	0	0	0	0.0000
1	1	1	1	0	0	1	0.0000
1	1	1	1	0	1	0	0.0000
1	1	1	1	0	1	1	0.0000
1	1	1	1	1	0	0	0.0000
1	1	1	1	1	0	1	0.0000
1	1	1	1	1	1	0	0.0000
1	1	1	1	1	1	1	0.0000

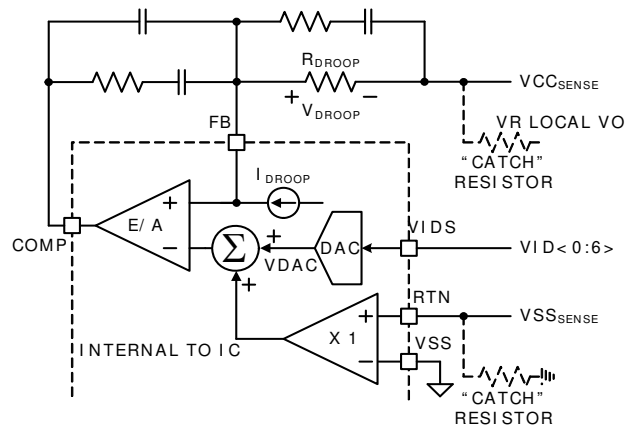

FIGURE 12. DIFFERENTIAL SENSING AND LOAD LINE IMPLEMENTATION

As the load current increases from zero, the output voltage will droop from the VID table value by an amount proportional to the load current to achieve the load line. The ISL62881C can sense the inductor current through the intrinsic DC Resistance (DCR) resistance of the inductors as shown in Figure 1 on page 9 or through resistors in series with the inductors as shown in Figure 2 on page 10. In both methods, capacitor C_n voltage represents the inductor total currents. A droop amplifier converts C_n voltage into an internal current source with

the gain set by resistor R_i . The current source is used for load line implementation, current monitor and overcurrent protection.

Figure 12 shows the load line implementation. The ISL62881C drives a current source I_{droop} out of the FB pin, described by Equation 1.

$$I_{\text{droop}} = \frac{2 \times V_{\text{Cn}}}{R_i} \quad (\text{EQ. 1})$$

When using inductor DCR current sensing, a single NTC element is used to compensate the positive temperature coefficient of the copper winding thus sustaining the load line accuracy with reduced cost.

I_{droop} flows through resistor R_{droop} and creates a voltage drop as shown in Equation 2.

$$V_{\text{droop}} = R_{\text{droop}} \times I_{\text{droop}} \quad (\text{EQ. 2})$$

V_{droop} is the droop voltage required to implement load line. Changing R_{droop} or scaling I_{droop} can both change the load line slope. Since I_{droop} also sets the overcurrent protection level, it is recommended to first scale I_{droop} based on OCP requirement, then select an appropriate R_{droop} value to obtain the desired load line slope.

Differential Sensing

Figure 12 also shows the differential voltage sensing scheme. V_{CCSENSE} and V_{SSSENSE} are the remote voltage sensing signals from the processor die. A unity gain differential amplifier senses the V_{SSSENSE} voltage and adds it to the DAC output. The error amplifier regulates the inverting and the non-inverting input voltages to be equal, therefore:

$$V_{\text{CCSENSE}} + V_{\text{droop}} = V_{\text{DAC}} + V_{\text{SSSENSE}} \quad (\text{EQ. 3})$$

Rewriting Equation 3 and substituting Equation 2 gives:

$$V_{\text{CCSENSE}} - V_{\text{SSSENSE}} = V_{\text{DAC}} - R_{\text{droop}} \times I_{\text{droop}} \quad (\text{EQ. 4})$$

Equation 4 is the exact equation required for load line implementation.

The V_{CCSENSE} and V_{SSSENSE} signals come from the processor die. The feedback will be open circuit in the absence of the processor. As shown in Figure 12, it is recommended to add a “catch” resistor to feed the VR local output voltage back to the compensator, and add another “catch” resistor to connect the VR local output ground to the RTN pin. These resistors, typically $10\Omega \sim 100\Omega$, will provide voltage feedback if the system is powered up without a processor installed.

CCM Switching Frequency

The R_{FSET} resistor between the COMP and the VW pins sets the VW windows size, which therefore sets the switching frequency. When the ISL62881C is in continuous conduction mode (CCM), the switching frequency is not absolutely constant due to the nature of the R^3 ™ modulator. As explained in “Multiphase R^3 ™ Modulator” on page 12, the effective switching frequency

will increase during load insertion and will decrease during load release to achieve fast response. On the other hand, the switching frequency is relatively constant at steady state. Variation is expected when the power stage condition, such as input voltage, output voltage, load, etc. changes. The variation is usually less than 15% and doesn't have any significant effect on output voltage ripple magnitude. Equation 5 gives an estimate of the frequency-setting resistor R_{FSET} value. $8k\Omega$ R_{FSET} gives approximately 300kHz switching frequency. Lower resistance gives higher switching frequency.

$$R_{\text{FSET}}(\text{k}\Omega) = (\text{Period}(\mu\text{s}) - 0.29) \times 2.65 \quad (\text{EQ. 5})$$

Modes of Operation

TABLE 2. ISL62881C MODES OF OPERATION

CONFIGURATION	DPRSLPVR	OPERATIONAL MODE	VOLTAGE SLEW RATE
CPU VR Application	0	1-phase CCM	5mV/μs
	1	1-phase DE	
GPU VR Application	0	1-phase CCM	5mV/μs
	1	1-phase DE	10mV/μs

Table 2 shows the ISL62881C operational modes, programmed by the logic status of the DPRSLPVR pin. The ISL62881C enters 1-phase DE mode when there is $\text{DPRSLPVR} = 1$.

When the ISL62881C is configured for GPU VR application, DPRSLPVR logic status also controls the output voltage slew rate. The slew rate is 5mV/μs for $\text{DPRSLPVR} = 0$ and is 10mV/μs for $\text{DPRSLPVR} = 1$.

Dynamic Operation

When the ISL62881C is configured for CPU VR application, it responds to VID changes by slewing to the new voltage at 5mV/μs slew rate. As the output approaches the VID command voltage, the dv/dt moderates to prevent overshoot. Geyserville-III transitions commands one LSB VID step (12.5mV) every 2.5μs, controlling the effective dv/dt at 5mV/μs. The ISL62881C is capable of 5mV/μs slew rate.

When the ISL62881C is configured for GPU VR application, it responds to VID changes by slewing to the new voltage at a slew rate set by the logic status on the DPRSLPVR pin. The slew rate is 5mV/μs when $\text{DPRSLPVR} = 0$ and is 10mV/μs when $\text{DPRSLPVR} = 1$.

When the ISL62881C is in DE mode, it will actively drive the output voltage up when the VID changes to a higher value. It'll resume DE mode operation after reaching the new voltage level. If the load is light enough to warrant DCM, it will enter DCM after the inductor current has crossed zero for four consecutive cycles. The ISL62881C will remain in DE mode when the VID changes to a lower value. The output voltage will decay to the new value and the load will determine the slew rate.

During load insertion response, the Fast Clock function increases the PWM pulse response speed. The

ISL62881C monitors the VSEN pin voltage and compares it to 100ns filtered version. When the unfiltered version is 20mV below the filtered version, the controller knows there is a fast voltage dip due to load insertion, hence issues an additional master clock signal to deliver a PWM pulse immediately.

The R³™ modulator intrinsically has voltage feed forward. The output voltage is insensitive to a fast slew rate input voltage change.

Protections

The ISL62881C provides overcurrent, undervoltage, and overvoltage protections.

The ISL62881C determines overcurrent protection (OCP) by comparing the average value of the droop current I_{droop} with an internal current source threshold. It declares OCP when I_{droop} is above the threshold for 120μs. A resistor R_{comp} from the COMP pin to GND programs the OCP current source threshold, as well as the overshoot reduction function (to be discussed in later sections), as Table 3 shows. It is recommended to use the nominal R_{comp} value. The ISL62881C detects the R_{comp} value at the beginning of start-up, and sets the internal OCP threshold accordingly. It remembers the R_{comp} value until the VR_ON signal drops below the POR threshold.

TABLE 3. ISL62881C OCP THRESHOLD AND OVERSHOOT REDUCTION FUNCTION

R _{comp}			OCP THRESHOLD (μA)	OVERSHOOT REDUCTION FUNCTION
MIN (kΩ)	NOMINAL (kΩ)	MAX (kΩ)		
	none	none	60	Disabled
305	400	410	68	
205	235	240	62	
155	165	170	54	
104	120	130	60	Enabled
78	85	90	68	
62	66	68	62	
45	50	55	54	

The default OCP threshold is the value when R_{comp} is not populated. It is recommended to scale the droop current I_{droop} such that the default OCP threshold gives approximately the desired OCP level, then use R_{comp} to fine tune the OCP level if necessary.

For overcurrent condition above 2.5x the OCP level, the PWM output will immediately shut off and PGOOD will go low to maximize protection. This protection is also referred to as way-overcurrent protection or fast-overcurrent protection, for short-circuit protections.

The ISL62881C will declare undervoltage (UV) fault and latch off if the output voltage is less than the VID set value by 300mV or more for 1ms. It'll turn off the PWM output and de-assert PGOOD.

The ISL62881C has two levels of overvoltage protections. The first level of overvoltage protection is

referred to as PGOOD overvoltage protection. If the output voltage exceeds the VID set value by +200mV for 1ms, the ISL62881C will declare a fault and de-assert PGOOD.

The ISL62881C takes the same actions for all of the above fault protections: de-assertion of PGOOD and turn-off of the high-side and low-side power MOSFETs. Any residual inductor current will decay through the MOSFET body diodes. These fault conditions can be reset by bringing VR_ON low or by bringing V_{DD} below the POR threshold. When VR_ON and V_{DD} return to their high operating levels, a soft-start will occur.

The second level of overvoltage protection is different. If the output voltage exceeds 1.55V, the ISL62881C will immediately declare an OV fault, de-assert PGOOD, and turn on the low-side power MOSFETs. The low-side power MOSFETs remain on until the output voltage is pulled down below 0.85V when all power MOSFETs are turned off. If the output voltage rises above 1.55V again, the protection process is repeated. This behavior provides the maximum amount of protection against shorted high-side power MOSFETs while preventing output ringing below ground. Resetting VR_ON cannot clear the 1.55V OVP. Only resetting V_{DD} will clear it. The 1.55V OVP is active all the time when the controller is enabled, even if one of the other faults have been declared. This ensures that the processor is protected against high-side power MOSFET leakage while the MOSFETs are commanded off.

Table 4 summarizes the fault protections.

TABLE 4. FAULT PROTECTION SUMMARY

FAULT TYPE	FAULT DURATION BEFORE PROTECTION	PROTECTION ACTION	FAULT RESET
Overcurrent	120μs	PWM tri-state, PGOOD latched low	VR_ON toggle or VDD toggle
Way-Overcurrent (2.5xOC)	< 2μs		
Overvoltage +200mV	1ms		
Undervoltage -300mV			
Overvoltage 1.55V	Immediately	Low-side MOSFET on until V _{core} < 0.85V, then PWM tri-state, PGOOD latched low.	VDD toggle

Current Monitor

The ISL62881C provides the current monitor function. The IMON pin outputs a high-speed analog current source that is 3 times of the droop current flowing out of the FB pin. Thus as shown by Equation 6.

$$I_{IMON} = 3 \times I_{droop} \quad (\text{EQ. 6})$$

As Figures 1 and 2 show, a resistor R_{iMON} is connected to the IMON pin to convert the IMON pin current to voltage. A capacitor can be paralleled with R_{iMON} to filter the voltage information. The IMVP-6.5™ specification requires that the IMON voltage information be referenced to VSS_{SENSE} .

The IMON pin voltage range is 0V to 1.1V. A clamp circuit prevents the IMON pin voltage from going above 1.1V.

Adaptive Body Diode Conduction Time Reduction

In DCM, the controller turns off the low-side MOSFET when the inductor current approaches zero. During on-time of the low-side MOSFET, phase voltage is negative and the amount is the MOSFET $r_{DS(ON)}$ voltage drop, which is proportional to the inductor current. A phase comparator inside the controller monitors the phase voltage during on-time of the low-side MOSFET and compares it with a threshold to determine the zero-crossing point of the inductor current. If the inductor current has not reached zero when the low-side MOSFET turns off, it'll flow through the low-side MOSFET body diode, causing the phase node to have a larger voltage drop until it decays to zero. If the inductor current has crossed zero and reversed the direction when the low-side MOSFET turns off, it'll flow through the high-side MOSFET body diode, causing the phase node to have a spike until it decays to zero. The controller continues monitoring the phase voltage after turning off the low-side MOSFET and adjusts the phase comparator threshold voltage accordingly in iterative steps such that the low-side MOSFET body diode conducts for approximately 40ns to minimize the body diode-related loss.

Overshoot Reduction Function

The ISL62881C has an optional overshoot reduction function, enabled or disabled by the resistor from the COMP pin to GND, as shown in Table 3.

When a load release occurs, the energy stored in the inductors will dump to the output capacitor, causing output voltage overshoot. The inductor current freewheels through the low-side MOSFET during this period of time. The overshoot reduction function turns off the low-side MOSFET during the output voltage overshoot, forcing the inductor current to freewheel through the low-side MOSFET body diode. Since the body diode voltage drop is much higher than MOSFET $R_{DS(ON)}$ voltage drop, more energy is dissipated on the low-side MOSFET therefore the output voltage overshoot is lower.

If the overshoot reduction function is enabled, the ISL62881C monitors the COMP pin voltage to determine the output voltage overshoot condition. The COMP voltage will fall and hit the clamp voltage when the output voltage overshoots. The ISL62881C will turn off LGATE when COMP is being clamped. The low-side MOSFET in the power stage will be turned off. When the output voltage has reached its peak and starts to come down, the COMP voltage starts to rise and is no longer

clamped. The ISL62881C will resume normal PWM operation.

While the overshoot reduction function reduces the output voltage overshoot, energy is dissipated on the low-side MOSFET, causing additional power loss. The more frequent the transient event, the more power loss is dissipated on the low-side MOSFET. The MOSFET may face severe thermal stress when transient events happen at a high repetitive rate. User discretion is advised when this function is enabled.

Key Component Selection

R_{BIAS}

The ISL62881C uses a resistor (1% or better tolerance is recommended) from the RBIAS pin to GND to establish highly accurate reference current sources inside the IC. Using $R_{BIAS} = 147k\Omega$ sets the controller for CPU core application and using $R_{bias} = 47k\Omega$ sets the controller for GPU core application. Do not connect any other components to this pin. Do not connect any capacitor to the RBIAS pin as it will create instability.

Care should be taken in layout that the resistor is placed very close to the RBIAS pin and that a good quality signal ground is connected to the opposite side of the R_{BIAS} resistor.

Inductor DCR Current-Sensing Network

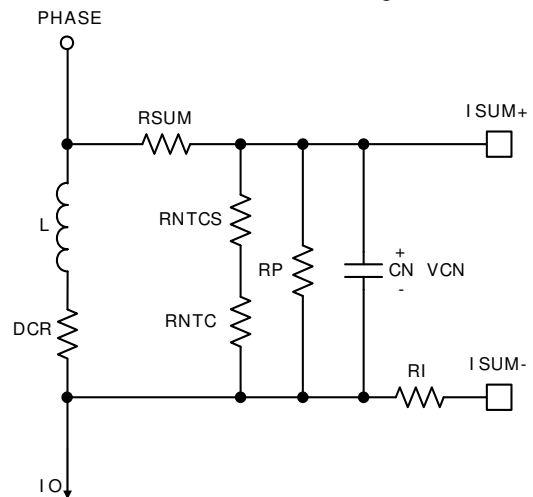

FIGURE 13. DCR CURRENT-SENSING NETWORK

Figure 13 shows the inductor DCR current-sensing network. An inductor current flows through the DCR and creates a voltage drop. The inductor has resistors in R_{SUM} connected to the phase-node-side pad and a PCB trace connected to the output-side pad to accurately sense the inductor current by sensing the DCR voltage drop. The sensed current information is fed to the NTC network (consisting of R_{ntcs} , R_{ntc} and R_p) and capacitor C_n . R_{ntc} is a negative temperature coefficient (NTC) thermistor, used to temperature-compensate the inductor DCR change. The inductor current information is presented to the capacitor C_n . Equations 7 through 11

describe the frequency-domain relationship between inductor total current $I_o(s)$ and C_n voltage $V_{Cn}(s)$:

$$V_{Cn}(s) = \left(\frac{R_{ntcnet}}{R_{ntcnet} + R_{sum}} \times DCR \right) \times I_o(s) \times A_{cs}(s) \quad (\text{EQ. 7})$$

$$R_{ntcnet} = \frac{(R_{ntcs} + R_{ntc}) \times R_p}{R_{ntcs} + R_{ntc} + R_p} \quad (\text{EQ. 8})$$

$$A_{cs}(s) = \frac{1 + \frac{s}{\omega_L}}{1 + \frac{s}{\omega_{sns}}} \quad (\text{EQ. 9})$$

$$\omega_L = \frac{DCR}{L} \quad (\text{EQ. 10})$$

$$\omega_{sns} = \frac{1}{\frac{R_{ntcnet} \times R_{sum}}{R_{ntcnet} + R_{sum}} \times C_n} \quad (\text{EQ. 11})$$

Transfer function $A_{cs}(s)$ always has unity gain at DC. The inductor DCR value increases as the winding temperature increases, giving higher reading of the inductor DC current. The NTC R_{ntc} values decreases as its temperature decreases. Proper selections of R_{sum} , R_{ntcs} , R_p and R_{ntc} parameters ensure that V_{Cn} represents the inductor total DC current over the temperature range of interest.

There are many sets of parameters that can properly temperature-compensate the DCR change. Since the NTC network and the R_{sum} resistors form a voltage divider, V_{Cn} is always a fraction of the inductor DCR voltage. It is recommended to have a higher ratio of V_{Cn} to the inductor DCR voltage, so the droop circuit has higher signal level to work with.

A typical set of parameters that provide good temperature compensation are: $R_{sum} = 1.82k\Omega$, $R_p = 11k\Omega$, $R_{ntcs} = 2.61k\Omega$ and $R_{ntc} = 10k\Omega$ (ERT-J1VR103J). The NTC network parameters may need to be fine tuned on actual boards. One can apply full load DC current and record the output voltage reading immediately; then record the output voltage reading again when the board has reached the thermal steady state. A good NTC network can limit the output voltage drift to within 2mV. It is recommended to follow the Intersil evaluation board layout and current-sensing network parameters to minimize engineering time.

$V_{Cn}(s)$ also needs to represent real-time $I_o(s)$ for the controller to achieve good transient response. Transfer function $A_{cs}(s)$ has a pole ω_{sns} and a zero ω_L . One needs to match ω_L and ω_{sns} so $A_{cs}(s)$ is unity gain at all frequencies. By forcing ω_L equal to ω_{sns} and solving for the solution, Equation 12 gives C_n value.

$$C_n = \frac{L}{\frac{R_{ntcnet} \times R_{sum}}{R_{ntcnet} + R_{sum}} \times DCR} \quad (\text{EQ. 12})$$

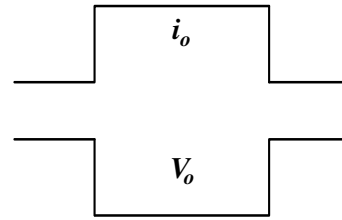

FIGURE 14. DESIRED LOAD TRANSIENT RESPONSE WAVEFORMS

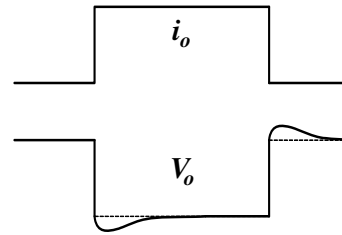

FIGURE 15. LOAD TRANSIENT RESPONSE WHEN C_n IS TOO SMALL

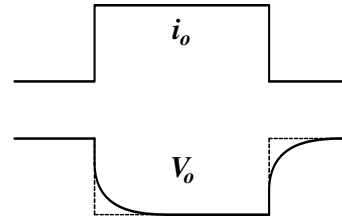

FIGURE 16. LOAD TRANSIENT RESPONSE WHEN C_n IS TOO LARGE

For example, given $R_{sum} = 1.82k\Omega$, $R_p = 11k\Omega$, $R_{ntcs} = 2.61k\Omega$, $R_{ntc} = 10k\Omega$, $DCR = 1.3m\Omega$ and $L = 0.56\mu H$, Equation 12 gives $C_n = 0.31\mu F$.

Assuming the compensator design is correct, Figure 14 shows the expected load transient response waveforms if C_n is correctly selected. When the load current I_{core} has a square change, the output voltage V_{core} also has a square response.

If C_n value is too large or too small, $V_{Cn}(s)$ will not accurately represent real-time $I_o(s)$ and will worsen the transient response. Figure 15 shows the load transient response when C_n is too small. V_{core} will sag excessively upon load insertion and may create a system failure. Figure 16 shows the transient response when C_n is too large. V_{core} is sluggish in drooping to its final value. There will be excessive overshoot if load insertion occurs during this time, which may potentially hurt the CPU reliability.

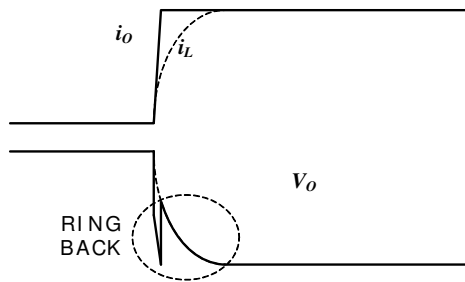

FIGURE 17. OUTPUT VOLTAGE RING BACK PROBLEM

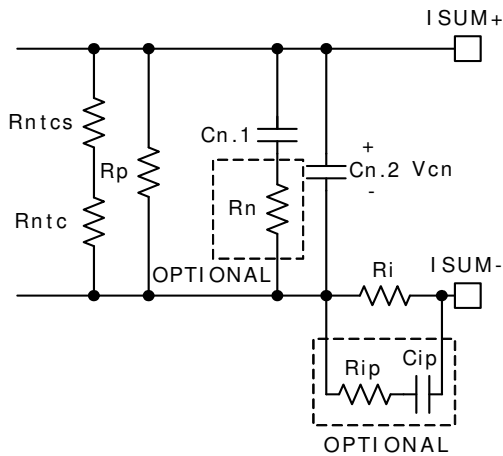

FIGURE 18. OPTIONAL CIRCUITS FOR RING BACK REDUCTION

Figure 17 shows the output voltage ring back problem during load transient response. The load current i_o has a fast step change, but the inductor current i_L cannot accurately follow. Instead, i_L responds in first order system fashion due to the nature of current loop. The ESR and ESL effect of the output capacitors makes the output voltage V_o dip quickly upon load current change. However, the controller regulates V_o according to the droop current i_{droop} , which is a real-time representation of i_L ; therefore it pulls V_o back to the level dictated by i_L , causing the ring back problem. This phenomenon is not observed when the output capacitors have very low ESR and ESL, such as all ceramic capacitors.

Figure 18 shows two optional circuits for reduction of the ring back. R_{ip} and C_{ip} form an R-C branch in parallel with R_i , providing a lower impedance path than R_i at the beginning of i_o change. R_{ip} and C_{ip} do not have any effect at steady state. Through proper selection of R_{ip} and C_{ip} values, i_{droop} can resemble i_o rather than i_L , and V_o will not ring back. The recommended value for R_{ip} is 100Ω . C_{ip} should be determined through tuning the load transient response waveforms on an actual board. The recommended range for C_{ip} is $100pF \sim 2000pF$. However, it should be noted that the $R_{ip} - C_{ip}$ branch may distort the i_{droop} waveform. Instead of being triangular as the real inductor current, i_{droop} may have sharp spikes, which may adversely affect i_{droop} average value detection and therefore may affect OCP accuracy. User discretion is advised.

C_n is the capacitor used to match the inductor time constant. It usually takes the parallel of two (or more) capacitors to get the desired value. Figure 18 shows that two capacitors $C_{n.1}$ and $C_{n.2}$ are in parallel. Resistor R_n is an optional component to reduce the V_o ring back. At steady state, $C_{n.1} + C_{n.2}$ provides the desired C_n capacitance. At the beginning of i_o change, the effective capacitance is less because R_n increases the impedance of the $C_{n.1}$ branch. As Figure 15 explains, V_o tends to dip when C_n is too small, and this effect will reduce the V_o ring back. This effect is more pronounced when $C_{n.1}$ is much larger than $C_{n.2}$. It is also more pronounced when R_n is bigger. However, the presence of R_n increases the ripple of the V_n signal if $C_{n.2}$ is too small. It is recommended to keep $C_{n.2}$ greater than $2200pF$. R_n value usually is a few ohms. $C_{n.1}$, $C_{n.2}$ and R_n values should be determined through tuning the load transient response waveforms on an actual board.

Resistor Current-Sensing Network

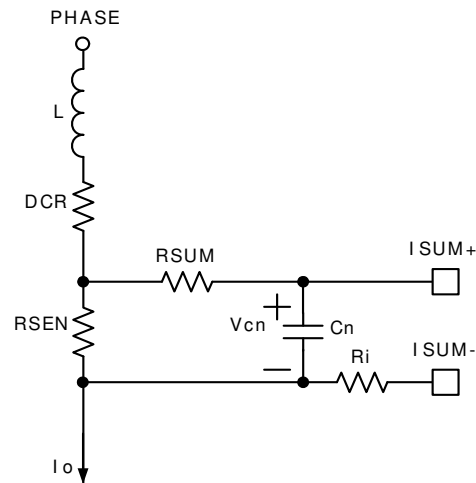

FIGURE 19. RESISTOR CURRENT-SENSING NETWORK

Figure 19 shows the resistor current-sensing network. The inductor has a series current-sensing resistor R_{sen} . R_{sum} and is connected to the R_{sen} pad to accurately capture the inductor current information. The R_{sum} feeds the sensed information to capacitor C_n . R_{sum} and C_n form a filter for noise attenuation. Equations 13 through 15 gives $V_{Cn}(s)$ expressions:

$$V_{Cn}(s) = R_{sen} \times I_o(s) \times A_{Rsen}(s) \tag{EQ. 13}$$

$$A_{Rsen}(s) = \frac{1}{1 + \frac{s}{\omega_{sns}}} \tag{EQ. 14}$$

$$\omega_{Rsen} = \frac{1}{R_{sum} \times C_n} \tag{EQ. 15}$$

Transfer function $A_{R_{sen}}(s)$ always has unity gain at DC. Current-sensing resistor R_{sen} value will not have significant variation over-temperature, so there is no need for the NTC network.

The recommended values are $R_{sum} = 1k\Omega$ and $C_n = 5600pF$.

Overcurrent Protection

Referring to Equation 1 and Figures 12, 13 and 19, resistor R_i sets the droop current I_{droop} . Table 3 shows the internal OCP threshold. It is recommended to design I_{droop} without using the R_{comp} resistor.

For example, the OCP threshold is $60\mu A$. We will design I_{droop} to be $50\mu A$ at full load, so the OCP trip level is 1.2x of the full load current.

For inductor DCR sensing, Equation 16 gives the DC relationship of $V_{Cn}(s)$ and $I_o(s)$.

$$V_{Cn} = \left(\frac{R_{ntcnet}}{R_{ntcnet} + R_{sum}} \times DCR \right) \times I_o \quad (\text{EQ. 16})$$

Substitution of Equation 16 into Equation 1 gives:

$$I_{droop} = \frac{2}{R_i} \times \frac{R_{ntcnet}}{R_{ntcnet} + R_{sum}} \times DCR \times I_o \quad (\text{EQ. 17})$$

Therefore:

$$R_i = \frac{2R_{ntcnet} \times DCR \times I_o}{(R_{ntcnet} + R_{sum}) \times I_{droop}} \quad (\text{EQ. 18})$$

Substitution of Equation 8 and application of the OCP condition in Equation 18 gives:

$$R_i = \frac{2 \times \frac{(R_{ntcs} + R_{ntc}) \times R_p}{R_{ntcs} + R_{ntc} + R_p} \times DCR \times I_{omax}}{\left(\frac{(R_{ntcs} + R_{ntc}) \times R_p}{R_{ntcs} + R_{ntc} + R_p} + R_{sum} \right) \times I_{droopmax}} \quad (\text{EQ. 19})$$

where I_{omax} is the full load current, $I_{droopmax}$ is the corresponding droop current. For example, given $R_{sum} = 1.82k\Omega$, $R_p = 11k\Omega$, $R_{ntcs} = 2.61k\Omega$, $R_{ntc} = 10k\Omega$, $DCR = 1.3m\Omega$, $I_{omax} = 22A$ and $I_{droopmax} = 50\mu A$, Equation 19 gives $R_i = 873\Omega$.

For resistor sensing, Equation 20 gives the DC relationship of $V_{Cn}(s)$ and $I_o(s)$.

$$V_{Cn} = R_{sen} \times I_o \quad (\text{EQ. 20})$$

Substitution of Equation 20 into Equation 1 gives Equation 21:

$$I_{droop} = \frac{2}{R_i} \times R_{sen} \times I_o \quad (\text{EQ. 21})$$

Therefore:

$$R_i = \frac{2R_{sen} \times I_o}{I_{droop}} \quad (\text{EQ. 22})$$

Substitution of Equation 22 and application of the OCP condition in Equation 18 gives:

$$R_i = \frac{2R_{sen} \times I_{omax}}{I_{droopmax}} \quad (\text{EQ. 23})$$

where I_{omax} is the full load current, $I_{droopmax}$ is the corresponding droop current. For example, given $R_{sen} = 1m\Omega$, $I_{omax} = 22A$ and $I_{droopmax} = 50\mu A$, Equation 23 gives $R_i = 880\Omega$.

A resistor from COMP to GND can adjust the internal OCP threshold, providing another dimension of fine-tune flexibility. Table 3 shows the detail. It is recommended to scale I_{droop} such that the default OCP threshold gives approximately the desired OCP level, then use R_{comp} to fine tune the OCP level if necessary.

Load Line Slope

Refer to Figure 12.

For inductor DCR sensing, substitution of Equation 17 into Equation 2 gives the load line slope expression in Equation 24.

$$LL = \frac{V_{droop}}{I_o} = \frac{2R_{droop}}{R_i} \times \frac{R_{ntcnet}}{R_{ntcnet} + R_{sum}} \times DCR \quad (\text{EQ. 24})$$

For resistor sensing, substitution of Equation 21 into Equation 2 gives the load line slope expression in Equation 25:

$$LL = \frac{V_{droop}}{I_o} = \frac{2R_{sen} \times R_{droop}}{R_i} \quad (\text{EQ. 25})$$

Substitution of Equation 18 and rewriting Equation 24, or substitution of Equation 22 and rewriting Equation 25 gives the same result in Equation 26:

$$R_{droop} = \frac{I_o}{I_{droop}} \times LL \quad (\text{EQ. 26})$$

One can use the full load condition to calculate R_{droop} . For example, given $I_{omax} = 22A$, $I_{droopmax} = 50\mu A$ and $LL = 7m\Omega$, Equation 26 gives $R_{droop} = 3.08k\Omega$.

It is recommended to start with the R_{droop} value calculated by Equation 26, and fine tune it on the actual board to get accurate load line slope. One should record the output voltage readings at no load and at full load for load line slope calculation. Reading the output voltage at lighter load instead of full load will increase the measurement error.

Current Monitor

Referring to Equation 6 for the IMON pin current expression.

Refer to Figures 1 and 2, the IMON pin current flows through R_{imon} . The voltage across R_{imon} is shown in Equation 27:

$$V_{Rimon} = 3 \times I_{droop} \times R_{imon} \quad (\text{EQ. 27})$$

Rewriting Equation 26 gives Equation 28:

$$I_{droop} = \frac{I_o}{R_{droop}} \times LL \quad (\text{EQ. 28})$$

Substitution of Equation 28 into Equation 27 gives Equation 29:

$$V_{R_{imon}} = \frac{3I_o \times LL}{R_{droop}} \times R_{imon} \tag{EQ. 29}$$

Rewriting Equation 29 and application of full load condition gives Equation 30:

$$R_{imon} = \frac{V_{R_{imon}} \times R_{droop}}{3I_o \times LL} \tag{EQ. 30}$$

For example, given $LL = 7m\Omega$, $R_{droop} = 3.08k\Omega$, $V_{R_{imon}} = 999mV$ at $I_{omax} = 22A$, Equation 30 gives $R_{imon} = 6.66k\Omega$

A capacitor C_{imon} can be paralleled with R_{imon} to filter the IMON pin voltage. The $R_{imon}C_{imon}$ time constant is the user's choice. It is recommended to have a time constant long enough such that switching frequency ripples are removed.

Compensator

Figure 14 shows the desired load transient response waveforms. Figure 20 shows the equivalent circuit of a voltage regulator (VR) with the droop function. A VR is equivalent to a voltage source (= VID) and output impedance $Z_{out}(s)$. If $Z_{out}(s)$ is equal to the load line slope LL, i.e. constant output impedance, in the entire frequency range, V_o will have square response when I_o has a square change.

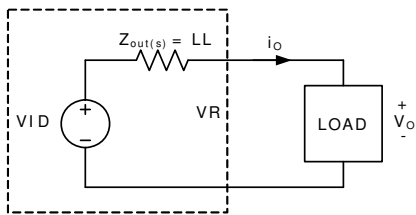

FIGURE 20. VOLTAGE REGULATOR EQUIVALENT

Intersil provides a Microsoft Excel-based spreadsheet to help design the compensator and the current sensing network, so the VR achieves constant output impedance as a stable system. Figure 23 shows a screenshot of the spreadsheet.

A VR with active droop function is a dual-loop system consisting of a voltage loop and a droop loop which is a current loop. However, neither loop alone is sufficient to describe the entire system. The spreadsheet shows two loop gain transfer functions, $T1(s)$ and $T2(s)$, that describe the entire system. Figure 21 conceptually shows $T1(s)$ measurement set-up and Figure 22 conceptually shows $T2(s)$ measurement set-up. The VR senses the inductor current, multiplies it by a gain of the load line slope, then adds it on top of the sensed output voltage and feeds it to the compensator. $T(1)$ is measured after the summing node, and $T2(s)$ is measured in the voltage loop before the summing node. The spreadsheet gives both $T1(s)$ and $T2(s)$ plots. However, only $T2(s)$ can be actually measured on an ISL62881C regulator.

$T1(s)$ is the total loop gain of the voltage loop and the droop loop. It always has a higher crossover frequency than $T2(s)$ and has more meaning of system stability.

$T2(s)$ is the voltage loop gain with closed droop loop. It has more meaning of output voltage response.

Design the compensator to get stable $T1(s)$ and $T2(s)$ with sufficient phase margin, and output impedance equal or smaller than the load line slope.

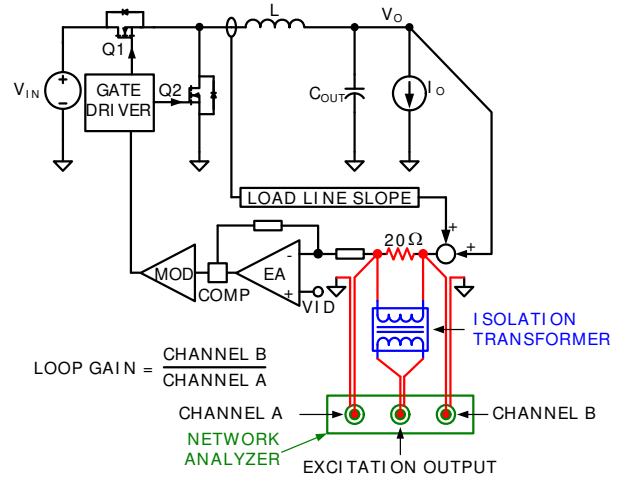

FIGURE 21. LOOP GAIN $T1(s)$ MEASUREMENT SET-UP

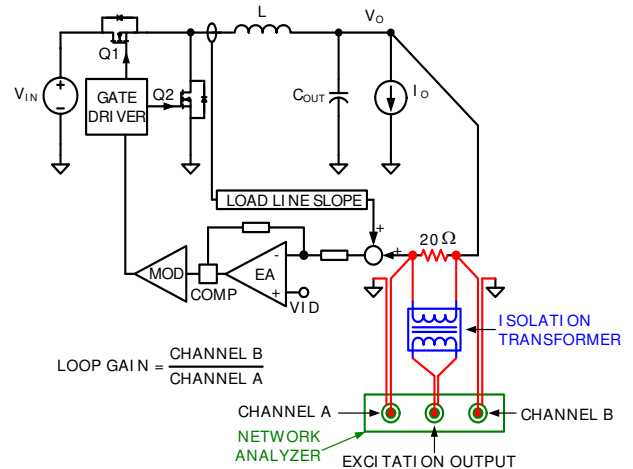

FIGURE 22. LOOP GAIN $T2(s)$ MEASUREMENT SET-UP

Compensation & Current Sensing Network Design for Intersil Multiphase R^3 Regulators for IMVP-6.5

Jia Wei, jwei@intersil.com, 919-405-3605

Attention: 1. "Analysis ToolPak" Add-in is required. To turn on, go to Tools--Add-Ins, and check "Analysis ToolPak".

2. Green cells require user input

Operation Parameters	
Controller Part Number:	ISL6288x
Phase Number:	2
Vin:	12 volts
Vo:	1.15 volts
Full Load Current:	50 Amps
Estimated Full-Load Efficiency:	87 %
Number of Output Bulk Capacitors:	3
Capacitance of Each Output Bulk Capacitor:	470 uF
ESR of Each Output Bulk Capacitor:	4.5 mΩ
ESL of Each Output Bulk Capacitor:	0.6 nH
Number of Output Ceramic Capacitors:	30
Capacitance of Each Output Ceramic Capacitor:	10 uF
ESR of Each Output Ceramic Capacitor:	3 mΩ
ESL of Each Output Ceramic Capacitor:	3 nH
Switching Frequency:	300 kHz
Inductance Per Phase:	0.36 uH
CPU Socket Resistance:	0.9 mΩ
Desired Load-Line Slope:	1.9 mΩ
Desired ISUM- Pin Current at Full Load:	33.1 uA
(This sets the over-current protection level)	

Changing the settings in red requires deep understanding of control loop design

Place the 2nd compensator pole fp2 at: 1.9 xfs (Switching Frequency)

Tune Kwi to get the desired loop gain bandwidth

Tune the compensator gain factor Kwi: 1.15
 (Recommended Kwi range is 0.8~2)

Compensator Parameters

$$A_v(s) = \frac{K_{oi} \cdot \omega_i \cdot \left(1 + \frac{s}{2f_{z1}}\right) \cdot \left(1 + \frac{s}{2f_{z2}}\right)}{s \cdot \left(1 + \frac{s}{2f_{p1}}\right) \cdot \left(1 + \frac{s}{2f_{p2}}\right)}$$

Recommended Value	User-Selected Value
R1: 2.870 kΩ	R1: 2.87 kΩ
R2: 387.248 kΩ	R2: 412 kΩ
R3: 0.560 kΩ	R3: 0.562 kΩ
C1: 188.980 pF	C1: 150 pF
C2: 498.514 pF	C2: 390 pF
C3: 32.245 pF	C3: 32 pF

Use User-Selected Value (Y/N)? N

Performance and Stability

T1 Bandwidth:	190kHz	T2 Bandwidth:	52kHz
T1 Phase Margin:	63.4°	T2 Phase Margin:	94.7°

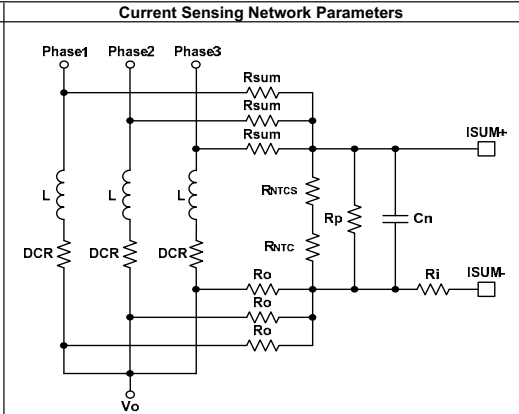

Operation Parameters

Inductor DCR	0.88 mΩ
Rsum	3.65 kΩ
Rntc	10 kΩ
Rntcs	2.61 kΩ
Rp	11 kΩ

Recommended Value	User Selected Value
Cn: 0.294 uF	Cn: 0.294 uF
Ri: 1014.245 Ω	Ri: 1000 Ω

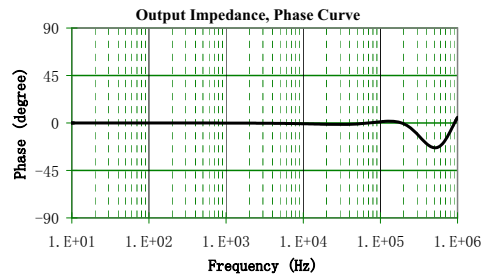
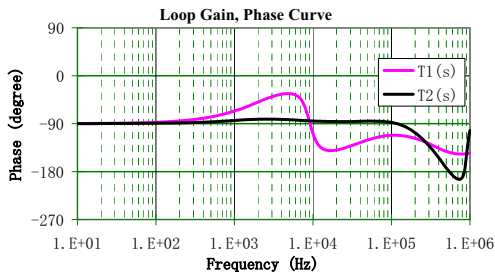
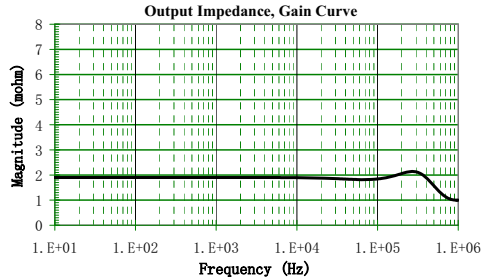
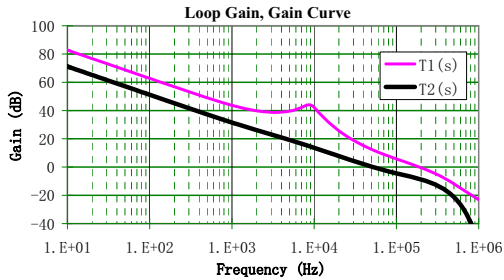

FIGURE 23. SCREENSHOT OF THE COMPENSATOR DESIGN SPREADSHEET

Optional Slew Rate Compensation Circuit for 1-Tick VID Transition

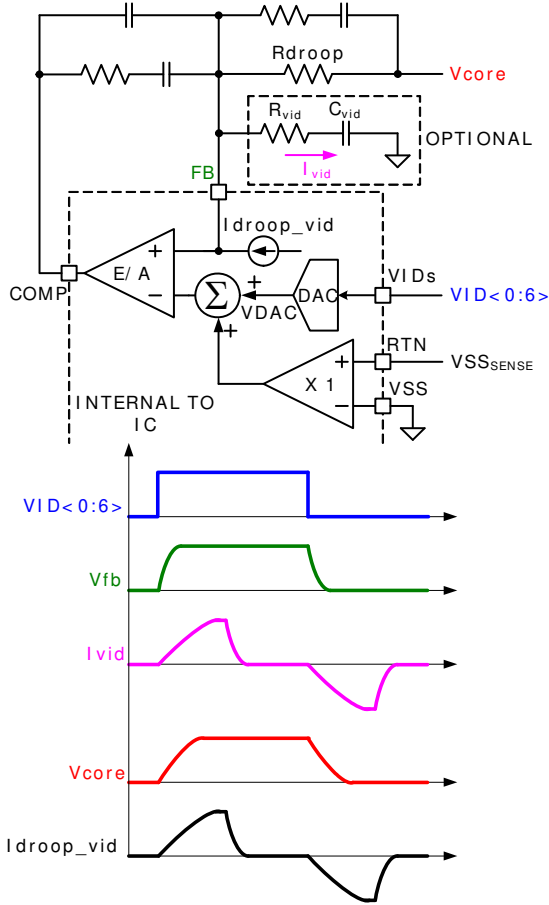

FIGURE 24. OPTIONAL SLEW RATE COMPENSATION CIRCUIT FOR 1-TICK VID TRANSITION

During a large VID transition, the DAC steps through the VIDs at a controlled slew rate of 2.5µs or 1.25µs per tick (12.5mV), controlling output voltage V_{core} slew rate at 5mV/µs or 10mV/µs.

Figure 24 shows the waveforms of 1-tick VID transition. During 1-tick VID transition, the DAC output changes at approximately 15mV/µs slew rate, but the DAC cannot step through multiple VIDs to control the slew rate. Instead, the control loop response speed determines V_{core} slew rate. Ideally, V_{core} will follow the FB pin voltage slew rate. However, the controller senses the inductor current increase during the up transition, as the I_{droop_vid} waveform shows, and will droop the output voltage V_{core} accordingly, making V_{core} slew rate slow. Similar behavior occurs during the down transition.

To control V_{core} slew rate during 1-tick VID transition, one can add the R_{vid}-C_{vid} branch, whose current I_{vid} cancels I_{droop_vid}.

When V_{core} increases, the time domain expression of the induced I_{droop} change is as shown in Equation 31:

$$I_{droop}(t) = \frac{C_{out} \times LL}{R_{droop}} \times \frac{dV_{core}}{dt} \times \left(1 - e^{-\frac{t}{C_{out} \times LL}} \right) \quad (EQ. 31)$$

where C_{out} is the total output capacitance.

In the meantime, the R_{vid}-C_{vid} branch current I_{vid} time domain expression is as shown in Equation 32:

$$I_{vid}(t) = C_{vid} \times \frac{dV_{fb}}{dt} \times \left(1 - e^{-\frac{t}{R_{vid} \times C_{vid}}} \right) \quad (EQ. 32)$$

It is desired to let I_{vid}(t) cancel I_{droop_vid}(t). So there are:

$$C_{vid} \times \frac{dV_{fb}}{dt} = \frac{C_{out} \times LL}{R_{droop}} \times \frac{dV_{core}}{dt} \quad (EQ. 33)$$

and:

$$R_{vid} \times C_{vid} = C_{out} \times LL \quad (EQ. 34)$$

The result is:

$$R_{vid} = R_{droop} \quad (EQ. 35)$$

and:

$$C_{vid} = \frac{C_{out} \times LL}{R_{droop}} \times \frac{\frac{dV_{core}}{dt}}{\frac{dV_{fb}}{dt}} \quad (EQ. 36)$$

For example: given LL = 7mΩ, R_{droop} = 3.08kΩ, C_{out} = 500µF, dV_{core}/dt = 10mV/µs and dV_{fb}/dt = 15mV/µs, Equation 35 gives R_{vid} = 3.08kΩ and Equation 36 gives C_{vid} = 757pF.

It's recommended to select the calculated R_{vid} value and start with the calculated C_{vid} value and tweak it on the actual board to get the best performance.

During normal transient response, the FB pin voltage is held constant, therefore is virtual ground in small signal sense. The R_{vid}-C_{vid} network is between the virtual ground and the real ground, and hence has no effect on transient response.

Voltage Regulator Thermal Throttling

Figure 25 shows the thermal throttling feature with hysteresis. An NTC network is connected between the NTC pin and GND. At low temperature, SW1 is on and SW2 connects to the 1.20V side. The total current flowing out of the NTC pin is 60µA. The voltage on NTC pin is higher than the threshold voltage of 1.20V and the comparator output is low. VR_TT# is pulled up by the external resistor.

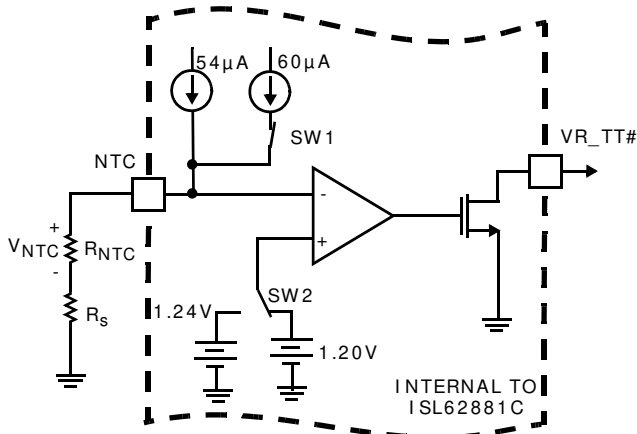

FIGURE 25. CIRCUITRY ASSOCIATED WITH THE THERMAL THROTTLING FEATURE OF THE ISL62881C

When temperature increases, the NTC thermistor resistance decreases so the NTC pin voltage drops. When the NTC pin voltage drops below 1.20V, the comparator changes polarity and turns SW1 off and throws SW2 to 1.24V. This pulls VR_TT# low and sends the signal to start thermal throttle. There is a 6µA current reduction on NTC pin and 40mV voltage increase on threshold voltage of the comparator in this state. The VR_TT# signal will be used to change the CPU operation and decrease the power consumption. When the temperature drops down, the NTC thermistor voltage will go up. If NTC voltage increases to above 1.24V, the comparator will flip back. The external resistance difference in these two conditions is shown in Equation 37:

$$\frac{1.24V}{54\mu A} - \frac{1.20V}{60\mu A} = 2.96k \quad (EQ. 37)$$

One needs to properly select the NTC thermistor value such that the required temperature hysteresis correlates to 2.96kΩ resistance change. A regular resistor may need to be in series with the NTC thermistor to meet the threshold voltage values.

For example, given Panasonic NTC thermistor with B = 4700, the resistance will drop to 0.03322 of its nominal at +105°C, and drop to 0.03956 of its nominal at +100°C. If the required temperature hysteresis is +105°C to +100°C, the required resistance of NTC will be as shown in Equation 38:

$$\frac{2.96k\Omega}{(0.03956 - 0.03322)} = 467k\Omega \quad (EQ. 38)$$

Therefore, a larger value thermistor such as 470k NTC should be used.

At +105°C, 470kΩ NTC resistance becomes (0.03322 × 470kΩ) = 15.6kΩ. With 60µA on the NTC pin, the voltage is only (15.6kΩ × 60µA) = 0.937V. This value is much lower than the threshold voltage of 1.20V.

Therefore, a regular resistor needs to be in series with the NTC. The required resistance can be calculated by Equation 39:

$$\frac{1.20V}{60\mu A} - 15.6k\Omega = 4.4k\Omega \quad (EQ. 39)$$

4.42k is a standard resistor value. Therefore, the NTC branch should have a 470k NTC and 4.42k resistor in series. The part number for the NTC thermistor is ERTJ0EV474J. It is a 0402 package. NTC thermistor will be placed in the hot spot of the board.

Layout Guidelines

Table 5 shows the layout considerations. The designators refer to the reference designs shown in Figures 26 and 27.

TABLE 5. LAYOUT CONSIDERATIONS

NAME	LAYOUT CONSIDERATION
GND	Create analog ground plane underneath the controller and the analog signal processing components. Don't let the power ground plane overlap with the analog ground plane. Avoid noisy planes/traces (e.g.: phase node) from crossing over/overlapping with the analog plane.
CLK_EN#	No special consideration.
PGOOD	No special consideration
RBIAS	Place the RBIAS resistor (R16) in general proximity of the controller. Low impedance connection to the analog ground plane.
VR_TT#	No special consideration.
NTC	The NTC thermistor (R9) needs to be placed close to the thermal source that is monitor to determine thermal throttling. Usually it's placed close to phase-1 high-side MOSFET.
VW	Place capacitor (C4) across VW and COMP in close proximity of the controller.
COMP	Place compensator components (C3, C5, C6 R7, R11, R10 and C11) in general proximity of the controller.
FB	

TABLE 5. LAYOUT CONSIDERATIONS (Continued)

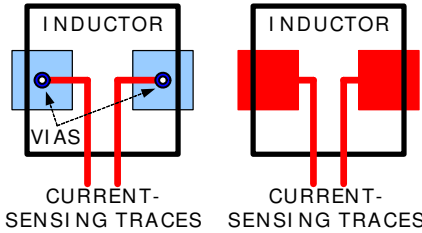
NAME	LAYOUT CONSIDERATION
VSEN	Place the VSEN/RTN filter (C12, C13) in close proximity of the controller for good decoupling.
RTN	
VDD	A capacitor (C16) decouples it to GND. Place it in close proximity of the controller.
IMON	Place the filter capacitor (C21) close to the CPU.
ISUM-	Place the current sensing circuit in general proximity of the controller.
ISUM+	Place C82 very close to the controller. Place NTC thermistors R ₄₂ next to inductor (L1) so it senses the inductor temperature correctly. The power stage sends a pair of VSUM+ and VSUM- signals to the controller. Run these two signal traces in parallel fashion with decent width (>20mil). IMPORTANT: Sense the inductor current by routing the sensing circuit to the inductor pads. Route R ₆₃ to the phase-node side pad of inductor L1. Route the other current sensing trace to the output side pad of inductor L1. If possible, route the traces on a different layer from the inductor pad layer and use vias to connect the traces to the center of the pads. If no via is allowed on the pad, consider routing the traces into the pads from the inside of the inductor. The following drawings show the two preferred ways of routing current sensing traces.
	
VIN	A capacitor (C17) decouples it to GND. Place it in close proximity of the controller.
BOOT	Use decent wide trace (>30mil). Avoid any sensitive analog signal trace from crossing over or getting close.
UGATE	Run these two traces in parallel fashion with decent width (>30mil). Avoid any sensitive analog signal trace from crossing over or getting close. Recommend routing PHASE trace to the high-side MOSFET (Q2 and Q8) source pins instead of general phase node copper.
PHASE	
VSSP	Run these two traces in parallel fashion with decent width (>30mil). Avoid any sensitive analog signal trace from crossing over or getting close. Recommend routing VSSP to the low-side MOSFET (Q3 and Q9) source pins instead of general power ground plane for better performance.
LGATE or LGATEa and LGATEb	
VCCP	A capacitor (C22) decouples it to GND. Place it in close proximity of the controller.
VID0~6	No special consideration.
VR_ON	No special consideration.
DPRSLPVR	No special consideration.
Phase Node	Minimize phase node copper area. Don't let the phase node copper overlap with/getting close to other sensitive traces. Cut the power ground plane to avoid overlapping with phase node copper.
	Minimize the loop consisting of input capacitor, high-side MOSFETs and low-side MOSFETs (e.g.: C27, C33, Q2, Q8, Q3 and Q9).

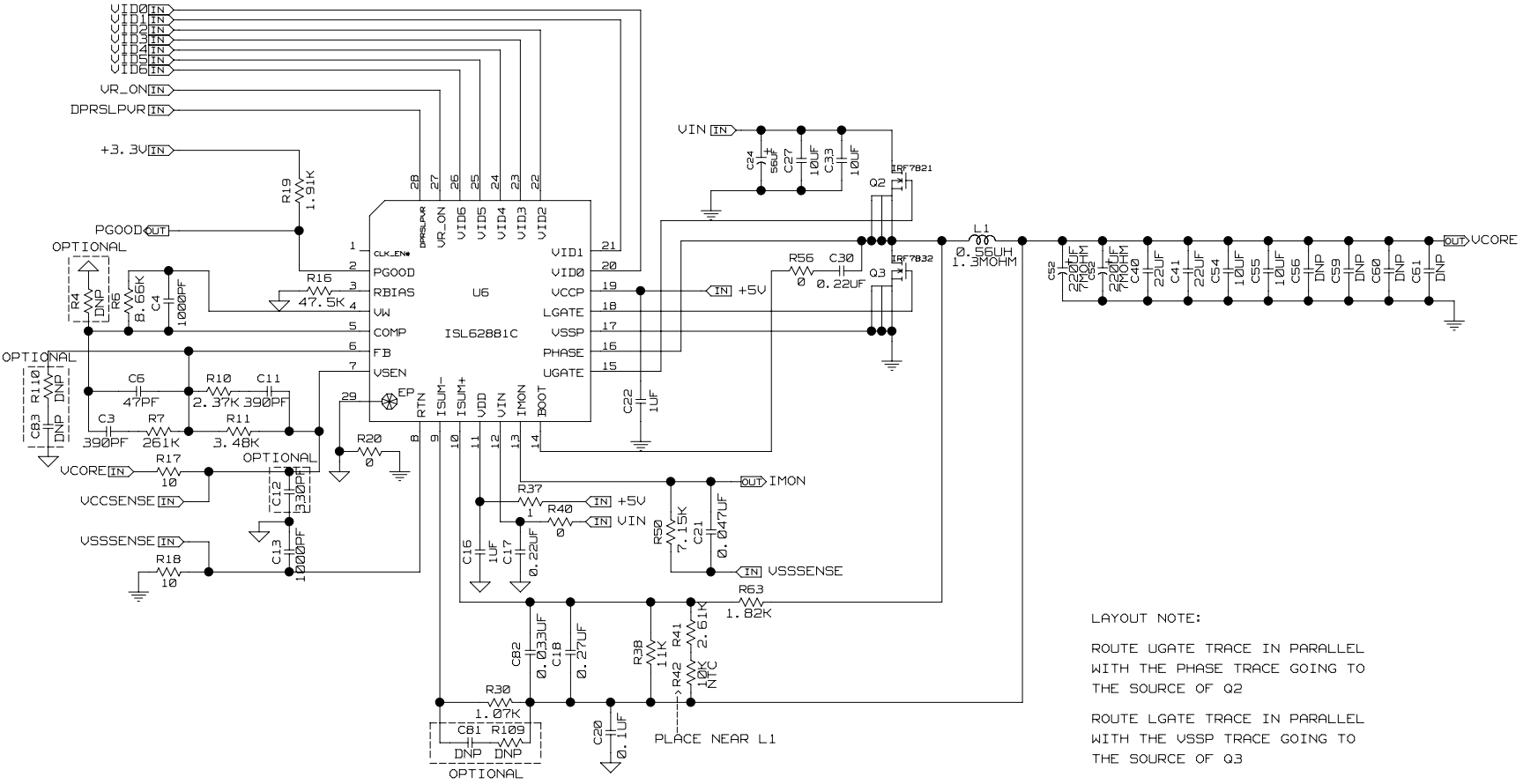
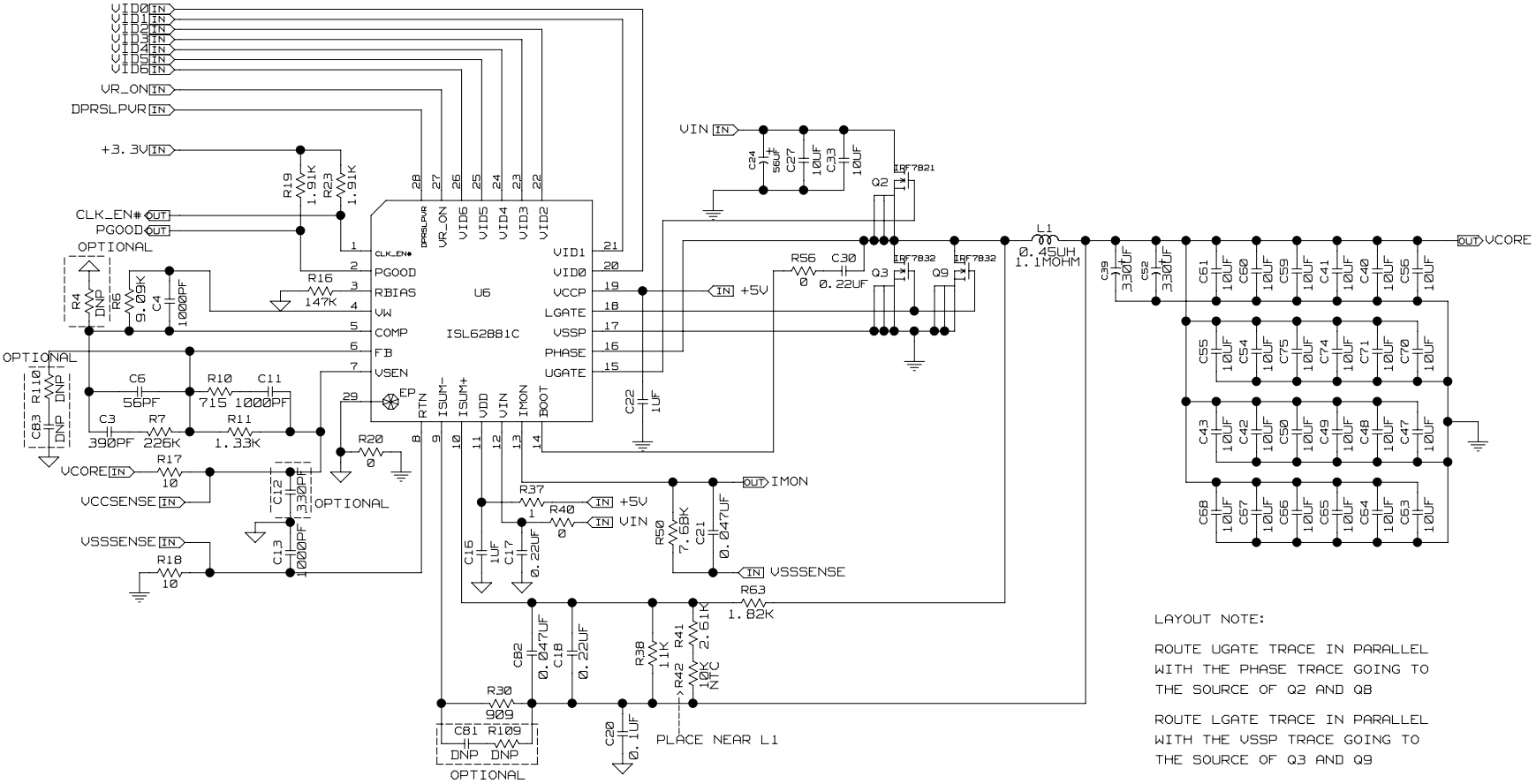

FIGURE 26. GPU APPLICATION REFERENCE DESIGN

LAYOUT NOTE:
 ROUTE LGATE TRACE IN PARALLEL WITH THE PHASE TRACE GOING TO THE SOURCE OF Q2
 ROUTE LGATE TRACE IN PARALLEL WITH THE VSSP TRACE GOING TO THE SOURCE OF Q3



LAYOUT NOTE:
 ROUTE UGATE TRACE IN PARALLEL WITH THE PHASE TRACE GOING TO THE SOURCE OF Q2 AND Q8
 ROUTE LGATE TRACE IN PARALLEL WITH THE VSSP TRACE GOING TO THE SOURCE OF Q3 AND Q9

FIGURE 27. CPU APPLICATION REFERENCE DESIGN

CPU Application Reference Design Bill of Materials

QTY	REFERENCE	VALUE	DESCRIPTION	MANUFACTURER	PART NUMBER	PACKAGE
1	C11	1000pF	Multilayer Cap, 16V, 10%	GENERIC	H1045-00102-16V10	SM0603
1	C12	330pF	Multilayer Cap, 16V, 10%	GENERIC	H1045-00331-16V10	SM0603
1	C13	1000pF	Multilayer Cap, 16V, 10%	GENERIC	H1045-00102-16V10	SM0603
2	C16, C22	1μF	Multilayer Cap, 16V, 20%	GENERIC	H1045-00105-16V20	SM0603
1	C18	0.22μF	Multilayer Cap, 16V, 10%	GENERIC	H1045-00224-16V10	SM0603
1	C20	0.1μF	Multilayer Cap, 16V, 10%	GENERIC	H1045-00104-16V10	SM0603
1	C21	0.047μF	Multilayer Cap, 16V, 10%	GENERIC	H1045-00473-16V10	SM0603
2	C17, C30	0.22μF	Multilayer Cap, 25V, 10%	GENERIC	H1045-00224-25V10	SM0603
1	C24	56μF	Radial SP Series Cap, 25V, 20%	SANYO	25SP56M	CASE-CC
2	C27, C33	10μF	Multilayer Cap, 25V, 20%	GENERIC	H1065-00106-25V20	SM1206
1	C3	390pF	Multilayer Cap, 16V, 10%	GENERIC	H1045-00391-16V10	SM0603
2	C39, C52	330μF	SPCAP, 2V, 4MΩ	PANASONIC	EEXSX0D331E4	
			POLYMER CAP, 2.5V, 4.5MΩ	KEMET	T520V337M2R5A(1)E4R5-6666	
1	C4	1000pF	Multilayer Cap, 16V, 10%	GENERIC	H1045-00102-16V10	SM0603
30	C40-C43, C47-C50, C53-C56, C59, C75, C78	10μF	Multilayer Cap, 6.3V, 20%	TAIYO MURATA Kyocera TDK	JMK212BJ106MG-T GRM21BR60J106ME19 CM21X5R106M06AT C2012X5R0J106MT009N	SM0805
1	C6	56pF	Multilayer Cap, 16V, 10%	GENERIC	H1045-00560-16V10	SM0603
1	C82	0.047μF	Multilayer Cap, 16V, 10%	GENERIC	H1045-00473-16V10	SM0603
0	C81, C83	DNP				
1	L1	0.45μH	Inductor, Inductance 20%, DCR 7%	PANASONIC NEC-TOKIN	ETQP4LR45XFC MPCG1040LR45	10mmx10mm
1	Q2		N-Channel Power MOSFET	IR	IRF7821	PWRPAKSO8
2	Q3, Q9		N-Channel Power MOSFET	IR	IRF7832	PWRPAKSO8
1	R10	715	Thick Film Chip Resistor, 1%	GENERIC	H2511-07150-1/16W1	SM0603
1	R11	1.33k	Thick Film Chip Resistor, 1%	GENERIC	H2511-01331-1/16W1	SM0603
1	R16	147k	Thick Film Chip Resistor, 1%	GENERIC	H2511-01473-1/16W1	SM0603
2	R17, R18	10	Thick Film Chip Resistor, 1%	GENERIC	H2511-00100-1/16W1	SM0603
2	R19, R23	1.91k	Thick Film Chip Resistor, 1%	GENERIC	H2511-01911-1/16W1	SM0603
3	R20, R40, R56	0	Thick Film Chip Resistor, 1%	GENERIC	H2511-00R00-1/16W1	SM0603
1	R30	909	Thick Film Chip Resistor, 1%	GENERIC	H2511-09090-1/16W1	SM0603
1	R37	1	Thick Film Chip Resistor, 1%	GENERIC	H2511-01R00-1/16W1	SM0603
1	R38	11k	Thick Film Chip Resistor, 1%	GENERIC	H2511-01102-1/16W1	SM0603
1	R41	2.61k	Thick Film Chip Resistor, 1%	GENERIC	H2511-02611-1/16W1	SM0603
1	R42	10k NTC	Thermistor, 10k NTC	PANASONIC	ERT-J1VR103J	SM0603
1	R50	7.68k	Thick Film Chip Resistor, 1%	GENERIC	H2511-07681-1/16W1	SM0603

CPU Application Reference Design Bill of Materials (Continued)

QTY	REFERENCE	VALUE	DESCRIPTION	MANUFACTURER	PART NUMBER	PACKAGE
1	R6	9.09k	Thick Film Chip Resistor, 1%	GENERIC	H2511-09091-1/16W1	SM0603
1	R63	1.82k	Thick Film Chip Resistor, 1%	GENERIC	H2511-01821-1/16W1	SM0805
1	R7	226k	Thick Film Chip Resistor, 1%	GENERIC	H2511-02263-1/16W1	SM0603
0	R109, R110, R4, R8, R9	DNP				
1	U6		IMVP-6.5 PWM Controller	INTERSIL	ISL62881CHRTZ	QFN-28

GPU Application Reference Design Bill of Materials

QTY	REFERENCE	VALUE	DESCRIPTION	MANUFACTURER	PART NUMBER	PACKAGE
1	C11	390pF	Multilayer Cap, 16V, 10%	GENERIC	H1045-00391-16V10	SM0603
1	C12	330pF	Multilayer Cap, 16V, 10%	GENERIC	H1045-00331-16V10	SM0603
1	C13	1000pF	Multilayer Cap, 16V, 10%	GENERIC	H1045-00102-16V10	SM0603
2	C16, C22	1 μ F	Multilayer Cap, 16V, 20%	GENERIC	H1045-00105-16V20	SM0603
1	C18	0.27 μ F	Multilayer Cap, 16V, 10%	GENERIC	H1045-00274-16V10	SM0603
1	C20	0.1 μ F	Multilayer Cap, 16V, 10%	GENERIC	H1045-00104-16V10	SM0603
2	C17, C30	0.22 μ F	Multilayer Cap, 25V, 10%	GENERIC	H1045-00224-25V10	SM0603
1	C21	0.047 μ F	Multilayer Cap, 16V, 10%	GENERIC	H1045-00473-16V10	SM0603
1	C24	56 μ F	Radial SP Series Cap, 25V, 20%	SANYO	25SP56M	CASE-CC
2	C27, C33	10 μ F	Multilayer Cap, 25V, 20%	GENERIC	H1065-00106-25V20	SM1206
1	C3	390pF	Multilayer Cap, 16V, 10%	GENERIC	H1045-00391-16V10	SM0603
1	C39, C52	220 μ F	SPCAP, 2V, 7M Ω	PANASONIC	EEXSX0D221E7	
1	C4	1000pF	Multilayer Cap, 16V, 10%	GENERIC	H1045-00102-16V10	SM0603
2	C40, C41	22 μ F	Multilayer Cap, 6.3V, 20%	TAIYO MURATA Kyocera TDK	JMK212BJ226MG-T GRM21BC80J226M CM21X5R226M04AT C2012X5R0J226MT009N	SM0805
2	C54, C55	10 μ F	Multilayer Cap, 6.3V, 20%	TAIYO MURATA Kyocera TDK	JMK212BJ106MG-T GRM21BR60J106ME19 CM21X5R106M06AT C2012X5R0J106MT009N	SM0805
1	C6	47pF	Multilayer Cap, 16V, 10%	GENERIC	H1045-00470-16V10	SM0603
1	C82	0.033 μ F	Multilayer Cap, 16V, 10%	GENERIC	H1045-00333-16V10	SM0603
0	C56, C59- C61, C81, C83	DNP				
1	L1	0.56 μ H	Inductor, Inductance 20%, DCR 7%	PANASONIC NEC-TOKIN	ETQP4LR56AFC MPCG1040LR56	10mmx10mm
1	Q2		N-Channel Power MOSFET	IR	IRF7821	PWRPAKS08
1	Q3		N-Channel Power MOSFET	IR	IRF7832	PWRPAKS08
1	R10	2.37k	Thick Film Chip Resistor, 1%	GENERIC	H2511-02371-1/16W1	SM0603
1	R11	3.48k	Thick Film Chip Resistor, 1%	GENERIC	H2511-03481-1/16W1	SM0603

GPU Application Reference Design Bill of Materials (Continued)

QTY	REFERENCE	VALUE	DESCRIPTION	MANUFACTURER	PART NUMBER	PACKAGE
1	R16	47.5k	Thick Film Chip Resistor, 1%	GENERIC	H2511-04752-1/16W1	SM0603
2	R17, R18	10	Thick Film Chip Resistor, 1%	GENERIC	H2511-00100-1/16W1	SM0603
1	R19	1.91k	Thick Film Chip Resistor, 1%	GENERIC	H2511-01911-1/16W1	SM0603
3	R20, R40, R56	0	Thick Film Chip Resistor, 1%	GENERIC	H2511-00R00-1/16W1	SM0603
1	R30	1.07k	Thick Film Chip Resistor, 1%	GENERIC	H2511-01071-1/16W1	SM0603
1	R37	1	Thick Film Chip Resistor, 1%	GENERIC	H2511-01R00-1/16W1	SM0603
1	R38	11k	Thick Film Chip Resistor, 1%	GENERIC	H2511-01102-1/16W1	SM0603
1	R41	2.61k	Thick Film Chip Resistor, 1%	GENERIC	H2511-02611-1/16W1	SM0603
1	R42	10k NTC	Thermistor, 10k NTC	PANASONIC	ERT-J1VR103J	SM0603
1	R50	7.15k	Thick Film Chip Resistor, 1%	GENERIC	H2511-07151-1/16W1	SM0603
1	R6	8.66k	Thick Film Chip Resistor, 1%	GENERIC	H2511-08661-1/16W1	SM0603
1	R63	3.65k	Thick Film Chip Resistor, 1%	GENERIC	H2511-03651-1/16W1	SM0805
1	R7	261k	Thick Film Chip Resistor, 1%	GENERIC	H2511-02613-1/16W1	SM0603
0	R109, R110, R4, R8, R9	DNP				
1	U6		IMVP-6.5 PWM Controller	INTERSIL	ISL62881CHRTZ	QFN-28

Typical Performance

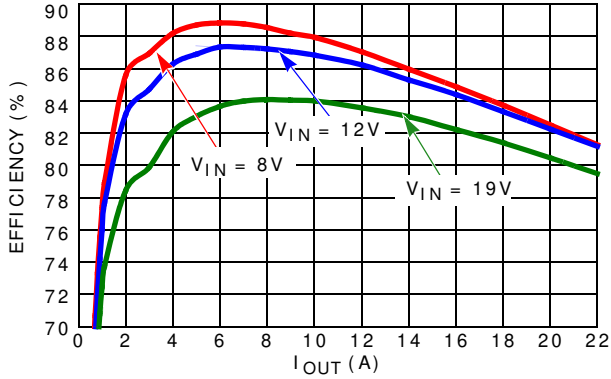

FIGURE 28. ISL62881CCPUEVAL2ZEVALUATION BOARD CCM EFFICIENCY, VID = 0.9V, VIN1 = 8V, VIN2 = 12.6V AND VIN3 = 19V

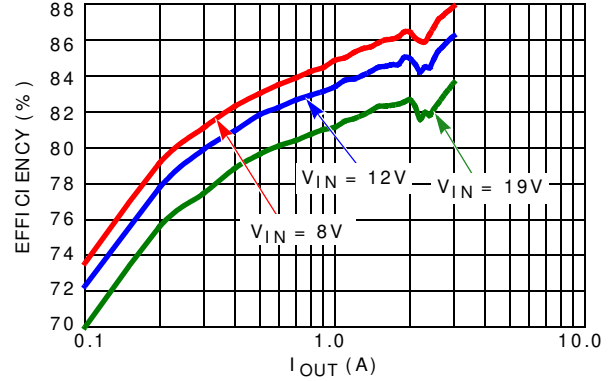

FIGURE 29. ISL62881CCPUEVAL2ZEVALUATION BOARD DE MODE EFFICIENCY, VID = 0.9V, VIN1 = 8V, VIN2 = 12.6V AND VIN3 = 19V

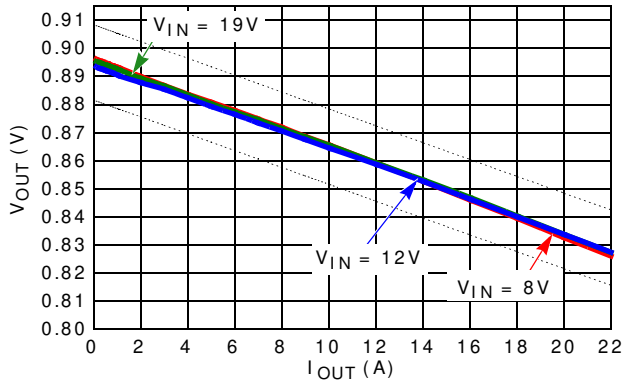

FIGURE 30. CPU APPLICATION CCM LOAD LINE, VID = 0.9V, VIN1 = 8V, VIN2 = 12.6V AND VIN3 = 19V

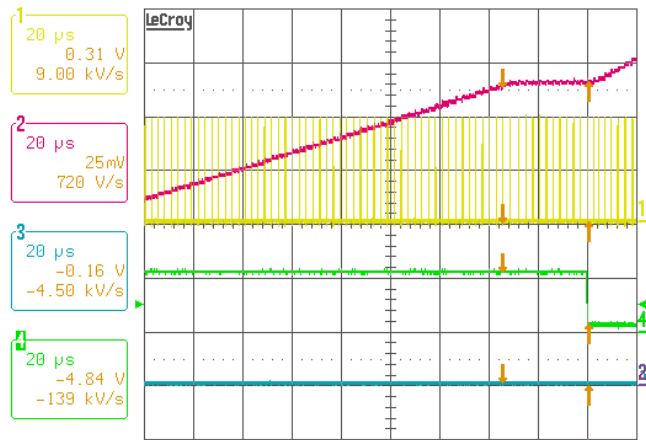

FIGURE 31. CPU MODE CLK_EN# DELAY, VIN = 19V, IO = 0A, VID = 1.2V, Ch1: PHASE1, Ch2: VO, Ch4: CLK_EN#

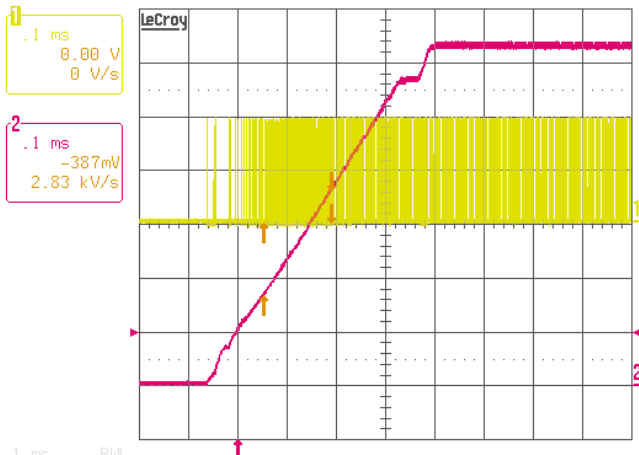

FIGURE 32. CPU MODE SOFT-START, VIN = 19V, IO = 0A, VID = 1.2V, Ch1: PHASE, Ch2: VO

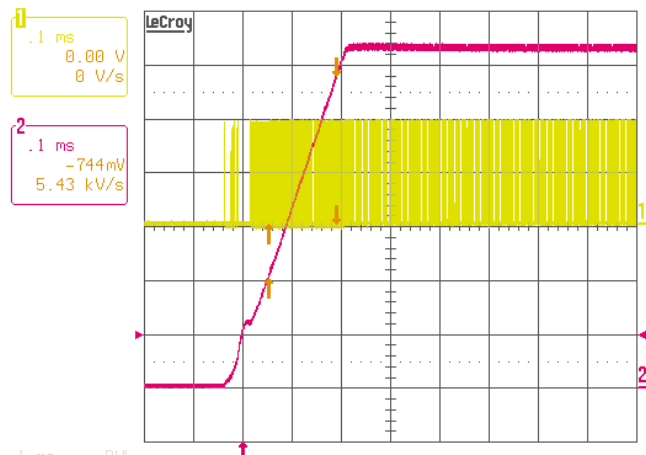

FIGURE 33. GPU MODE SOFT-START, VIN = 19V, IO = 0A, VID = 1.2V, Ch1: PHASE, Ch2: VO

Typical Performance (Continued)

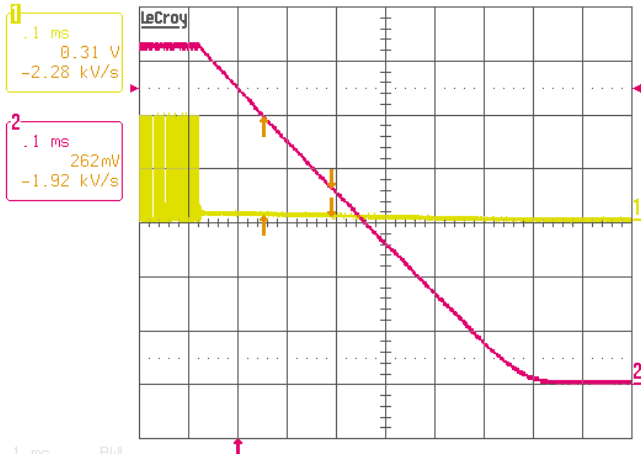

FIGURE 34. CPU MODE SHUT DOWN, $V_{IN} = 19V$, $I_O = 0A$, $V_{ID} = 1.2V$, Ch1: PHASE, Ch2: V_O

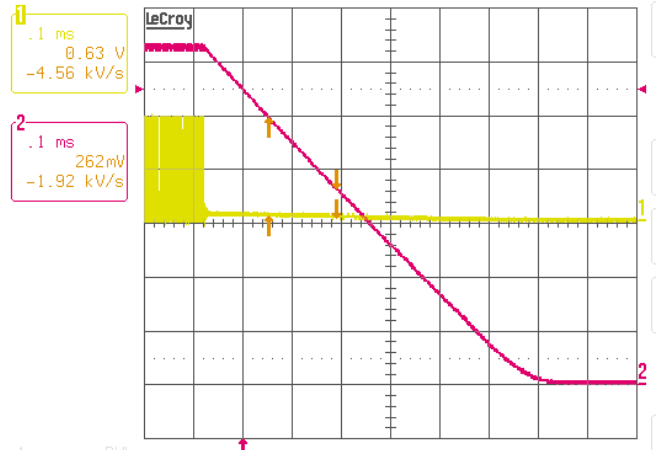

FIGURE 35. GPU MODE SHUT DOWN, $V_{IN} = 19V$, $I_O = 0A$, $V_{ID} = 1.2V$, Ch1: PHASE, Ch2: V_O

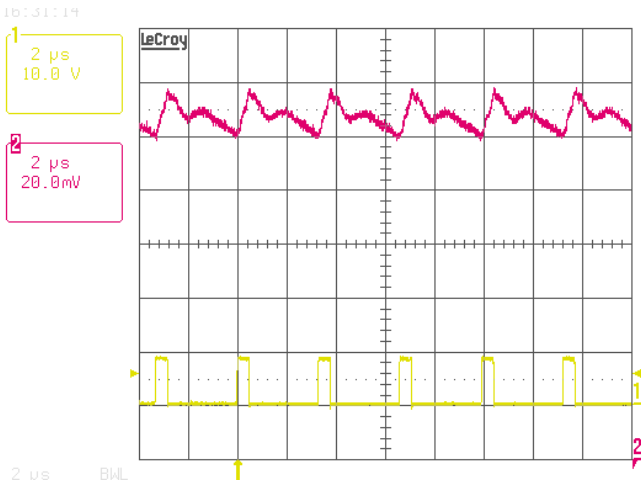

FIGURE 36. CCM STEADY STATE, CPU MODE, $V_{IN} = 8V$, $I_O = 1A$, $V_{ID} = 1.2375V$, Ch1: PHASE, Ch2: V_O

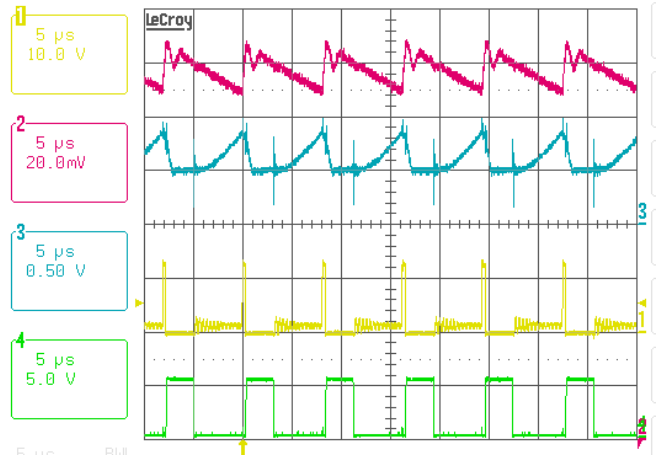

FIGURE 37. DCM STEADY STATE, CPU MODE, $V_{IN} = 12V$, $I_O = 1A$, $V_{ID} = 1.075V$, Ch1: PHASE1, Ch2: V_O , Ch3: COMP, Ch4: LGATE

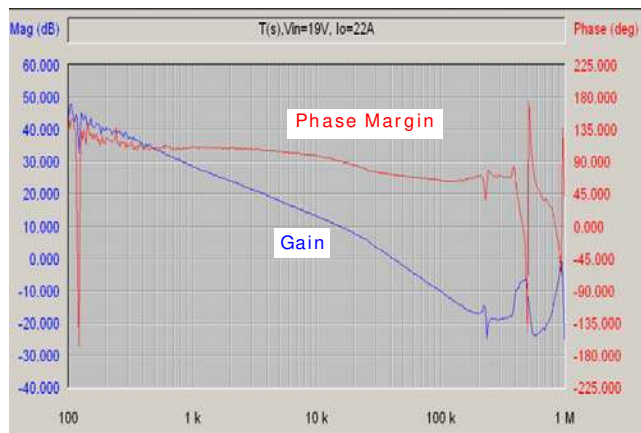

FIGURE 38. GPU MODE REFERENCE DESIGN LOOP GAIN T2(s) MEASUREMENT RESULT

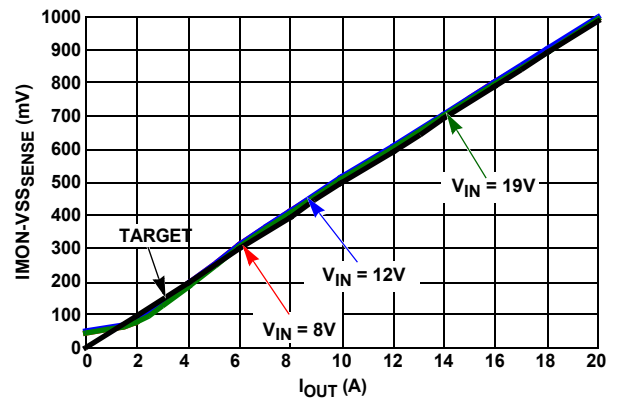

FIGURE 39. IMON, $V_{ID} = 1.2375$

Typical Performance (Continued)

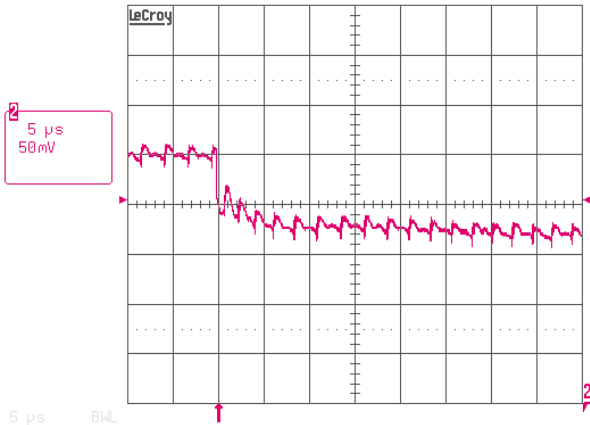

FIGURE 40. LOAD TRANSIENT RESPONSE WITH OVERSHOOT REDUCTION FUNCTION DISABLED, GPU MODE, $V_{IN} = 12V$, $V_{ID} = 0.9V$, $I_O = 12A/22A$, $di/dt = \text{“FASTEST”}$

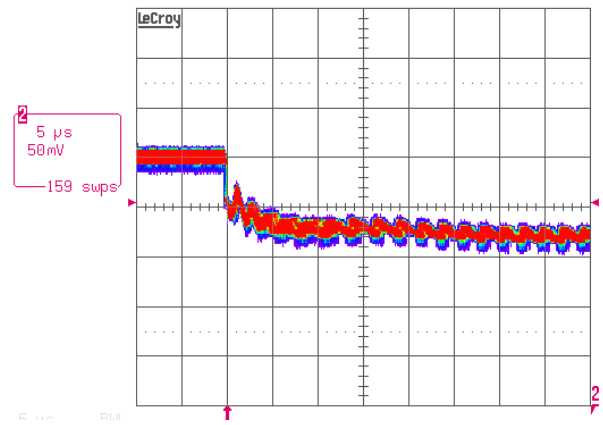

FIGURE 41. LOAD TRANSIENT RESPONSE WITH OVERSHOOT REDUCTION FUNCTION DISABLED, GPU MODE, $V_{IN} = 12V$, $V_{ID} = 0.9V$, $I_O = 12A/22A$, $di/dt = \text{“FASTEST”}$

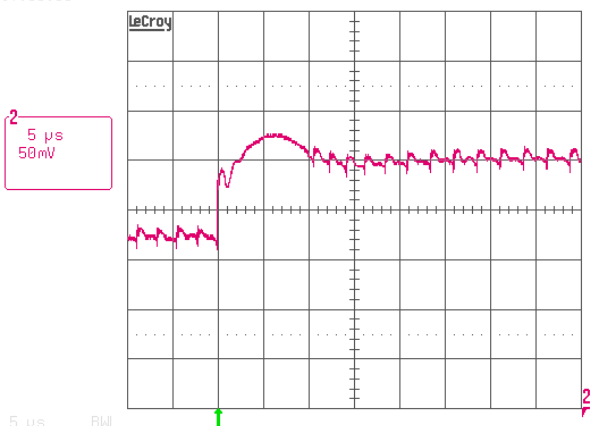

FIGURE 42. LOAD TRANSIENT RESPONSE WITH OVERSHOOT REDUCTION FUNCTION DISABLED, GPU MODE, $V_{IN} = 12V$, $V_{ID} = 0.9V$, $I_O = 12A/22A$, $di/dt = \text{“FASTEST”}$

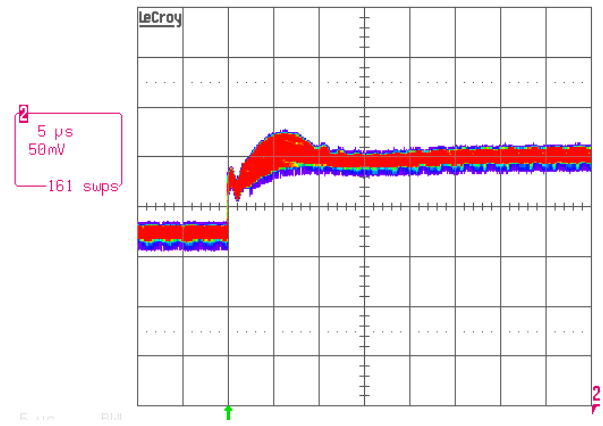

FIGURE 43. LOAD TRANSIENT RESPONSE WITH OVERSHOOT REDUCTION FUNCTION DISABLED, GPU MODE, $V_{IN} = 12V$, $V_{ID} = 0.9V$, $I_O = 12A/22A$, $di/dt = \text{“FASTEST”}$

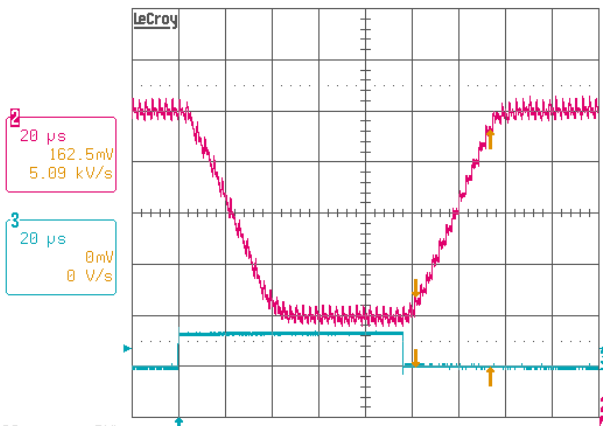

FIGURE 44. CPU MODE VID TRANSITION, $DPRSLPVR = 0$, $I_O = 2A$, $V_{ID} = 1.2375V/1.0375V$, Ch2: V_O , Ch3: VID4

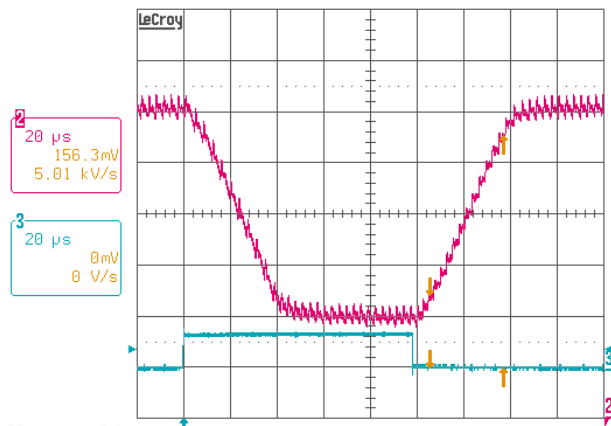

FIGURE 45. GPU MODE VID TRANSITION, $DPRSLPVR = 0$, $I_O = 2A$, $V_{ID} = 1.2375V/1.0375V$, Ch2: V_O , Ch3: VID4

Typical Performance (Continued)

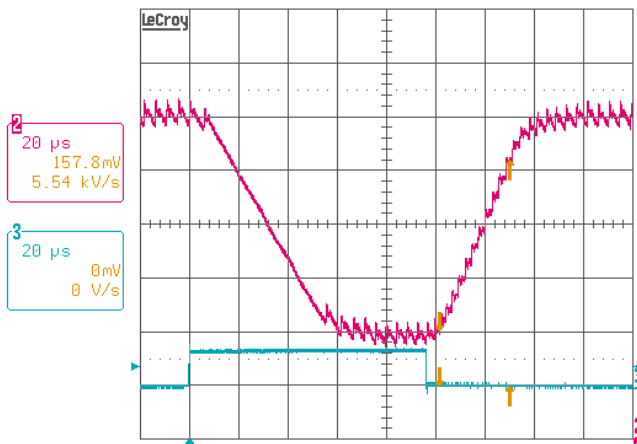

FIGURE 46. CPU MODE VID TRANSITION,
DPRSLPVR = 1, $I_O = 2A$,
VID = 1.2375V/ 1.0375V, Ch2: V_O ,
Ch3: VID4

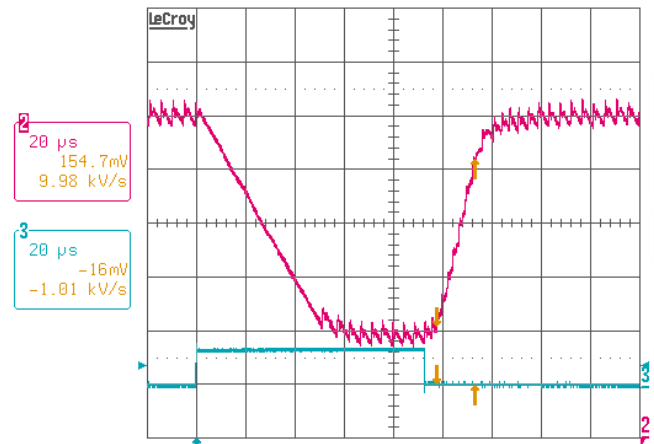

FIGURE 47. GPU MODE VID TRANSITION,
DPRSLPVR = 1, $I_O = 2A$,
VID = 1.2375V/ 1.0375V, Ch2: V_O ,
Ch3: VID4

Revision History

The revision history provided is for informational purposes only and is believed to be accurate, but not warranted. Please go to web to make sure you have the latest Rev.

DATE	REVISION	CHANGE
3/8/10	FN7596.0	Initial Release.

Products

Intersil Corporation is a leader in the design and manufacture of high-performance analog semiconductors. The Company's products address some of the industry's fastest growing markets, such as, flat panel displays, cell phones, handheld products, and notebooks. Intersil's product families address power management and analog signal processing functions. Go to www.intersil.com/products for a complete list of Intersil product families.

* For a complete listing of Applications, Related Documentation and Related Parts, please see the respective device information page on intersil.com: [ISL62881C](http://www.intersil.com/ISL62881C), [ISL62881D](http://www.intersil.com/ISL62881D)

To report errors or suggestions for this datasheet, please go to www.intersil.com/askourstaff

FiTs are available from our website at <http://rel.intersil.com/reports/search.php>

© Copyright Intersil Americas LLC 2010. All Rights Reserved.

All trademarks and registered trademarks are the property of their respective owners.

For additional products, see www.intersil.com/en/products.html

Intersil products are manufactured, assembled and tested utilizing ISO9001 quality systems as noted in the quality certifications found at www.intersil.com/en/support/qualandreliability.html

Intersil products are sold by description only. Intersil may modify the circuit design and/or specifications of products at any time without notice, provided that such modification does not, in Intersil's sole judgment, affect the form, fit or function of the product. Accordingly, the reader is cautioned to verify that datasheets are current before placing orders. Information furnished by Intersil is believed to be accurate and reliable. However, no responsibility is assumed by Intersil or its subsidiaries for its use; nor for any infringements of patents or other rights of third parties which may result from its use. No license is granted by implication or otherwise under any patent or patent rights of Intersil or its subsidiaries.

For information regarding Intersil Corporation and its products, see www.intersil.com

Package Outline Drawing

L28.4x4

28 LEAD THIN QUAD FLAT NO-LEAD PLASTIC PACKAGE

Rev 0, 9/06

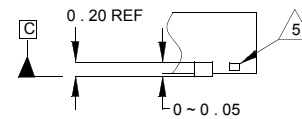
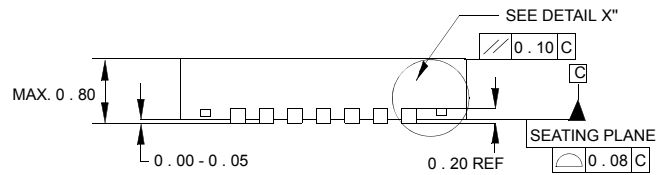
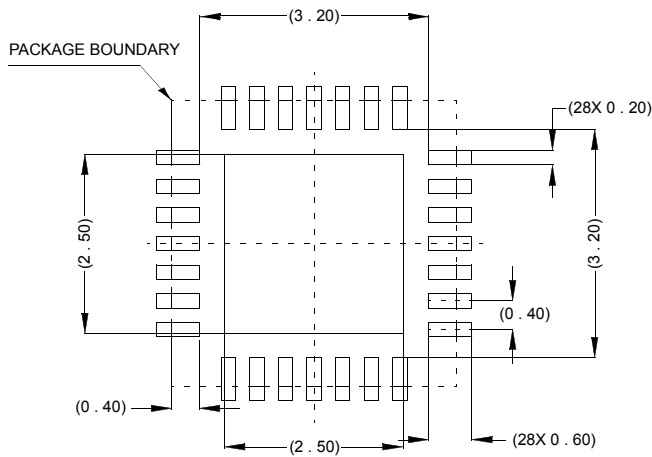
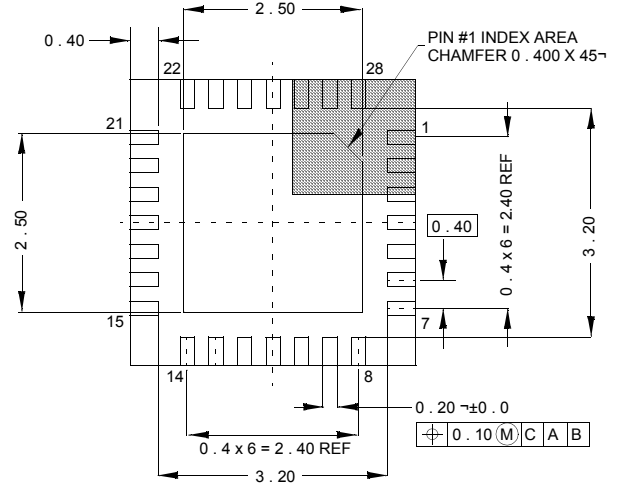
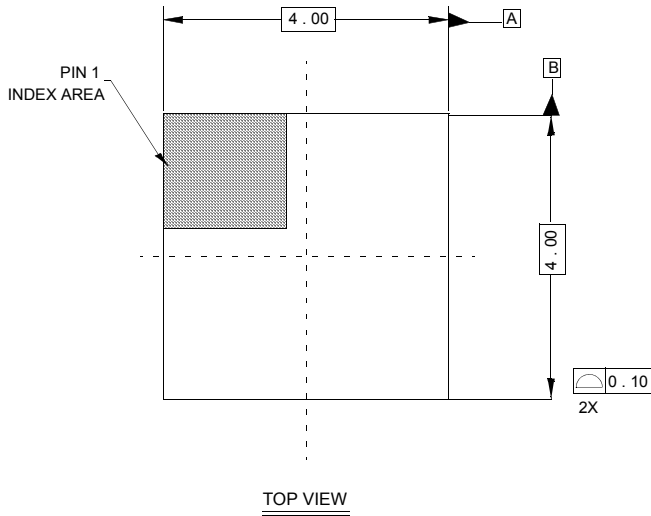

NOTES:

1. Controlling dimensions are in mm.
Dimensions in () for reference only.
2. Unless otherwise specified, tolerance : Decimal ± 0.05
Angular $\pm 2^\circ$
3. Dimensioning and tolerancing conform to AMSE Y14.5M-1994.
4. Bottom side Pin#1 ID is diepad chamfer as shown.
5. Tiebar shown (if present) is a non-functional feature.

Package Outline Drawing

L32.5x5E

32 LEAD THIN QUAD FLAT NO-LEAD PLASTIC PACKAGE

Rev 0, 03/09

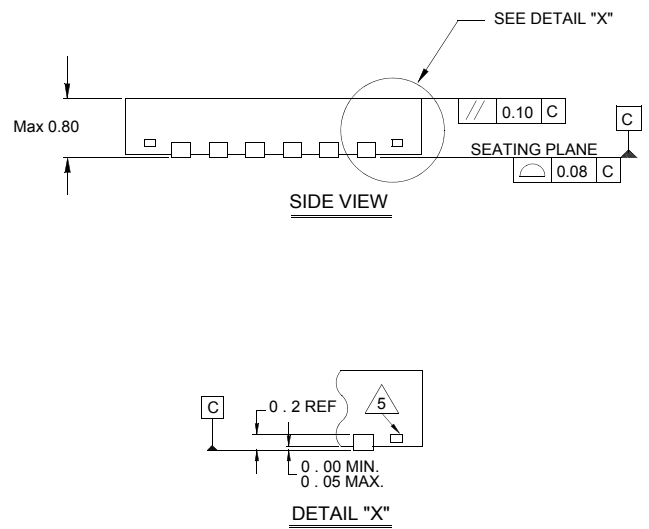
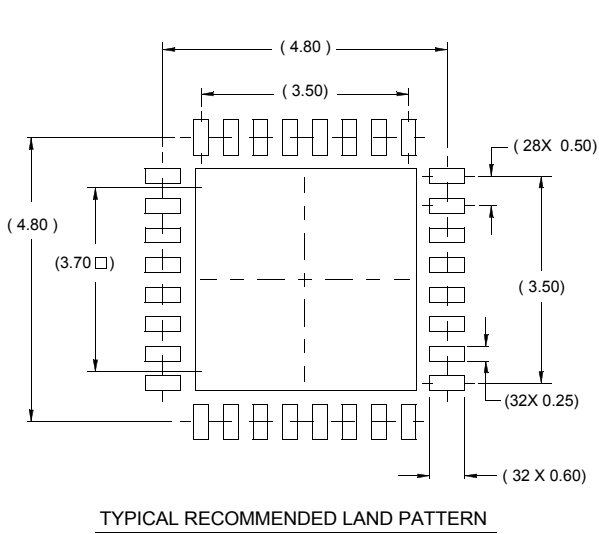
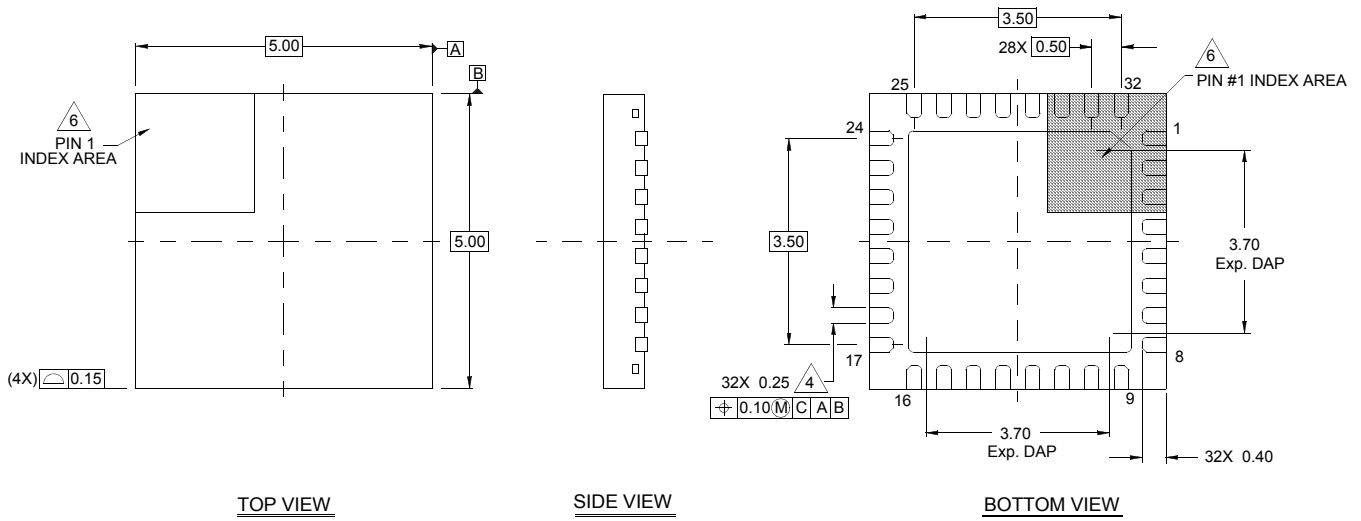

NOTES:

1. Dimensions are in millimeters.
Dimensions in () for Reference Only.
2. Dimensioning and tolerancing conform to AMSE Y14.5m-1994.
3. Unless otherwise specified, tolerance : Decimal ± 0.0
4. Dimension b applies to the metallized terminal and is measured between 0.15mm and 0.30mm from the terminal tip.
5. Tiebar shown (if present) is a non-functional feature.
6. The configuration of the pin #1 identifier is optional, but must be located within the zone indicated. The pin #1 identifier may be either a mold or mark feature.