

# TMP103EVM

---



---



---

This user's guide describes the characteristics, operation, and use of the TMP103EVM evaluation board. It provides a detailed description of the hardware design. It discusses how to set up and configure the evaluation module (EVM) software, and reviews the hardware and various aspects of the software operation. This document also includes information regarding operating procedures and input/output connections, an electrical schematic, printed-circuit board (PCB) layout drawings, and a parts list for the TMP103EVM. Throughout this document, the terms *evaluation board*, *evaluation module*, and *EVM* are synonymous with the TMP103EVM.

## Contents

1	Overview .....	2
2	System Setup .....	3
3	Theory of Operation .....	4
4	TMP103EVM Hardware Overview.....	5
5	TMP103EVM Software Setup .....	8
6	TMP103EVM Software Overview .....	12
7	TMP103EVM Documentation.....	18
8	Bill of Materials .....	20

## List of Figures

1	Typical Hardware Included With the TMP103EVM Kit.....	2
2	TMP103EVM Hardware Setup.....	3
3	TMP103 Test Board Block Diagram.....	4
4	SM-USB-DIG Platform Block Diagram.....	5
5	Connecting the USB Cable to the SM-USB-DIG Platform .....	6
6	SM-USB-DIG Platform Driver Installation Confirmation .....	6
7	10-Pin Ribbon Cable Extender.....	7
8	TMP103EVM Welcome Window.....	8
9	TMP103EVM License Agreements.....	9
10	NI License Agreements.....	10
11	TMP103EVM Installation Directory .....	10
12	Select Components Installation .....	11
13	TMP103EVM Software <i>About</i> Button.....	11
14	TMP103EVM Software Interface: Proper Operation.....	12
15	Communication Error With USB DIG Platform .....	12
16	TMP103EVM Software: Reading from Registers .....	13
17	TMP103EVM Software: Writing to Registers .....	14
18	Conversion Time Selection Dialog .....	14
19	Max Temp Flag Trigger .....	15
20	TMP103EVM Software: Register Tab .....	16
21	TMP103EVM Software: Test Procedure .....	17
22	TMP103EVM Schematic .....	18
23	TMP103EVM Component Layout .....	19

## Trademarks

Microsoft, Windows are registered trademarks of Microsoft Corporation.  
 I<sup>2</sup>C is a trademark of NXP Semiconductors.  
 All other trademarks are the property of their respective owners.

## 1 Overview

The **TMP103** is a digital output temperature sensor capable of reading temperatures to 1°C resolution. The TMP103 uses a two-wire I<sup>2</sup>C™ and SMBus interface that supports global commands. These global commands allow the user to communicate with up to eight TMP103 devices on the bus without having to send individual addresses. The TMP103 is ideal for environments with constrained space or power-sensitive applications. The TMP103 is also specified to operate between –40°C and +125°C.

### 1.1 TMP103EVM Kit Contents

**Figure 1** illustrates the typical hardware included the TMP103EVM. **Table 1** details the contents of the TMP103EVM kit, Contact the [Texas Instruments Product Information Center \(PIC\)](#) nearest you if any component is missing. TI highly recommends that you check the TI web site at <http://www.ti.com> to verify that you have the latest versions of the related software.



**Figure 1. Typical Hardware Included With the TMP103EVM Kit**

**Table 1. TMP103EVM Kit Contents**

Item	Quantity
TMP103 PCB Test Board	1
SM-USB-DIG Platform PCB	1
USB Cable Extender	1
10-pin Connector Ribbon Cable Extender	1

## 1.2 If You Need Assistance

If you have questions about the TMP103EVM, contact the Temperature Sensing Applications Team by posting on E2E forum here: [https://e2e.ti.com/support/sensor/temperature\\_sensors/](https://e2e.ti.com/support/sensor/temperature_sensors/).

## 1.3 Related Documentation

The following documents provide information regarding Texas Instruments integrated circuits used in the assembly of the TMP103EVM. This user's guide is available from the TI web site under literature number **SBOU099**. Any letter appended to the literature number corresponds to the document revision that is current at the time of the writing of this document. Newer revisions may be available from the TI web site at <http://www.ti.com>, or call the Texas Instruments Literature Response Center at (800) 477-8924 or the Product Information Center at (972) 644-5580. When ordering, identify the document by both title and literature number.

**Table 2. Related Documentation**

Document	Literature Number
TMP103 Product Data Sheet	<a href="#">SBOS545</a>
SM-USB-DIG Platform User's Guide	<a href="#">SBOU098</a>

## 1.4 FCC Warning

This equipment is intended for use in a laboratory test environment only. It generates, uses, and can radiate radio frequency energy and has not been tested for compliance with the limits of computing devices pursuant to subpart J of part 15 of FCC rules, which are designed to provide reasonable protection against radio frequency interference. Operation of this equipment in other environments may cause interference with radio communications, in which case the user is required to take whatever measures may be required to correct this interference at their own expense.

## 2 System Setup

The TMP103EVM hardware consists of the SM-USB-DIG Platform and the TMP103EVM; these units are easily connected through a 10-pin, board-to-board connector that should be attached to the SM-USB-DIG and TMP103EVM PCBs. Once these two boards are connected, simply plug the USB device from the SM-DIG into the computer as shown in [Figure 2](#).

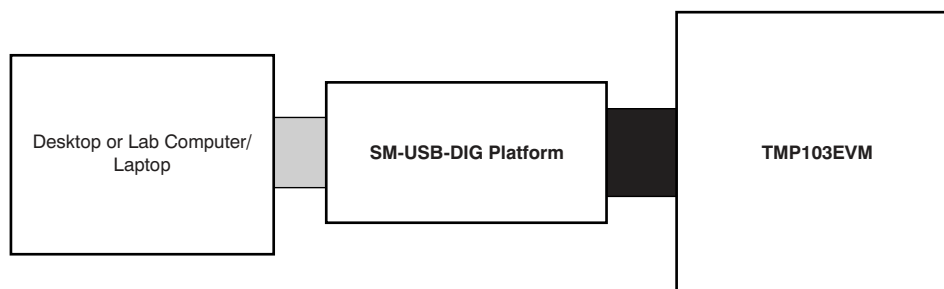

**Figure 2. TMP103EVM Hardware Setup**

### 3 Theory of Operation

The TMP103EVM is very modest in its design, and only requires the two-wire I<sup>2</sup>C lines (SDA and SCLK) and V<sub>DUT</sub>/GND to supply a constant 3.3 V and power return, as shown in Figure 3. The TMP103EVM also has several test points to monitor these signal lines, and ground, in case users may want to use their own signals or verify I<sup>2</sup>C communications.

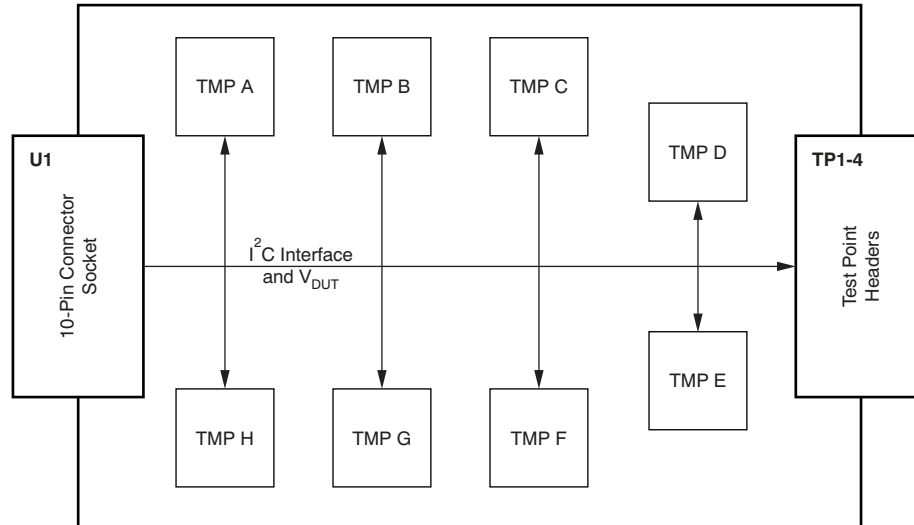

**Figure 3. TMP103 Test Board Block Diagram**

#### 3.1 Signal Definitions of H1 (10-Pin Male Connector Socket)

Table 3 shows the pinout for the 10-pin connector socket used to communicate between the TMP103EVM and the SM-USB-DIG. It should be noted that the TMP103EVM only uses the necessary I<sup>2</sup>C communication lines (Pins 1 and 3) and the V<sub>DUT</sub> and GND (Pins 6 and 8) pins to issue commands to the TMP103 sensors.

**Table 3. Pin Connector**

Pin on U1	Signal	Description
1	I2C_SCL	I <sup>2</sup> C clock signal (SCL)
2	CTRL/MEAS4	GPIO: Control output or measure input
3	I2C_SDA1	I <sup>2</sup> C data signal (SDA)
4	CTRL/MEAS5	GPIO: Control output or measure input
5	SPI_DOUT1	SPI data output (MOSI)
6	V <sub>DUT</sub>	Switchable DUT power supply: +3.3 V, +5 V, Hi-Z (disconnected). <sup>(1)</sup>
7	SPI_CLK	SPI clock signal (SCLK)
8	GND	Power return (GND)
9	SPI_CS1	SPI chip select Signal ( $\overline{CS}$ )
10	SPI_DIN1	SPI data input (MISO)

<sup>(1)</sup> When V<sub>DUT</sub> is Hi-Z, all digital I/Os are Hi-Z as well.

### 3.2 Theory of Operation for the SM-USB-DIG Platform

Figure 4 shows the block diagram for the SM-USB-DIG Platform. This platform is a general-purpose data acquisition system that is used on several different Texas Instruments' evaluation modules. The details of its operation are included in a separate document, the *SM-USB-DIG Platform User's Guide* (SBOU098), available for download at [www.ti.com](http://www.ti.com)). The block diagram in Figure 4 is presented as a brief overview of the Platform.

The core of the SM-USB-DIG Platform is the TUSB3210, an 8052 microcontroller ( $\mu\text{C}$ ) that has a built-in USB interface. The microcontroller receives information from the host computer that it translates into I<sup>2</sup>C, SPI, or other digital I/O patterns. During the digital I/O transaction, the microcontroller reads the response of any device connected to the I/O interface. The response from the device is then sent back to the PC where it is interpreted by the host computer.

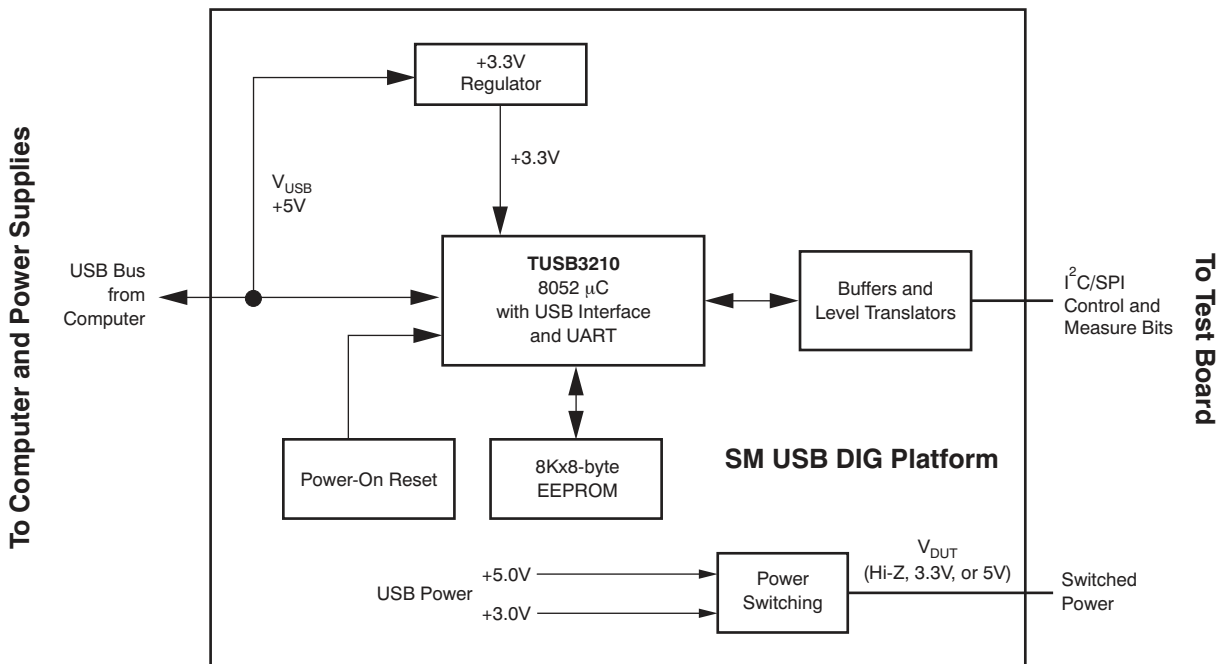

Figure 4. SM-USB-DIG Platform Block Diagram

## 4 TMP103EVM Hardware Overview

### 4.1 Electrostatic Discharge Warning

#### CAUTION

Many of the components on the TMP103EVM are susceptible to damage by electrostatic discharge (ESD). Customers are advised to observe proper ESD handling precautions when unpacking and handling the EVM, including the use of a grounded wrist strap at an approved ESD workstation.

### 4.2 Connecting the Hardware

To connect the TMP103 Test Board and the SM-USB-DIG Platform together, gently slide the male and female ends of the 10-pin connectors together. Make sure that the two connectors are completely pushed together; loose connections may cause intermittent operation.

### 4.3 Connecting the USB Cable to the SM-USB-DIG Platform

Figure 5 depicts the USB cable connected to the SM-USB-DIG Platform. Be careful when inserting the connectors.



**Figure 5. Connecting the USB Cable to the SM-USB-DIG Platform**

Figure 6 shows the typical system response when the SM-USB-DIG Platform board connects to a PC USB port for the first time. Typically, the computer will respond with a *Found New Hardware, USB Device* pop-up dialog. The pop-up window then generally changes to *Found New Hardware, USB Human Interface Device*. This pop-up screen indicates that the device is ready to be used. The SM-USB-DIG Platform uses the human interface device drivers that are part of the Microsoft® Windows® operating system.

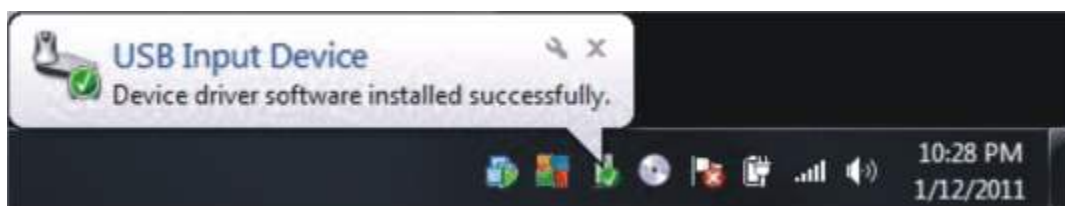

**Figure 6. SM-USB-DIG Platform Driver Installation Confirmation**

## 4.4 TMP103EVM Features

This section describes some of the hardware features present on the TMP103 test board.

### 4.4.1 Populating 0-Ω Resistors

The TMP103 test board contains 0-Ω resistors (R1 to R16) that connect the individual TMP103 sensors to the I<sup>2</sup>C bus lines. When these resistors are populated, they become available for communication in general calls. If the 0-Ω resistors are not populated for certain TMP103 devices on the board, they are not able to communicate with the software or receive any external I<sup>2</sup>C commands. Leaving the resistors unpopulated could be useful if one of the TMP103 units becomes damaged or fewer than eight TMP103s are populated.

### 4.4.2 Multiple TMP103 Sensors

The TMP103EVM board was designed to take advantage of the I<sup>2</sup>C general call described in the TMP103 product data sheet. This feature allows the software to communicate with all the TMP103s simultaneously without requiring individual commands with separate pointer addresses to the sensors. The maximum number of sensors on the TMP103 test board is eight; all devices have separate hardware address, so a board of eight populated TMP103 devices requires eight different part types. For assignment of the pointer addresses and a more detailed description, consult the [TMP103 Low-Power, Digital Temperature Sensor With Two-Wire Interface in WCSP](#) data sheet (SBOS545).

### 4.4.3 I<sup>2</sup>C Test Points

I<sup>2</sup>C test points are included on the TMP103 test board for user convenience. These test points can be used to monitor the two-wire lines of the I<sup>2</sup>C interface or to run the TMP103 test board externally without the use of the SM-USB-DIG.

### 4.4.4 Optional 10-Pin Connector Ribbon Extender

The TMP103EVM kit ships with an optional ribbon cable to extend the connection between the SM-USB-DIG and the TMP103EVM PCB. This cable can be useful if high temperature tests must be run on the test board, because the SM-USB-DIG platform is not rated for high temperatures. To connect the ribbon cable, attach the cable to the EVM and SM-USB-DIG Platform board as shown in [Figure 7](#).

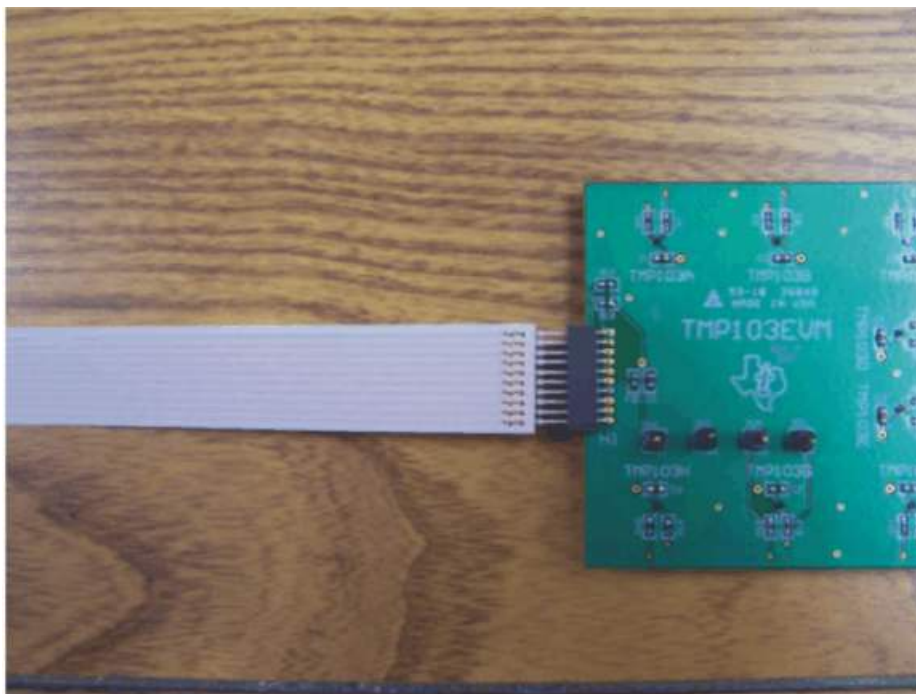

**Figure 7. 10-Pin Ribbon Cable Extender**

## 5 TMP103EVM Software Setup

This section discusses how to install the TMP103EVM software.

### 5.1 Operating Systems Compatibility

The TMP103EVM software has been tested on the Microsoft Windows 7. The software should also function on other Windows operating systems such as Windows 10.

### 5.2 TMP103EVM Software Installation

The EVM software is tested on the Microsoft Windows 7 and 10 operating system (OS). The software also functions on other Windows operating systems. The EVM software is available through the EVM product folder on the TI website. To download the software to your system, simply follows the instructions below.

1. Go to the TMP103EVM web page on the TI website: <http://www.ti.com/tool/TMP103EVM>. Scroll down to the Software section and download the latest evaluation software.
2. Unzip the downloaded file into a known directory. Once the files are extracted, navigate and run the *Setup\_TMP103EVM\_GUI.exe* file located in [Unzip location]. The EVM software installer then begins the installation process as shown in [Figure 8](#).

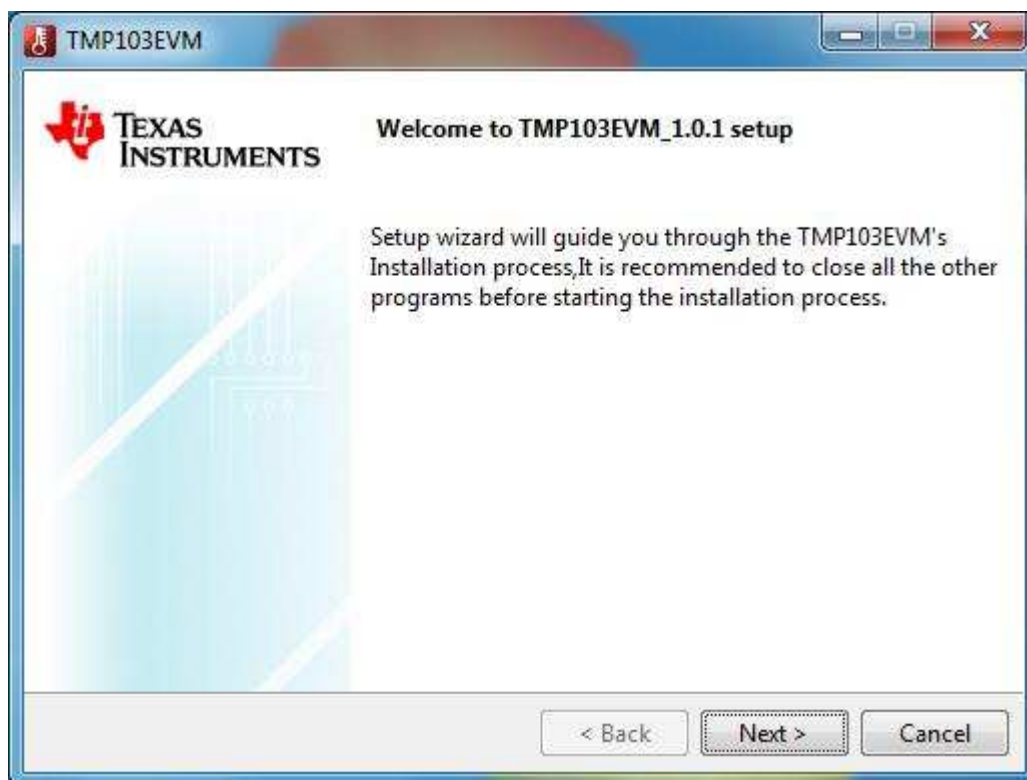

**Figure 8. TMP103EVM Welcome Window**



3. Follow the on-screen instructions by clicking the *Next* button to install the software. Following this option, two license agreements are presented as shown in [Figure 9](#) and [Figure 10](#) that must be accepted. After accepting both the Texas Instruments and National Instruments license agreements, the user is given the choice of selecting the directory to install the program; usually, TI recommends choosing the default setting stored in the *C:\Program Files\TMP103EVM* path as shown in [Figure 11](#).

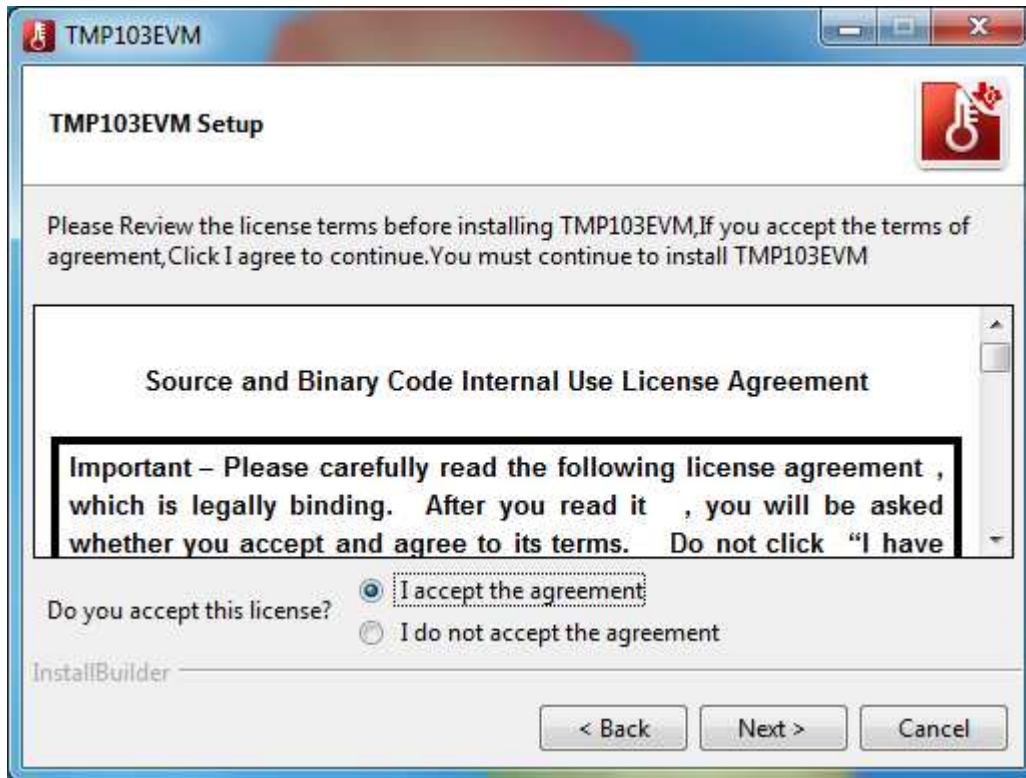

**Figure 9. TMP103EVM License Agreements**

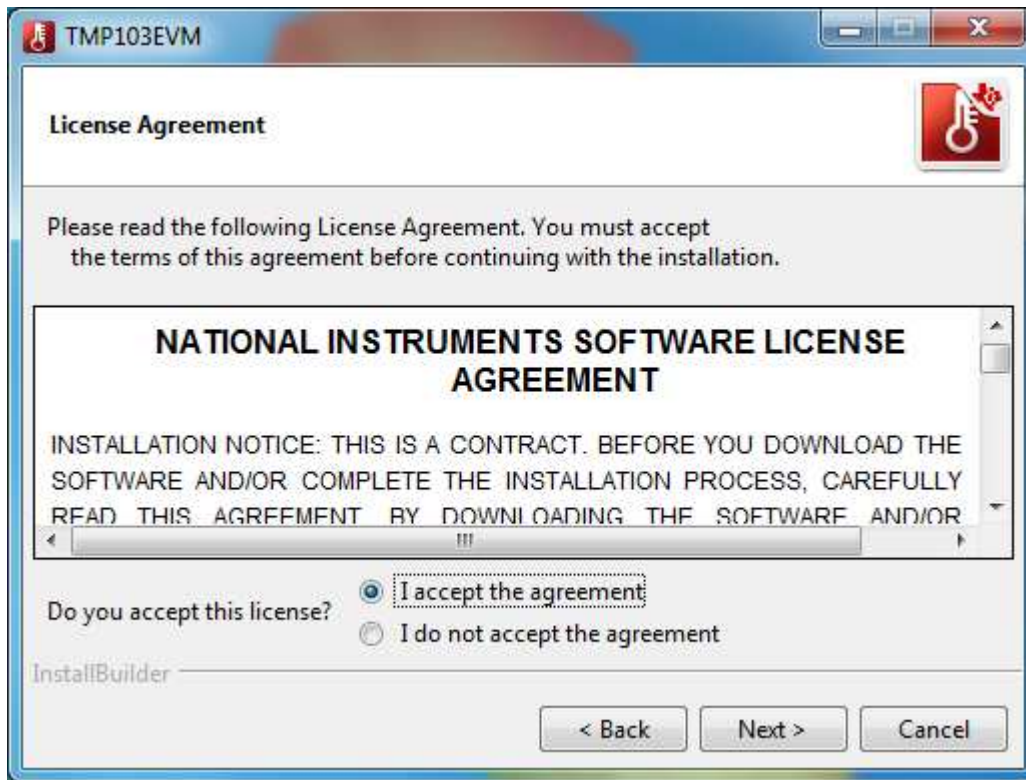

Figure 10. NI License Agreements

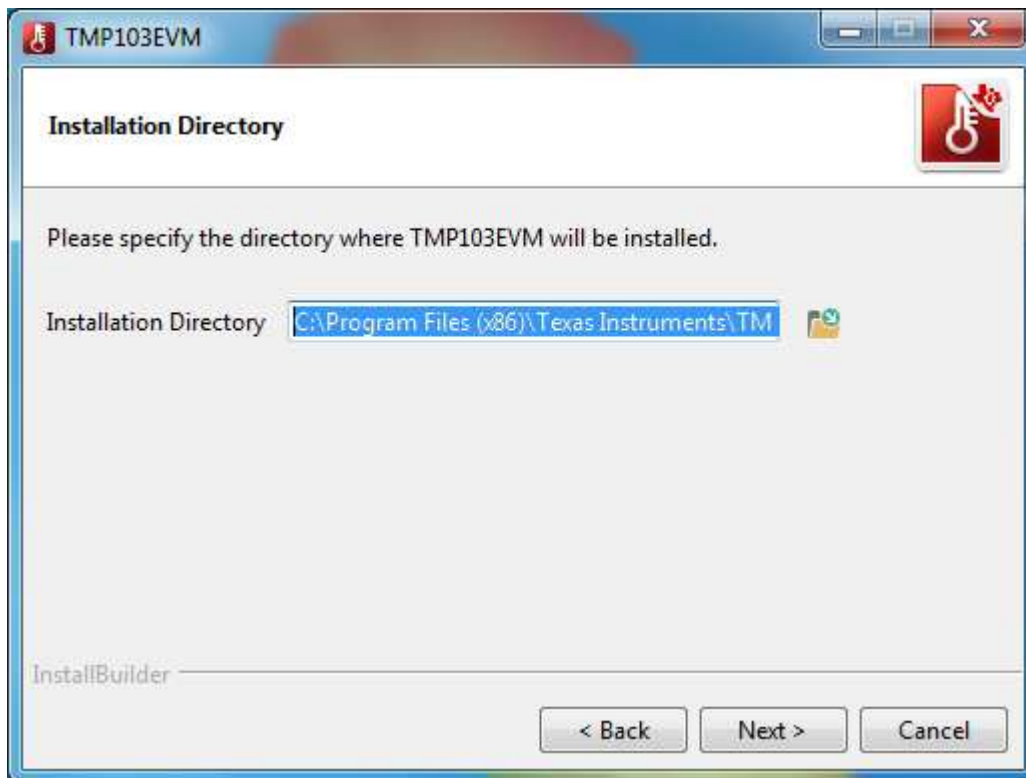

Figure 11. TMP103EVM Installation Directory

4. For first-time installation, ensure the LabVIEW Run Time Engine is listed in the following summary as shown in [Figure 12](#). TMP103EVM GUI is required LabVIEW 2016 f2 runtime engine for proper operation. Once the Next button is clicked, the progress bar opens and shows the installation of the software. It may take some time to download the LabVIEW Run Time Engine on the first installation. Users may be prompted to download the file when installing the software for the first time, especially if the LabVIEW Run Time Engine checkbox is checked.

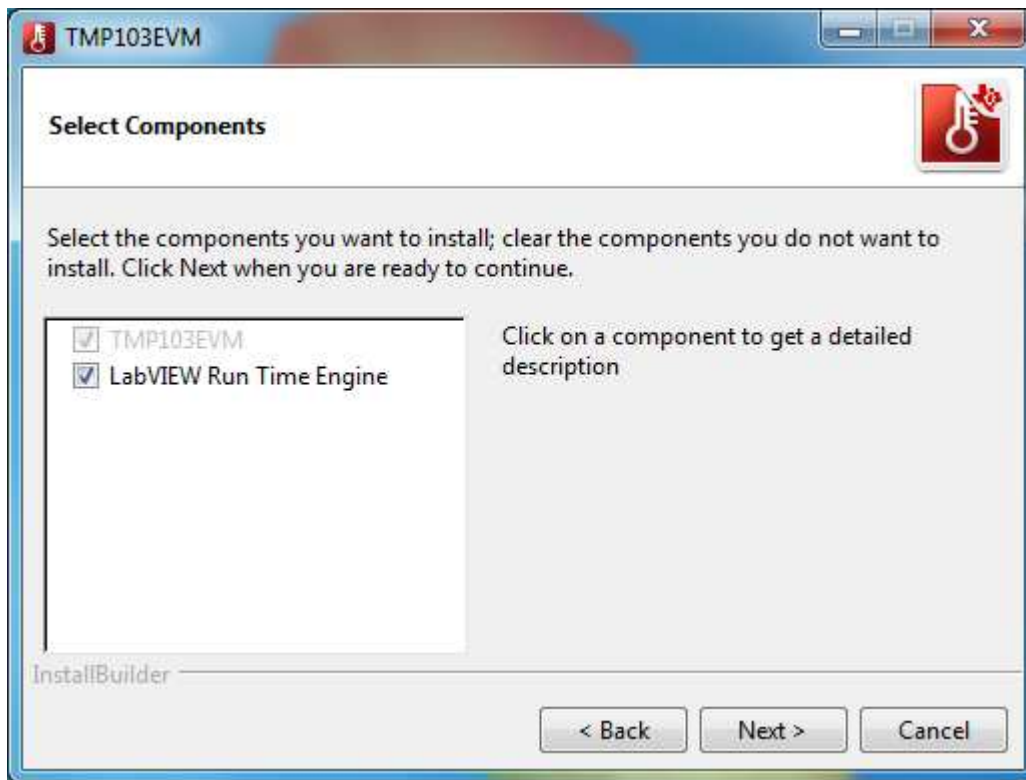

Figure 12. Select Components Installation

### 5.3 Software Description and Set-Up

The TMP103EVM software allows the user to monitor temperatures from eight separate TMP103 sensor units. [Figure 13](#) shows the screen that displays when you press the **About** button to verify that you have the latest version of the software.



Figure 13. TMP103EVM Software About Button

## 6 TMP103EVM Software Overview

This section discusses how to use the TMP103EVM software.

### 6.1 Starting the TMP103EVM Software

The TMP103EVM software can be operated through the *Start* menu in Windows. From the *Start* menu, select *All Programs*; highlight the TMP103 folder, and then select the TMP103EVM program. Figure 14 illustrates how the software should appear if the TMP103EVM is functioning properly.

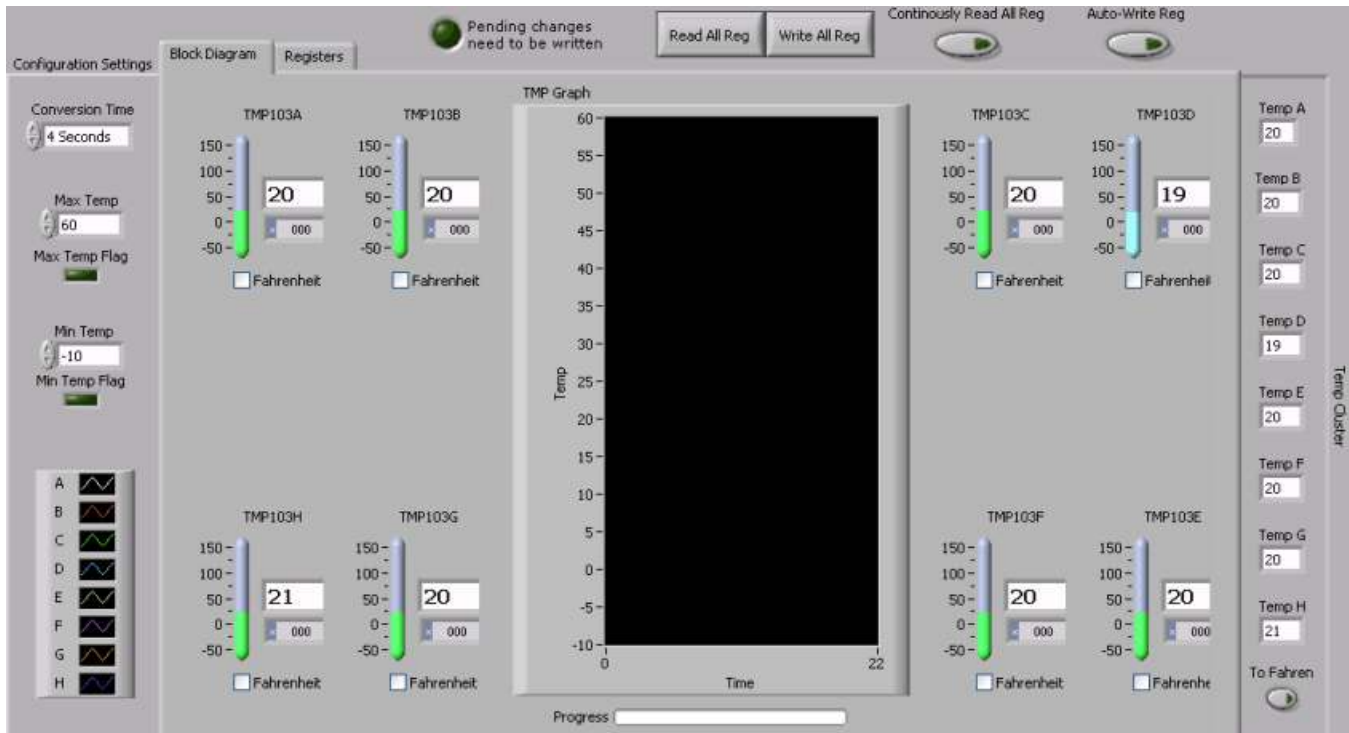

Figure 14. TMP103EVM Software Interface: Proper Operation

Figure 15 shows an error that pops up if the computer cannot communicate with the EVM. If you receive this error, first ensure that the USB cable is properly connected on both ends. Another possible source for this error is a problem with your computer USB Human Interface Device driver. Make sure that the device is recognized when the USB cable is plugged in; recognition is indicated by a Windows-generated confirmation sound.

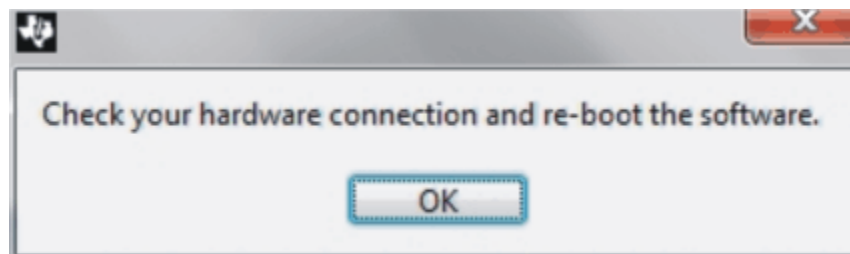

Figure 15. Communication Error With USB DIG Platform

## 6.2 Using the TMP103EVM Software

### 6.2.1 Reading from Registers

When first starting the TMP103EVM software, users are advised to confirm connections to the board by toggling the **Continuously Read All Register** button (highlighted in Figure 16). If all devices are communicating correctly, the user should be able to see temperature change over time in the TMP Graph and the individual TMP103 thermometers. A legend is provided in the Configuration Settings column on the left for the temperature graph; refer to Figure 17.



Figure 16. TMP103EVM Software: Reading from Registers

An alternative method for acquiring data is the **Read All Reg** button, also indicated in Figure 16. This button is useful while the **Auto-Write Reg** button is toggled, or if the user wants to take individual measurements on a non-standard time interval.

**NOTE:** The user cannot continuously press either the **Read All Registers** or the **Auto-Write Registers** button.

### 6.2.2 Writing to Registers

The TMP103EVM software contains two different methods for writing data: **Write All Reg** and **Auto-Write Reg**. Individually writing the registers without Auto-Write can be useful when adjusting large numbers of the configuration registers on the left. Also, if the user wishes to change some of the configuration settings on the left while continuously reading registers, he or she will be prompted with a blinking **Write All Registers** button. Until the **Write All Registers** button has been selected, the program stops polling data from the TMP103 sensors. Conversely, the **Auto-Write Registers** feature automatically makes changes to the configuration register whenever one of the configuration settings on the left changes, as indicated in Figure 17.



Figure 17. TMP103EVM Software: Writing to Registers

### 6.2.3 Conversion Time

The *Conversion Time* selection box, shown in Figure 18, is used to change the speed at which the TMP103 sensors measure the ambient temperature around them. A user may want to set the conversion speed faster if data must be gathered faster. The user should be aware that increasing the conversion speed also increases the power consumed by the devices. While this increase in power consumption may not cause any issues for the TMP103EVM, users may want to reduce power consumption on certain applications or custom boards. Users should be cautious of this feature.

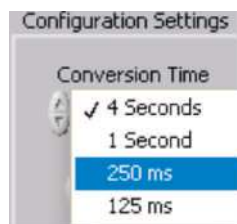
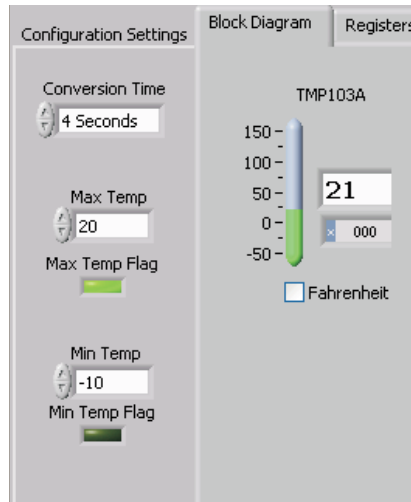

Figure 18. Conversion Time Selection Dialog

### 6.2.4 Max\Min Temp and the Max\Min Temp Flag

The TMP103 sensor has a built-in flag to indicate when a device is measuring temperatures above or below a set range. This flag can be useful to notify the user when ambient temperatures go beyond a desired range. The TMP103 sensor maximum measurable values are from  $-40^{\circ}\text{C}$  to  $+125^{\circ}\text{C}$ . When a temperature violates the max or min temp flag, the respective temp toggles on and remains on until the temperatures return to the designated range. The TMP103A is shown signaling a flag by violating the max temperature in [Figure 19](#).



**Figure 19. Max Temp Flag Trigger**

### 6.2.5 Conversion to Fahrenheit

If the user desires the temperature thermometers to perform measurements in degrees Fahrenheit, this setting can be changed individually by clicking the checkbox beneath the thermometer. If the user desires to change all of these settings at once, simply toggle the **To Fahren** button in the bottom right-hand corner of the software display. See [Figure 16](#).

## 6.2.6 Registers Tab

The Registers tab displays the individual register setting for the TMP103 sensors. It should be noted that the TMP103EVM software keeps all the configuration registers,  $T_{LOW}$  registers, and  $T_{HIGH}$  registers identical. For more information on the individual registers and the bit meanings, simply highlight the desired register and hit the **Help with Reg** button shown in [Figure 20](#).

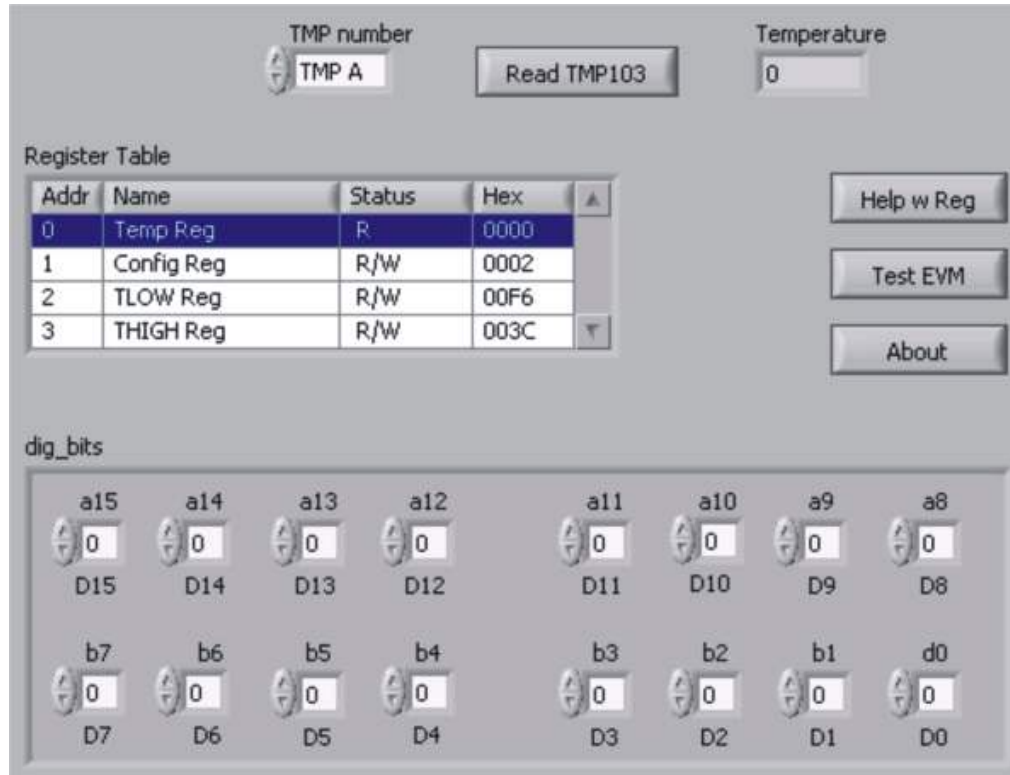

**Figure 20. TMP103EVM Software: Register Tab**

The Registers tab also includes two other features: the *dig\_bits* table and the individual temp read feature. The *dig\_bits* table allows the user to monitor and change individual bits by highlighting the desired register and toggling the bit controls beneath it.

---

**NOTE:** Only writable register bits can be toggled.

---

It is also possible to individually read the temperature sensors on the board using the **Read TMP103** button in the Registers tab. This action yields the same result as the general-call Read All Registers, but does not require the other sensors to be read. The individual read of a TMP sensor is mainly included for reference; TI recommends using the **Read All Reg** button when performing evaluations with the TMP103EVM software.



### 6.2.7 Register Tab: Test EVM

The Register tab for the TMP103EVM test software also includes a sub-routine program to verify communication with the TMP103 devices and run the TMP103 test procedures. By clicking on the **Test EVM** button (refer to [Figure 20](#)), a new window appears as shown in [Figure 21](#).

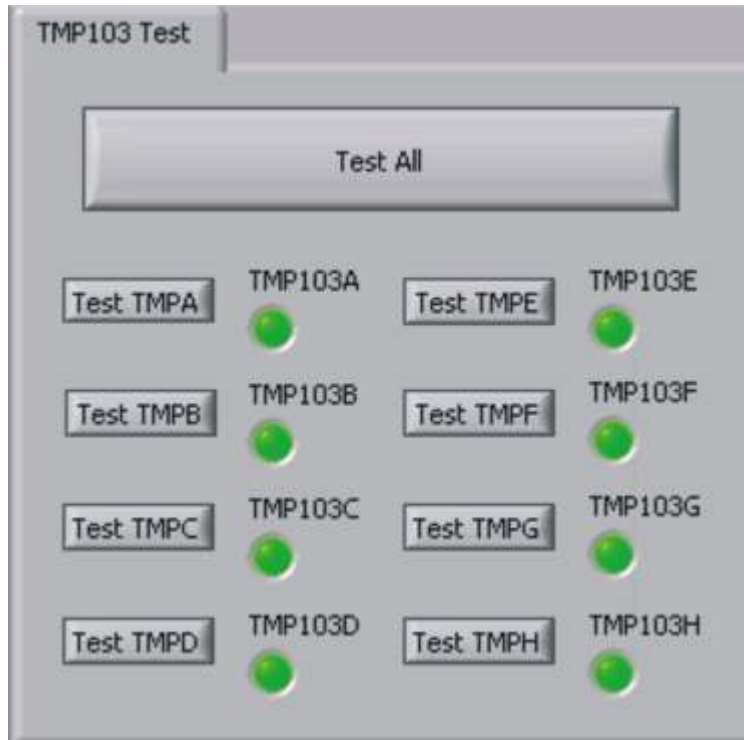

**Figure 21. TMP103EVM Software: Test Procedure**

This secondary program reads each register individually and verifies that the TMP103 sensors produce the required number of *Acknowledges* from the general call and individual communication. To test the general call, use the **Test All** button. To test the sensors individually, use the **Test TMPx** button next to the corresponding LED.

## 7 TMP103EVM Documentation

This section contains the complete bill of materials and a partial schematic diagram for the TMP103EVM. The [TMP103EVM Schematic](#) (SBOR013) is available for download through the TI website. Additional documentation for the SM-USB-DIG Platform can be found in the [SM-USB-DIG Platform User's Guide](#) (SBOU098) available through the TI website.

### 7.1 TMP103EVM Board Schematic

Figure 22 shows the TMP103EVM board schematic.

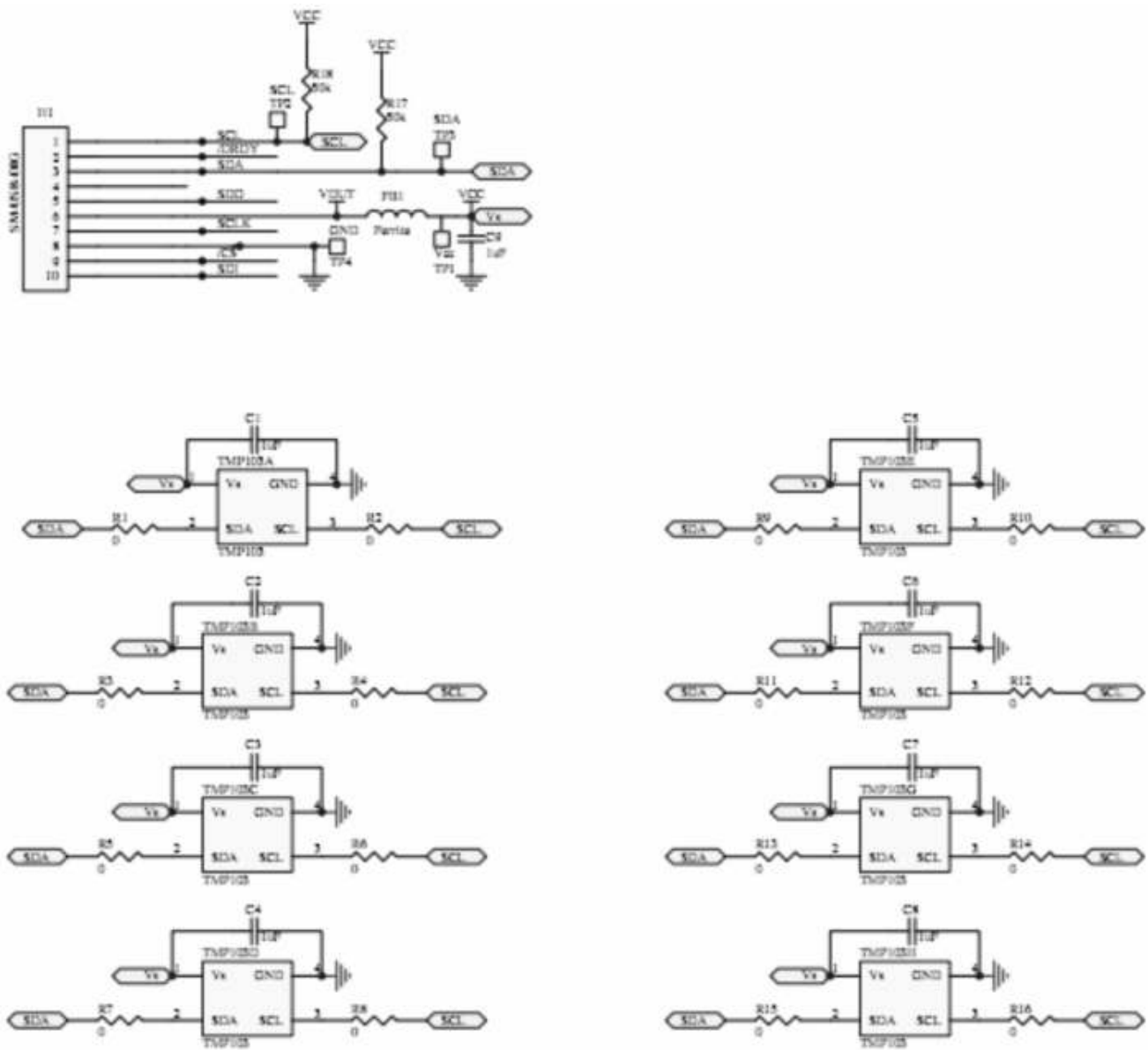

Figure 22. TMP103EVM Schematic

## 7.2 TMP103EVM PCB Components Layout

Figure 23 illustrates the layout of the components for the TMP103EVM board.

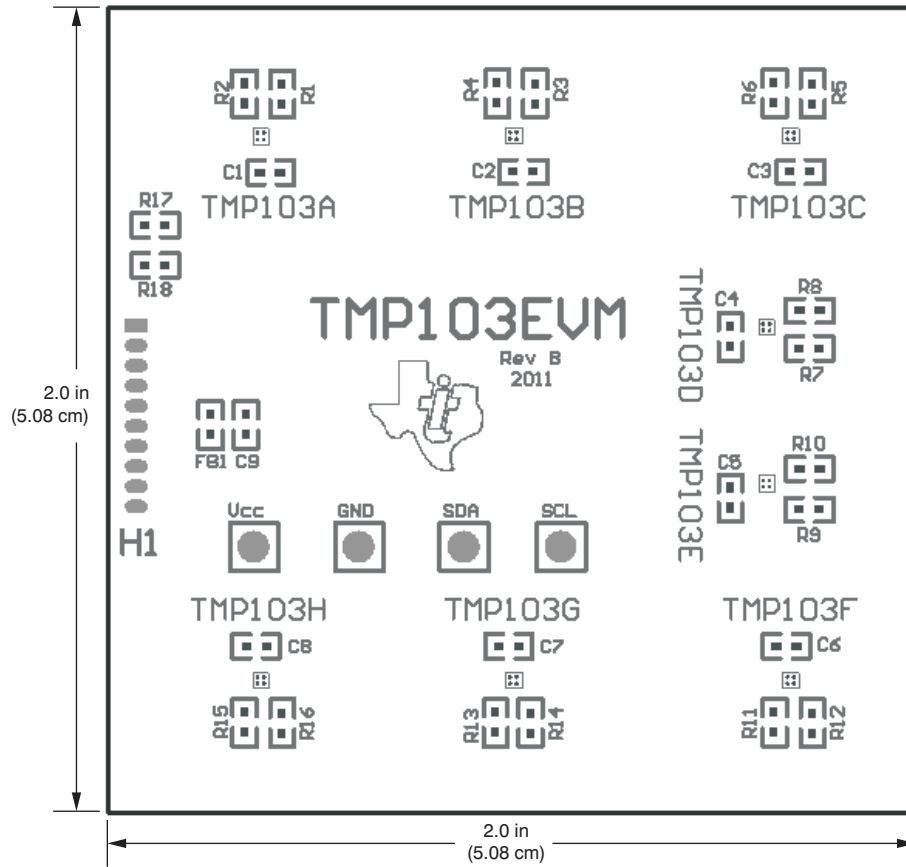

Figure 23. TMP103EVM Component Layout

## 8 Bill of Materials

Table 4 shows the parts list.

**Table 4. Bill of Materials**

Item	Qty	Ref Des	Value	Description	Manufacturer	Part No
1	16	R1 - R16	0 $\Omega$	Resistor, 0.0 OHM 1/16W 0402 SMD	Stackpole Electronics	RMCF0402ZT0R00
2	2	R17, R18	51 k $\Omega$	Resistor, 51K OHM 1/10W 5% 0402 SMD	Panasonic	ERJ-2GEJ513X
3	9	C1 - C9	0.1 $\mu$ F	Capacitor, ceramic 0.1 $\mu$ F 25V Y5V 0402	Yageo	CC0402ZRY5V8BB 104
4	1	FB1	–	Ferrite bead 300 $\Omega$ .2A 0402	Würth	74279272
5	8	TMP103A-H	–	TMP103	Texas Instruments	
6	4	Bumpons	–	Bumpon hemisphere .50x.14 clear	3M	SJ-5312 (CLEAR)
7	1	Super Mini DIG connector Socket	–	Conn socket RT Ang 50POS	—	—
	1	Super Mini DIG connector Socket	–	Conn socket RT Ang 50POS .050	Mill-Max Manufacturing	851-93-050-20- 001000

## Revision History

NOTE: Page numbers for previous revisions may differ from page numbers in the current version.

<b>Changes from Original (January 2011) to A Revision</b>	<b>Page</b>
• Changed the <i>TMP103EVM Software Installation</i> section .....	8
• Changed the Super Mini DIG connector Socket rows (Item #7) in the <i>Bill of Materials</i> .....	20

## Evaluation Board/Kit Important Notice

Texas Instruments (TI) provides the enclosed product(s) under the following conditions:

This evaluation board/kit is intended for use for **ENGINEERING DEVELOPMENT, DEMONSTRATION, OR EVALUATION PURPOSES ONLY** and is not considered by TI to be a finished end-product fit for general consumer use. Persons handling the product(s) must have electronics training and observe good engineering practice standards. As such, the goods being provided are not intended to be complete in terms of required design-, marketing-, and/or manufacturing-related protective considerations, including product safety and environmental measures typically found in end products that incorporate such semiconductor components or circuit boards. This evaluation board/kit does not fall within the scope of the European Union directives regarding electromagnetic compatibility, restricted substances (RoHS), recycling (WEEE), FCC, CE or UL, and therefore may not meet the technical requirements of these directives or other related directives.

Should this evaluation board/kit not meet the specifications indicated in the User's Guide, the board/kit may be returned within 30 days from the date of delivery for a full refund. **THE FOREGOING WARRANTY IS THE EXCLUSIVE WARRANTY MADE BY SELLER TO BUYER AND IS IN LIEU OF ALL OTHER WARRANTIES, EXPRESSED, IMPLIED, OR STATUTORY, INCLUDING ANY WARRANTY OF MERCHANTABILITY OR FITNESS FOR ANY PARTICULAR PURPOSE.**

The user assumes all responsibility and liability for proper and safe handling of the goods. Further, the user indemnifies TI from all claims arising from the handling or use of the goods. Due to the open construction of the product, it is the user's responsibility to take any and all appropriate precautions with regard to electrostatic discharge.

**EXCEPT TO THE EXTENT OF THE INDEMNITY SET FORTH ABOVE, NEITHER PARTY SHALL BE LIABLE TO THE OTHER FOR ANY INDIRECT, SPECIAL, INCIDENTAL, OR CONSEQUENTIAL DAMAGES.**

TI currently deals with a variety of customers for products, and therefore our arrangement with the user **is not exclusive.**

TI assumes **no liability for applications assistance, customer product design, software performance, or infringement of patents or services described herein.**

Please read the User's Guide and, specifically, the Warnings and Restrictions notice in the User's Guide prior to handling the product. This notice contains important safety information about temperatures and voltages. For additional information on TI's environmental and/or safety programs, please contact the TI application engineer or visit [www.ti.com/esh](http://www.ti.com/esh).

No license is granted under any patent right or other intellectual property right of TI covering or relating to any machine, process, or combination in which such TI products or services might be or are used.

## FCC Warning

This evaluation board/kit is intended for use for **ENGINEERING DEVELOPMENT, DEMONSTRATION, OR EVALUATION PURPOSES ONLY** and is not considered by TI to be a finished end-product fit for general consumer use. It generates, uses, and can radiate radio frequency energy and has not been tested for compliance with the limits of computing devices pursuant to part 15 of FCC rules, which are designed to provide reasonable protection against radio frequency interference. Operation of this equipment in other environments may cause interference with radio communications, in which case the user at his own expense will be required to take whatever measures may be required to correct this interference.

## EVM Warnings and Restrictions

It is important to operate this EVM within the input voltage range of 5.7V (min) to 9V (max) and the output voltage range of 0V (min) to 5V (max).

Exceeding the specified input range may cause unexpected operation and/or irreversible damage to the EVM. If there are questions concerning the input range, please contact a TI field representative prior to connecting the input power.

Applying loads outside of the specified output range may result in unintended operation and/or possible permanent damage to the EVM. Please consult the EVM User's Guide prior to connecting any load to the EVM output. If there is uncertainty as to the load specification, please contact a TI field representative.

During normal operation, some circuit components may have case temperatures greater than +25°C. The EVM is designed to operate properly with certain components above +25°C as long as the input and output ranges are maintained. These components include but are not limited to linear regulators, switching transistors, pass transistors, and current sense resistors. These types of devices can be identified using the EVM schematic located in the EVM User's Guide. When placing measurement probes near these devices during operation, please be aware that these devices may be very warm to the touch.

## STANDARD TERMS FOR EVALUATION MODULES

1. *Delivery:* TI delivers TI evaluation boards, kits, or modules, including any accompanying demonstration software, components, and/or documentation which may be provided together or separately (collectively, an "EVM" or "EVMs") to the User ("User") in accordance with the terms set forth herein. User's acceptance of the EVM is expressly subject to the following terms.
  - 1.1 EVMs are intended solely for product or software developers for use in a research and development setting to facilitate feasibility evaluation, experimentation, or scientific analysis of TI semiconductor products. EVMs have no direct function and are not finished products. EVMs shall not be directly or indirectly assembled as a part or subassembly in any finished product. For clarification, any software or software tools provided with the EVM ("Software") shall not be subject to the terms and conditions set forth herein but rather shall be subject to the applicable terms that accompany such Software
  - 1.2 EVMs are not intended for consumer or household use. EVMs may not be sold, sublicensed, leased, rented, loaned, assigned, or otherwise distributed for commercial purposes by Users, in whole or in part, or used in any finished product or production system.
2. *Limited Warranty and Related Remedies/Disclaimers:*
  - 2.1 These terms do not apply to Software. The warranty, if any, for Software is covered in the applicable Software License Agreement.
  - 2.2 TI warrants that the TI EVM will conform to TI's published specifications for ninety (90) days after the date TI delivers such EVM to User. Notwithstanding the foregoing, TI shall not be liable for a nonconforming EVM if (a) the nonconformity was caused by neglect, misuse or mistreatment by an entity other than TI, including improper installation or testing, or for any EVMs that have been altered or modified in any way by an entity other than TI, (b) the nonconformity resulted from User's design, specifications or instructions for such EVMs or improper system design, or (c) User has not paid on time. Testing and other quality control techniques are used to the extent TI deems necessary. TI does not test all parameters of each EVM. User's claims against TI under this Section 2 are void if User fails to notify TI of any apparent defects in the EVMs within ten (10) business days after delivery, or of any hidden defects with ten (10) business days after the defect has been detected.
  - 2.3 TI's sole liability shall be at its option to repair or replace EVMs that fail to conform to the warranty set forth above, or credit User's account for such EVM. TI's liability under this warranty shall be limited to EVMs that are returned during the warranty period to the address designated by TI and that are determined by TI not to conform to such warranty. If TI elects to repair or replace such EVM, TI shall have a reasonable time to repair such EVM or provide replacements. Repaired EVMs shall be warranted for the remainder of the original warranty period. Replaced EVMs shall be warranted for a new full ninety (90) day warranty period.
3. *Regulatory Notices:*
  - 3.1 *United States*
    - 3.1.1 *Notice applicable to EVMs not FCC-Approved:*

**FCC NOTICE:** This kit is designed to allow product developers to evaluate electronic components, circuitry, or software associated with the kit to determine whether to incorporate such items in a finished product and software developers to write software applications for use with the end product. This kit is not a finished product and when assembled may not be resold or otherwise marketed unless all required FCC equipment authorizations are first obtained. Operation is subject to the condition that this product not cause harmful interference to licensed radio stations and that this product accept harmful interference. Unless the assembled kit is designed to operate under part 15, part 18 or part 95 of this chapter, the operator of the kit must operate under the authority of an FCC license holder or must secure an experimental authorization under part 5 of this chapter.
    - 3.1.2 *For EVMs annotated as FCC – FEDERAL COMMUNICATIONS COMMISSION Part 15 Compliant:*

### CAUTION

This device complies with part 15 of the FCC Rules. Operation is subject to the following two conditions: (1) This device may not cause harmful interference, and (2) this device must accept any interference received, including interference that may cause undesired operation.

Changes or modifications not expressly approved by the party responsible for compliance could void the user's authority to operate the equipment.

### FCC Interference Statement for Class A EVM devices

*NOTE: This equipment has been tested and found to comply with the limits for a Class A digital device, pursuant to part 15 of the FCC Rules. These limits are designed to provide reasonable protection against harmful interference when the equipment is operated in a commercial environment. This equipment generates, uses, and can radiate radio frequency energy and, if not installed and used in accordance with the instruction manual, may cause harmful interference to radio communications. Operation of this equipment in a residential area is likely to cause harmful interference in which case the user will be required to correct the interference at his own expense.*

## FCC Interference Statement for Class B EVM devices

*NOTE: This equipment has been tested and found to comply with the limits for a Class B digital device, pursuant to part 15 of the FCC Rules. These limits are designed to provide reasonable protection against harmful interference in a residential installation. This equipment generates, uses and can radiate radio frequency energy and, if not installed and used in accordance with the instructions, may cause harmful interference to radio communications. However, there is no guarantee that interference will not occur in a particular installation. If this equipment does cause harmful interference to radio or television reception, which can be determined by turning the equipment off and on, the user is encouraged to try to correct the interference by one or more of the following measures:*

- Reorient or relocate the receiving antenna.
- Increase the separation between the equipment and receiver.
- Connect the equipment into an outlet on a circuit different from that to which the receiver is connected.
- Consult the dealer or an experienced radio/TV technician for help.

### 3.2 Canada

3.2.1 For EVMs issued with an Industry Canada Certificate of Conformance to RSS-210 or RSS-247

#### Concerning EVMs Including Radio Transmitters:

This device complies with Industry Canada license-exempt RSSs. Operation is subject to the following two conditions:

(1) this device may not cause interference, and (2) this device must accept any interference, including interference that may cause undesired operation of the device.

#### Concernant les EVMs avec appareils radio:

Le présent appareil est conforme aux CNR d'Industrie Canada applicables aux appareils radio exempts de licence. L'exploitation est autorisée aux deux conditions suivantes: (1) l'appareil ne doit pas produire de brouillage, et (2) l'utilisateur de l'appareil doit accepter tout brouillage radioélectrique subi, même si le brouillage est susceptible d'en compromettre le fonctionnement.

#### Concerning EVMs Including Detachable Antennas:

Under Industry Canada regulations, this radio transmitter may only operate using an antenna of a type and maximum (or lesser) gain approved for the transmitter by Industry Canada. To reduce potential radio interference to other users, the antenna type and its gain should be so chosen that the equivalent isotropically radiated power (e.i.r.p.) is not more than that necessary for successful communication. This radio transmitter has been approved by Industry Canada to operate with the antenna types listed in the user guide with the maximum permissible gain and required antenna impedance for each antenna type indicated. Antenna types not included in this list, having a gain greater than the maximum gain indicated for that type, are strictly prohibited for use with this device.

#### Concernant les EVMs avec antennes détachables

Conformément à la réglementation d'Industrie Canada, le présent émetteur radio peut fonctionner avec une antenne d'un type et d'un gain maximal (ou inférieur) approuvé pour l'émetteur par Industrie Canada. Dans le but de réduire les risques de brouillage radioélectrique à l'intention des autres utilisateurs, il faut choisir le type d'antenne et son gain de sorte que la puissance isotrope rayonnée équivalente (p.i.r.e.) ne dépasse pas l'intensité nécessaire à l'établissement d'une communication satisfaisante. Le présent émetteur radio a été approuvé par Industrie Canada pour fonctionner avec les types d'antenne énumérés dans le manuel d'usage et ayant un gain admissible maximal et l'impédance requise pour chaque type d'antenne. Les types d'antenne non inclus dans cette liste, ou dont le gain est supérieur au gain maximal indiqué, sont strictement interdits pour l'exploitation de l'émetteur.

### 3.3 Japan

3.3.1 *Notice for EVMs delivered in Japan:* Please see [http://www.tij.co.jp/lstds/ti\\_ja/general/eStore/notice\\_01.page](http://www.tij.co.jp/lstds/ti_ja/general/eStore/notice_01.page) 日本国内に輸入される評価用キット、ボードについては、次のところをご覧ください。  
[http://www.tij.co.jp/lstds/ti\\_ja/general/eStore/notice\\_01.page](http://www.tij.co.jp/lstds/ti_ja/general/eStore/notice_01.page)

3.3.2 *Notice for Users of EVMs Considered "Radio Frequency Products" in Japan:* EVMs entering Japan may not be certified by TI as conforming to Technical Regulations of Radio Law of Japan.

If User uses EVMs in Japan, not certified to Technical Regulations of Radio Law of Japan, User is required to follow the instructions set forth by Radio Law of Japan, which includes, but is not limited to, the instructions below with respect to EVMs (which for the avoidance of doubt are stated strictly for convenience and should be verified by User):

1. Use EVMs in a shielded room or any other test facility as defined in the notification #173 issued by Ministry of Internal Affairs and Communications on March 28, 2006, based on Sub-section 1.1 of Article 6 of the Ministry's Rule for Enforcement of Radio Law of Japan,
2. Use EVMs only after User obtains the license of Test Radio Station as provided in Radio Law of Japan with respect to EVMs, or
3. Use of EVMs only after User obtains the Technical Regulations Conformity Certification as provided in Radio Law of Japan with respect to EVMs. Also, do not transfer EVMs, unless User gives the same notice above to the transferee. Please note that if User does not follow the instructions above, User will be subject to penalties of Radio Law of Japan.



【無線電波を送信する製品の開発キットをお使いになる際の注意事項】 開発キットの中には技術基準適合証明を受けていないものがあります。技術適合証明を受けていないものご使用に際しては、電波法遵守のため、以下のいずれかの措置を取っていただく必要がありますのでご注意ください。

1. 電波法施行規則第6条第1項第1号に基づく平成18年3月28日総務省告示第173号で定められた電波暗室等の試験設備でご使用いただく。
2. 実験局の免許を取得後ご使用いただく。
3. 技術基準適合証明を取得後ご使用いただく。

なお、本製品は、上記の「ご使用にあたっての注意」を譲渡先、移転先に通知しない限り、譲渡、移転できないものとします。

上記を遵守頂けない場合は、電波法の罰則が適用される可能性があることをご留意ください。日本テキサス・インスツルメンツ株式会社  
東京都新宿区西新宿 6 丁目 2 4 番 1 号  
西新宿三井ビル

3.3.3 *Notice for EVMs for Power Line Communication:* Please see [http://www.tij.co.jp/llds/ti\\_ja/general/eStore/notice\\_02.page](http://www.tij.co.jp/llds/ti_ja/general/eStore/notice_02.page)  
電力線搬送波通信についての開発キットをお使いになる際の注意事項については、次のところをご覧ください。 [http://www.tij.co.jp/llds/ti\\_ja/general/eStore/notice\\_02.page](http://www.tij.co.jp/llds/ti_ja/general/eStore/notice_02.page)

#### 3.4 *European Union*

##### 3.4.1 *For EVMs subject to EU Directive 2014/30/EU (Electromagnetic Compatibility Directive):*

This is a class A product intended for use in environments other than domestic environments that are connected to a low-voltage power-supply network that supplies buildings used for domestic purposes. In a domestic environment this product may cause radio interference in which case the user may be required to take adequate measures.

#### 4 *EVM Use Restrictions and Warnings:*

4.1 EVMS ARE NOT FOR USE IN FUNCTIONAL SAFETY AND/OR SAFETY CRITICAL EVALUATIONS, INCLUDING BUT NOT LIMITED TO EVALUATIONS OF LIFE SUPPORT APPLICATIONS.

4.2 User must read and apply the user guide and other available documentation provided by TI regarding the EVM prior to handling or using the EVM, including without limitation any warning or restriction notices. The notices contain important safety information related to, for example, temperatures and voltages.

##### 4.3 *Safety-Related Warnings and Restrictions:*

4.3.1 User shall operate the EVM within TI's recommended specifications and environmental considerations stated in the user guide, other available documentation provided by TI, and any other applicable requirements and employ reasonable and customary safeguards. Exceeding the specified performance ratings and specifications (including but not limited to input and output voltage, current, power, and environmental ranges) for the EVM may cause personal injury or death, or property damage. If there are questions concerning performance ratings and specifications, User should contact a TI field representative prior to connecting interface electronics including input power and intended loads. Any loads applied outside of the specified output range may also result in unintended and/or inaccurate operation and/or possible permanent damage to the EVM and/or interface electronics. Please consult the EVM user guide prior to connecting any load to the EVM output. If there is uncertainty as to the load specification, please contact a TI field representative. During normal operation, even with the inputs and outputs kept within the specified allowable ranges, some circuit components may have elevated case temperatures. These components include but are not limited to linear regulators, switching transistors, pass transistors, current sense resistors, and heat sinks, which can be identified using the information in the associated documentation. When working with the EVM, please be aware that the EVM may become very warm.

4.3.2 EVMs are intended solely for use by technically qualified, professional electronics experts who are familiar with the dangers and application risks associated with handling electrical mechanical components, systems, and subsystems. User assumes all responsibility and liability for proper and safe handling and use of the EVM by User or its employees, affiliates, contractors or designees. User assumes all responsibility and liability to ensure that any interfaces (electronic and/or mechanical) between the EVM and any human body are designed with suitable isolation and means to safely limit accessible leakage currents to minimize the risk of electrical shock hazard. User assumes all responsibility and liability for any improper or unsafe handling or use of the EVM by User or its employees, affiliates, contractors or designees.

4.4 User assumes all responsibility and liability to determine whether the EVM is subject to any applicable international, federal, state, or local laws and regulations related to User's handling and use of the EVM and, if applicable, User assumes all responsibility and liability for compliance in all respects with such laws and regulations. User assumes all responsibility and liability for proper disposal and recycling of the EVM consistent with all applicable international, federal, state, and local requirements.

5. *Accuracy of Information:* To the extent TI provides information on the availability and function of EVMs, TI attempts to be as accurate as possible. However, TI does not warrant the accuracy of EVM descriptions, EVM availability or other information on its websites as accurate, complete, reliable, current, or error-free.

6. *Disclaimers:*
- 6.1 EXCEPT AS SET FORTH ABOVE, EVMS AND ANY MATERIALS PROVIDED WITH THE EVM (INCLUDING, BUT NOT LIMITED TO, REFERENCE DESIGNS AND THE DESIGN OF THE EVM ITSELF) ARE PROVIDED "AS IS" AND "WITH ALL FAULTS." TI DISCLAIMS ALL OTHER WARRANTIES, EXPRESS OR IMPLIED, REGARDING SUCH ITEMS, INCLUDING BUT NOT LIMITED TO ANY EPIDEMIC FAILURE WARRANTY OR IMPLIED WARRANTIES OF MERCHANTABILITY OR FITNESS FOR A PARTICULAR PURPOSE OR NON-INFRINGEMENT OF ANY THIRD PARTY PATENTS, COPYRIGHTS, TRADE SECRETS OR OTHER INTELLECTUAL PROPERTY RIGHTS.
- 6.2 EXCEPT FOR THE LIMITED RIGHT TO USE THE EVM SET FORTH HEREIN, NOTHING IN THESE TERMS SHALL BE CONSTRUED AS GRANTING OR CONFERRING ANY RIGHTS BY LICENSE, PATENT, OR ANY OTHER INDUSTRIAL OR INTELLECTUAL PROPERTY RIGHT OF TI, ITS SUPPLIERS/LICENSORS OR ANY OTHER THIRD PARTY, TO USE THE EVM IN ANY FINISHED END-USER OR READY-TO-USE FINAL PRODUCT, OR FOR ANY INVENTION, DISCOVERY OR IMPROVEMENT, REGARDLESS OF WHEN MADE, CONCEIVED OR ACQUIRED.
7. *USER'S INDEMNITY OBLIGATIONS AND REPRESENTATIONS.* USER WILL DEFEND, INDEMNIFY AND HOLD TI, ITS LICENSORS AND THEIR REPRESENTATIVES HARMLESS FROM AND AGAINST ANY AND ALL CLAIMS, DAMAGES, LOSSES, EXPENSES, COSTS AND LIABILITIES (COLLECTIVELY, "CLAIMS") ARISING OUT OF OR IN CONNECTION WITH ANY HANDLING OR USE OF THE EVM THAT IS NOT IN ACCORDANCE WITH THESE TERMS. THIS OBLIGATION SHALL APPLY WHETHER CLAIMS ARISE UNDER STATUTE, REGULATION, OR THE LAW OF TORT, CONTRACT OR ANY OTHER LEGAL THEORY, AND EVEN IF THE EVM FAILS TO PERFORM AS DESCRIBED OR EXPECTED.
8. *Limitations on Damages and Liability:*
- 8.1 *General Limitations.* IN NO EVENT SHALL TI BE LIABLE FOR ANY SPECIAL, COLLATERAL, INDIRECT, PUNITIVE, INCIDENTAL, CONSEQUENTIAL, OR EXEMPLARY DAMAGES IN CONNECTION WITH OR ARISING OUT OF THESE TERMS OR THE USE OF THE EVMS , REGARDLESS OF WHETHER TI HAS BEEN ADVISED OF THE POSSIBILITY OF SUCH DAMAGES. EXCLUDED DAMAGES INCLUDE, BUT ARE NOT LIMITED TO, COST OF REMOVAL OR REINSTALLATION, ANCILLARY COSTS TO THE PROCUREMENT OF SUBSTITUTE GOODS OR SERVICES, RETESTING, OUTSIDE COMPUTER TIME, LABOR COSTS, LOSS OF GOODWILL, LOSS OF PROFITS, LOSS OF SAVINGS, LOSS OF USE, LOSS OF DATA, OR BUSINESS INTERRUPTION. NO CLAIM, SUIT OR ACTION SHALL BE BROUGHT AGAINST TI MORE THAN TWELVE (12) MONTHS AFTER THE EVENT THAT GAVE RISE TO THE CAUSE OF ACTION HAS OCCURRED.
- 8.2 *Specific Limitations.* IN NO EVENT SHALL TI'S AGGREGATE LIABILITY FROM ANY USE OF AN EVM PROVIDED HEREUNDER, INCLUDING FROM ANY WARRANTY, INDEMNITY OR OTHER OBLIGATION ARISING OUT OF OR IN CONNECTION WITH THESE TERMS, , EXCEED THE TOTAL AMOUNT PAID TO TI BY USER FOR THE PARTICULAR EVM(S) AT ISSUE DURING THE PRIOR TWELVE (12) MONTHS WITH RESPECT TO WHICH LOSSES OR DAMAGES ARE CLAIMED. THE EXISTENCE OF MORE THAN ONE CLAIM SHALL NOT ENLARGE OR EXTEND THIS LIMIT.
9. *Return Policy.* Except as otherwise provided, TI does not offer any refunds, returns, or exchanges. Furthermore, no return of EVM(s) will be accepted if the package has been opened and no return of the EVM(s) will be accepted if they are damaged or otherwise not in a resalable condition. If User feels it has been incorrectly charged for the EVM(s) it ordered or that delivery violates the applicable order, User should contact TI. All refunds will be made in full within thirty (30) working days from the return of the components(s), excluding any postage or packaging costs.
10. *Governing Law:* These terms and conditions shall be governed by and interpreted in accordance with the laws of the State of Texas, without reference to conflict-of-laws principles. User agrees that non-exclusive jurisdiction for any dispute arising out of or relating to these terms and conditions lies within courts located in the State of Texas and consents to venue in Dallas County, Texas. Notwithstanding the foregoing, any judgment may be enforced in any United States or foreign court, and TI may seek injunctive relief in any United States or foreign court.

## IMPORTANT NOTICE FOR TI DESIGN INFORMATION AND RESOURCES

Texas Instruments Incorporated ("TI") technical, application or other design advice, services or information, including, but not limited to, reference designs and materials relating to evaluation modules, (collectively, "TI Resources") are intended to assist designers who are developing applications that incorporate TI products; by downloading, accessing or using any particular TI Resource in any way, you (individually or, if you are acting on behalf of a company, your company) agree to use it solely for this purpose and subject to the terms of this Notice.

TI's provision of TI Resources does not expand or otherwise alter TI's applicable published warranties or warranty disclaimers for TI products, and no additional obligations or liabilities arise from TI providing such TI Resources. TI reserves the right to make corrections, enhancements, improvements and other changes to its TI Resources.

You understand and agree that you remain responsible for using your independent analysis, evaluation and judgment in designing your applications and that you have full and exclusive responsibility to assure the safety of your applications and compliance of your applications (and of all TI products used in or for your applications) with all applicable regulations, laws and other applicable requirements. You represent that, with respect to your applications, you have all the necessary expertise to create and implement safeguards that (1) anticipate dangerous consequences of failures, (2) monitor failures and their consequences, and (3) lessen the likelihood of failures that might cause harm and take appropriate actions. You agree that prior to using or distributing any applications that include TI products, you will thoroughly test such applications and the functionality of such TI products as used in such applications. TI has not conducted any testing other than that specifically described in the published documentation for a particular TI Resource.

You are authorized to use, copy and modify any individual TI Resource only in connection with the development of applications that include the TI product(s) identified in such TI Resource. NO OTHER LICENSE, EXPRESS OR IMPLIED, BY ESTOPPEL OR OTHERWISE TO ANY OTHER TI INTELLECTUAL PROPERTY RIGHT, AND NO LICENSE TO ANY TECHNOLOGY OR INTELLECTUAL PROPERTY RIGHT OF TI OR ANY THIRD PARTY IS GRANTED HEREIN, including but not limited to any patent right, copyright, mask work right, or other intellectual property right relating to any combination, machine, or process in which TI products or services are used. Information regarding or referencing third-party products or services does not constitute a license to use such products or services, or a warranty or endorsement thereof. Use of TI Resources may require a license from a third party under the patents or other intellectual property of the third party, or a license from TI under the patents or other intellectual property of TI.

TI RESOURCES ARE PROVIDED "AS IS" AND WITH ALL FAULTS. TI DISCLAIMS ALL OTHER WARRANTIES OR REPRESENTATIONS, EXPRESS OR IMPLIED, REGARDING TI RESOURCES OR USE THEREOF, INCLUDING BUT NOT LIMITED TO ACCURACY OR COMPLETENESS, TITLE, ANY EPIDEMIC FAILURE WARRANTY AND ANY IMPLIED WARRANTIES OF MERCHANTABILITY, FITNESS FOR A PARTICULAR PURPOSE, AND NON-INFRINGEMENT OF ANY THIRD PARTY INTELLECTUAL PROPERTY RIGHTS.

TI SHALL NOT BE LIABLE FOR AND SHALL NOT DEFEND OR INDEMNIFY YOU AGAINST ANY CLAIM, INCLUDING BUT NOT LIMITED TO ANY INFRINGEMENT CLAIM THAT RELATES TO OR IS BASED ON ANY COMBINATION OF PRODUCTS EVEN IF DESCRIBED IN TI RESOURCES OR OTHERWISE. IN NO EVENT SHALL TI BE LIABLE FOR ANY ACTUAL, DIRECT, SPECIAL, COLLATERAL, INDIRECT, PUNITIVE, INCIDENTAL, CONSEQUENTIAL OR EXEMPLARY DAMAGES IN CONNECTION WITH OR ARISING OUT OF TI RESOURCES OR USE THEREOF, AND REGARDLESS OF WHETHER TI HAS BEEN ADVISED OF THE POSSIBILITY OF SUCH DAMAGES.

You agree to fully indemnify TI and its representatives against any damages, costs, losses, and/or liabilities arising out of your non-compliance with the terms and provisions of this Notice.

This Notice applies to TI Resources. Additional terms apply to the use and purchase of certain types of materials, TI products and services. These include; without limitation, TI's standard terms for semiconductor products (<http://www.ti.com/sc/docs/stdterms.htm>), [evaluation modules](#), and [samples](http://www.ti.com/sc/docs/sampterm.htm) (<http://www.ti.com/sc/docs/sampterm.htm>).

Mailing Address: Texas Instruments, Post Office Box 655303, Dallas, Texas 75265  
Copyright © 2018, Texas Instruments Incorporated