

THIS DRAWING AND THE INFORMATION SET FORTH HEREON ARE THE PROPERTY OF TYCO ELECTRONICS CORPORATION, AND ARE TO BE HELD IN TRUST AND CONFIDENCE. PUBLICATION, DUPLICATION, DISCLOSURE, OR USE FOR ANY PURPOSE NOT EXPRESSLY AUTHORIZED IN WRITING BY TYCO ELECTRONICS CORPORATION IS PROHIBITED.

REVISIONS			
LTR	DESCRIPTION	DATE	APPROVED
B	REVISED PER DCR# T-28331	11/9/2000	M.HIGGY
C	ECO-09-002665	Feb/3/09	M.HIGGY

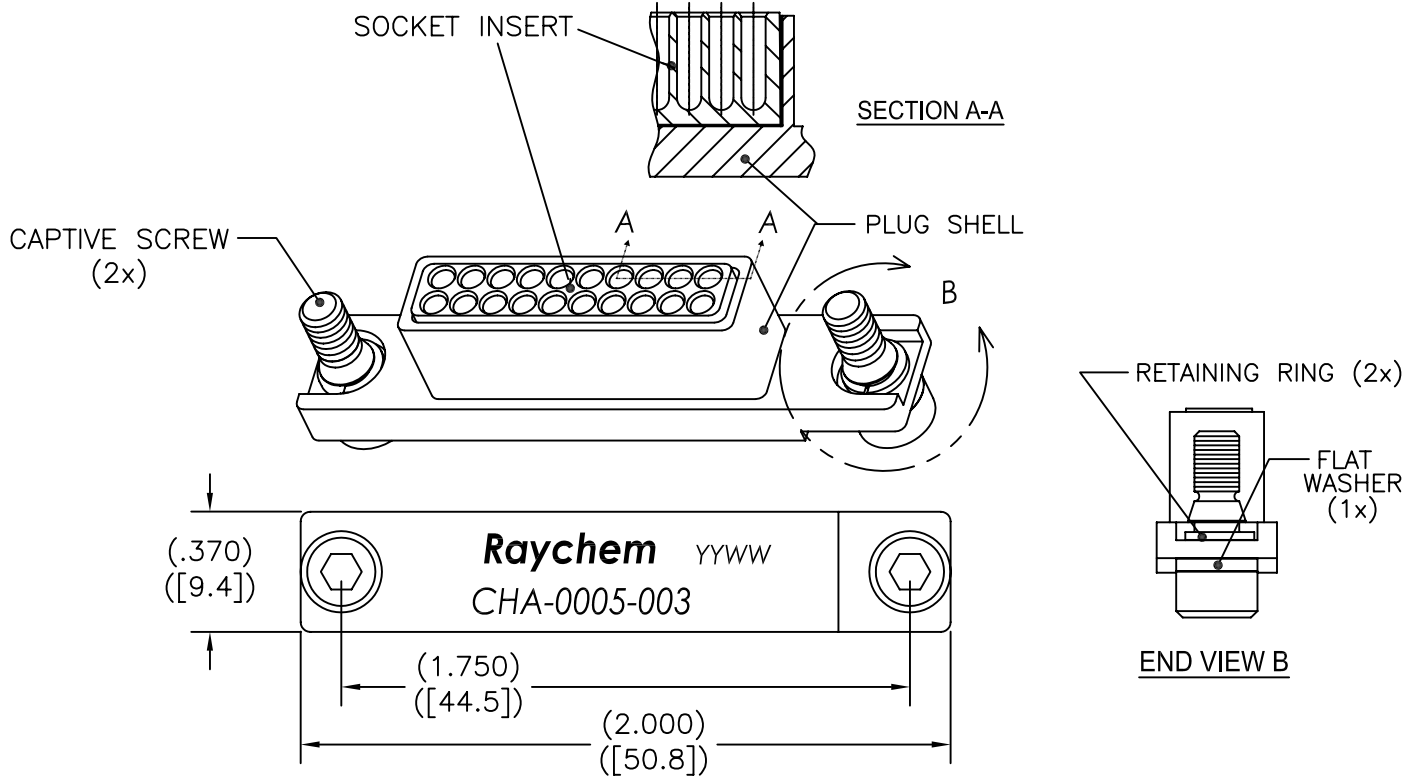

NOTES:

1. PROTECTIVE CAP PUG WITH SOCKET INSERT, MTC100 SERIES 1 INCH, DESIGNED TO ENVIRONMENTALLY SEAL THE MATING RECEPTACLE SHELL WITH PIN CONTACTS.

2. PLUG SHELL:

MATERIAL: ALUMINUM ALLOY PER ASTM B85 4291 (QQ-A-591) OR SAE-AMS-QQ-A-225.
FINISH: CADMIUM PLATED PER SAE-AMS-QQ-P-416 OVER NICKEL UNDER-PLATE.

SOCKET INSERT:

MATERIAL: HARD PLASTIC PER ASTM D 5948-96 (MIL-M-14, TYPE MFH).

CAPTIVE SCREW:

MATERIAL: STAINLESS STEEL PER ASTM A 240 (QQ-S-766).
FINISH: CADMIUM PLATED PER SAE-AMS-QQ-P-416.

RETAINING RING:

MATERIAL: COPPER ALLOY 172 PER ASTM B194
FINISH: CADMIUM PLATED PER SAE-AMS-QQ-P-416, CLASS 2, TYPE II.

FLAT WASHER:

MATERIAL: STAINLESS STEEL PER ASTM A 240/A 240M
FINISH: CADMIUM PLATED PER SAE-AMS-QQ-P-416.

3. WEIGHT: 0.023 LBS [10.6 Grams] MAXIMUM.

If this document is printed it becomes uncontrolled. Check for the latest revision

© 2009 Tyco Electronics. All rights reserved.

CUSTOMER DRAWING

UNLESS OTHERWISE SPECIFIED DIMENSIONS ARE IN INCHES. METRIC DIMENSIONS ARE IN BRACKETS.

DECIMALS
.XX ± .015 [.38 mm]
.XXX ± .010 [.25 mm]

ANGLES
.X ± ---

REDRAWN ZSOFIA ORBAN	DATE Jan/29/09
CHECKED ---	DATE ---
APPROVED ---	DATE ---
APPROVED M. HIGGY	DATE Jan/29/09
CAD NAME CHA-0005-003	



Raychem Interconnect
300 Constitution Drive
Menlo Park, CA 94025 U.S.A

TITLE
1 INCH PROTECTIVE CAP PLUG, WITH
SOCKET INSERT, CADMIUM PLATED
MTC 100 SERIES

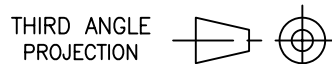

SIZE A	CAGE CODE: 06090	DWG. NO. CHA-0005-003	REV C
DO NOT SCALE THIS DWG		SHEET 1 OF 1	