

## **Not Recommended for New Designs**

---

This product was manufactured for Maxim by an outside wafer foundry using a process that is no longer available. It is not recommended for new designs. The data sheet remains available for existing users.

A Maxim replacement or an industry second-source may be available. Please see the QuickView data sheet for this part or contact technical support for assistance.

For further information, [contact Maxim's Applications Tech Support](#).

# MAXIM

## 10 $\mu$ A, Low-Dropout, Precision Voltage References

MAX872/MAX874

### General Description

The MAX872/MAX874 precision 2.5V and 4.096V micro-power voltage references consume a maximum of only 10 $\mu$ A and operate from supply voltages up to 20V. The combination of ultra-low quiescent current and low 200mV dropout makes them ideal for battery-powered equipment. They source and sink up to 500 $\mu$ A with only 200mV input voltage headroom, which makes the 2.5V MAX872 ideal for use with a 3V supply and the 4.096V MAX874 ideal for use with a 5V supply.

Initial accuracy of 0.2% at +25°C ( $\pm$ 5mV for the MAX872,  $\pm$ 8mV for the MAX874) and low 40ppm/°C max drift make these references suitable for a wide range of precision applications.

### Applications

Hand-Held Instruments  
Battery-Operated Equipment  
Power Supplies

### Typical Operating Circuit

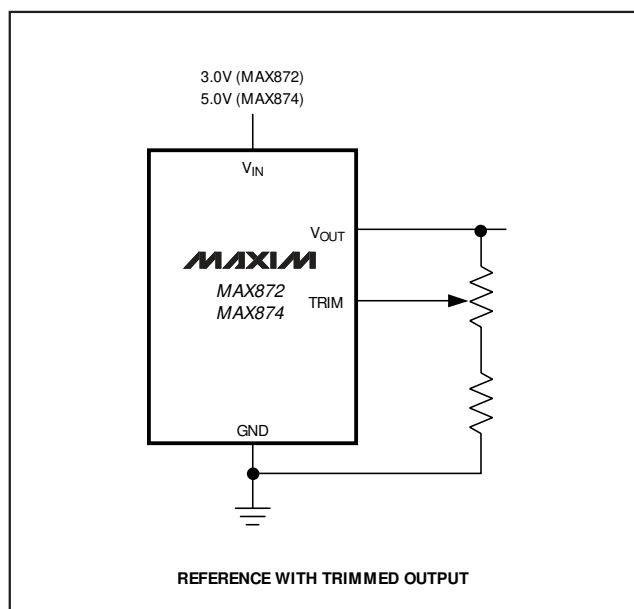

### Features

- ◆ Output Voltage
  - 2.500V  $\pm$ 0.2% (MAX872)
  - 4.096V  $\pm$ 0.2% (MAX874)
- ◆ Wide Operating Voltage Range
  - 2.7V to 20V (MAX872)
  - 4.3V to 20V (MAX874)
- ◆ 10 $\mu$ A Max Supply Current
- ◆ 40ppm/°C Max Drift Over Extended Temp. Range
- ◆ Line Regulation Over Temp.
  - 20 $\mu$ V/V (MAX872)
  - 75 $\mu$ V/V (MAX874)
- ◆ Load Regulation Over Temp.
  - 0.6mV/mA Max (MAX872)
  - 1.0mV/mA Max (MAX874)
- ◆  $\pm$ 500 $\mu$ A Sink/Source Current

### Ordering Information

PART	TEMP. RANGE	PIN-PACKAGE
MAX872CPA	0°C to +70°C	8 Plastic DIP
MAX872CSA	0°C to +70°C	8 SO
MAX872C/D	0°C to +70°C	Dice*
MAX872EPA	-40°C to +85°C	8 Plastic DIP
MAX872ESA	-40°C to +85°C	8 SO
MAX874CPA	0°C to +70°C	8 Plastic DIP
MAX874CSA	0°C to +70°C	8 SO
MAX874C/D	0°C to +70°C	Dice*
MAX874EPA	-40°C to +85°C	8 Plastic DIP
MAX874ESA	-40°C to +85°C	8 SO

\* Dice are specified at +25°C only.

### Pin Configuration

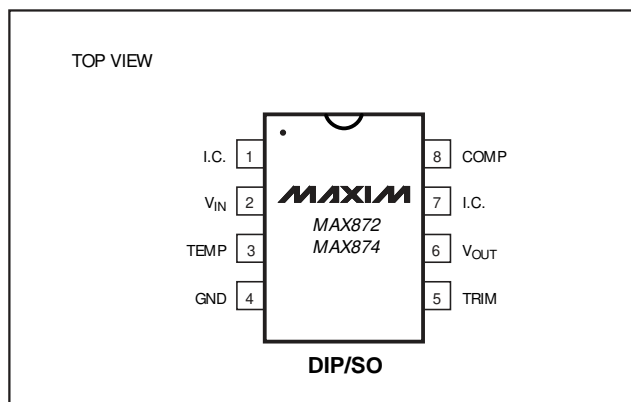

# 10 $\mu$ A, Low-Dropout, Precision Voltage References

## ABSOLUTE MAXIMUM RATINGS

Supply Voltage	.....24V
Output Short-Circuit Duration	.....Continuous to Either Supply
C <sub>COMP</sub> Input	.....-0.3V to V <sub>OUT</sub>
TRIM Input	.....-0.3V to (V <sub>IN</sub> + 0.3V)
TEMP Output	.....-0.3V to (V <sub>IN</sub> + 0.3V)
Continuous Power Dissipation (T <sub>A</sub> = +70°C)	
Plastic DIP (derate 9.09mW/°C above +70°C)	.....727mW
SO (derate 5.88mW/°C above +70°C)	.....471mW

### Operating Temperature Ranges

MAX87_C	.....0°C to +70°C
MAX87_E	.....-40°C to +85°C
Storage Temperature Range	.....-65°C to +150°C
Junction Temperature Range (T <sub>j</sub> )	.....-65°C to +160°C
Lead Temperature (soldering, 10sec)	.....+300°C

Stresses beyond those listed under "Absolute Maximum Ratings" may cause permanent damage to the device. These are stress ratings only, and functional operation of the device at these or any other conditions beyond those indicated in the operational sections of the specifications is not implied. Exposure to absolute maximum rating conditions for extended periods may affect device reliability.

## ELECTRICAL CHARACTERISTICS—MAX872

(V<sub>IN</sub> = 2.7V, I<sub>L</sub> = 0mA, T<sub>A</sub> = +25°C, unless otherwise noted.)

PARAMETER	SYMBOL	CONDITIONS	MIN	TYP	MAX	UNITS
Output Voltage	V <sub>OUT</sub>		2.495	2.500	2.505	V
Output Voltage Noise	e <sub>n</sub>	0.1Hz to 10Hz		60		$\mu$ Vp-p
Line Regulation	V <sub>OUT</sub> /V <sub>IN</sub>	V <sub>IN</sub> = 4.5V to 20V		4	12	$\mu$ V/V
		V <sub>IN</sub> = 2.7V to 5.5V		80	250	
Load Regulation (Note 1)	V <sub>OUT</sub> /I <sub>OUT</sub>	Sourcing 0mA to 0.5mA		0.2	0.5	mV/mA
		Sinking 0mA to -0.5mA		4	12	
Quiescent Supply Current	I <sub>Q</sub>			6.5	10	$\mu$ A
Change in Supply Current vs. V <sub>IN</sub>	I <sub>Q</sub> /V <sub>IN</sub>	V <sub>IN</sub> = 2.7V to 20V		0.35	0.55	$\mu$ A/V
Short-Circuit Output Current	I <sub>SC</sub>	V <sub>OUT</sub> short to GND		6	15	mA
		V <sub>OUT</sub> short to V <sub>IN</sub>		3	9	
TEMP Voltage	V <sub>TEMP</sub>			690		mV
V <sub>OUT</sub> Adjustment Range	V <sub>ADJ</sub>	V <sub>OUT</sub> $\geq$ V <sub>OUT</sub> + 0.2V		+75/-20	+100/-25	mV

## ELECTRICAL CHARACTERISTICS—MAX874

(V<sub>IN</sub> = 4.3V, I<sub>L</sub> = 0mA, T<sub>A</sub> = +25°C, unless otherwise noted.)

PARAMETER	SYMBOL	CONDITIONS	MIN	TYP	MAX	UNITS
Output Voltage	V <sub>OUT</sub>		4.088	4.096	4.104	V
Output Voltage Noise	e <sub>n</sub>	0.1Hz to 10Hz		90		$\mu$ Vp-p
Line Regulation	V <sub>OUT</sub> /V <sub>IN</sub>	V <sub>IN</sub> = 4.3V to 20V		15	75	$\mu$ V/V
Load Regulation (Note 1)	V <sub>OUT</sub> /I <sub>OUT</sub>	Sourcing 0mA to 0.5mA		0.15	0.9	mV/mA
		Sinking 0mA to -0.5mA		6	15	
Quiescent Supply Current	I <sub>Q</sub>			6.5	10	$\mu$ A
Change in Supply Current vs. V <sub>IN</sub>	I <sub>Q</sub> /V <sub>IN</sub>	V <sub>IN</sub> = 4.3V to 20V		0.35	0.55	$\mu$ A/V
Short-Circuit Output Current	I <sub>SC</sub>	V <sub>OUT</sub> short to GND		6	15	mA
		V <sub>OUT</sub> short to V <sub>IN</sub>		5	25	
TEMP Voltage	V <sub>TEMP</sub>			690		mV
V <sub>OUT</sub> Adjustment Range	V <sub>ADJ</sub>	V <sub>OUT</sub> $\geq$ V <sub>OUT</sub> + 0.2V		$\pm$ 150	$\pm$ 200	mV

# 10 $\mu$ A, Low-Dropout, Precision Voltage References

MAX872/MAX874

## ELECTRICAL CHARACTERISTICS—MAX872C

( $V_{IN} = 2.7V$ ,  $I_L = 0mA$ ,  $T_A = 0^{\circ}C$  to  $+70^{\circ}C$ , unless otherwise noted.)

PARAMETER	SYMBOL	CONDITIONS	MIN	TYP	MAX	UNITS
Output Voltage	$V_{OUT}$		2.4905		2.5095	V
Output Voltage Temperature Coefficient	$TCV_{OUT}$			20	40	ppm/ $^{\circ}C$
Line Regulation	$V_{OUT}/V_{IN}$	$V_{IN} = 4.5V$ to $20V$			20	$\mu V/V$
		$V_{IN} = 2.7V$ to $5.5V$			300	
Load Regulation (Note 1)	$V_{OUT}/I_{OUT}$	Sourcing $0mA$ to $0.4mA$			0.6	mV/mA
		Sinking $0mA$ to $-0.4mA$			15	
Quiescent Supply Current	$I_Q$				15	$\mu A$
Change in Supply Current vs. $V_{IN}$	$I_Q/V_{IN}$	$V_{IN} = 2.7V$ to $20V$			0.7	$\mu A/V$
$V_{OUT}$ Adjustment Range	$V_{ADJ}$	$V_{IN} \geq V_{OUT} + 0.2V$	+75/-20			mV
TEMP Output Temperature Coefficient	$TCV_{TEMP}$			2.3		mV/ $^{\circ}C$

## ELECTRICAL CHARACTERISTICS—MAX874C

( $V_{IN} = 4.3V$ ,  $I_L = 0mA$ ,  $T_A = 0^{\circ}C$  to  $+70^{\circ}C$ , unless otherwise noted.)

PARAMETER	SYMBOL	CONDITIONS	MIN	TYP	MAX	UNITS
Output Voltage	$V_{OUT}$		4.0805		4.1115	V
Output Voltage Temperature Coefficient	$TCV_{OUT}$			20	40	ppm/ $^{\circ}C$
Line Regulation	$V_{OUT}/V_{IN}$	$V_{IN} = 4.3V$ to $20V$			75	$\mu V/V$
Load Regulation (Note 1)	$V_{OUT}/I_{OUT}$	Sourcing $0mA$ to $0.4mA$			1.0	mV/mA
		Sinking $0mA$ to $-0.4mA$			25	
Quiescent Supply Current	$I_Q$				15	$\mu A$
Change in Supply Current vs. $V_{IN}$	$I_Q/V_{IN}$	$V_{IN} = 4.3V$ to $20V$			0.7	$\mu A/V$
$V_{OUT}$ Adjustment Range	$V_{ADJ}$	$V_{IN} \geq V_{OUT} + 0.2V$	$\pm 150$			mV
TEMP Output Temperature Coefficient	$TCV_{TEMP}$			2.3		mV/ $^{\circ}C$

**Note 1:** If the load current exceeds  $300\mu A$ , connect a minimum of  $1000pF$  from  $V_{OUT}$  to GND. Note that if a capacitor larger than  $1000pF$  is used, a compensation capacitor of  $C_{OUT}/100$  must be connected from  $V_{OUT}$  to COMP.

# 10 $\mu$ A, Low-Dropout, Precision Voltage References

## ELECTRICAL CHARACTERISTICS—MAX872E

( $V_{IN} = 2.7V$ ,  $I_L = 0mA$ ,  $T_A = -40^{\circ}C$  to  $+85^{\circ}C$ , unless otherwise noted.)

PARAMETER	SYMBOL	CONDITIONS	MIN	TYP	MAX	UNITS
Output Voltage	$V_{OUT}$		2.488		2.512	V
Output Voltage Temperature Coefficient	$TCV_{OUT}$			20	40	ppm/ $^{\circ}C$
Line Regulation	$V_{OUT}/V_{IN}$	$V_{IN} = 4.5V$ to $20V$			20	$\mu V/V$
		$V_{IN} = 2.7V$ to $5.5V$			300	
Load Regulation	$V_{OUT}/I_{OUT}$	Sourcing $0mA$ to $0.30mA$			0.6	mV/mA
		Sinking $0mA$ to $-0.30mA$			15	
Quiescent Supply Current	$I_Q$				15	$\mu A$
Change in Supply Current vs. $V_{IN}$	$I_Q/V_{IN}$	$V_{IN} = 2.7V$ to $20V$			0.7	$\mu A/V$
$V_{OUT}$ Adjustment Range	$V_{ADJ}$	$V_{IN} \geq V_{OUT} + 0.2V$	+75/-20			mV
TEMP Output Temperature Coefficient	$TCV_{TEMP}$			2.3		mV/ $^{\circ}C$

## ELECTRICAL CHARACTERISTICS—MAX874E

( $V_{IN} = 4.3V$ ,  $I_L = 0mA$ ,  $T_A = -40^{\circ}C$  to  $+85^{\circ}C$ , unless otherwise noted.)

PARAMETER	SYMBOL	CONDITIONS	MIN	TYP	MAX	UNITS
Output Voltage	$V_{OUT}$		4.077		4.115	V
Output Voltage Temperature Coefficient	$TCV_{OUT}$			20	40	ppm/ $^{\circ}C$
Line Regulation	$V_{OUT}/V_{IN}$	$V_{IN} = 4.3V$ to $20V$			75	$\mu V/V$
Load Regulation	$V_{OUT}/I_{OUT}$	Sourcing $0mA$ to $0.30mA$			1.0	mV/mA
		Sinking $0mA$ to $-0.30mA$			25	
Quiescent Supply Current	$I_Q$				15	$\mu A$
Change in Supply Current vs. $V_{IN}$	$I_Q/V_{IN}$	$V_{IN} = 4.3V$ to $20V$			0.7	$\mu A/V$
$V_{OUT}$ Adjustment Range	$V_{ADJ}$	$V_{IN} \geq V_{OUT} + 0.2V$	$\pm 150$			mV
TEMP Output Temperature Coefficient	$TCV_{TEMP}$			2.3		mV/ $^{\circ}C$

# 10 $\mu$ A, Low-Dropout, Precision Voltage References

## Typical Operating Characteristics

( $V_{IN} = 3V$  (MAX872),  $V_{IN} = 5V$  (MAX874), no load,  $T_A = +25^\circ C$ , unless otherwise noted.)

MAX872/MAX874

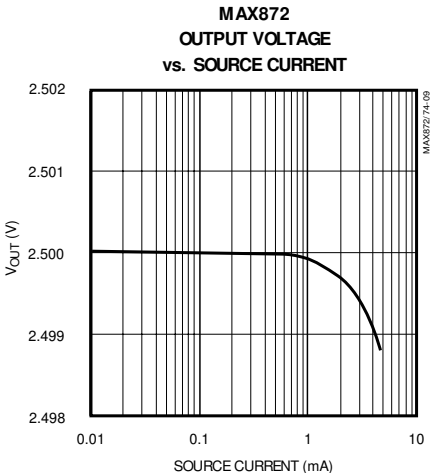
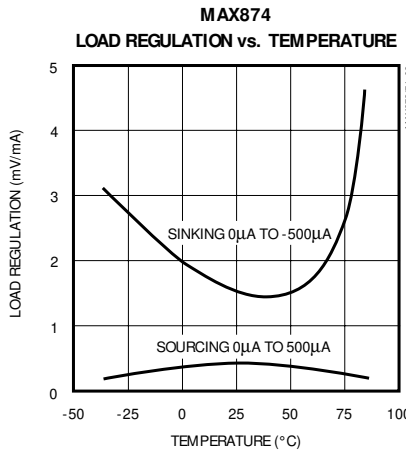
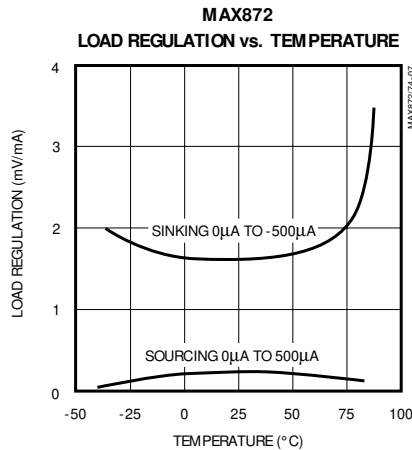
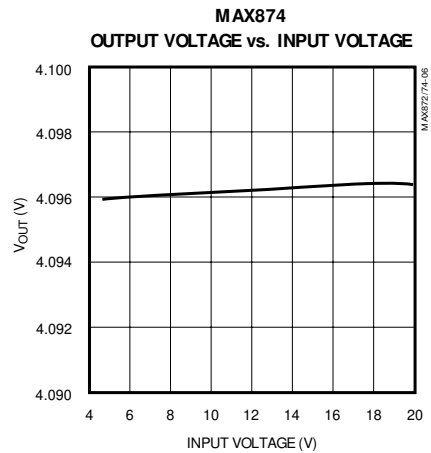
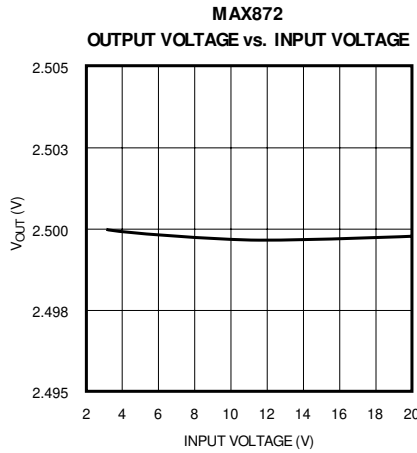
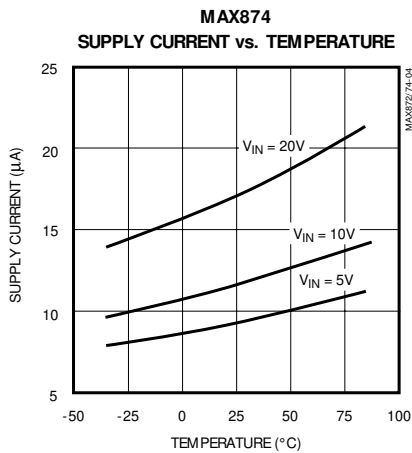
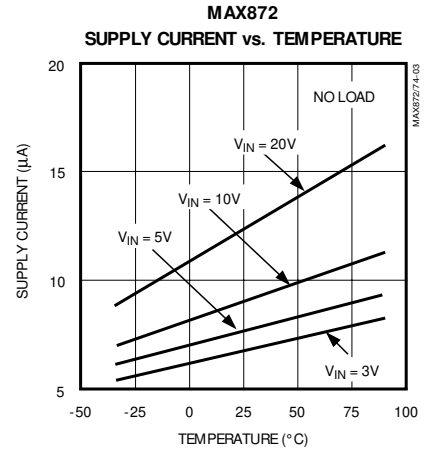
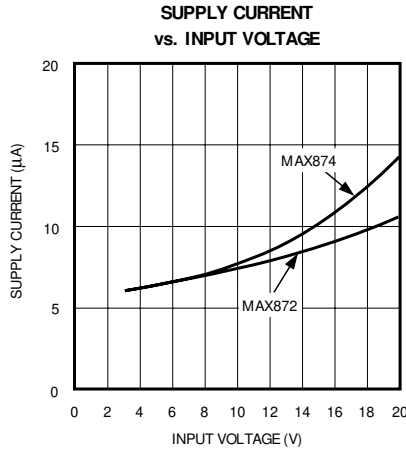
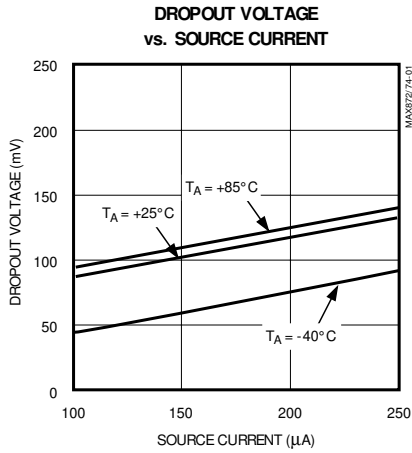

# 10 $\mu$ A, Low-Dropout, Precision Voltage References

## Typical Operating Characteristics (continued)

( $V_{IN} = 3V$  (MAX872),  $V_{IN} = 5V$  (MAX874), no load,  $T_A = +25^\circ C$ , unless otherwise noted.)

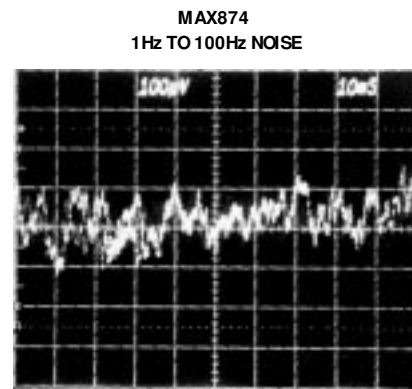
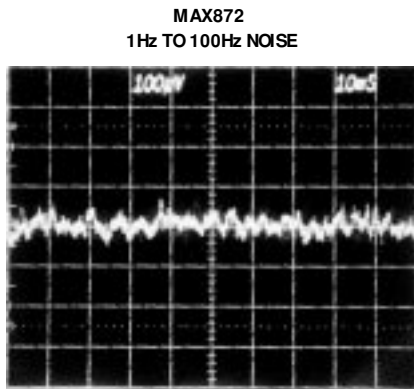
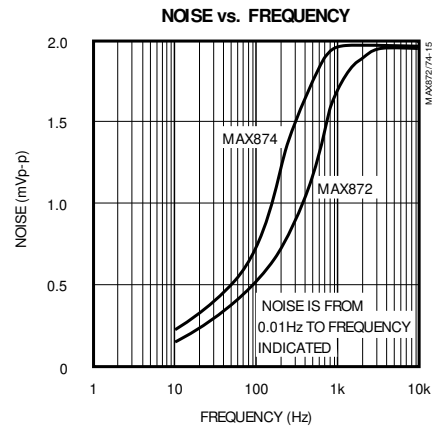
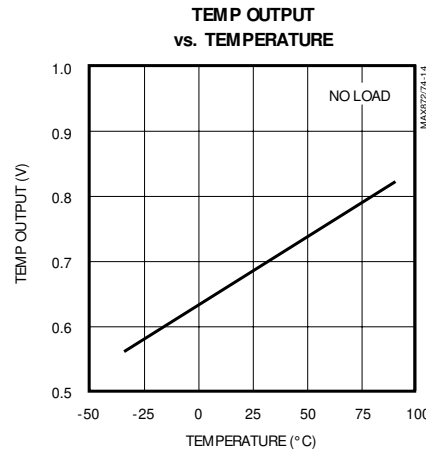
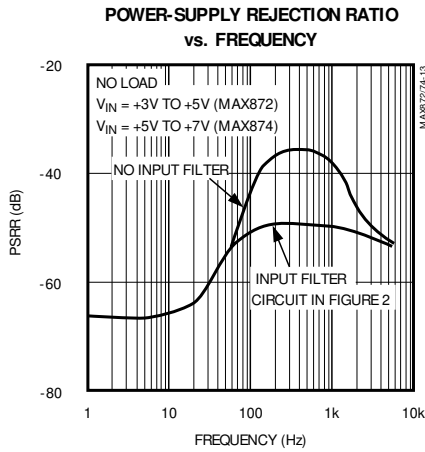
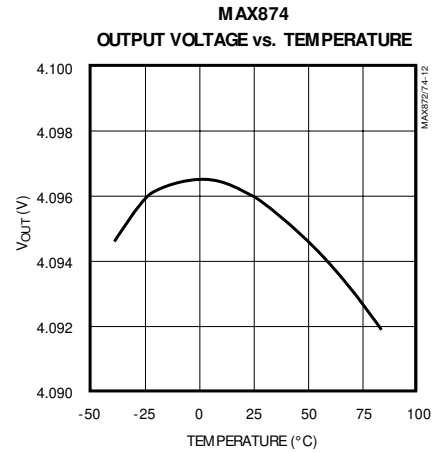
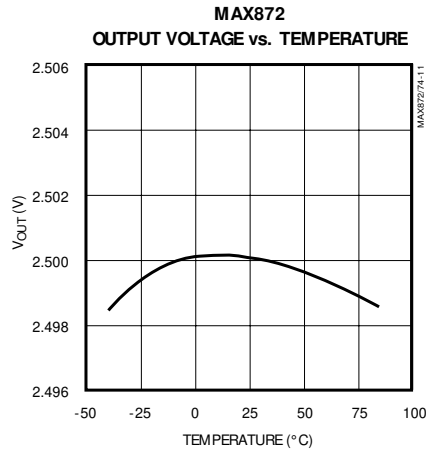
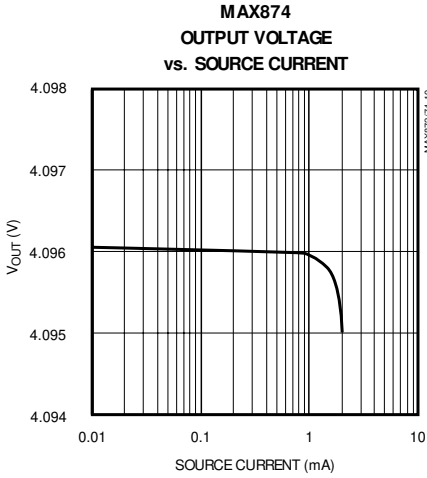

# 10 $\mu$ A, Low-Dropout, Precision Voltage References

MAX872/MAX874

## Pin Description

PIN	NAME	FUNCTION
1, 7	I.C.	Internal Connection. Make no connection to this pin
2	V <sub>IN</sub>	Input Voltage
3	TEMP	Temperature-Proportional Output Voltage. Generates an output voltage proportional to junction temperature.
4	GND	Ground
5	TRIM	Output Voltage Trim. Connect to the center of a voltage divider for output trimming. Otherwise make no connection.
6	V <sub>OUT</sub>	Reference Output
8	COMP	Compensation Input. Connect C <sub>LOAD</sub> /100 capacitor from V <sub>OUT</sub> to COMP to provide capacitive load compensation.

## Applications Information

### Trimming the Output Voltage

The MAX872/MAX874's output voltage is trimmed for 0.2% tolerance at +25°C. If additional V<sub>OUT</sub> trimming is desired, connect a potentiometer to TRIM, as shown in Figures 1a and 1b. Adjusting V<sub>OUT</sub> away from its factory-trimmed voltage typically changes the output voltage tempco by 7ppm/°C per 100mV.

### Reducing Input Ripple with an Input Filter

The Power-Supply Rejection Ratio vs. Frequency graph in the *Typical Operating Characteristics* shows ripple rejection between 10Hz and 2kHz. As input RC filter with a pole less than 10Hz, as shown in Figure 2, further attenuates input ripple with this band. The voltage drop across the input resistor (due to supply and load current) slightly increases the dropout voltage. The increase is given by [(I<sub>LOAD</sub> + I<sub>SUPPLY</sub>) • R].

### Choosing the Output and Compensation Capacitors

Connecting a capacitor between V<sub>OUT</sub> and GND reduces load transients. If the load exceeds 300 $\mu$ A, connect a minimum of 1000pF from V<sub>OUT</sub> to GND. The type of capacitor is not critical. If the total load capacitance from V<sub>OUT</sub> to GND (C<sub>LOAD</sub> = output capacitor + other capacitive load) is larger than 1000pF, connect a compensation capacitor with a value of C<sub>LOAD</sub>/100 between COMP and V<sub>OUT</sub>.

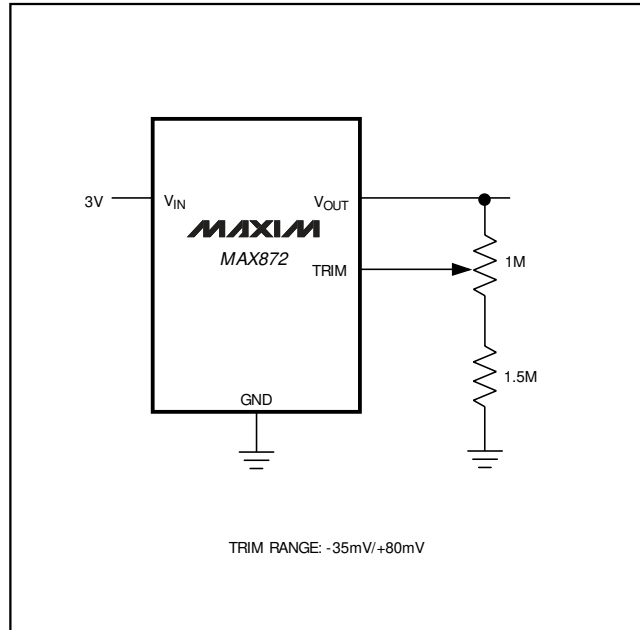

Figure 1a. Adjusting V<sub>OUT</sub> with the TRIM Input on the MAX872

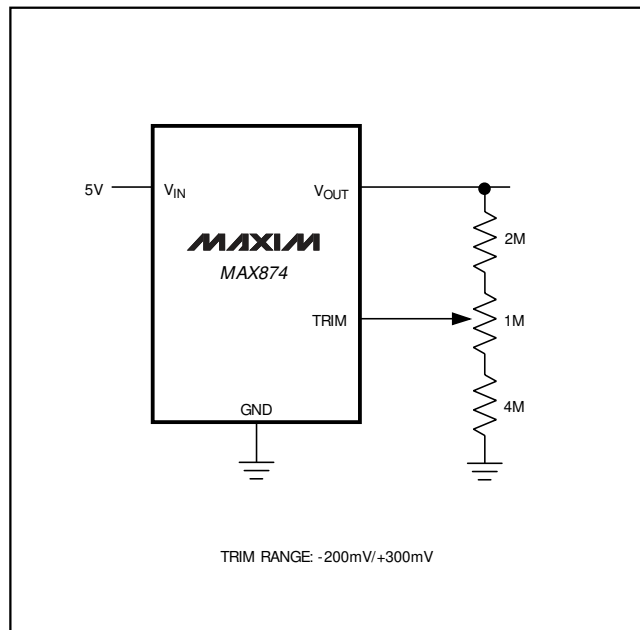

Figure 1b. Adjusting V<sub>OUT</sub> with the TRIM Input on the MAX874



# 10µA, Low-Dropout, Precision Voltage References

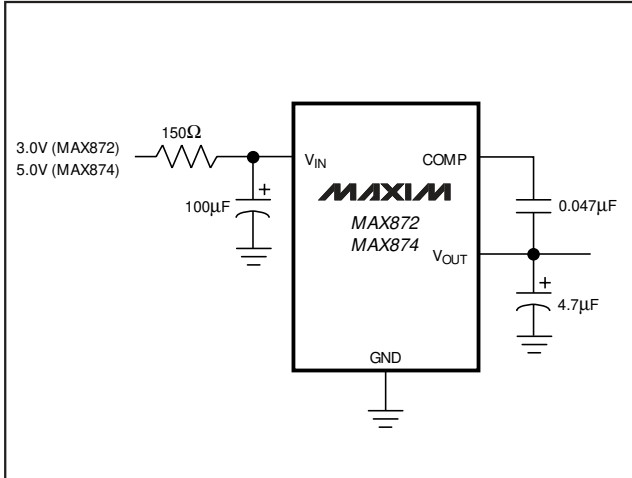

Figure 2. Input Filter Reduces Input Ripple

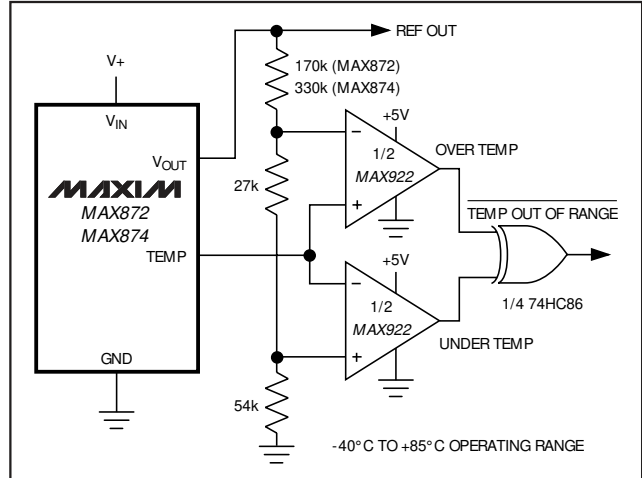

Figure 3. Operating Temperature Range Window Comparator

## TEMP Output

The TEMP output provides a voltage proportional to the MAX872/MAX874 junction temperature. Since the power dissipation of the MAX872/MAX874 is  $<100\mu\text{W}$  typ, the junction temperature is within  $0.5^\circ\text{C}$  of the ambient temperature. Although it goes unused in most applications, the ambient temperature information given by the TEMP output may be used to control LCD contrast, or to provide ADC gain compensation or thermal out-of-range indication. TEMP must be buffered or connected to a high-impedance input.

## Operating Temperature Window Comparator

In Figure 3, a window comparator monitors the TEMP output and indicates if the temperature is out of the nominal operating range. For the resistor values shown, the circuit will indicate an out-of-range condition if the ambient temperature should rise above  $+85^\circ\text{C}$  or dip below  $-40^\circ\text{C}$ .

## Start-Up

When the input voltage is below the factory-selected output voltage, the MAX872/MAX874 can draw excessive supply current (hundreds of microamps). If the source resistance is too high, the voltage drop across the source resistance can prevent the input voltage to the device from reaching the minimum dropout voltage. Therefore, when using the MAX872/MAX874 in low-dropout applications, ensure that the power supply has a low source resistance.

## Chip Topography

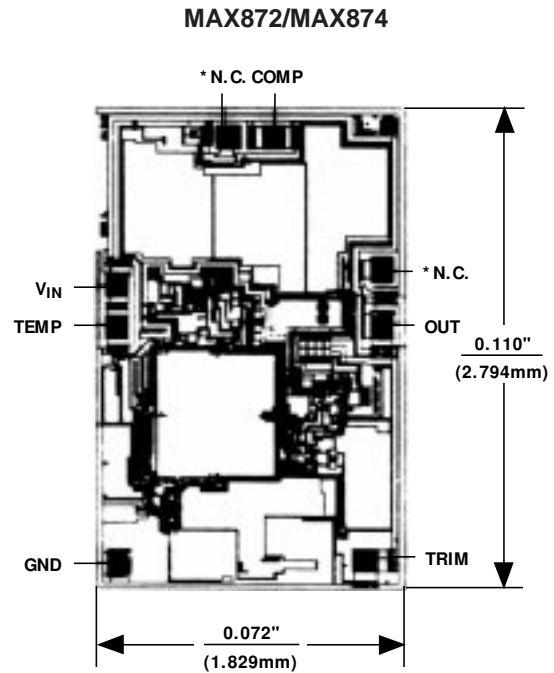

\* MAKE NO CONNECTIONS TO THESE PADS

TRANSISTOR COUNT: 89

SUBSTRATE CONNECTED TO GND.

Maxim cannot assume responsibility for use of any circuitry other than circuitry entirely embodied in a Maxim product. No circuit patent licenses are implied. Maxim reserves the right to change the circuitry and specifications without notice at any time.

8 Maxim Integrated Products, 120 San Gabriel Drive, Sunnyvale, CA 94086 408-737-7600