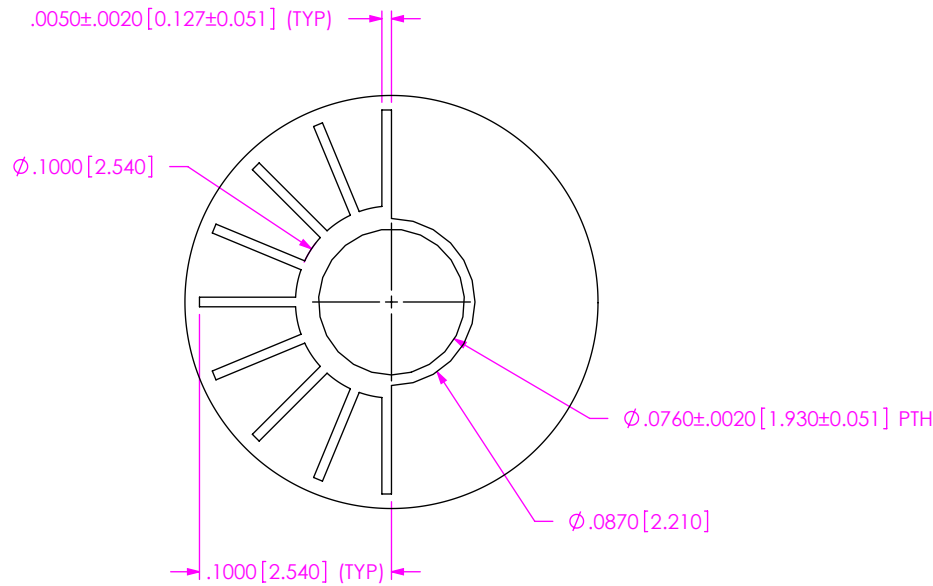

FIG 1
MEC1-160-XX-XX-D-RAX-SL PCB LAYOUT (POLARIZED OPTION SHOWN)



DETAIL 'A'
SCALE 10:1

# POSITIONS	"D"	"E"
-05	N/A	N/A
-08	.039 [1.00]	N/A
-20	.236 [6.00]	N/A
-30	.354 [9.00]	N/A
-40	.551 [14.00]	N/A
-50	.748 [19.00]	N/A
-60	.551 [14.00]	1.181 [30.00]
-70	.984 [25.00]	2.205 [56.00]

UNLESS OTHERWISE SPECIFIED,
DIMENSIONS ARE IN INCHES.
TOLERANCES ARE:

DECIMALS ANGLES
.XX: ±.010[0.25] 2°
.XXX: ±.005[0.13]
.XXXX: ±.0020[0.051]

PROPRIETARY NOTE
THIS DOCUMENT CONTAINS CONFIDENTIAL AND
PROPRIETARY INFORMATION AND ALL DESIGN,
MANUFACTURING, REPRODUCTION, USE, PATENT RIGHTS
AND SALES RIGHTS ARE EXPRESSLY RESERVED BY SAMTEC,
INC. THIS DOCUMENT SHALL NOT BE DISCLOSED, IN WHOLE
OR PART, TO ANY UNAUTHORIZED PERSON OR ENTITY NOR
REPRODUCED, TRANSFERRED OR INCORPORATED IN ANY
OTHER PROJECT IN ANY MANNER WITHOUT THE EXPRESS
WRITTEN CONSENT OF SAMTEC, INC.



520 PARK EAST BLVD, NEW ALBANY, IN 47150
PHONE: 812-944-6733 FAX: 812-948-5047
e-Mail info@SAMTEC.com code 55322

NOTE:
STENCIL TO BE .0060[.152] THICK.

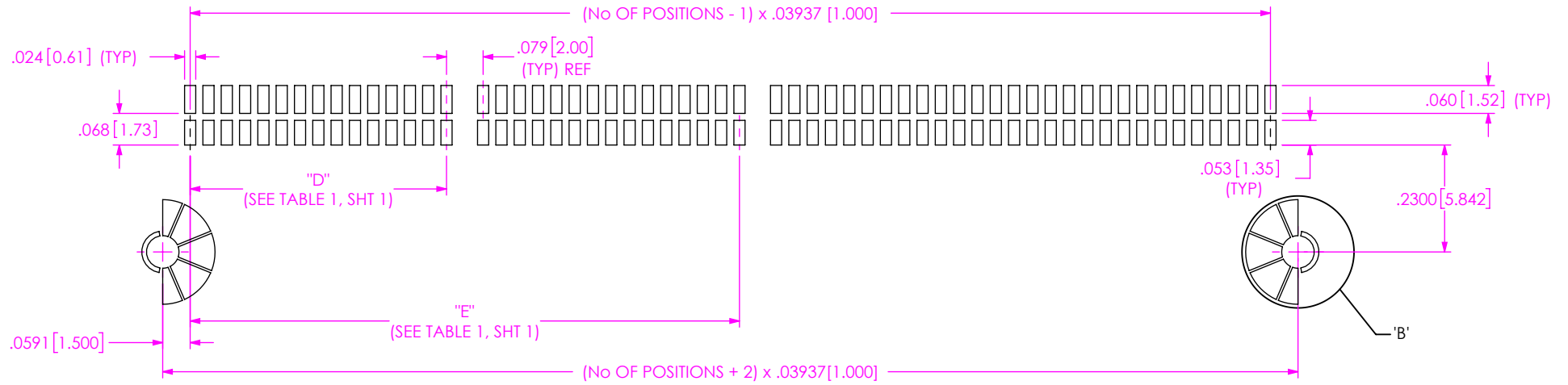
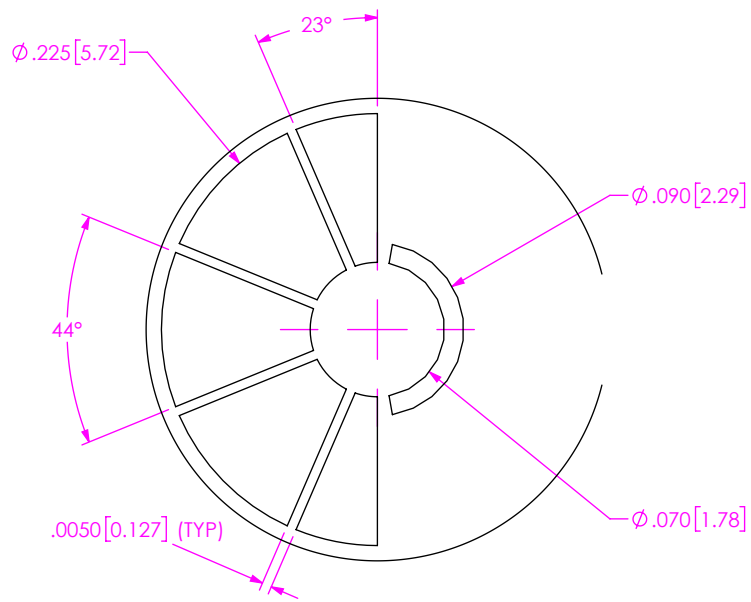
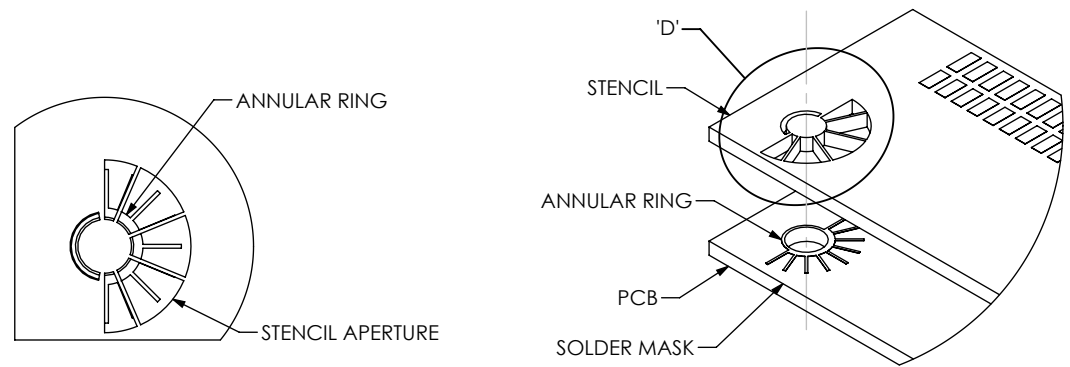

FIG 2
MEC1-160-XX-XX-D-RAX-SL STENCIL LAYOUT SHOWN



DETAIL 'B'
SCALE 10:1



DETAIL 'D'
SCALE 4:1

• PROPRIETARY NOTE •
THIS DOCUMENT CONTAINS CONFIDENTIAL AND PROPRIETARY INFORMATION AND ALL DESIGN, MANUFACTURING, REPRODUCTION, USE, PATENT RIGHTS AND SALES RIGHTS ARE EXPRESSLY RESERVED BY SAMTEC, INC. THIS DOCUMENT SHALL NOT BE DISCLOSED, IN WHOLE OR PART, TO ANY UNAUTHORIZED PERSON OR ENTITY NOR REPRODUCED, TRANSFERRED OR INCORPORATED IN ANY OTHER PROJECT IN ANY MANNER WITHOUT THE EXPRESS WRITTEN CONSENT OF SAMTEC, INC.



520 PARK EAST BLVD, NEW ALBANY, IN 47150
PHONE: 812-944-6733 FAX: 812-948-5047
e-Mail info@SAMTEC.com code 55322

REVISION N RECOMMENDED MATING CARD LAYOUT FOR MEC1-1XX-XX-XX-D-RAX-XX-SL-XX

TABLE 1

POSITION	"A" (CARD SLOT 1)	"B" (CARD SLOT 2)	"F"	"G"
-05	.094 [2.39]	N/A	0.266 [6.75]	0.1576 [4.003]
-08	.133 [3.38]	N/A	0.384 [9.75]	0.2758 [7.005]
-20	.330 [8.38]	N/A	0.857 [21.76]	0.7486 [19.014]
-30	.448 [11.38]	N/A	1.251 [31.77]	1.1426 [29.022]
-40	.645 [16.38]	N/A	1.645 [41.78]	1.5366 [39.030]
-50	.842 [21.39]	N/A	2.039 [51.79]	1.9306 [49.037]
-60	.645 [16.38]	1.275 [32.37]	2.433 [61.79]	2.3246 [59.045]
-70	1.078 [27.38]	2.298 [58.37]	2.827 [71.80]	2.7186 [69.052]

NOTES:

1. -60 AND -70 ARE THE ONLY TWO CARDS THAT HAVE TWO SLOTS.
2. MIRROR IMAGE FOOTPRINT ON THE OTHER SIDE OF PCB.
3. FOR NON-POLARIZED OPTION, REPLACE SLOTS WITH TRACES.
4. ALL DIMENSIONS ARE SYMMETRIC ABOUT CENTERLINE.
5. PLATING TO BE .000030 INCHES GOLD WITH HARDNESS 130-200 KNOOP PER ASTM B488 TYPE 2, GRADE C.
6. POSITIONS -05, -08, -20 & -30 ARE POLARIZED UNLESS OTHERWISE NOTED WITH OPTION -NP.
7. FOR PROPER CONTACT REGISTRATION, PLATING BUS TIES TO BE WIDTH OF THE EDGE FINGER.
8. FOR APPLICATIONS REQUIRING INVERTED REFLOW SOLDERING, USE OF AN EPOXY ADHESIVE IS RECOMMENDED.

N

FIG 3

MEC1-160-02-X-D-RAX-XX-SL MATING CARD SHOWN

TABLE 2

CARD THICKNESS	"C"
-01	.0310±.0031 [0.787±0.078]
-02	.0620±.0047 [1.575±0.119]

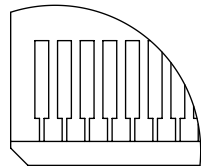
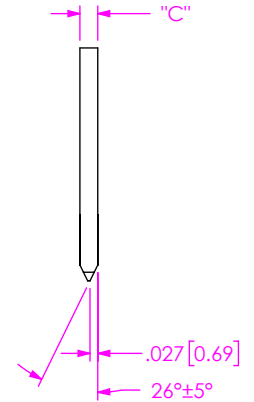
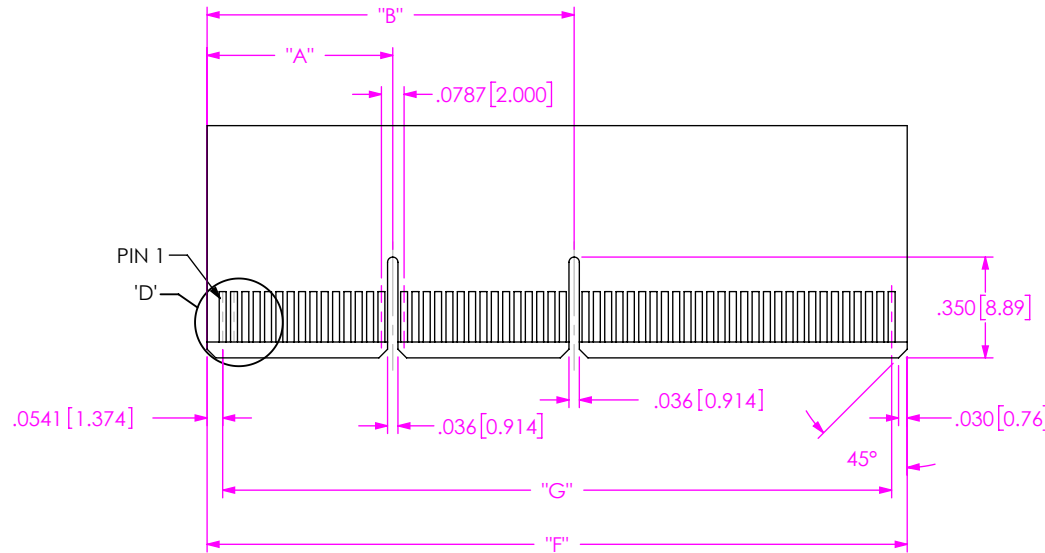
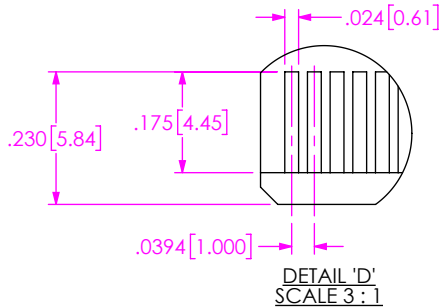

DETAIL 'C'
SCALE 3:1

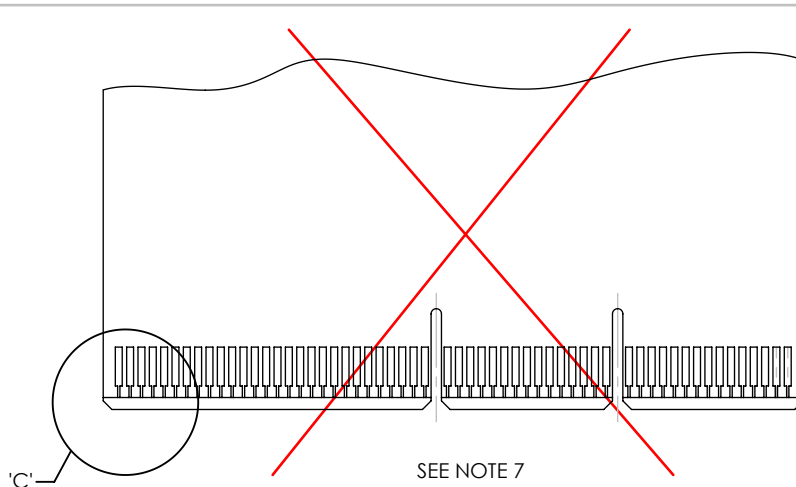

SEE NOTE 7

PROPRIETARY NOTE

THIS DOCUMENT CONTAINS CONFIDENTIAL AND PROPRIETARY INFORMATION AND ALL DESIGN, MANUFACTURING, REPRODUCTION, USE, PATENT RIGHTS AND SALES RIGHTS ARE EXPRESSLY RESERVED BY SAMTEC, INC. THIS DOCUMENT SHALL NOT BE DISCLOSED, IN WHOLE OR PART, TO ANY UNAUTHORIZED PERSON OR ENTITY NOR REPRODUCED, TRANSFERRED OR INCORPORATED IN ANY OTHER PROJECT IN ANY MANNER WITHOUT THE EXPRESS WRITTEN CONSENT OF SAMTEC, INC.



520 PARK EAST BLVD, NEW ALBANY, IN 47150
PHONE: 812-944-6733 FAX: 812-948-5047
e-Mail info@SAMTEC.com code 55322