

REVISIONS			
SYM	ECN, ERN NO.	DATE	APPRD.
H	PER ECN E07102	APR16/07	L.C.
K	PROPOSAL	OCT 30/08	L.C.
L	IMPROVE RETENTION FORCE	MAY10/13	L.C.
M	ADD PULL OUT FORCE SPEC	MAY14/13	L.C.
N	ADD DIM. 0.635	DEC06/13	L.C.

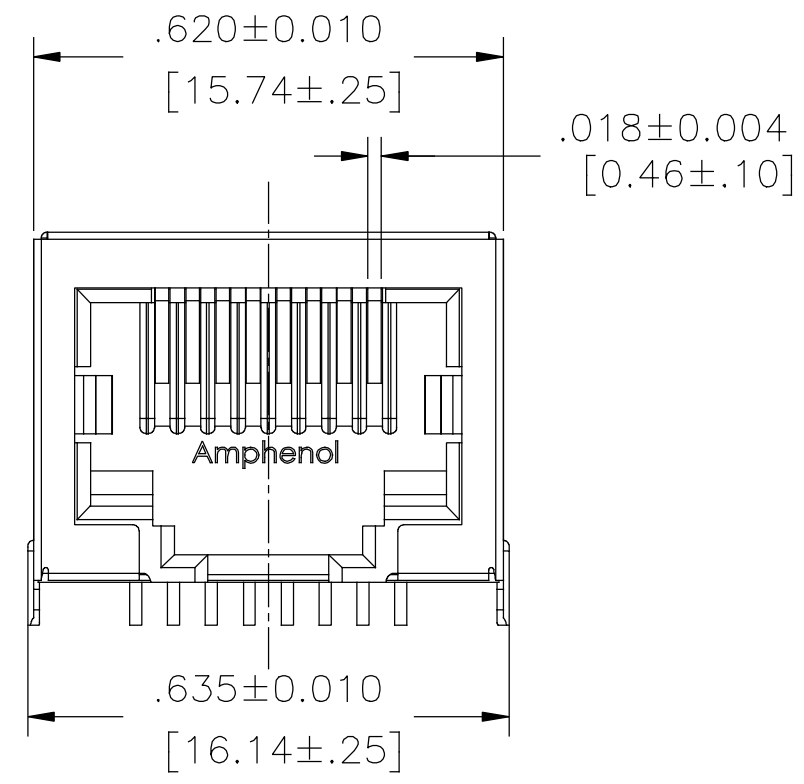

FRONT VIEW

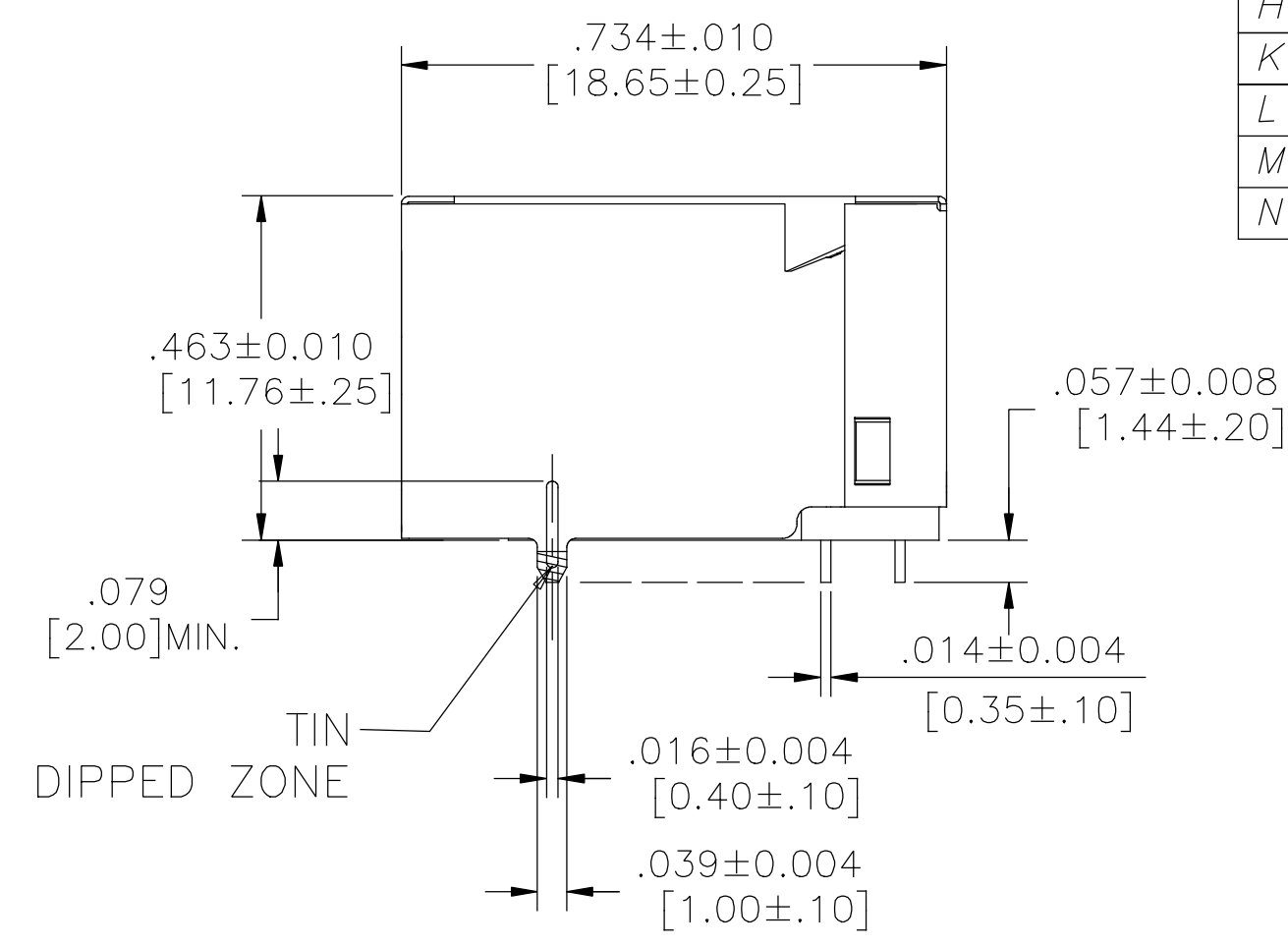

SIDE VIEW

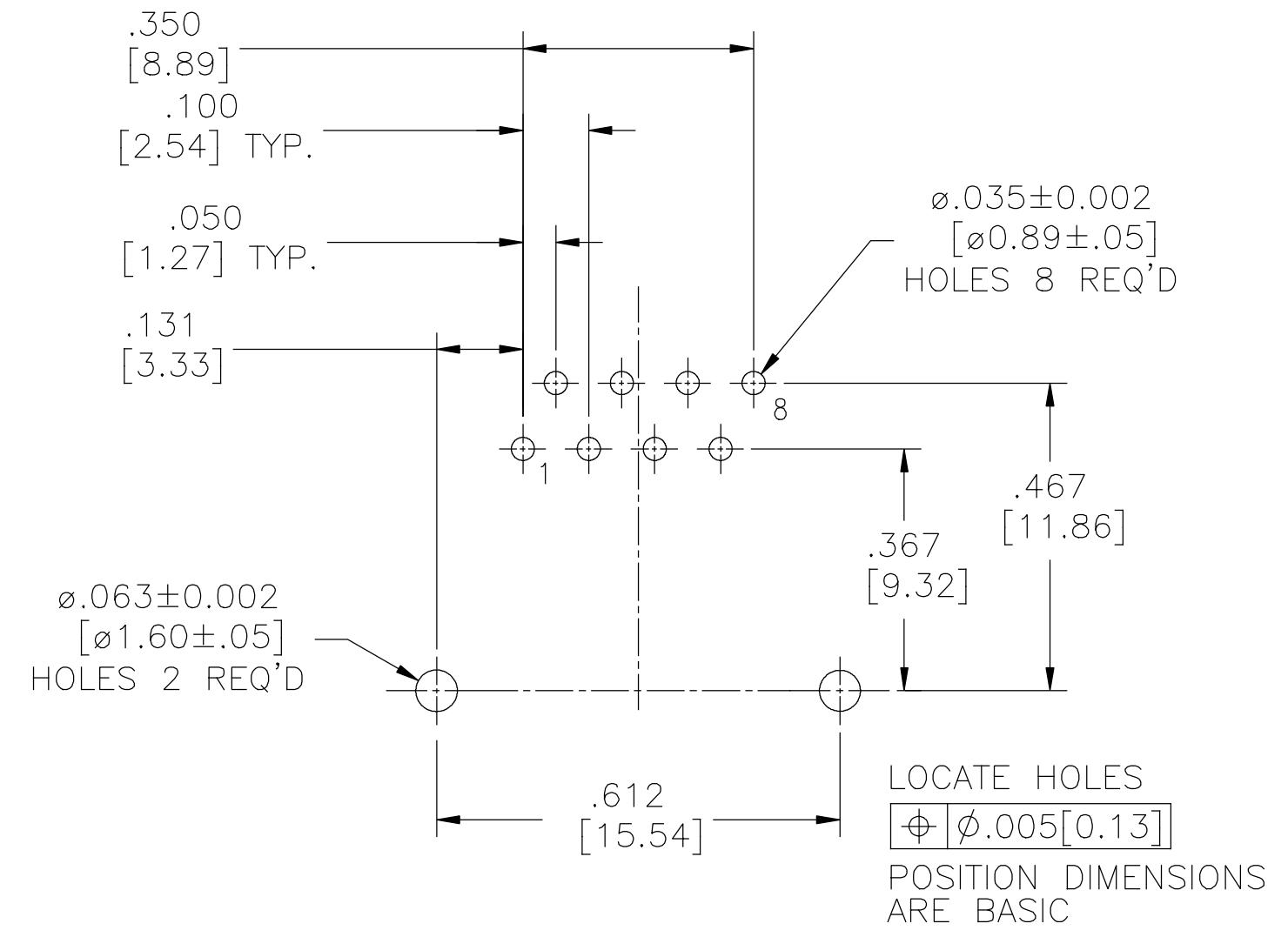

RECOMMENDED P.C.B. LAYOUT  
(COMPONENT SIDE OF BOARD)

**MATERIALS:**  
**HOUSING:** HIGH TEMPERATURE THERMOPLASTIC  
 FLAMMABILITY RATING UL94V-0.  
 COLOR:BLACK  
**CONTACTS:** PHOSPHOR BRONZE  
 PLATING: 50 u" [1.27 MICRONS] GOLD ON MATING SURFACES.  
 50 u" [1.27 MICRONS] MIN. NICKEL UNDERPLATE.  
 100 u" [2.54 MICRONS] MIN. MATTE TIN OR GOLD FLASH ON CONTACT TAILS.  
**SHIELD:** COPPER ALLOY  
 PLATING: NICKEL PLATED WITH TIN DIPPED ON PCB TAIL  
 SUITABLE FOR SOLDERING IN ACCORDANCE WITH JEDEC-020C STANDARD.  
 PULL OUT FORCE FOR PLUG: 20 LBS MIN.

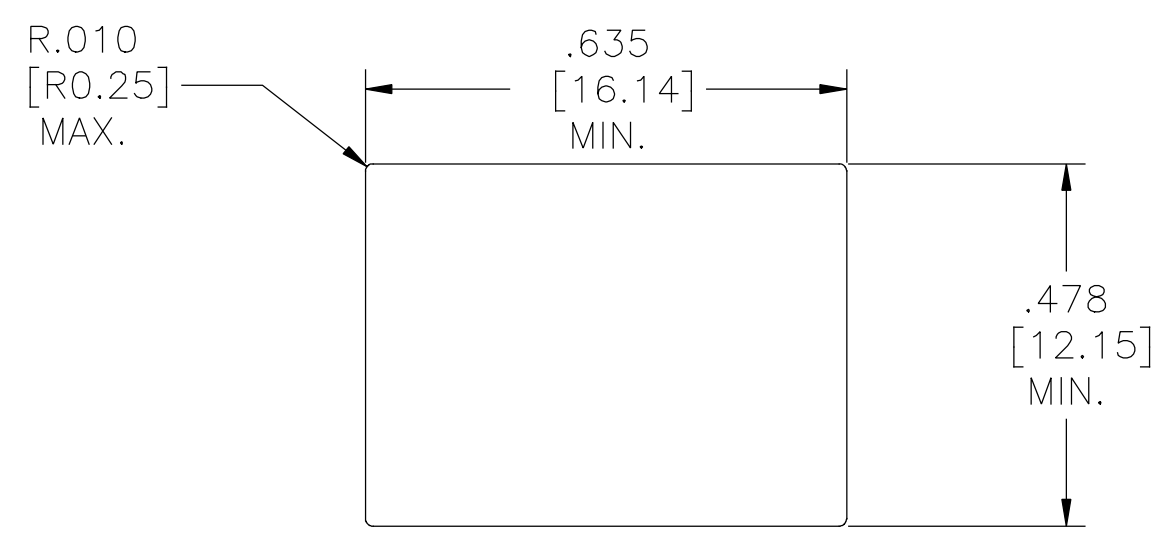

RECOMMENDED PANEL CUTOUT

AMPHENOL PART NUMBER: RJE05-188-1417H

DRAWN	Chigow	DATE	MAY09,06
DESIGNED			
CHECKED	PAULW	DATE	MAY09,06
I. E. APPRD.	YM.LEE	DATE	FEB.27/07
Q. A. APPRD.			
DWG. APPRD.			
ENG. REL. NO.			
REF.			
DIMENSIONS ARE IN	CODE ID. NO.		
INCH[mm]	03554		

<b>Amphenol Canada Corp.</b>			
TITLE RJE05 SERIES MODULAR JACK, 8 POSITIONS, 8 CONTACTS, SHIELDED, HOUSING WITHOUT BOARDLOCK, SEPCIAL TAIL LENGTH .057", ULTRA LOW PROFILE, WITH T & R PACKAGE-RoHS COMPLIANT			
DWG	DRAWING NO.	REV.	
	P-RJE05-188-1417H	N	
SCALE	WT. -----	SURF. -----	SHEET 1 OF 2

THIS DOCUMENT CONTAINS PROPRIETARY INFORMATION AND SUCH INFORMATION MAY NOT BE DISCLOSED TO OTHERS FOR ANY PURPOSE OR USED FOR MANUFACTURING PURPOSES WITHOUT WRITTEN PERMISSION FROM AMPHENOL CANADA CORP.



REVISIONS			
SYM	ECN, ERN NO.	DATE	APPRD.
H	PER ECN E07102	APR16/07	L.C.
K	PROPOSAL	OCT 30/08	L.C.
L	IMPROVE RETENTION FORCE	MAY10/13	L.C.
M	ADD PULL OUT FORCE SPEC	MAY14/13	L.C.
N	ADD DIM. 0.635	DEC06/13	L.C.

← DIRECTION OF CONNECTOR LOADED INTO MACHINE.  
LEADS FACING FRONT SIDE

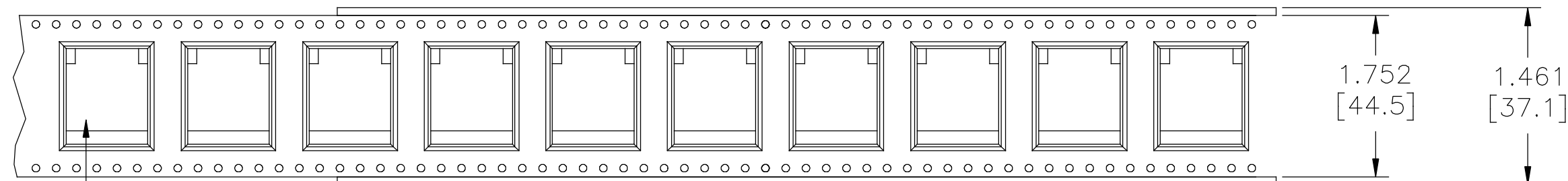

SEE DETAIL 'A' BELOW FOR CARRIER TAPE DETAIL  
TOP VIEW  
(COVER TAPE NOT SHOWN)  
(SHOWN WITH RJE05 8 POSITION CONNECTOR)

PACKAGING NOTES:

- ONE REEL SHOULD HOLD 200 CONNECTORS.
- 25 EMPTY CAVITIES FOR CARRIER TAPE LEADER & 10 EMPTY CAVITIES FOR CARRIER TAPE TRAILER.
- A FULLY LOADED CARTON SHOULD CONTAIN 7 REELS ( PCS) OF CONNECTORS.

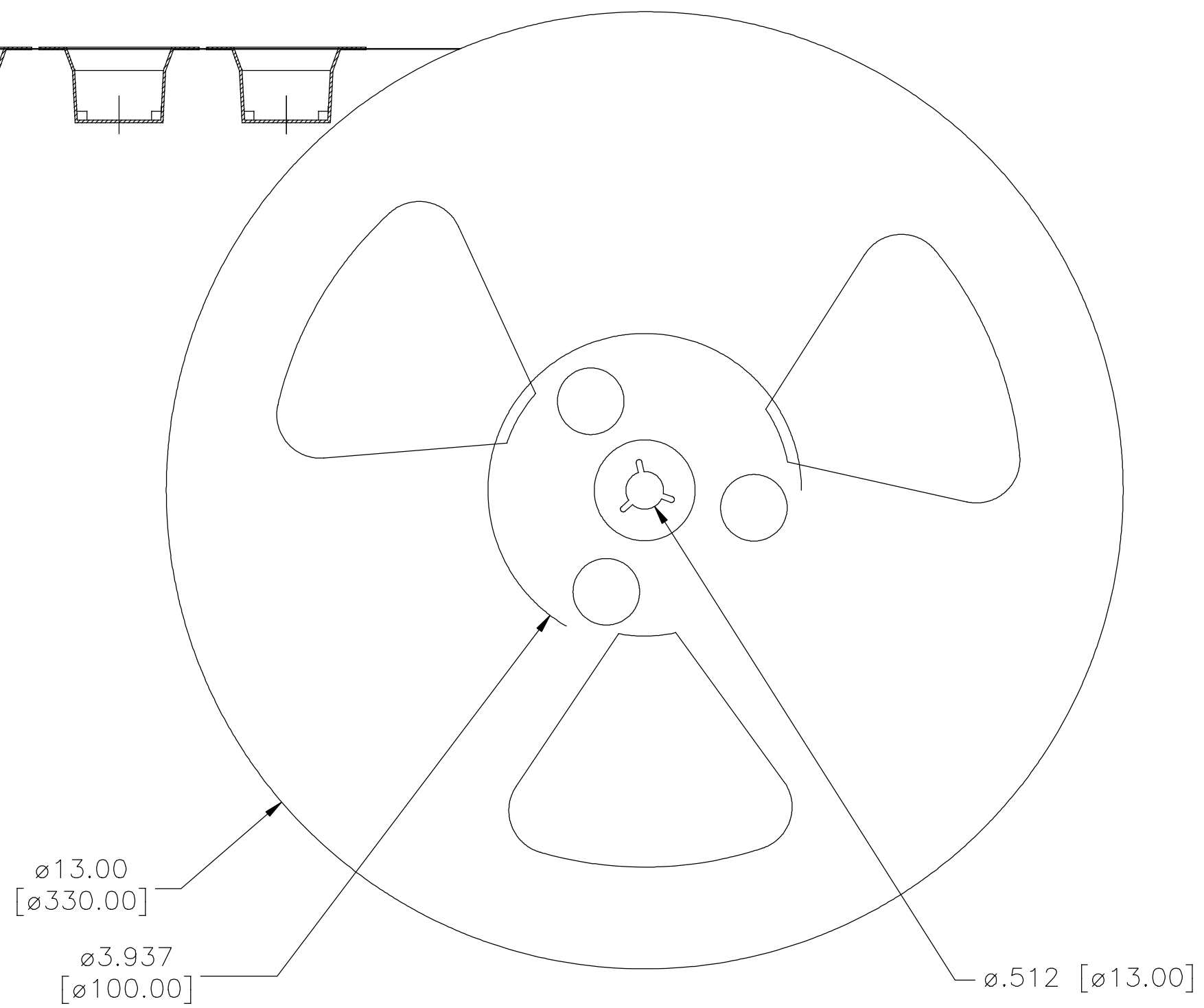
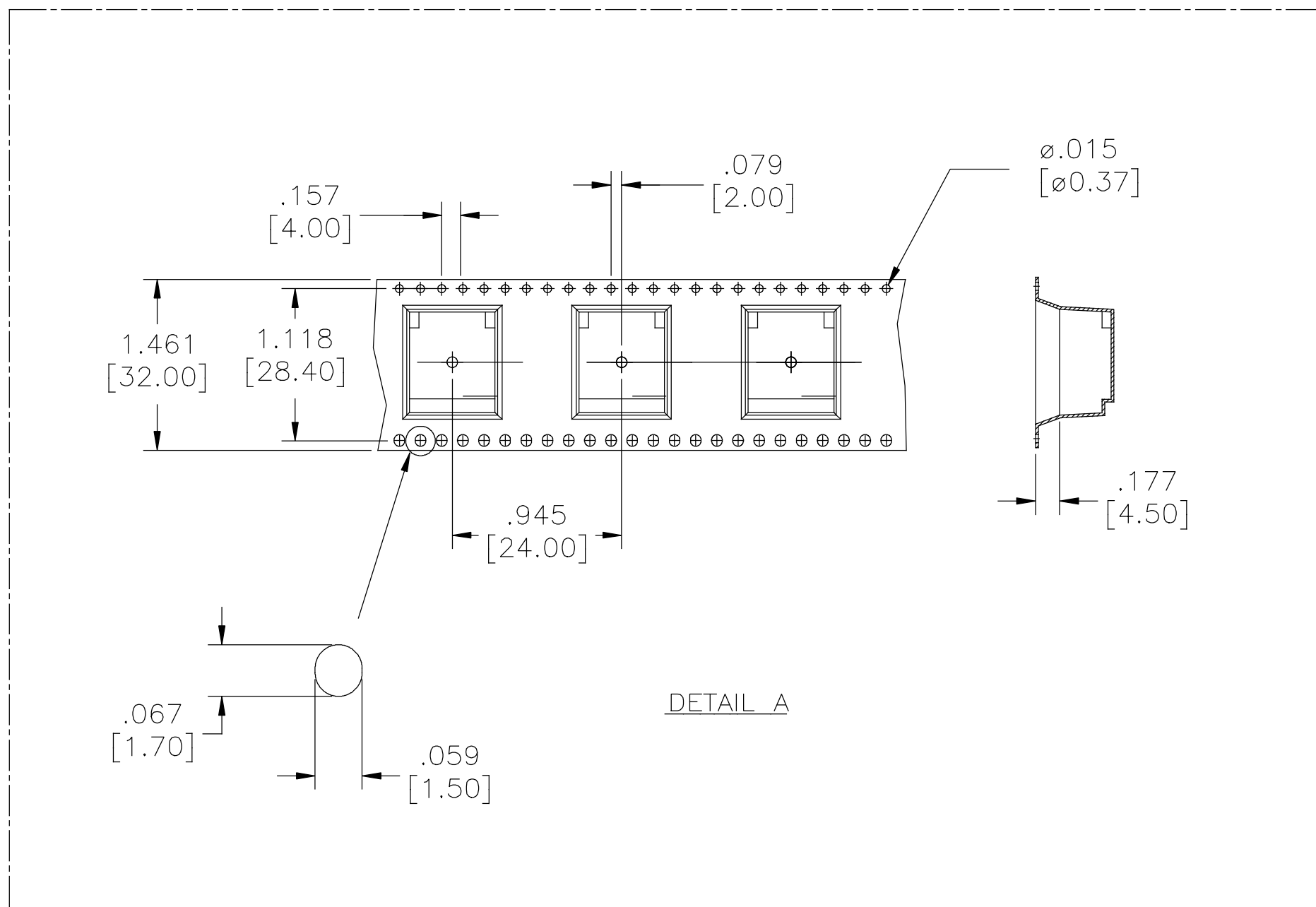
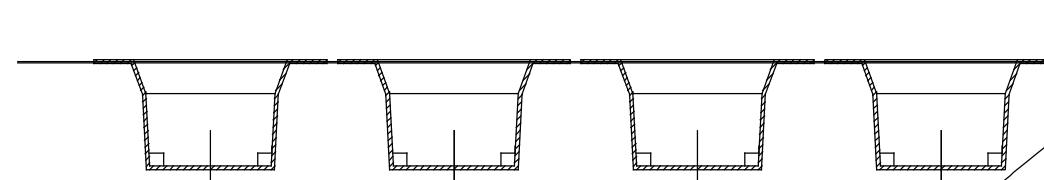

DRAWN	Chigow	DATE	MAY09,06
DESIGNED			
CHECKED	PAULW	DATE	MAY09,06
I. E. APPRD.	YM.LEE	DATE	FEB.27/07
Q. A. APPRD.			
DWG. APPRD.			
ENG. REL. NO.			
REF.			
DIMENSIONS ARE IN	CODE ID. NO.		
INCH[mm]	03554		

Amphenol Canada Corp.

TITLE RJE05 SERIES MODULAR JACK, 8 POSITIONS,  
8 CONTACTS, SHIELDED, HOUSING WITHOUT BOARDLOCK,  
SEPCIAL TAIL LENGHT .057", ULTRA LOW PROFILE,  
,WITH T & R PACKAGE-RoHS COMPLIANT

DWG	DRAWING NO.	REV.
	P-RJE05-188-1417H	N
SCALE	WT. -----	SURF. -----
		SHEET 2 OF 2

THIS DOCUMENT CONTAINS PROPRIETARY INFORMATION AND SUCH INFORMATION MAY NOT BE DISCLOSED TO OTHERS FOR ANY PURPOSE OR USED FOR MANUFACTURING PURPOSES WITHOUT WRITTEN PERMISSION FROM AMPHENOL CANADA CORP.