

NOTES:

RATED VOLTAGE: 3, 4, 5 contacts 250V / 300V
 RATED CURRENT: 3, 4, 5 contacts 4A
 PROTECTION CLASS: IP 68
 TEMPERATURE: -30°C / +80°C

CONTACTS POSITION FRONT VIEW:

	3 CONTACTS		4 CONTACTS		5 CONTACTS		8 CONTACTS	
FEMALE								
MALE								
CONNECTIONS	PIN	WIRE	PIN	WIRE	PIN	WIRE	PIN	WIRE
	1	BROWN	1	BROWN	1	BROWN	1	WHITE
	2	---	2	WHITE	2	WHITE	2	BROWN
	3	BLUE	3	BLUE	3	BLUE	3	GREEN
	4	BLACK	4	BLACK	4	BLACK	4	YELLOW
			5	---	5	GREY OR	5	GREY
							6	PINK
							7	BLUE
							8	RED

FOR OPTIONS SEE - NUMERICAL CODE - ON SHEET 2

ITEM	QTY.	DESCRIPTION	MATERIAL	FINISH
7	1	LABEL YELLOW	VINYL	---
6	3 / 4 / 5	CONTACT MALE	COPPER	SELECTIVE Au OVER Ni
5	1	PLUG U12 MA XP AC STR	-	---
4	-	CABLE	SEE SHEET 2	---
3	-	OVERMOULDING BLACK	TPU	---
2	1	PLUG U12 FE XP AC STR	-	---
1	3 / 4 / 5	CONTACT FEMALE	BRONZE	SELECTIVE Au OVER Ni

FUNCTIONAL SYMBOLS	THIS DRAWING CONTAINS INFORMATION THAT IS PROPRIETARY TO MOLEX ELECTRONIC TECHNOLOGIES, LLC AND SHOULD NOT BE USED WITHOUT WRITTEN PERMISSION	CURRENT REV DESC:		
	DIMENSION UNITS: mm SCALE: 2:1 GENERAL TOLERANCES (UNLESS SPECIFIED): ANGULAR TOL ± 1.0° 4 PLACES ± 3 PLACES ± 2 PLACES ± 0.05 1 PLACE ± 0.3 0 PLACES ± 0.5	EC NO: 698441 DRWN: SSM CHK'D: RSILLER APPR: RSILLER	2021/12/22 2022/03/08 2022/03/08	
DIVISIONAL SYMBOLS	DRAFT WHERE APPLICABLE MUST REMAIN WITHIN DIMENSIONS THIRD ANGLE PROJECTION DRAWING: A3-SIZE SERIES: 120080	INITIAL REVISION: DRWN: AKONDRACIUK APPR: MIWASIECZKO	2016/12/20 2017/03/28	DOCUMENT NUMBER: 1200808027 DOC TYPE: PSD DOC PART: 000 REVISION: A1
		MATERIAL NUMBER: SEE PART LIST	CUSTOMER: GENERAL MARKET	SHEET NUMBER: 1 OF 2

ENGINEERING NO. - NUMERICAL CODE (Available parts see PART LIST table. Other parts available upon request).

OPTIONS

WWXX031XXXXXX

WW=U12x1
Double ended

Contacts:
3=3 Contacts
4=4 Contacts
5=5 Contacts
8=8 Contacts

Heads style:
031=Plug Female 90°
to Plug Male Straight

Cable type: See Table

Units:
M=Meter
C=Centimeter

Length
Examples:
005=0.5 unit
010=1 unit
100=10 units

Overmold color:
Blank (Standard)=Black TPU
A=Grey / G=Black / Y=Yellow
H= 2 pcs. of I/D Carrier PVC Transparent

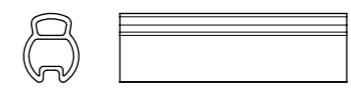

CABLE INFORMATION (for more information see Cable Data Sheet).

CABLE TYPE	NO. OF WIRES	CROSS SECTION	CABLE JACKET	UL	CSA	STATIC: TEMP. / BENDING RADIUS	DYNAMIC: TEMP. / BENDING RADIUS	DRAG CHAIN	SHIELD
H09	3 / 4 / 5	0.34mm ²	PUR BLACK LS0H	UL 21198/10493	C 22.2 I/II A/B 80°C/300V	-40°C to +80°C, 5xO.D.	-25°C to +80°C, 10xO.D.	2 000 000 cycles, Temp max 60°C	-
H08	3 / 4 / 5 / 8	0.25mm ²	PUR BLACK LS0H	UL 21198/10493	C 22.2 I/II A/B 80°C/300V	-40°C to +80°C, 5xO.D.	-25°C to +80°C, 10xO.D.	2 000 000 cycles, Temp max 60°C	-
E03	3 / 4 / 5	0.34mm ²	PVC BLACK	UL 2464/1729	C 22.2 I/II A/B 80°C/300V	-30°C to +80°C, 10xO.D.	-10°C to +80°C, 15xO.D.	-	-
P03	3 / 4 / 5	0.34mm ²	PUR/PVC BLACK	-	-	-30°C to +80°C, 7xO.D.	-5°C to +80°C, 15xO.D.	-	-
P02	3 / 4 / 5 / 8	0.25mm ²	PUR/PVC BLACK	-	-	-30°C to +80°C, 7xO.D.	-5°C to +80°C, 15xO.D.	-	-

PART LIST

MOLEX PN	ENGINEERING No	L [mm]
1200808030	WW3031H09M010	1000
1200808027	WW4031H09M010	1000
1200808153	WW4031E03M010	1000
1200805078	WW5031P03M010	1000
1200808028	WW5031H09M010	1000
1200808056	WW5031P03M015	1500
1200808057	WW5031P03M020	2000
1200808058	WW5031P03M040	4000
1200808059	WW5031P03M045	4500
1200808060	WW5031P03M050	5000
1200808061	WW5031P03M100	10000
1200808074	WW5031P03M020A	2000
1200808075	WW5031P03M050A	5000
1200805084	WW8031P02M010	1000
1200808034	WW8031H08M010	1000

CABLE LENGTH TOLERANCES

OVER	UP TO AND INCLUDING	TOLERANCES
0	305mm	+19mm
305mm	915mm	+45mm
915mm	1830mm	+56mm
1830mm	3660mm	+89mm
3660mm	7320mm	+165mm
7320mm	14640mm	+317mm
14640mm	30500mm	+610mm
30500mm	>	+2% of finished length

FUNCTIONAL SYMBOLS	THIS DRAWING CONTAINS INFORMATION THAT IS PROPRIETARY TO MOLEX ELECTRONIC TECHNOLOGIES, LLC AND SHOULD NOT BE USED WITHOUT WRITTEN PERMISSION
$\nabla_A = 0$ $\nabla_B = 0$ $\nabla_C = 0$	DIMENSION UNITS: mm SCALE: 1:1 GENERAL TOLERANCES (UNLESS SPECIFIED) ANGULAR TOL $\pm 1.0^\circ$ 4 PLACES \pm 3 PLACES \pm 2 PLACES ± 0.05 1 PLACE ± 0.3 0 PLACES ± 0.5
DIVISIONAL SYMBOLS	CURRENT REV DESC: EC NO: 698441 DRWN: SSM CHK'D: RSILLER APPR: RSILLER INITIAL REVISION: DRWN: AKONDRACIUK APPR: MIWASIECZKO
	2021/12/22 2022/03/08 2022/03/08 2016/12/20 2017/03/28
	DOCUMENT NUMBER: 1200808027 DOC TYPE: PSD DOC PART: 000 REVISION: A1
	DRAFT WHERE APPLICABLE MUST REMAIN WITHIN DIMENSIONS THIRD ANGLE PROJECTION DRAWING: A3-SIZE SERIES: 120080 MATERIAL NUMBER: SEE PART LIST CUSTOMER: GENERAL MARKET SHEET NUMBER: 2 OF 2

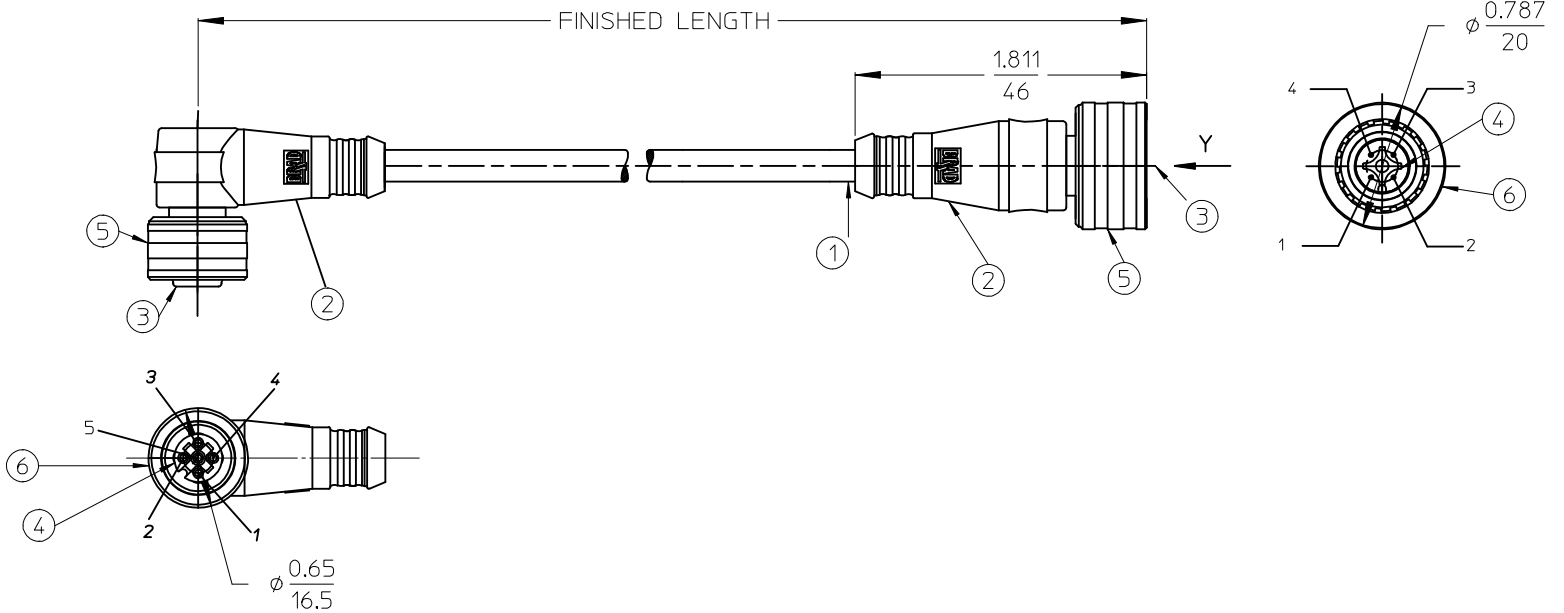

POL	MATERIAL NUMBER	ENGINEERING NUMBER	FINISHED LENGTH
3	1200805061	WW3031P03M010	3.28' +2.19 -0 [1.0M +55.6 -0]
4	1200805067	WW4031P03M010	3.28' +2.19 -0 [1.0M +55.6 -0]
5	1200805078	WW5031P03M010	3.28' +2.19 -0 [1.0M +55.6 -0]

VOLTAGE RATING	300V
AMPERAGE RATING	4A
PROTECTION	IP 67/68/69
OPERATING TEMPERATURE	-25°C / +80 °C
UL CERTIFICATION	FILE NO. E152210
CAS CERTIFICATION	FILE NO. LR6837

ITEM	COMPONENT	MATERIAL	FINISH
6	O-RING	VITON	GREEN
5	SHELL	BRASS	NICKEL PLATED
4	CONTACT	COPPER ALLOY	Au over Ni
3	INSERT	PUR	BLACK
2	OVERMOLD	PUR	BLACK
1	CABLE #22	PUR/PVC	BLACK

ENTER DESCRIPTION
 EC NO: IPG2015-0241
 DRW:WBRAUCH 2014/08/06
 CHKD:
 APPR:CBURGER 2014/08/08
 2

QUALITY SYMBOLS	GENERAL TOLERANCES (UNLESS SPECIFIED)
▽=0	mm INCH
∇=0	4 PLACES ± --- ± ---
	3 PLACES ± --- ± ---
	2 PLACES ± --- ± 0.1
	1 PLACE ± 0.3 ± ---
	0 PLACE ± --- ± ---
	ANGULAR ± --- °
	DRAFT WHERE APPLICABLE MUST REMAIN WITHIN DIMENSIONS

DIMENSION STYLE	
MM ONLY	
DRAWN BY	DATE
APOHL_WEU	2010/02/15
CHECKED BY	DATE
REISSNER	2010/02/16
APPROVED BY	DATE
FPACHER	2010/02/23
MATERIAL NO.	
SEE TABLE	
SIZE	A3

SCALE	DESIGN UNITS	THIRD ANGLE PROJECTION
1:1	METRIC	
TITLE		
CSE U12 XP AC FE RA PUR XP M STR XM		
DOCUMENT NO.		SHEET NO.
SD-120080-045		1 OF 1
THIS DRAWING CONTAINS INFORMATION THAT IS PROPRIETARY TO MOLEX INCORPORATED AND SHOULD NOT BE USED WITHOUT WRITTEN PERMISSION		