

STANDARD EXECUTIONS

- **RH-FG9-11:** ground anodised aluminium, natural colour, semi-matte finish.
- **RH-FG9-14:** ground anodised aluminium, black colour, semi-matte finish.

STATOR AND ROTOR

Chrome-plated zinc alloy.

NUT

Chrome-plated zinc alloy (M19x1).

CLOSING LEVER (TO BE ORDERED SEPARATELY)

Zinc-plated steel, 3 mm thickness. Assembly by means of zinc-plated steel hexagonal nut and spring washer, included in the supply.

TWO KEYS

Nickel-plated brass cylinder, nickel-plated steel handle. Removable in two positions at 90°.

ROTATION

90°.

SPECIAL EXECUTIONS AND ACCESSORIES

Levers in different colours.

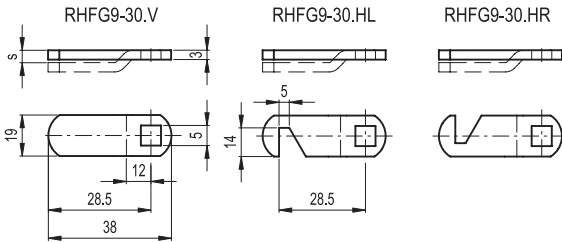

Drilling template

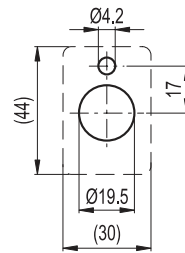

METRIC

Code	l	l1	l2	l3	l4	s	⚖️
RHFG9-30.000.V	13.5	-	-	-	-	-	14
RHFG9-30.000.H	13.5	-	-	-	-	-	14
RHFG9-30.003.V	13.5	16.7	10.3	-	-	3.2	14
RHFG9-30.003.HL	13.5	16.7	10.3	-	-	3.2	14
RHFG9-30.003.HR	13.5	16.7	10.3	-	-	3.2	14
RHFG9-30.006.V	13.5	-	-	19.9	7.1	6.4	14
RHFG9-30.006.HL	13.5	-	-	19.9	7.1	6.4	14
RHFG9-30.006.HR	13.5	-	-	19.9	7.1	6.4	14

Conversion Table	
1 mm = 0.039 inch	
mm	inch
165	6.50

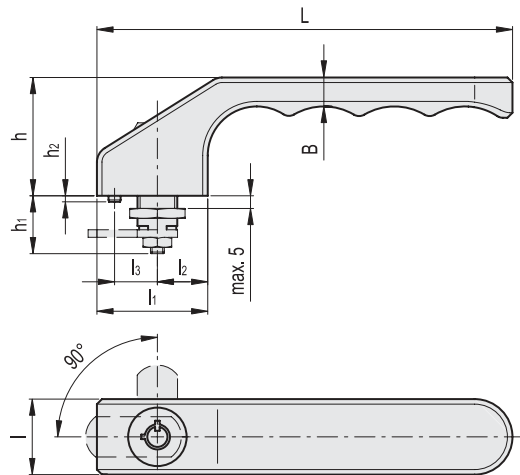
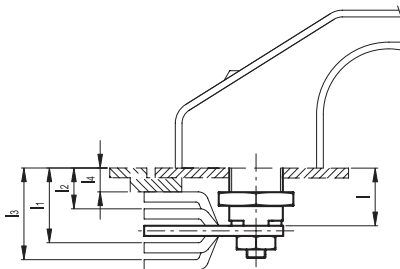

METRIC

Code	L	B	h	h1	h2	l	l1	l2	l3	⚖️
RHFG9-30.165.11	165	11.5	47	23	2	30	44	20	17	228
RHFG9-30.165.14	165	11.5	47	23	2	30	44	20	17	228

