

DMOS driver for bipolar stepper motor

Datasheet – production data

Features

- Operating supply voltage from 8 to 52 V
- 2.8 A output peak current (1.4 A_{r.m.s.})
- R_{DS(on)} 0.73 Ω typ. value @ T_J = 25 °C
- Operating frequency up to 100 kHz
- Non dissipative overcurrent protection
- Dual independent constant t_{OFF} PWM current controllers
- Fast/slow decay mode selection
- Fast decay quasi-synchronous rectification
- Decoding logic for stepper motor full and half-step drive
- Cross conduction protection
- Thermal shutdown
- Undervoltage lockout
- Integrated fast free wheeling diodes

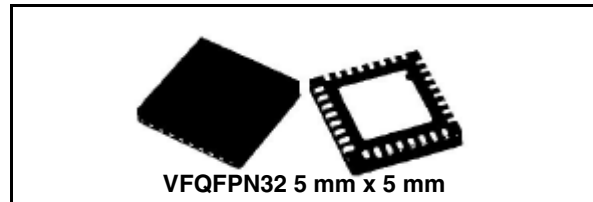

Description

The L6228Q is a DMOS fully integrated stepper motor driver with non-dissipative overcurrent protection, realized in BCD multipower technology, which combines isolated DMOS power transistors with CMOS and bipolar circuits on the same chip. The device includes all the circuitry needed to drive a two-phase bipolar stepper motor including: a dual DMOS full-bridge, the constant off-time PWM current controller that performs the chopping regulation and the phase sequence generator, that generates the stepping sequence. Available in VFQFPN32 5 mm x 5 mm package, the L6228Q features a non-dissipative overcurrent protection on the high-side power MOSFETs and thermal shutdown.

Applications

- Bipolar stepper motor

Figure 1. Block diagram

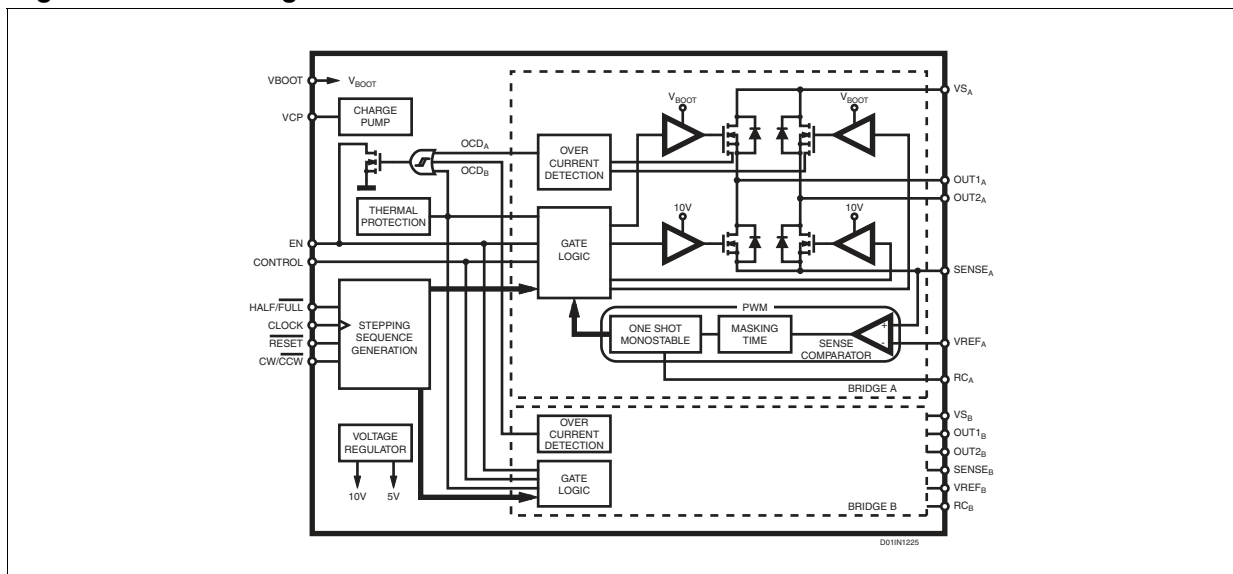

Contents

1	Electrical data	3
1.1	Absolute maximum ratings	3
1.2	Recommended operating conditions	3
1.3	Thermal data	4
2	Pin connection	5
3	Electrical characteristics	7
4	Circuit description	11
4.1	Power stages and charge pump	11
4.2	Logic inputs	12
4.3	PWM current control	13
4.4	Decay modes	16
4.5	Stepping sequence generation	17
4.6	Half-step mode	17
4.7	Normal drive mode (full-step two-phase-on)	18
4.8	Wave drive mode (full-step one-phase-on)	18
4.9	Non-dissipative overcurrent protection	19
4.10	Thermal protection	22
5	Application information	23
6	Output current capability and IC power dissipation	25
7	Thermal management	27
8	Package mechanical data	28
9	Ordering information	30
10	Revision history	31

1 Electrical data

1.1 Absolute maximum ratings

Table 1. Absolute maximum ratings

Symbol	Parameter	Parameter	Value	Unit
V_S	Supply voltage	$V_{SA} = V_{SB} = V_S$	60	V
V_{OD}	Differential voltage between V_{SA} , $OUT1_A$, $OUT2_A$, $SENSE_A$ and V_{SB} , $OUT1_B$, $OUT2_B$, $SENSE_B$	$V_{SA} = V_{SB} = V_S = 60\text{ V}$; $V_{SENSEA} = V_{SENSEB} = \text{GND}$	60	V
V_{BOOT}	Bootstrap peak voltage	$V_{SA} = V_{SB} = V_S$	$V_S + 10$	V
V_{IN}, V_{EN}	Input and enable voltage range		-0.3 to +7	V
V_{REFA}, V_{REFB}	Voltage range at pins V_{REFA} and V_{REFB}		-0.3 to +7	V
V_{RCA}, V_{RCB}	Voltage range at pins RC_A and RC_B		-0.3 to +7	V
V_{SENSEA}, V_{SENSEB}	Voltage range at pins $SENSE_A$ and $SENSE_B$		-1 to +4	V
$I_{S(\text{peak})}$	Pulsed supply current (for each V_S pin), internally limited by the overcurrent protection	$V_{SA} = V_{SB} = V_S$; $t_{PULSE} < 1\text{ ms}$	3.55	A
I_S	RMS supply current (for each V_S pin)	$V_{SA} = V_{SB} = V_S$	1.4	A
T_{stg}, T_{OP}	Storage and operating temperature range		-40 to 150	°C

1.2 Recommended operating conditions

Table 2. Recommended operating conditions

Symbol	Parameter	Parameter	Min.	Max.	Unit
V_S	Supply voltage	$V_{SA} = V_{SB} = V_S$	8	52	V
V_{OD}	Differential voltage between V_{SA} , $OUT1_A$, $OUT2_A$, $SENSE_A$ and V_{SB} , $OUT1_B$, $OUT2_B$, $SENSE_B$	$V_{SA} = V_{SB} = V_S$; $V_{SENSEA} = V_{SENSEB}$		52	V
V_{REFA}, V_{REFB}	Voltage range at pins V_{REFA} and V_{REFB}		-0.1	5	V
V_{SENSEA}, V_{SENSEB}	Voltage range at pins $SENSE_A$ and $SENSE_B$	(pulsed $t_W < t_{tr}$) (DC)	-6 -1	6 1	V V
I_{OUT}	RMS output current			1.4	A
f_{sw}	Switching frequency			100	kHz

1.3 Thermal data

Table 3. Thermal data

Symbol	Parameter	Value	Unit
$R_{th(JA)}$	Thermal resistance junction-ambient ⁽¹⁾	42	°C/W

1. Mounted on a double-layer FR4 PCB with a dissipating copper surface of 0.5 cm² on the top side plus 6 cm² ground layer connected through 18 via holes (9 below the IC).

2 Pin connection

Figure 2. Pin connection (top view)

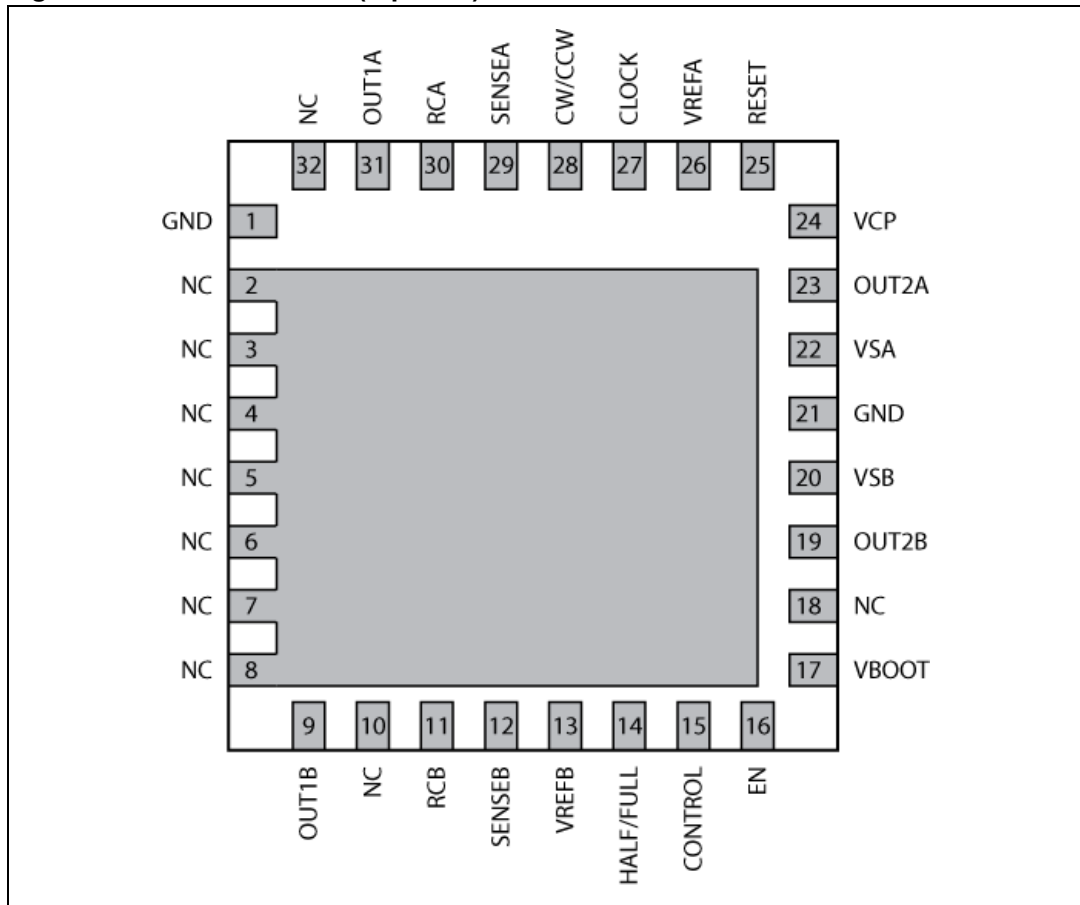

- Note:
- 1 The pins from 2 to 8 are connected to die PAD.
 - 2 The die PAD must be connected to GND pin.

Table 4. Pin description

N°	Pin	Type	Function
1, 21	GND	GND	Ground terminals
9	OUT1 _B	Power output	Bridge B output 1
11	RC _B	RC pin	RC network pin. A parallel RC network connected between this pin and ground sets the current controller off-time of the bridge B.
12	SENSE _B	Power supply	Bridge B source pin. This pin must be connected to power ground through a sensing power resistor.
13	VREF _B	Analog input	Bridge B current controller reference voltage. Do not leave this pin open or connected to GND.
14	HALF/FULL	Logic input	Step mode selector. HIGH logic level sets HALF-STEP mode, LOW logic level sets FULL-STEP mode. If not used, it has to be connected to GND or + 5 V.
15	CONTROL	Logic input	Decay mode selector. HIGH logic level sets SLOW DECAY mode. LOW logic level sets FAST DECAY mode. If not used, it has to be connected to GND or + 5 V.
16	EN	Logic input ⁽¹⁾	Chip enable. LOW logic level switches OFF all power MOSFETs of both bridge A and bridge B. This pin is also connected to the collector of the overcurrent and thermal protection to implement overcurrent protection. If not used, it has to be connected to +5 V through a resistor.
17	VBOOT	Supply voltage	Bootstrap voltage needed to drive the upper power MOSFETs of both bridge A and bridge B.
19	OUT2 _B	Power output	Bridge B output 2.
20	VS _B	Power supply	Bridge B power supply voltage. It must be connected to the supply voltage together with pin VS _A
22	VS _A	Power supply	Bridge A power supply voltage. It must be connected to the supply voltage together with pin VS _B
23	OUT2 _A	Power output	Bridge A output 2.
24	VCP	Output	Charge pump oscillator output.
25	RESET	Logic input	Reset pin. LOW logic level restores the home state (state 1) on the phase sequence generator state machine. If not used, it has to be connected to +5 V.
26	VREF _A	Analog Input	Bridge A current controller reference voltage. Do not leave this pin open or connected to GND.
27	CLOCK	Logic input	Step clock input. The state machine makes one step on each rising edge.
28	CW/CCW	Logic input	Selects the direction of the rotation. HIGH logic level sets clockwise direction, whereas LOW logic level sets counterclockwise direction. If not used, it has to be connected to GND or +5 V.
29	SENSE _A	Power supply	Bridge A source pin. This pin must be connected to power ground through a sensing power resistor.
30	RC _A	RC pin	RC network pin. A parallel RC network connected between this pin and ground sets the current controller off-time of the bridge A.
31	OUT1 _A	Power output	Bridge A output 1

1. Also connected to the output drain of the overcurrent and thermal protection MOSFET. Therefore, it has to be driven putting in series a resistor with a value in the range from 2.2 kΩ to 180 kΩ, recommended 100 kΩ

3 Electrical characteristics

Table 5. Electrical characteristics ($T_A = 25\text{ °C}$, $V_S = 48\text{ V}$, unless otherwise specified)

Symbol	Parameter	Test condition	Min.	Typ.	Max.	Unit
$V_{Sth(ON)}$	Turn-on threshold		5.8	6.3	6.8	V
$V_{Sth(OFF)}$	Turn-off threshold		5	5.5	6	V
I_S	Quiescent supply current	All bridges OFF; $T_J = -25\text{ °C}$ to $125\text{ °C}^{(1)}$		5	10	mA
$T_{j(OFF)}$	Thermal shutdown temperature			165		°C
Output DMOS transistors						
$R_{DS(on)}$	High-side + low-side switch ON resistance	$T_J = 25\text{ °C}$		1.47	1.69	Ω
		$T_J = 125\text{ °C}^{(1)}$		2.35	2.70	Ω
I_{DSS}	Leakage current	EN = Low; OUT = V_S			2	mA
		EN = Low; OUT = GND	-0.3			mA
Source drain diodes						
V_{SD}	Forward ON voltage	$I_{SD} = 1.4\text{ A}$, EN = LOW		1.15	1.3	V
t_{rr}	Reverse recovery time	$I_f = 1.4\text{ A}$		300		ns
t_{fr}	Forward recovery time			200		ns
Logic inputs (EN, CONTROL, HALF/FULL, CLOCK, RESET, CW/CCW)						
V_{IL}	Low level logic input voltage		-0.3		0.8	V
V_{IH}	High level logic input voltage		2		7	V
I_{IL}	Low level logic input current	GND logic input voltage	-10			μA
I_{IH}	High level logic input current	7 V logic input voltage			10	μA
$V_{th(ON)}$	Turn-on input threshold			1.8	2.0	V
$V_{th(OFF)}$	Turn-off input threshold		0.8	1.3		V
$V_{th(HYS)}$	Input threshold hysteresis		0.25	0.5		V
Switching characteristics						
$t_{D(ON)EN}$	Enable to output turn-on delay time ⁽²⁾	$I_{LOAD} = 1.4\text{ A}$, resistive load	500	650	800	ns
$t_{D(OFF)EN}$	Enable to output turn-off delay time ⁽²⁾		500	800	1000	ns
t_{RISE}	Output rise time ⁽²⁾		40		250	ns
t_{FALL}	Output fall time ⁽²⁾		40		250	ns
t_{DCLK}	Clock to output delay time ⁽³⁾			2		μs
$t_{CLK(min)L}$	Minimum clock time ⁽⁴⁾				1	μs
$t_{CLK(min)H}$	Minimum clock time ⁽⁴⁾				1	μs
f_{CLK}	Clock frequency			100	kHz	

Table 5. Electrical characteristics (continued) ($T_A = 25\text{ °C}$, $V_S = 48\text{ V}$, unless otherwise specified)

Symbol	Parameter	Test condition	Min.	Typ.	Max.	Unit
$t_{S(MIN)}$	Minimum set-up time ⁽⁵⁾				1	μs
$t_{H(MIN)}$	Minimum hold time ⁽⁵⁾				1	μs
$t_{R(MIN)}$	Minimum reset time ⁽⁵⁾				1	μs
$t_{RCLK(MIN)}$	Minimum reset to clock delay time ⁽⁵⁾				1	μs
t_{DT}	Dead time protection		0.5	1		μs
f_{CP}	Charge pump frequency	$T_J = -25\text{ °C to }125\text{ °C}^{(1)}$		0.6	1	MHz
PWM comparator and monostable						
I_{RCA}, I_{RCB}	Source current at pins RC_A and RC_B	$V_{RCA} = V_{RCB} = 2.5\text{ V}$	3.5	5.5		mA
V_{offset}	Offset voltage on sense comparator	$V_{REFA}, V_{REFB} = 0.5\text{ V}$		± 5		mV
t_{PROP}	Turn-OFF propagation delay ⁽⁶⁾			500		ns
t_{BLANK}	Internal blanking time on SENSE pins			1		μs
$t_{ON(MIN)}$	Minimum on time			2.5	3	μs
t_{OFF}	PWM recirculation time	$R_{OFF} = 20\text{ k}\Omega; C_{OFF} = 1\text{ nF}$		13		μs
		$R_{OFF} = 100\text{ k}\Omega; C_{OFF} = 1\text{ nF}$		61		μs
I_{BIAS}	Input bias current at pins $VREF_A$ and $VREF_B$				10	μA
Over current protection						
I_{SOVER}	Input supply overcurrent protection threshold	$T_J = -25\text{ °C to }125\text{ °C}^{(1)}$		2.8		A
R_{OPDR}	Open drain ON resistance	$I = 4\text{ mA}$		40	60	W
$t_{OCD(ON)}$	OCD turn-ON delay time ⁽⁷⁾	$I = 4\text{ mA}; C_{EN} < 100\text{ pF}$		200		ns
$t_{OCD(OFF)}$	OCD turn-OFF delay time ⁽⁷⁾	$I = 4\text{ mA}; C_{EN} < 100\text{ pF}$		100		ns

1. Tested at 25 °C in a restricted range and guaranteed by characterization.

2. See [Figure 3](#).

3. See [Figure 4](#).

4. See [Figure 5](#).

5. See [Figure 6](#).

6. Applying a voltage of 1 V to pin SENSE and a voltage drop from 2 V to 0 V to pin VREF.

7. See [Figure 7](#).

Figure 3. Switching characteristic definition

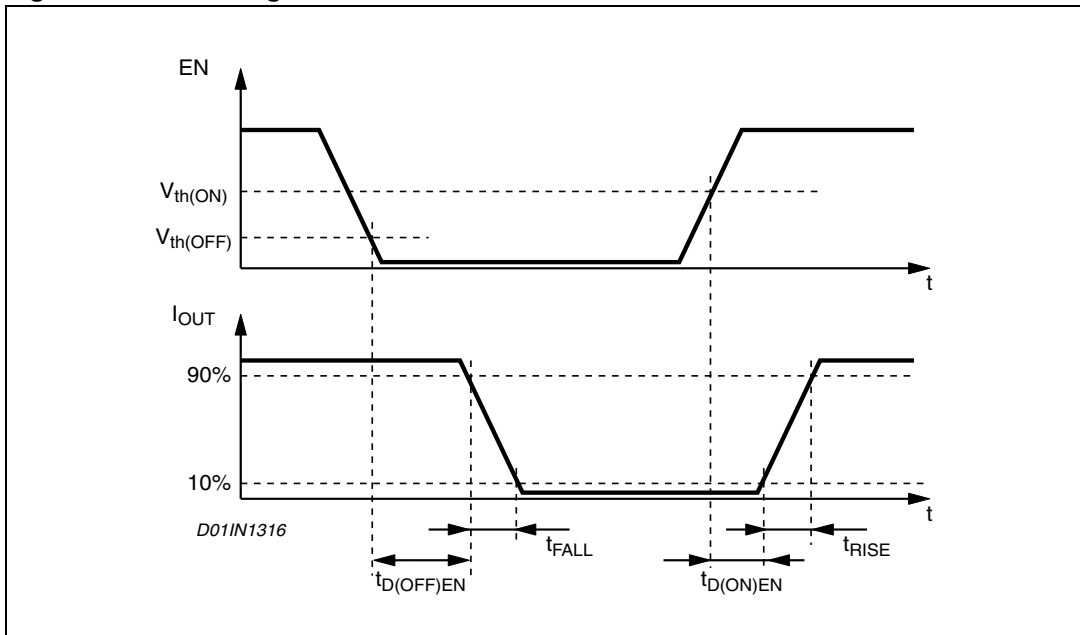

Figure 4. Clock to output delay time

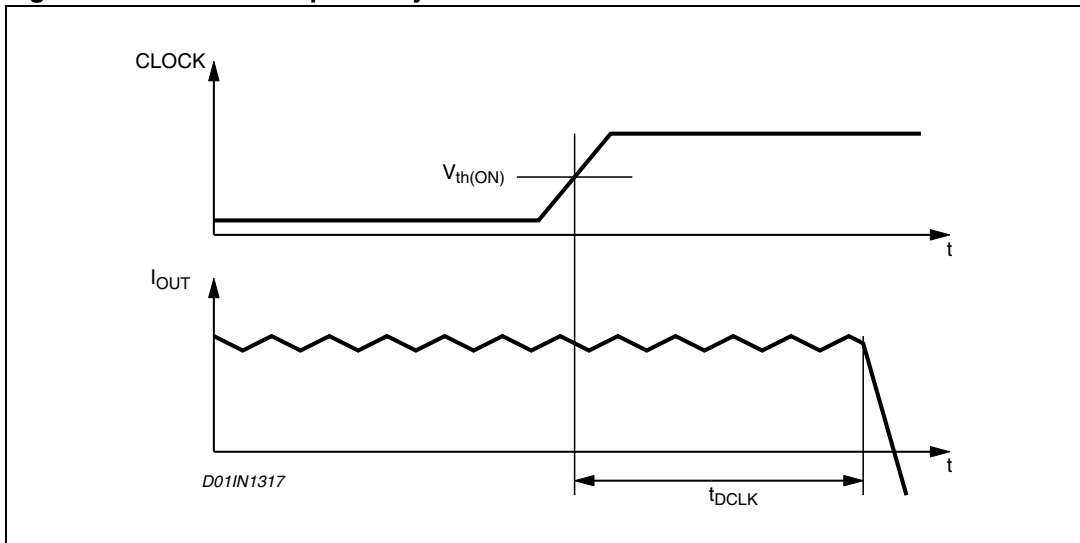

Figure 5. Minimum timing definition - clock input

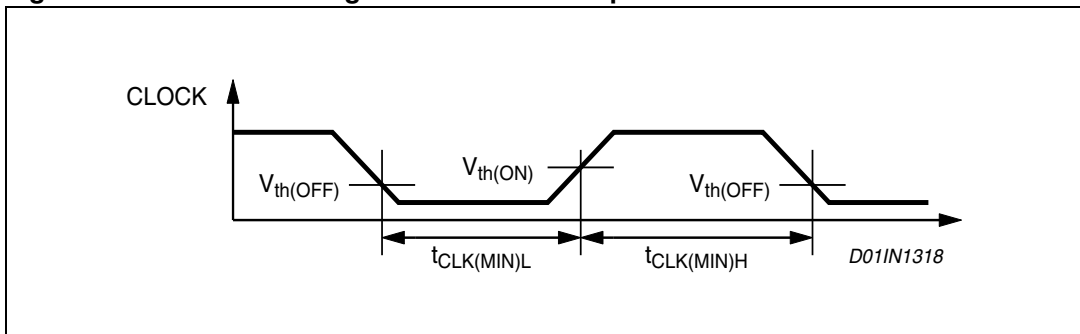

Figure 6. Minimum timing definition - logic inputs

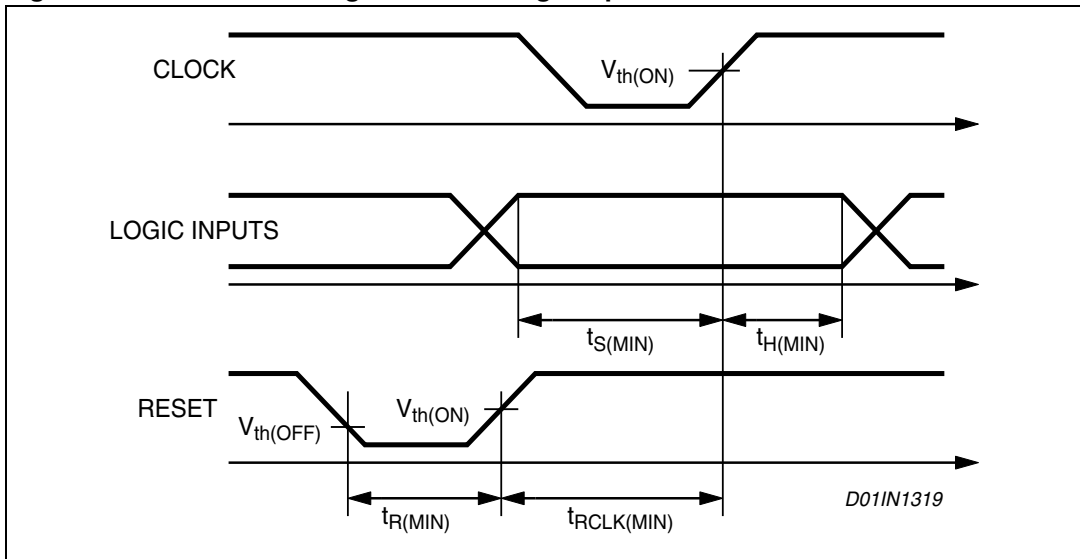
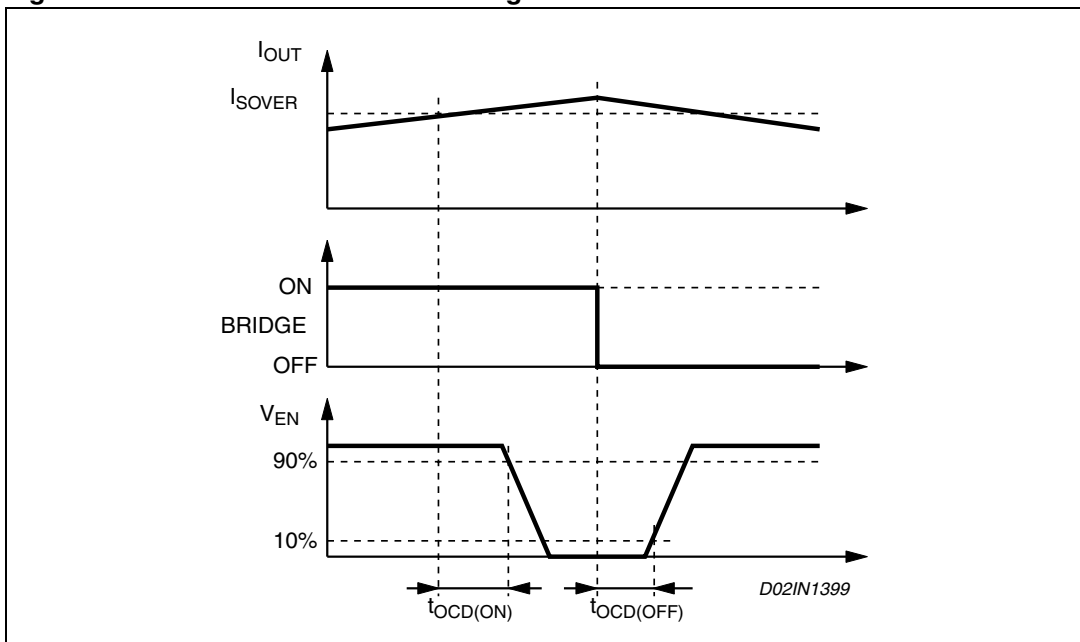

Figure 7. Overcurrent detection timing definition



4 Circuit description

4.1 Power stages and charge pump

The L6228Q integrates two independent power MOSFET full-bridges. Each power MOSFET has an $R_{DS(on)} = 0.73 \Omega$ (typical value @ 25 °C), with intrinsic fast freewheeling diode. Switching patterns are generated by the PWM current controller and the phase sequence generator (see below). Cross conduction protection is achieved using a dead time ($t_{DT} = 1 \mu s$ typical value) between the switch off and switch on of two power MOSFETs in one leg of a bridge.

V_{SA} and V_{SB} pins must be connected together to the supply voltage V_S . The device operates with a supply voltage in the range from 8 V to 52 V. It has to be noticed that the $R_{DS(on)}$ increases of some percents when the supply voltage is in the range from 8 V to 12 V.

Using N-channel power MOSFETs for the upper transistors in the bridge requires a gate drive voltage above the power supply voltage. The bootstrapped supply voltage V_{BOOT} is obtained through an internal oscillator and few external components to realize a charge pump circuit as shown in [Figure 8](#). The oscillator output (VCP) is a square wave at 600 kHz (typical) with 10 V amplitude. Recommended values/part numbers for the charge pump circuit are shown in [Table 6](#).

Table 6. Charge pump external component values

Component	Value
C_{BOOT}	220 nF
C_P	10 nF
D1	1N4148
D2	1N4148

Figure 8. Charge pump circuit

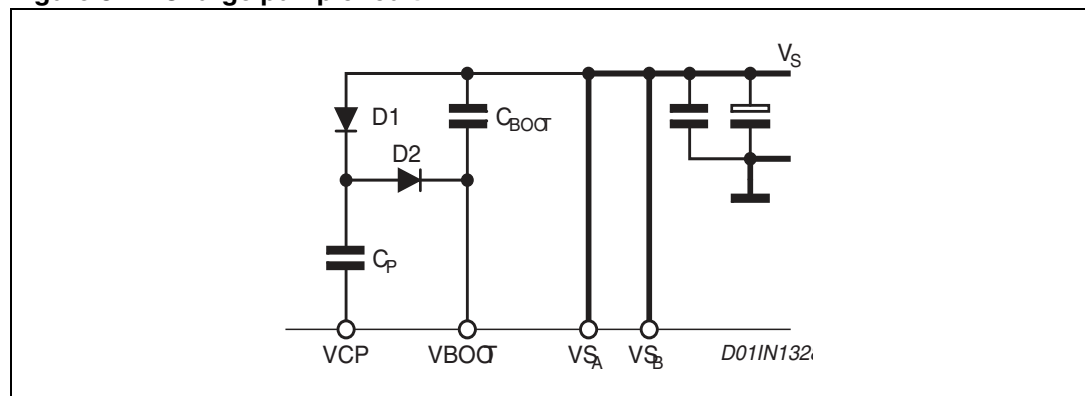

4.2 Logic inputs

Pins CONTROL, HALF/FULL, CLOCK, RESET and CW/CCW are TTL/CMOS and microcontroller compatible logic inputs. The internal structure is shown in [Figure 9](#). Turn-on and turn-off threshold typical values are respectively $V_{th(ON)} = 1.8\text{ V}$ and $V_{th(OFF)} = 1.3\text{ V}$.

Pin EN (Enable) has identical input structure with the exception that the drain of the overcurrent and thermal protection MOSFET is also connected to this pin. Due to this connection, this pin has to be driven carefully. The EN input may be driven in one of two configurations as shown in [Figure 10](#) or [Figure 11](#). If driven by an open drain (collector) structure, a pull-up resistor R_{EN} and a capacitor C_{EN} are connected as shown in [Figure 10](#). If the driver is a standard Push-Pull structure the resistor R_{EN} and the capacitor C_{EN} are connected as shown in [Figure 11](#). The resistor R_{EN} should be chosen in the range from 2.2 kΩ to 180 kΩ. R_{EN} and C_{EN} recommended values are respectively 100 kΩ and 5.6 nF.

Figure 9. Logic input internal structure

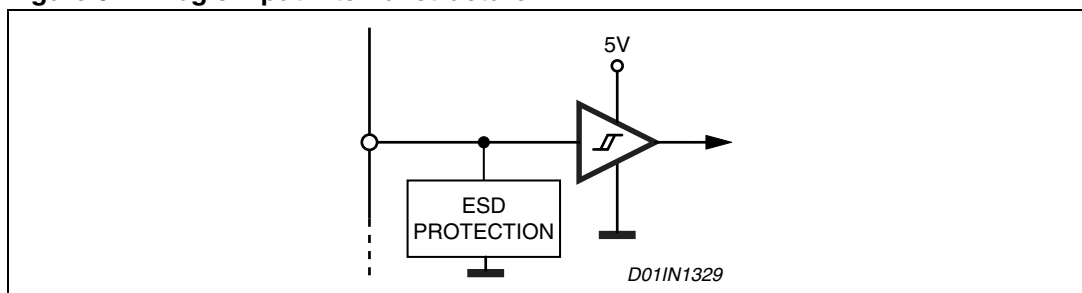

Figure 10. EN pin open collector driving

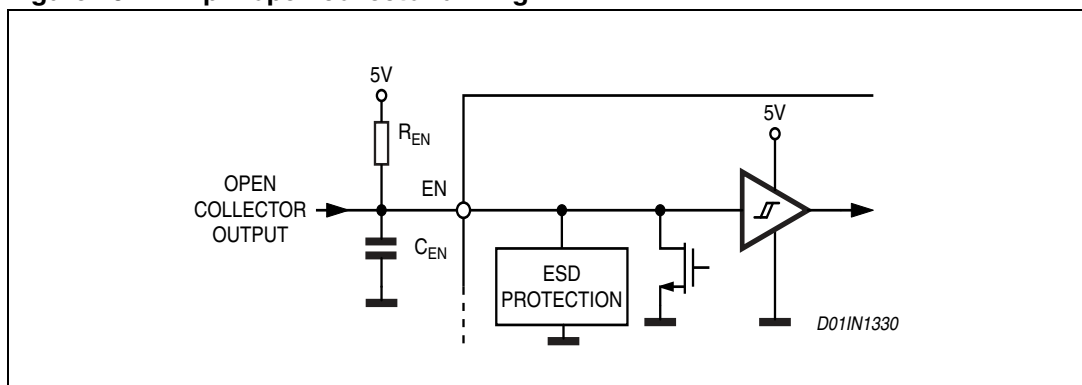
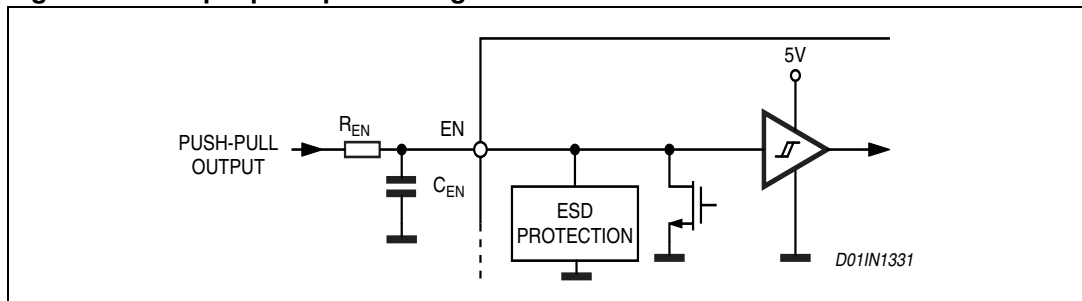

Figure 11. EN pin push-pull driving



4.3 PWM current control

The L6228Q includes a constant off-time PWM current controller for each of the two bridges. The current control circuit senses the bridge current, by monitoring the voltage drop across an external sense resistor connected between the source of the two lower power MOSFET transistors and ground, as shown in *Figure 12*. As the current in the motor builds up the voltage across the sense resistor increases proportionally. When the voltage drop across the sense resistor becomes greater than the voltage at the reference input ($VREF_A$ or $VREF_B$) the sense comparator triggers the monostable switching the bridge off. The power MOSFETs remain off for the time set by the monostable and the motor current recirculates as defined by the selected decay mode, described in the next section. When the monostable times out, the bridge turns on again. Since the internal dead time, used to prevent cross conduction in the bridge, delays the turn-on of the power MOSFET, the effective off-time is the sum of the monostable time plus the dead time.

Figure 12. PWM current controller simplified schematic

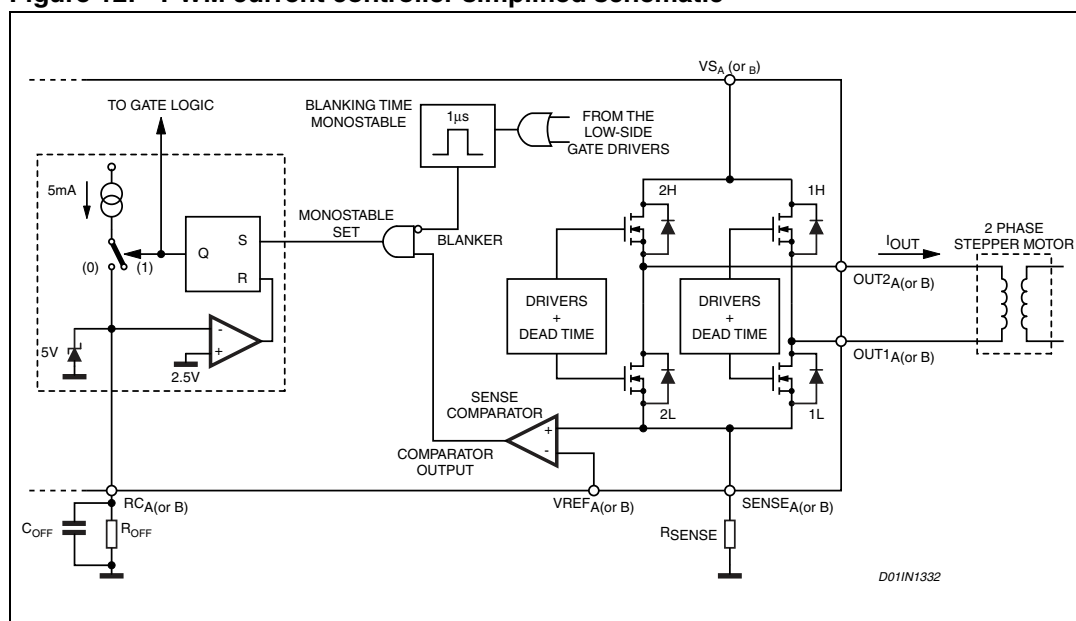

Figure 13 shows the typical operating waveforms of the output current, the voltage drop across the sensing resistor, the RC pin voltage and the status of the bridge. More details regarding the synchronous rectification and the output stage configuration are included in the next section.

Immediately after the power MOSFET turns on, a high peak current flows through the sensing resistor due to the reverse recovery of the freewheeling diodes. The L6228Q provides a 1 µs blanking time t_{BLANK} that inhibits the comparator output so that this current spike cannot prematurely re-trigger the monostable.

Figure 13. Output current regulation waveforms

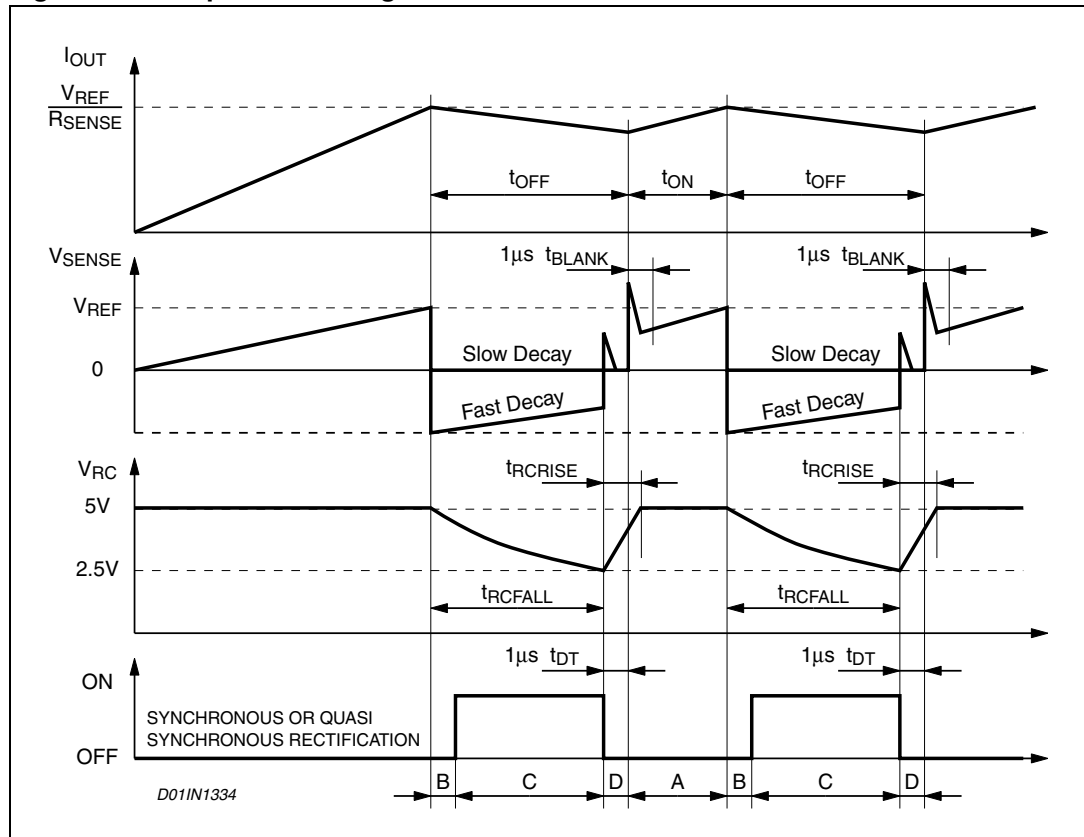

Figure 14 shows the magnitude of the off-time t_{OFF} versus C_{OFF} and R_{OFF} values. It can be approximately calculated from the equations:

$$t_{RCFALL} = 0.6 \cdot R_{OFF} \cdot C_{OFF}$$

$$t_{OFF} = t_{RCFALL} + t_{DT} = 0.6 \cdot R_{OFF} \cdot C_{OFF} + t_{DT}$$

where R_{OFF} and C_{OFF} are the external component values and t_{DT} is the internally generated Dead Time with:

$$20 \text{ k}\Omega \leq R_{OFF} \leq 100 \text{ k}\Omega$$

$$0.47 \text{ nF} \leq C_{OFF} \leq 100 \text{ nF}$$

$$t_{DT} = 1 \text{ }\mu\text{s (typical value)}$$

Therefore:

$$t_{OFF(MIN)} = 6.6 \text{ }\mu\text{s}$$

$$t_{OFF(MAX)} = 6 \text{ ms}$$

These values allow a sufficient range of t_{OFF} to implement the drive circuit for most motors.

The capacitor value chosen for C_{OFF} also affects the rise time t_{RCRISE} of the voltage at the pin RCOFF. The rise time t_{RCRISE} can be an issue if the capacitor is not completely charged before than the next time the monostable is triggered. Therefore, the on time t_{ON} , which depends on motors and supply parameters, has to be bigger than t_{RCRISE} to allow a good current regulation by the PWM stage. Furthermore, the on time t_{ON} can not be smaller than the minimum on time $t_{ON(MIN)}$.

$$\begin{cases} t_{ON} > t_{ON(MIN)} = 2.5\mu\text{s} & (\text{typ. value}) \\ t_{ON} > t_{RCRISE} - t_{DT} \end{cases}$$

$$t_{RCRISE} = 600 \cdot C_{OFF}$$

Figure 15 shows the lower limit for the on time t_{ON} to get a good PWM current regulation capacity. It has to be said that t_{ON} is always bigger than $t_{ON(MIN)}$ because the device imposes this condition, but it can be smaller than $t_{RCRISE} - t_{DT}$. In this last case the device continues working but the off-time t_{OFF} is not more constant.

So, small C_{OFF} value gives more flexibility for the applications (allows smaller on time and, therefore, higher switching frequency), but, the smaller the value for C_{OFF} , the more influential the noises on the circuit performance.

Figure 14. t_{OFF} versus C_{OFF} and R_{OFF}

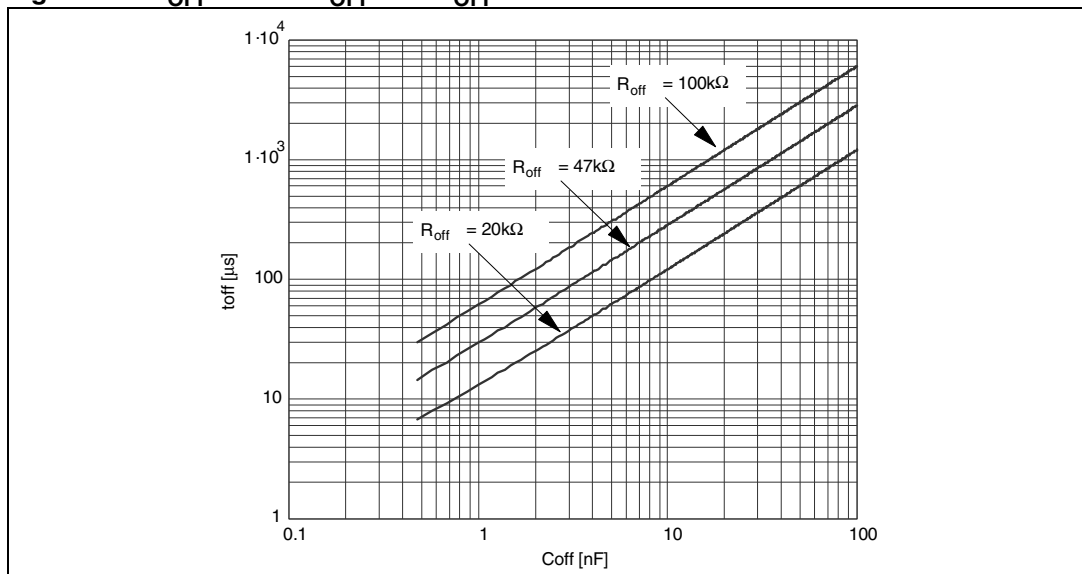
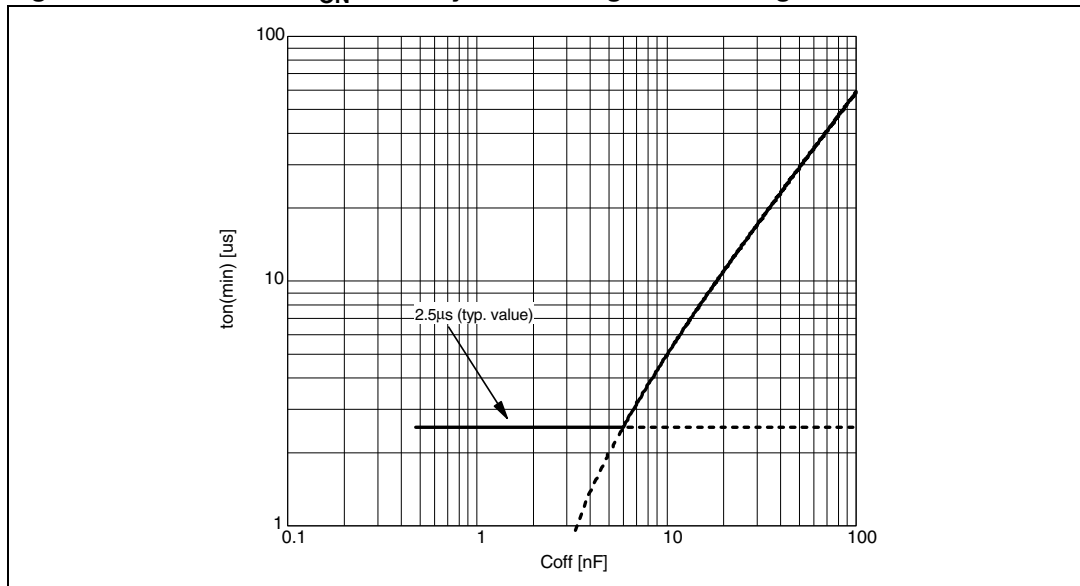

Figure 15. Area where t_{ON} can vary maintaining the PWM regulation

4.4 Decay modes

The CONTROL input is used to select the behavior of the bridge during the off-time. When the CONTROL pin is low, the fast decay mode is selected and both transistors in the bridge are switched off during the off-time. When the CONTROL pin is high, the slow decay mode is selected and only the low-side transistor of the bridge is switched off during the off-time.

Figure 16 shows the operation of the bridge in the fast decay mode. At the start of the off-time, both of the power MOSFETs are switched off and the current recirculates through the two opposite free wheeling diodes. The current decays with a high di/dt since the voltage across the coil is essentially the power supply voltage. After the dead time, the lower power MOSFET, in parallel with the conducting diode, is turned on in synchronous rectification mode. In applications where the motor current is low, it is possible for the current to decay completely to zero during the off-time. At this point, if both of the power MOSFETs were operating in the synchronous rectification mode it would be possible for the current to build in the opposite direction. To prevent this, the lower power MOSFET is operated in synchronous rectification mode only. This operation is called quasi-synchronous rectification mode. When the monostable times out, the power MOSFETs are turned on again after some delay set by the dead time to prevent cross conduction.

Figure 17 shows the operation of the bridge in the slow decay mode. At the start of the off-time, the lower power MOSFET is switched off and the current recirculates around the upper half of the bridge. Since the voltage across the coil is low, the current decays slowly. After the dead time, the upper power MOSFET is operated in the synchronous rectification mode. When the monostable times out, the lower power MOSFET is turned on again after some delay set by the dead time to prevent cross conduction.

Figure 16. Fast decay mode output stage configurations

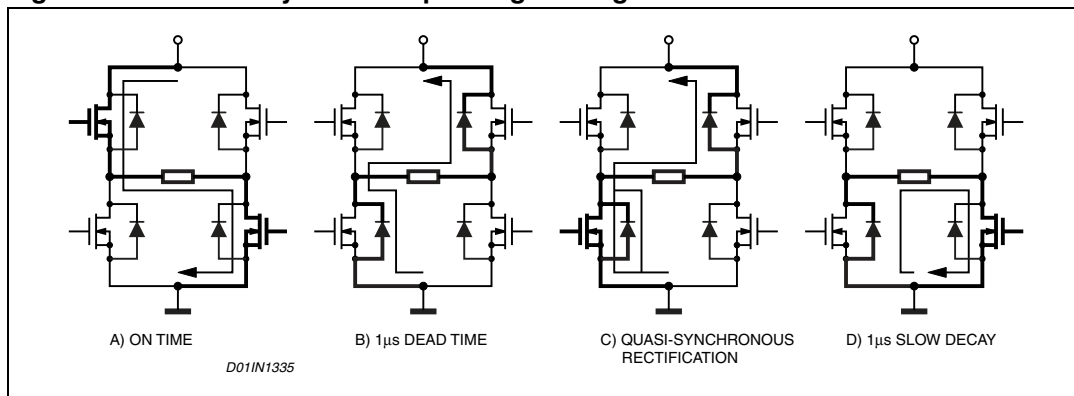
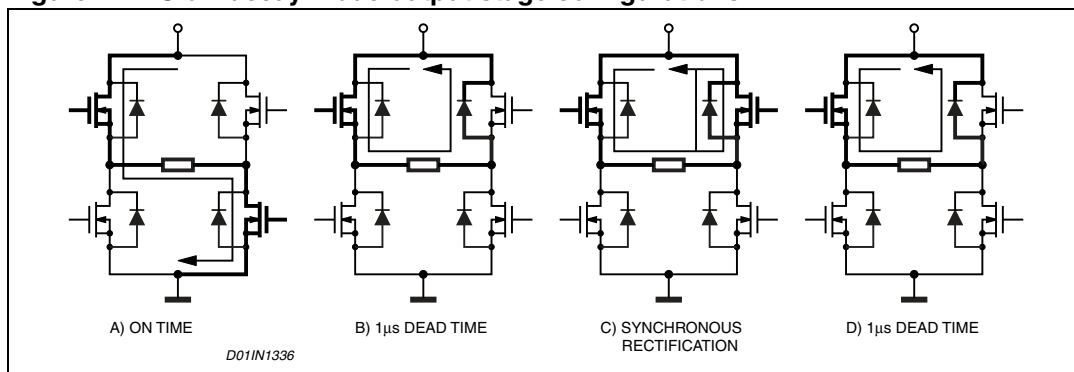

Figure 17. Slow decay mode output stage configurations



4.5 Stepping sequence generation

The phase sequence generator is a state machine that provides the phase and enable inputs for the two bridges to drive a stepper motor in either full-step or half-step. Two full-step modes are possible, the normal drive mode where both phases are energized each step and the wave drive mode where only one phase is energized at a time. The drive mode is selected by the HALF/FULL input and the current state of the sequence generator as described below. A rising edge of the CLOCK input advances the state machine to the next state. The direction of rotation is set by the CW/CCW input. The RESET input resets the state machine to state 1.

4.5.1 Half-step mode

A high logic level on the HALF/FULL input selects half-step mode. *Figure 18* shows the motor current waveforms and the state diagram for the phase sequencer generator. At startup or after a RESET the phase sequencer is at state 1. After each clock pulse the state changes following the sequence 1,2,3,4,5,6,7,8,... if CW/CCW is high (clockwise movement) or 1,8,7,6,5,4,3,2,... if CW/CCW is low (counterclockwise movement).

4.5.2 Normal drive mode (full-step two-phase-on)

A low level on the HALF/FULL input selects the full-step mode. The normal drive mode is selected if the low level is applied when the state machine is at an ODD state. *Figure 19* shows the motor current waveform state diagram for the state machine of the phase sequencer generator. The normal drive mode can easily be selected by holding the HALF/FULL input low and applying a RESET. At startup or after a RESET the state machine is in state 1. While the HALF/FULL input is kept low, the state changes following the sequence 1,3,5,7,... if CW/CCW is high (clockwise movement) or 1,7,5,3,... if CW/CCW is low (counterclockwise movement).

4.5.3 Wave drive mode (full-step one-phase-on)

A low level on the pin HALF/FULL input selects the full-step mode. The wave drive mode is selected if the low level is applied when the state machine is at an EVEN state. *Figure 20* shows the motor current waveform and the state diagram for the state machine of the phase sequence generator. To enter the wave drive mode, the state machine must be in an EVEN numbered state. The most direct method to select the wave drive mode is to apply a RESET first, then while keeping the HALF/FULL input high, applying one pulse to the clock input, then taking the HALF/FULL input low. This sequence forces the state machine to state 1. The clock pulse, with the HALF/FULL input high, advances the state machine from state 1 to either state 2 or 8 depending on the CW/CCW input. Starting from this point, after each clock pulse (rising edge) advances the state machine following the sequence 2,4,6,8,... if CW/CCW is high (clockwise movement) or 8,6,4,2,... if CW/CCW is low (counterclockwise movement).

Figure 18. Half-step mode

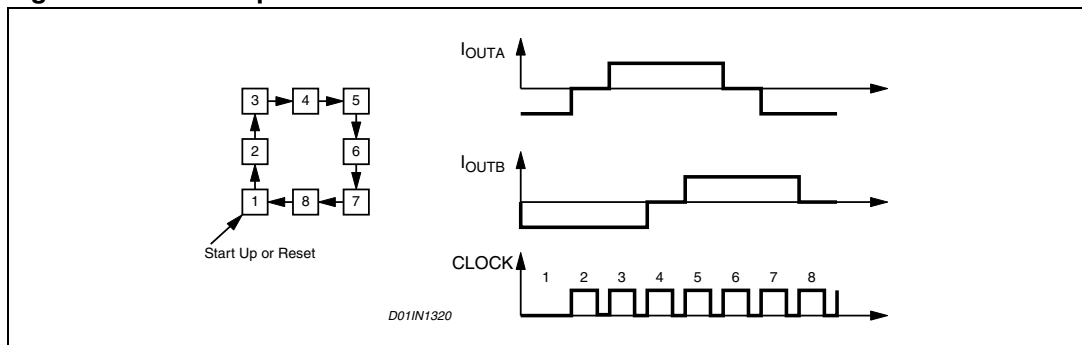

Figure 19. Normal drive mode

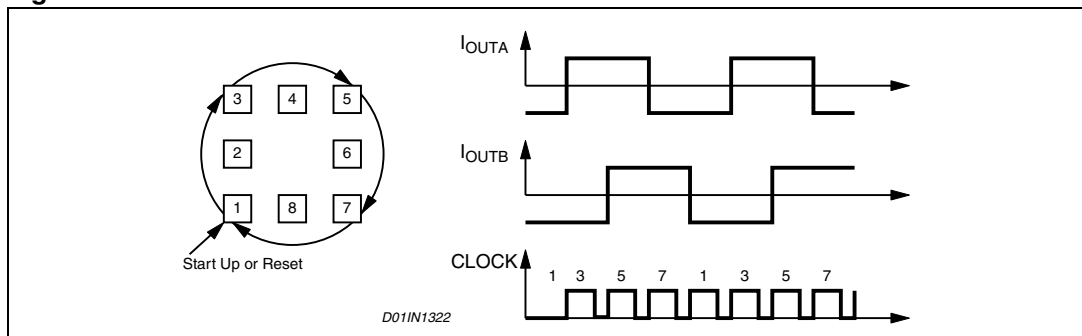
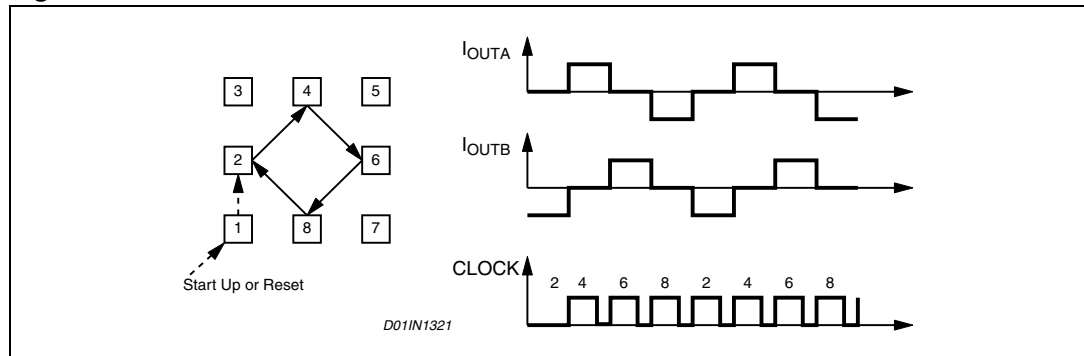

Figure 20. Wave drive mode



4.6 Non-dissipative overcurrent protection

The L6228Q integrates an overcurrent detection circuit (OCD) for full protection. This circuit provides protection against a short-circuit to ground or between two phases of the bridge. With this internal overcurrent detection, the external current sense resistor normally used and its associated power dissipation are eliminated. [Figure 21](#) shows a simplified schematic of the overcurrent detection circuit.

To implement the overcurrent detection, a sensing element delivering a small but precise fraction of each high-side MOSFET current is integrated. Since this current is a small fraction of the output current there is very little additional power dissipation. This current is compared with an internal reference current I_{REF} . When the output current reaches the detection threshold (typically 2.8 A) the OCD comparator signals a fault condition. When a fault condition is detected, the EN pin is pulled below the turn-off threshold (1.3 V typical) by an internal open drain MOSFET with a pull down capability of 4 mA. By using an external R-C on the EN pin, the off-time before recovering normal operation can be easily programmed by means of the accurate thresholds of the logic inputs.

Figure 21. Overcurrent protection simplified schematic

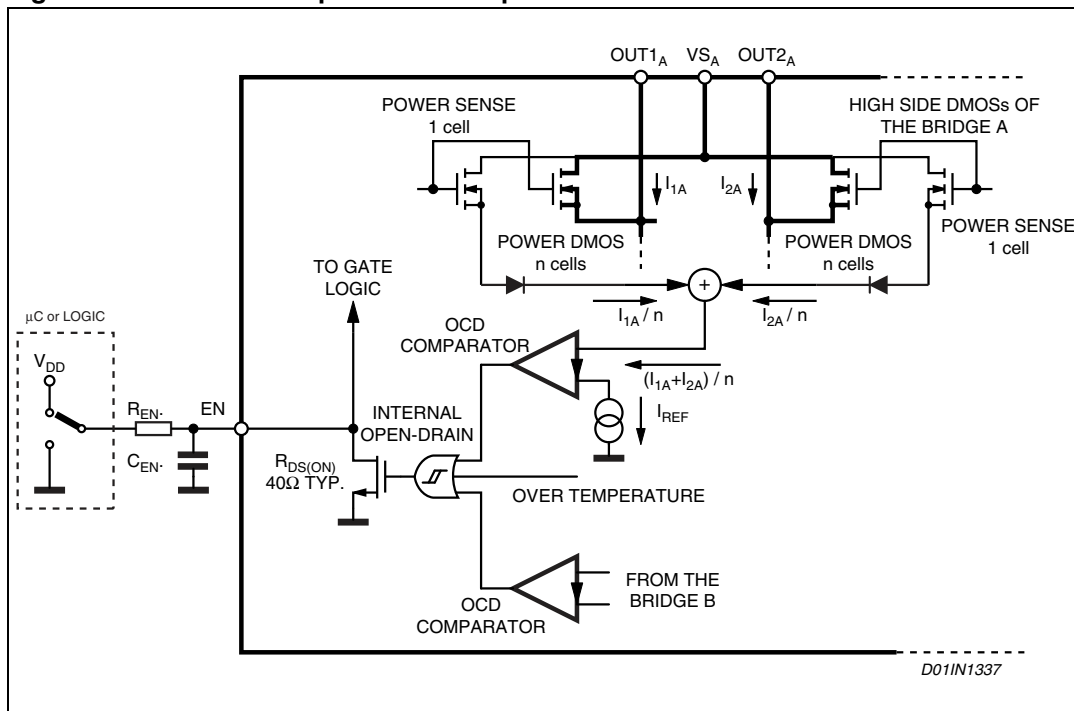

Figure 22 shows the overcurrent detection operation. The disable time $t_{DISABLE}$ before recovering normal operation can be easily programmed by means of the accurate thresholds of the logic inputs. It is affected both by C_{EN} and R_{EN} values and its magnitude is reported in Figure 23. The delay time t_{DELAY} before turning off the bridge when an overcurrent has been detected depends only by C_{EN} value. Its magnitude is reported in Figure 24.

C_{EN} is also used to provide immunity to pin EN against fast transient noises. Therefore the value of C_{EN} should be chosen as big as possible according to the maximum tolerable delay time and the R_{EN} value should be chosen according to the desired disable time.

The resistor R_{EN} should be chosen in the range from 2.2 kΩ to 180 kΩ. Recommended values for R_{EN} and C_{EN} are respectively 100 kΩ and 5.6 nF that allow 200 μs disable time to be obtained.

Figure 22. Overcurrent protection waveforms

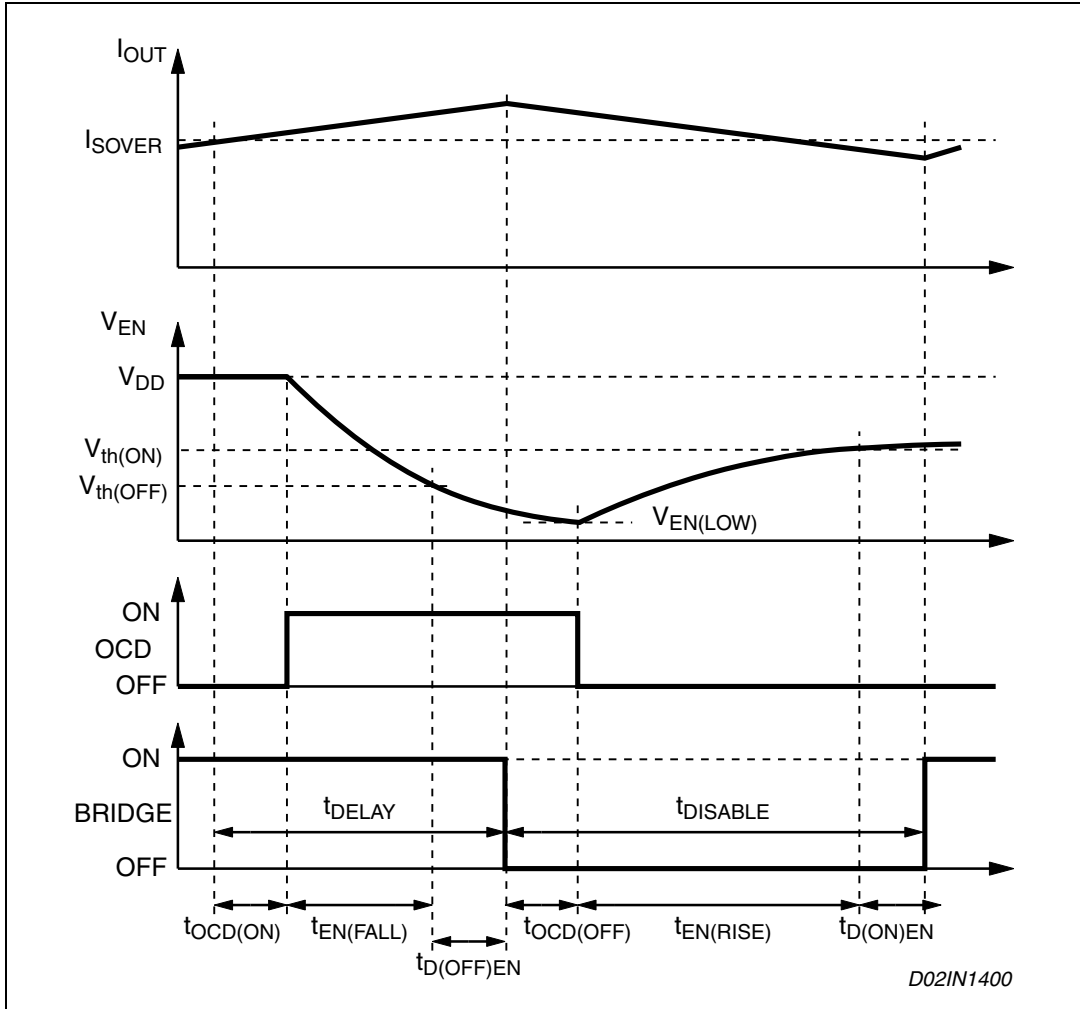

Figure 23. t_{DISABLE} versus C_{EN} and R_{EN} ($V_{\text{DD}} = 5 \text{ V}$)

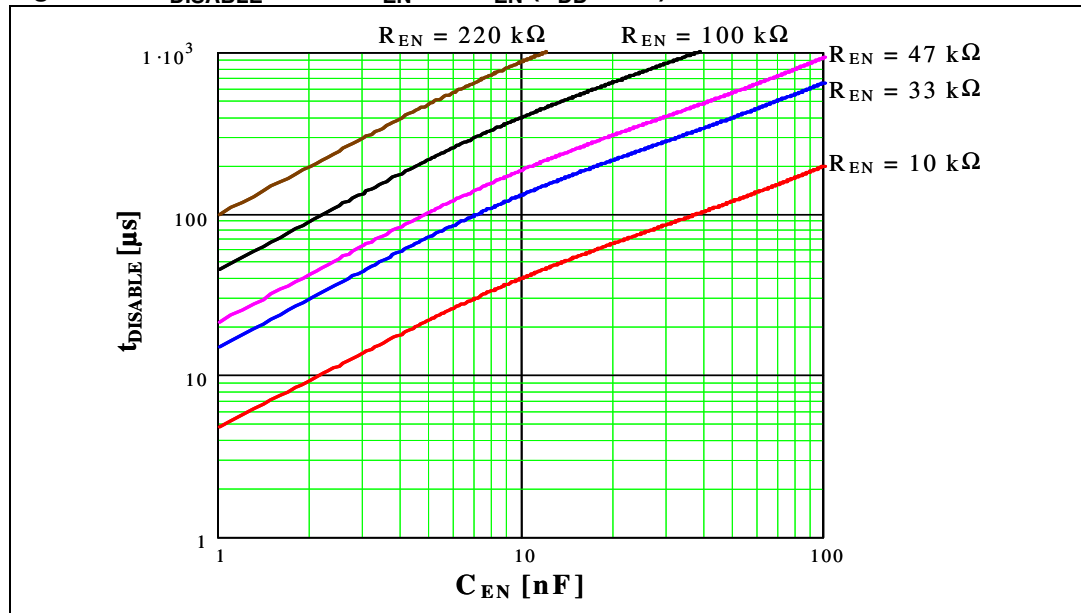
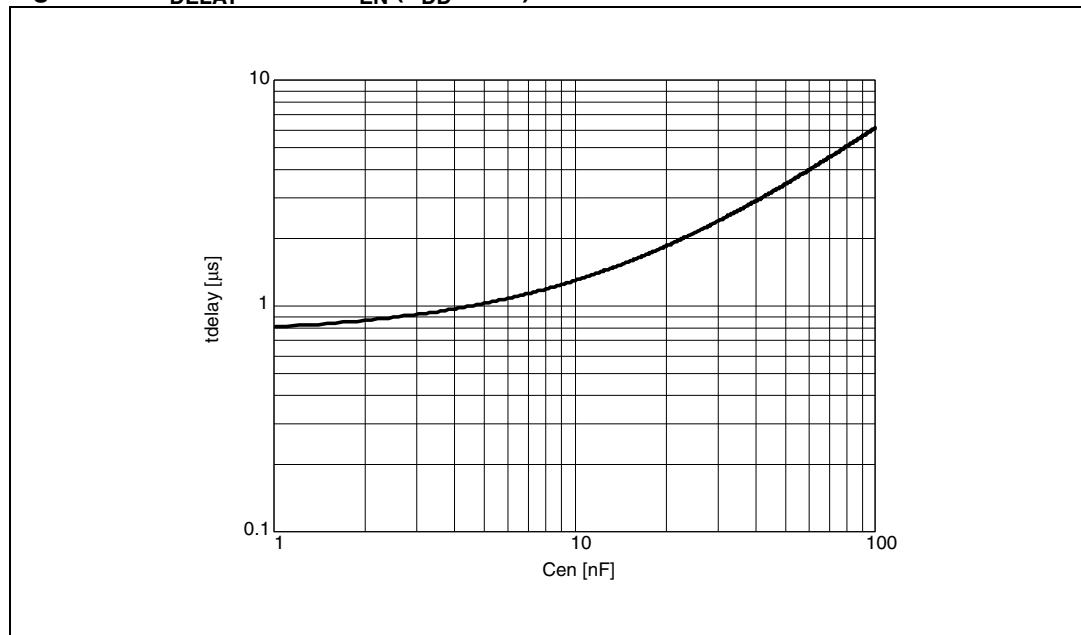

Figure 24. t_{DELAY} versus C_{EN} ($V_{\text{DD}} = 5 \text{ V}$)



4.7 Thermal protection

In addition to the overcurrent protection, the L6228Q integrates a thermal protection to prevent the device destruction in case of junction overtemperature. It senses the die temperature by means of a sensible element integrated in the die. The device switches off when the junction temperature reaches 165 °C (typ. value) with 15 °C hysteresis (typ. value).

5 Application information

A typical bipolar stepper motor driver application using L6228Q is shown in [Figure 25](#). Typical component values for the application are shown in [Table 7](#). A high quality ceramic capacitor in the range from 100 to 200 nF should be placed between the power pins (VS_A and VS_B) and ground near the L6228Q to improve the high frequency filtering on the power supply and to reduce high frequency transients generated by the switching. The capacitor connected from the EN input to ground sets the shut down time when an overcurrent is detected (see overcurrent protection). The two current sensing inputs ($SENSE_A$ and $SENSE_B$) should be connected to the sensing resistors with a trace length as short as possible in the layout. The sense resistors should be non-inductive resistors to minimize the di/dt transients across the resistor. To increase noise immunity, unused logic pins (except EN) are connected to 5 V (high logic level) or GND (low logic level) (see pin description). It is recommended power ground and signal ground to be separated on PCB.

Table 7. Component values for typical application

Component	Value
C_1	100 μ F
C_2	100 nF
C_A	1 nF
C_B	1 nF
C_{BOOT}	220 nF
C_P	10 nF
C_{EN}	5.6 nF
C_{REF}	68 nF
D_1	1N4148
D_2	1N4148
R_A	39 k Ω
R_B	39 k Ω
R_{EN}	100 k Ω
R_{SENSEA}	0.6 Ω
R_{SENSEB}	0.6 Ω

Figure 25. Typical application

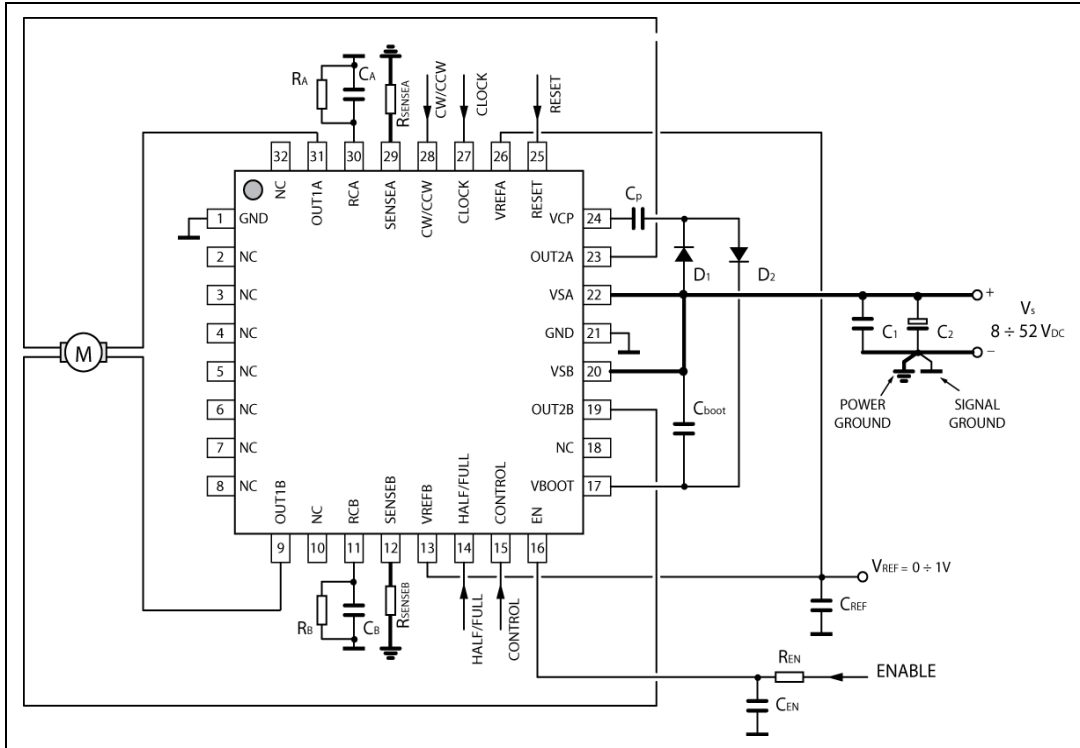

Note: To reduce the IC thermal resistance, so to improve the dissipation path, the NC pins can be connected to GND.

6 Output current capability and IC power dissipation

The approximate relation between the output current and the IC power dissipation using PWM current control driving a two-phase stepper motor, for different driving sequences (see [Figure 26](#), [Figure 27](#), [Figure 28](#) and [Figure 29](#)):

- HALF-STEP mode ([Figure 26](#)) in which alternately one phase/two phases are energized.
- NORMAL DRIVE (FULL-STEP TWO PHASE ON) mode ([Figure 27](#)) in which two phases are energized during each step.
- WAVE DRIVE (FULL-STEP ONE PHASE ON) mode ([Figure 27](#)) in which only one phase is energized at each step.
- MICROSTEPPING mode ([Figure 29](#)), in which the current follows a sine wave profile, provided through the V_{ref} pins.

For a given output current and driving sequence, the power dissipated by the IC can be easily evaluated, in order to establish which package should be used and how large the on-board copper dissipating area must be to guarantee a safe operating junction temperature (125 °C maximum).

Figure 26. IC power dissipation versus output current in HALF-STEP mode

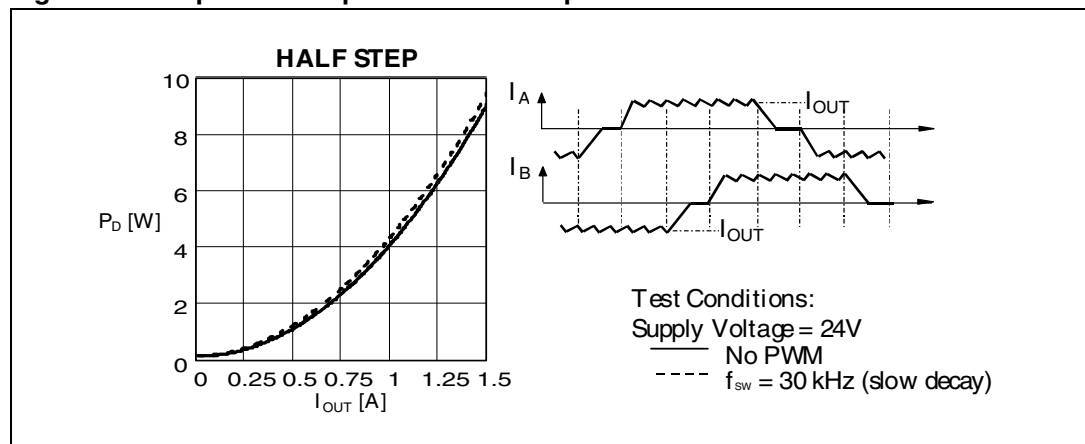

Figure 27. IC power dissipation versus output current in NORMAL mode (full-step-two-phase on)

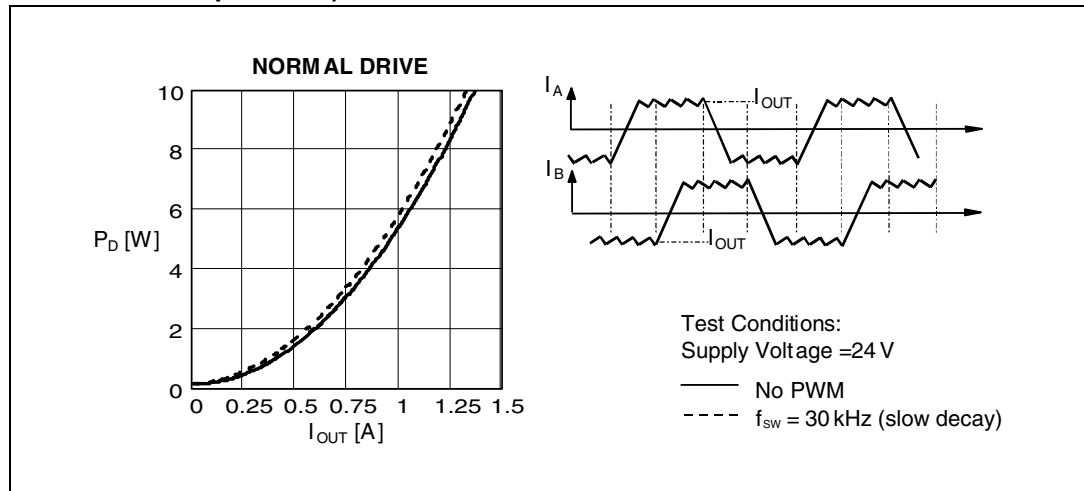

Figure 28. IC power dissipation versus output current in WAVE mode (full-step-one phase-on)

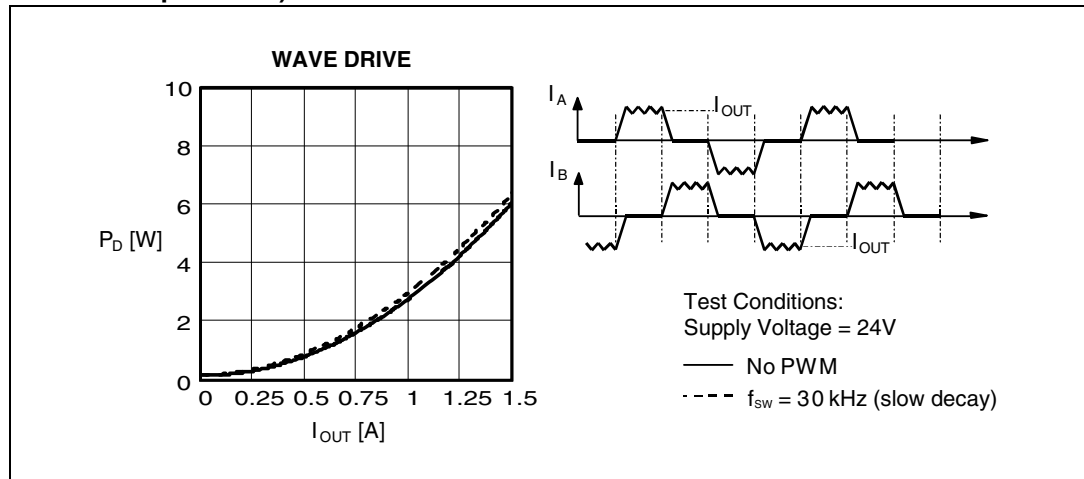
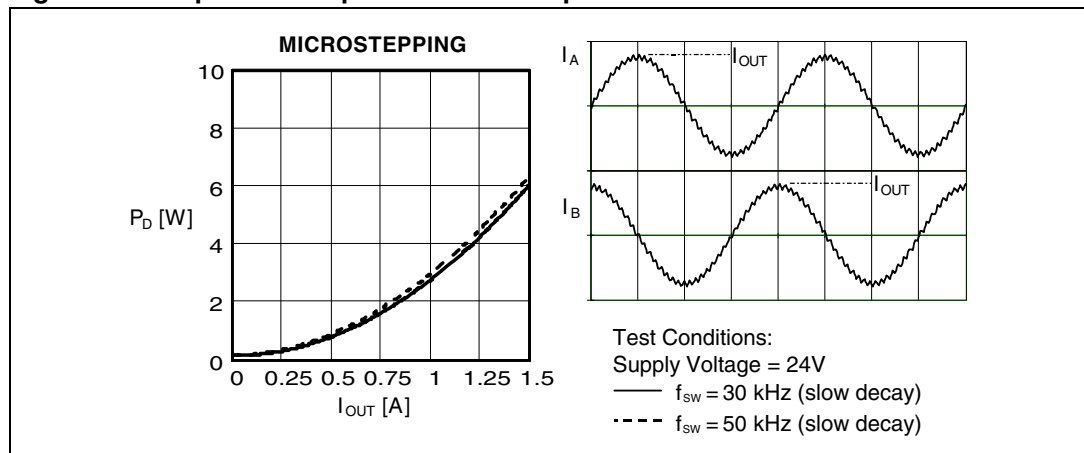

Figure 29. IC power dissipation versus output current in MICROSTEPPING mode



7 Thermal management

In most applications the power dissipation in the IC is the main factor that sets the maximum current that can be delivered by the device in a safe operating condition. Therefore, it has to be taken into account very carefully. Besides, the available space on the PCB, the right package should be chosen considering the power dissipation. Heat sinking can be achieved using copper on the PCB with proper area and thickness.

For instance, using a VFQFPN32L 5x5 package the typical $R_{th(JA)}$ is about 42 °C/W when mounted on a double-layer FR4 PCB with a dissipating copper surface of 0.5 cm² on the top side plus 6 cm² ground layer connected through 18 via holes (9 below the IC).

8 Package mechanical data

In order to meet environmental requirements, ST offers these devices in different grades of ECOPACK® packages, depending on their level of environmental compliance. ECOPACK® specifications, grade definitions and product status are available at: www.st.com. ECOPACK® is an ST trademark.

Table 8. VFQFPN32 5x5x1.0 pitch 0.50

Dim.	mm		
	Min.	Typ.	Max.
A	0.80	0.85	0.95
b	0.18	0.25	0.30
b1	0.165	0.175	0.185
D	4.85	5.00	5.15
D2	3.00	3.10	3.20
D3	1.10	1.20	1.30
E	4.85	5.00	5.15
E2	4.20	4.30	4.40
E3	0.60	0.70	0.80
e		0.50	
L	0.30	0.40	0.50
ddd			0.08

Note: VFQFPN stands for thermally enhanced very thin profile fine pitch quad flat package no lead. Very thin profile: $0.80 < A < 1.00$ mm.

Details of terminal 1 are optional but must be located on the top surface of the package by using either a mold or marked features.

Figure 30. Package dimensions

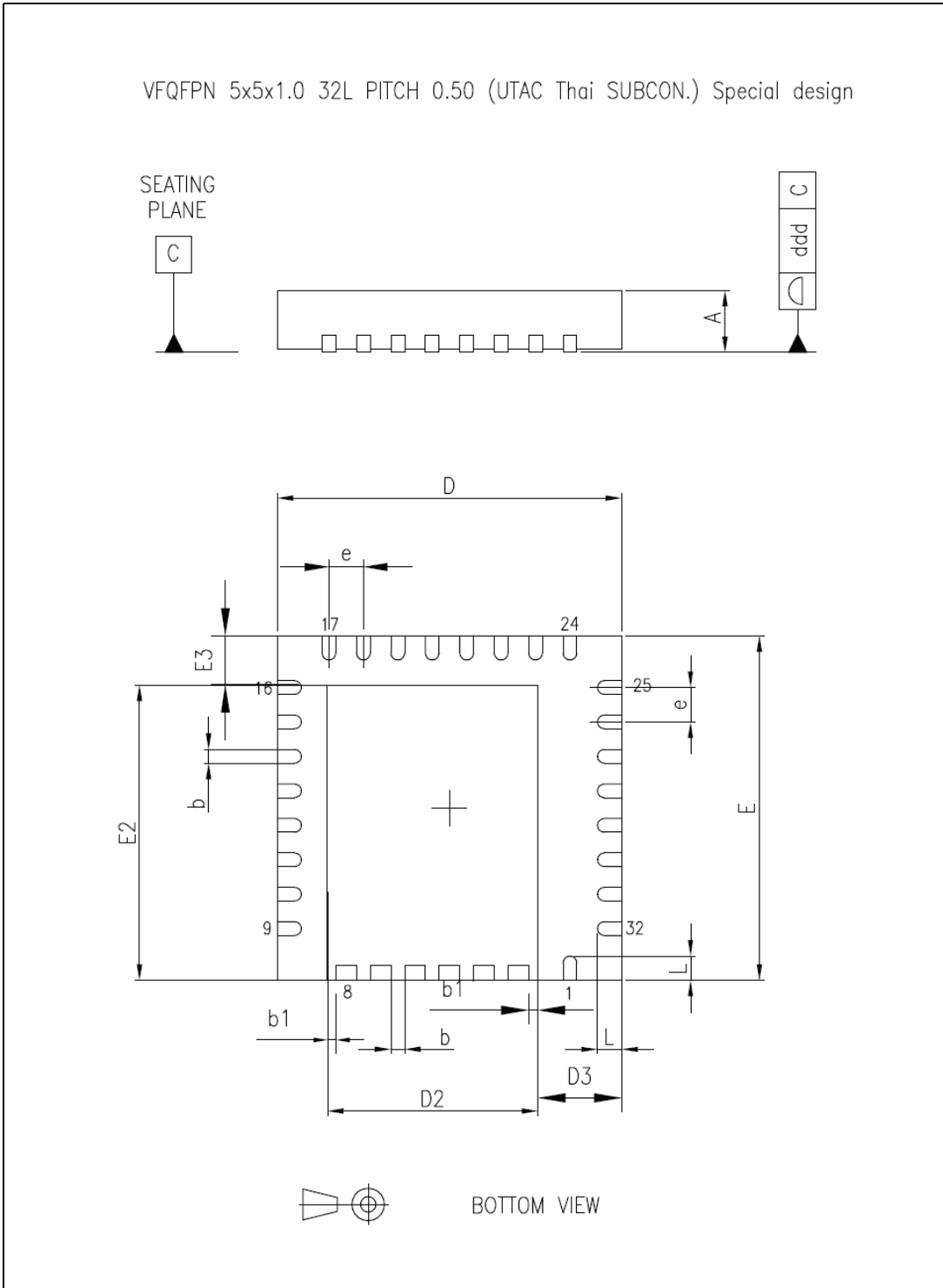

9 Ordering information

Table 9. Ordering information

Order code	Package	Packaging
L6228Q	VFQFPN32 5x5x1.0 mm	Tube
L6228QTR		Tape and reel

10 Revision history

Table 10. Document revision history

Date	Revision	Changes
14-Jan-2008	1	First release.
10-Jun-2008	2	Updated: <i>Figure 25 on page 24</i> Added: <i>Note 1 on page 4</i>
28-Jan-2009	3	Updated value in <i>Table 3: Thermal data on page 4</i>
31-Aug-2010	4	Updated <i>Table 9</i>
28-Jan-2013	5	Updated <i>Table 2</i> . Minor text changes.

Please Read Carefully:

Information in this document is provided solely in connection with ST products. STMicroelectronics NV and its subsidiaries ("ST") reserve the right to make changes, corrections, modifications or improvements, to this document, and the products and services described herein at any time, without notice.

All ST products are sold pursuant to ST's terms and conditions of sale.

Purchasers are solely responsible for the choice, selection and use of the ST products and services described herein, and ST assumes no liability whatsoever relating to the choice, selection or use of the ST products and services described herein.

No license, express or implied, by estoppel or otherwise, to any intellectual property rights is granted under this document. If any part of this document refers to any third party products or services it shall not be deemed a license grant by ST for the use of such third party products or services, or any intellectual property contained therein or considered as a warranty covering the use in any manner whatsoever of such third party products or services or any intellectual property contained therein.

UNLESS OTHERWISE SET FORTH IN ST'S TERMS AND CONDITIONS OF SALE ST DISCLAIMS ANY EXPRESS OR IMPLIED WARRANTY WITH RESPECT TO THE USE AND/OR SALE OF ST PRODUCTS INCLUDING WITHOUT LIMITATION IMPLIED WARRANTIES OF MERCHANTABILITY, FITNESS FOR A PARTICULAR PURPOSE (AND THEIR EQUIVALENTS UNDER THE LAWS OF ANY JURISDICTION), OR INFRINGEMENT OF ANY PATENT, COPYRIGHT OR OTHER INTELLECTUAL PROPERTY RIGHT.

UNLESS EXPRESSLY APPROVED IN WRITING BY TWO AUTHORIZED ST REPRESENTATIVES, ST PRODUCTS ARE NOT RECOMMENDED, AUTHORIZED OR WARRANTED FOR USE IN MILITARY, AIR CRAFT, SPACE, LIFE SAVING, OR LIFE SUSTAINING APPLICATIONS, NOR IN PRODUCTS OR SYSTEMS WHERE FAILURE OR MALFUNCTION MAY RESULT IN PERSONAL INJURY, DEATH, OR SEVERE PROPERTY OR ENVIRONMENTAL DAMAGE. ST PRODUCTS WHICH ARE NOT SPECIFIED AS "AUTOMOTIVE GRADE" MAY ONLY BE USED IN AUTOMOTIVE APPLICATIONS AT USER'S OWN RISK.

Resale of ST products with provisions different from the statements and/or technical features set forth in this document shall immediately void any warranty granted by ST for the ST product or service described herein and shall not create or extend in any manner whatsoever, any liability of ST.

ST and the ST logo are trademarks or registered trademarks of ST in various countries.

Information in this document supersedes and replaces all information previously supplied.

The ST logo is a registered trademark of STMicroelectronics. All other names are the property of their respective owners.

© 2013 STMicroelectronics - All rights reserved

STMicroelectronics group of companies

Australia - Belgium - Brazil - Canada - China - Czech Republic - Finland - France - Germany - Hong Kong - India - Israel - Italy - Japan - Malaysia - Malta - Morocco - Philippines - Singapore - Spain - Sweden - Switzerland - United Kingdom - United States of America

www.st.com