



CrossLink LIF-MD6000 Master Link Board - Revision C

Evaluation Board User Guide

FPGA-EB-02018 Version 1.0

June 2018

Contents

Acronyms in This Document	4
1. Introduction	5
2. Headers and Test Connections	7
3. Programming Circuit	8
3.1. Bridging Circuit	8
3.2. I ² C Expander	9
4. Power Supply	10
5. Status Indicators	12
6. SMA IO Link Board	13
7. Breakout IO Link Board	15
8. Ordering Information	18
References	19
Technical Support Assistance	19
Appendix A. LIF-MD6000-ML-EVN-BRD Schematics	20
Appendix B. LIF-MD6000-ML-EVN-BRD Bill of Materials	28
Appendix C. SMA-IOL-EVN-BRD Schematics	34
Appendix D. SMA-IOL-EVN-BRD Bill of Materials	35
Appendix E. B-IOL-EVN-BRD Schematics	36
Appendix F. B-IOL-EVN-BRD Bill of Materials	37
Revision History	38

Figures

Figure 1.1. Top View of Master Link Board and its Key Components.....	6
Figure 1.2. Bottom View of Master Link Board.....	6
Figure 3.1. Programming Block.....	8
Figure 3.2. Bridging Block	9
Figure 3.3. I ² C Expander Block	9
Figure 4.1. Power Supply Block.....	10
Figure 6.1. Top View of SMA IO Link Board	14
Figure 6.2. Bottom View of SMA IO Link Board	14
Figure 7.1. Top View of Breakout IO Link Board.....	17
Figure 7.2. Bottom View of Breakout IO Link Board.....	17

Tables

Table 2.1. Headers and Test Connectors	7
Table 4.1. Power LEDs	10
Table 4.2. Device Power Rail Summary and Test Points.....	11
Table 5.1. Status LED I/O Map	12
Table 6.1. Headers and Test Connectors	13
Table 6.2. U1 Connector Description.....	13
Table 7.1. Headers and Test Connectors	15
Table 7.2. U1 Connector Description.....	15
Table 7.3. J2 Header Description	16
Table 8.1. Ordering Information	18

Acronyms in This Document

A list of acronyms used in this document.

Acronym	Definition
CMOS	Complementary Metal-Oxide Semiconductor
CSI-2	Camera Serial Interface
DSI	Display Serial Interface
FTDI	Future Technology Devices International
I ² C	Inter-Integrated Circuit
IO	Input/Output
LVDS	Low-Voltage Differential Signaling
MIPI	Mobile Industry Processor Interface
SPI	Serial Peripheral Interface

1. Introduction

This document describes the Lattice Semiconductor CrossLink™ LIF-MD6000 Master Link Board –Revision C (Rev C) that supports a variety of demos, encompassing different signaling logic standards bridging with MIPI® CSI-2/DSI interface. The board's key component is the CrossLink Family device that features built in MIPI D-PHY hard blocks to support different bridging solutions.

For the latest information about this board, including optional Tx/Rx Link boards, demo files, further documentation and more, see the Lattice website at: www.latticesemi.com/masterlink.

For details about the CrossLink device, refer to [CrossLink Family Data Sheet \(FPGA-DS-02007\)](#).

The content of this user guide includes descriptions of on-board jumper settings, programming circuit, a complete set of schematics, and bill of materials for LIF-MD6000 Master Link Rev C board.

Refer to Appendix A, B, C, D, E, F for the schematic and BOM of the CrossLink LIF-MD6000 Master Link Rev C board and the schematics and BOMs of the Breakout IO Link and SMA IO Link boards that are included in the demo kit.

Circuits on the development kit board:

- Programming Circuit
 - Mini USB Type-B connector to FTDI
 - FTDI to CrossLink using SPI
 - FTDI to CrossLink using I²C
 - FTDI to XO3LF device using JTAG
- CrossLink
 - MIPI CSI-2/DSI hard block
 - Bridging of multiple signaling standards
 - SPI flash configuration
 - General Purpose Input/Output
 - LED display
- LCMXO3LF-1300E
 - I²C muxing

[Figure 1.1](#) shows the top view of the LIF-MD6000 Master Link Rev C board and its key components. [Figure 1.2](#) shows the bottom view of the board.

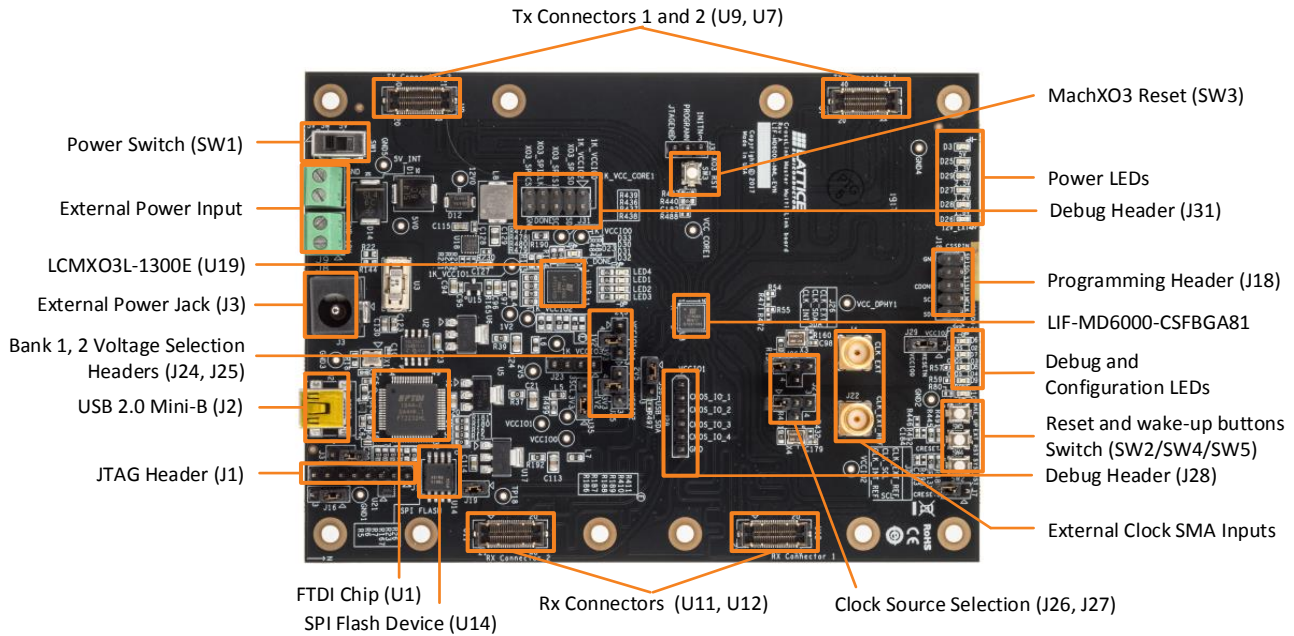

Figure 1.1. Top View of Master Link Rev C Board and its Key Components

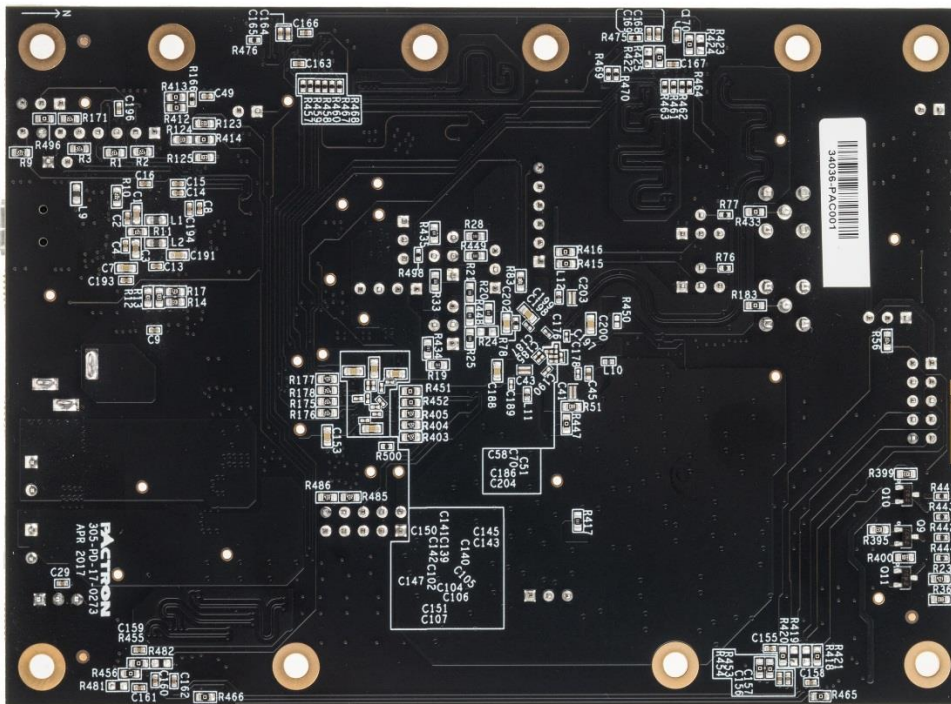

Figure 1.2. Bottom View of Master Link Rev C Board

2. Headers and Test Connections

Figure 1.1 shows the top view of the Master Link Rev C board. The headers and test connections on the board provide access to LIF-MD6000 Master Link Rev C board circuits. Table 2.1 lists the headers and test connectors.

Table 2.1. Headers and Test Connectors

Part	Description	Setting
J1	External JTAG interface - For LCMX03 only	—
J2	mini-B USB connector	—
J3	External 12V power jack	—
J4	External clock input for MIPI D-PHY reference clock	—
J7	SW2 selector	OPEN-NOP, SHORT-CONFIGURATION RESET
J8	External 12 V terminal block	Open
J9	External 5 V terminal block	Open
J16	SPI/I ² C programming selector for LIF-MD6000	1-2 (SPI), 2-3 (I ² C)
J18	External SP/I ² C access for LIF-MD6000	—
J19	SPI Flash chip select	OPEN-OFF, SHORT-ON
J22	External reference clock input for MIPI D-PHY reference clock	—
J23	LCMX03L debug header	—
J24	VCCIO1 Bank voltage selector	1-2 (2.5 V), 2-3 (3.3 V), 2-4 (1.2 V)
J25	VCCIO2 Bank voltage selector	1-2 (2.5 V), 2-3 (3.3 V), 2-4 (1.2 V)
J26	Internal/External clock and I ² C SDA Mux	1-2 (CLK_INT), 2-3 (CLK_EXT), 2-4 (SDA)
J27	Internal/External reference clock and I ² C SCL Mux	1-2 (CLK_INT_REF), 2-3 (CLK_EXT_REF), 2-4 (SCL)
J28	Reveal analyzer signal connector	—
J29	Reset signal voltage selector	1-2 (VCCIO2), 2-3 (VCCIO0)
J31	External SPI/I ² C access for LCMX03L	—
J32	LCMX03L configuration header	—
J35	SPI/I ² C programming selector for LIF-MD6000	1-2 (SPI), 2-3 (I ² C)
J36	SPI/I ² C programming selector for LIF-MD6000	1-2 (SPI), 2-3 (I ² C)
J37	FT2232H reset	OPEN-NORMAL OP, SHORT-RESET
SW1	External adaptor power ON/OFF	—
SW2	Configuration reset for LIF-MD6000	—
SW3	External reset for LCMX03L	—
SW4*	External reset for LIF-MD6000	—
SW5	PMU WAKEUP Switch for LIF-MD6000	—
U7	Tx Connectors for external interface	—
U9	Tx Connectors for external interface	—
U11	Rx Connectors for external interface	—
U12	Rx Connectors for external interface	—

***Note:** Some CrossLink demos utilize this reset signal to ball G9 of Bank 2 while it is configured as a 1.2 V Bank. However, LVCMOS12 inputs are no longer supported across all 3 Banks. Lattice Diamond® Software 3.9 and later will not allow this signal to be placed on a 1.2 V Bank. If it is necessary to recompile one of these demo projects, the necessary modifications should be made to the project and the board to move this reset signal to a non-1.2 V Bank on CrossLink.

3. Programming Circuit

The Mini-B USB connector is used for programming the board by using Lattice Diamond Programmer software. [Figure 3.1](#) shows the programming block of LIF-MD6000 Master Link Rev C board.

The Mini-B USB connector interfaces to the FTDI FT2232H IC. The FTDI IC works with Diamond Programmer software to provide interfaces for:

- JTAG – to program MachXO3 LCMXO3LF-1300E
- SPI – to program CrossLink and/or SPI Flash Memory
- I²C – to program CrossLink

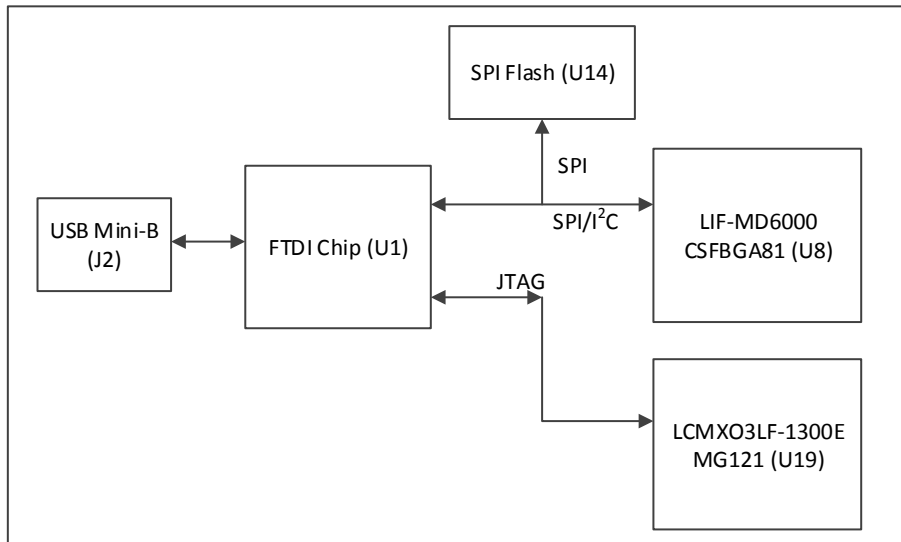

Figure 3.1. Programming Block

3.1. Bridging Circuit

[Figure 3.2](#) shows the block diagram of bridging of different standard interfaces. The CrossLink device is used as a bridging device that supports a variety of I/O standards. This demo board supports development of the following interface bridges:

- 1:1 MIPI DSI Display Interface Bridge
- 1:2 MIPI DSI Display Interface Bridge
- 2:1 MIPI CSI-2 Image Sensor Aggregator Bridge
- CMOS to MIPI CSI-2 Image Sensor Interface Bridge
- MIPI CSI-2 to CMOS Image Sensor Interface Bridge
- MIPI DSI to CMOS Display Interface Bridge
- OpenLDI LVDS to MIPI DSI Display Interface Bridge
- CMOS to MIPI DSI Display Interface Bridge

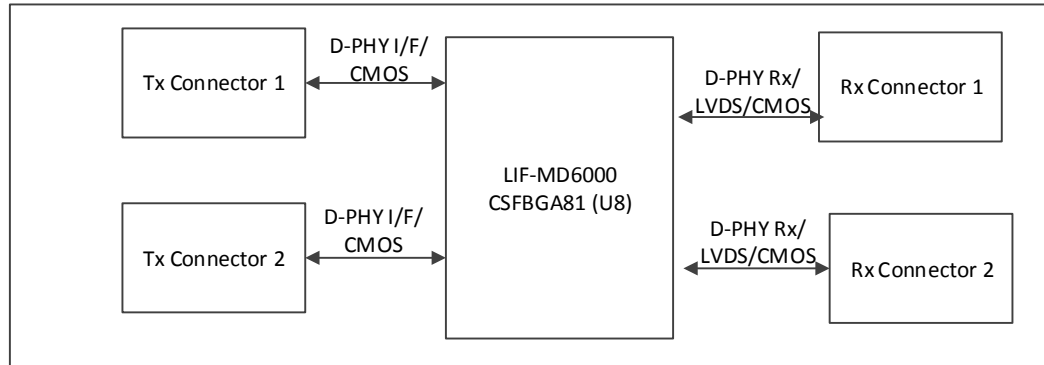

Figure 3.2. Bridging Block

3.2. I²C Expander

Figure 3.3 shows the block diagram of the I²C expander. The LCMXO3LF-1200E device is used as an I²C expander and it supports a single master and multiple slave devices connected to the board. The master I²C interface is connected to the Tx header and the slave device I²C interface is connected to the Rx connectors supporting any slave device access from the master based on the slave address.

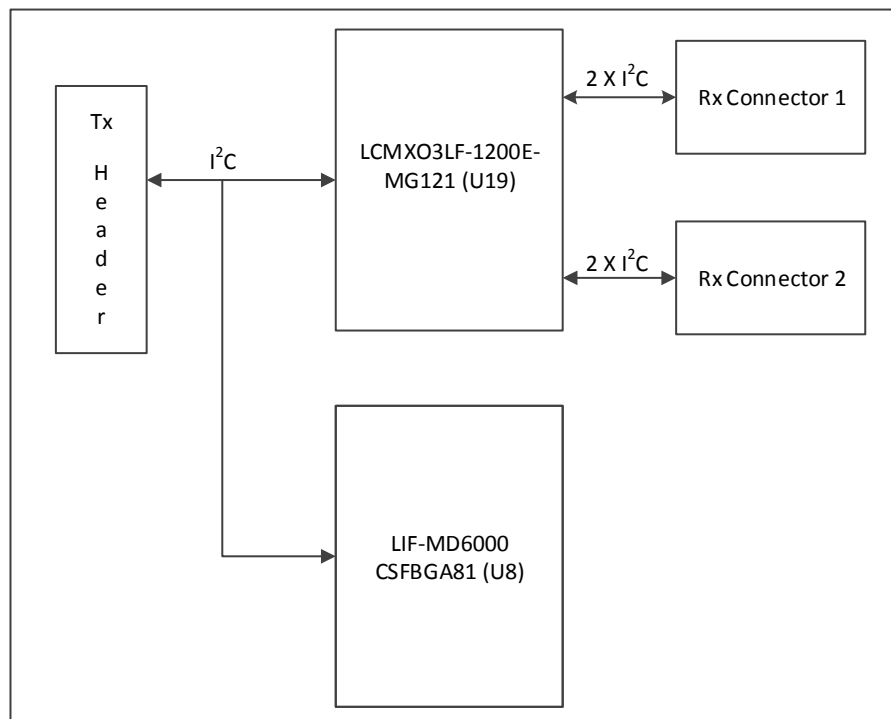

Figure 3.3. I²C Expander Block

4. Power Supply

The power supply to the development kit is provided by the Mini-B USB connector or from an external adaptor.

Figure 4.1 shows the power supply block of the CrossLink LIF-MD6000 Master Link Rev C board. The external adaptor provides 12 V power source through voltage regulators on the board to CrossLink and LCMXO3LF-1300E, as well as to the external boards connected to Tx and Rx Headers. The Mini-B USB connector provides 5 V to the various voltage regulators and is also used for device programming. Each I/O and core voltage rail on the board is accessible by a test point on the board. The current flowing to each rail can be measured using a 1 Ω resistor placed in the path of each voltage rail.

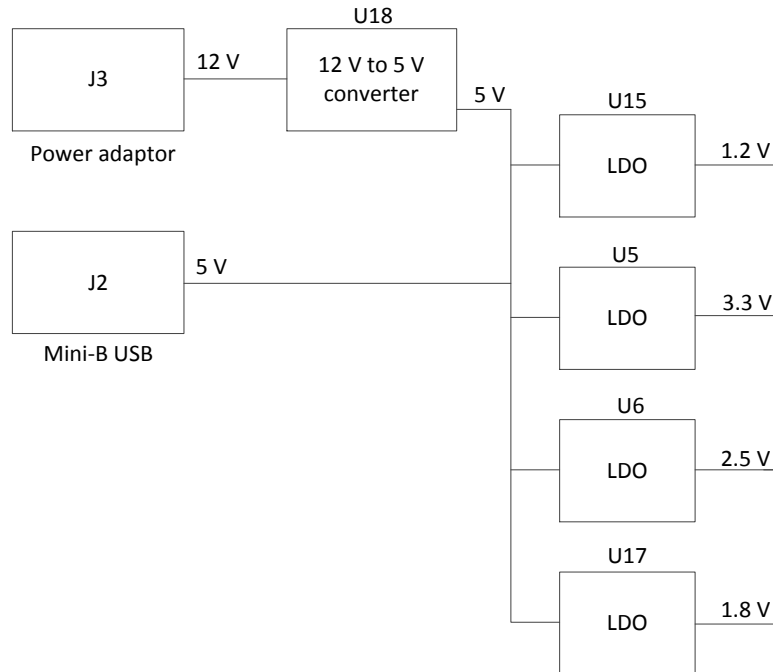

Figure 4.1. Power Supply Block

Table 4.1 lists the device power rails. There are five voltage regulators on the board used to supply the 5 V, 3.3 V, 2.5V 1.8 V, and 1.2 V rails. The input to these regulators is either from the Mini-B USB connector (J2), an external 12 V adaptor (J3), or an external power supply to the terminal blocks of J8 or J9. Switch SW1 is used to connect or disconnect power to the board.

Table 4.1. Power LEDs

Voltage Rail	LEDs	Color
12	D26	Green
5	D3	Green
3.3	D25	Green
2.5	D29	Green
1.8	D28	Green
1.2	D27	Green

Table 4.2 lists the board voltage rails, including the rail source voltage, test point number, and current sense resistor number.

Table 4.2. Device Power Rail Summary and Test Points

Voltage Rail	Source Rail	Current Sense Resistor	Test Points
12 V	—	—	12V0
5 V	12 V	—	5V0
+3.3 V	5 V	—	3V3
+2.5 V	5 V	—	2V5
+1.8 V	5 V	—	—
+1.2 V	5 V	—	1V2
VCC_CORE	+1.2 V	R19	VCC_CORE1
VCCIO0	+2.5 V / +3.3 V	R20 / R24	VCCIO0
VCCIO1	+1.2 V / +2.5 V / +3.3 V	R21 / R25 / R434 / R448	VCCIO1
VCCIO2	+1.2 V / +2.5 V / +3.3 V	R28 / R33 / R435 / R449	VCCIO2
VCC_DPHY	+1.2 V	R417	VCC_DPHY
1K_VCC_CORE	+1.2 V	R190	1K_VCC_CORE1
1K_VCCIO0	+2.5 V / +3.3 V	R410 / R411	1K_VCCIO0
1K_VCCIO1	+2.5 V / +3.3 V	R184 / R185	1K_VCCIO1
1K_VCCIO2	+2.5 V / +3.3 V	R186 / R187	1K_VCCIO2
1K_VCCIO3	+2.5 V / +3.3 V	R188 / R189	1K_VCCIO3

5. Status Indicators

The LED status indicators on the board show power, configuration, and application status. [Table 5.1](#) lists the status LED I/O map.

Table 5.1. Status LED I/O Map

Device	LED	Net Name	Color
CrossLink	D6	CMOS_IO_1	Blue
CrossLink	D7	CMOS_IO_2	Blue
CrossLink	D8	CMOS_IO_3	Blue
CrossLink	D9	CMOS_IO_4	Blue
CrossLink	D10	CDONE	Green
LCMX03LF-1300E	D23	DONE	Red
LCMX03LF-1300E	D30	LED1	Blue
LCMX03LF-1300E	D31	LED2	Blue
LCMX03LF-1300E	D32	LED3	Blue
LCMX03LF-1300E	D33	LED4	Blue

6. SMA IO Link Board

The SMA IO Link board connects to the CrossLink LIF-MD6000 Master Link Rev C board's Tx or Rx connectors (U7, U9, U11 or U12) and transfers signals to the respective SMA connectors.

Table 6.1. Headers and Test Connectors

Part	Description	Mapping to U1
J1	SMA connector for DCK_TX_P	Pin 1
J2	SMA connector for DCK_TX_N	Pin 2
J3	SMA connector for DATA0_TX_P	Pin 4
J4	SMA connector for DATA0_TX_N	Pin 5
J5	SMA connector for DATA1_TX_P	Pin 7
J6	SMA connector for DATA1_TX_N	Pin 8
J7	SMA connector for DATA2_TX_P	Pin 13
J8	SMA connector for DATA2_TX_N	Pin 14
J9	SMA connector for DATA3_TX_P	Pin 16
J10	SMA connector for DATA3_TX_N	Pin 17
J11	SMA connector for DATA4_TX_P	Pin 24
J12	SMA connector for DATA4_TX_N	Pin 25
J13	SMA connector for DATA5_TX_P	Pin 27
J14	SMA connector for DATA5_TX_N	Pin 28
U1	Connector to interface to CrossLink Master Link Rev C board	N/A

Table 6.2. U1 Connector Description

Pin	Name
1	CH4_DCK_P
2	CH4_DCK_N
3	GND
4	CH4_DATA0_P
5	CH4_DATA0_N
6	GND
7	CH4_DATA1_P
8	CH4_DATA1_N
9	GND
10	SN
11	SCLK
12	GND
13	CH4_DATA2_P
14	CH4_DATA2_N
15	GND
16	CH4_DATA3_P
17	CH4_DATA3_N
18	GND
19	12V
20	12V

Pin	Name
21	TBD
22	RESETN
23	PWR_5-0V
24	GND
25	GND
26	PWR_3-3V
27	GND
28	GND
29	PWR_1-8V
30	MOSI
31	MISO
32	PWR_1-8V
33	GND
34	GND
35	PWR_3-3V
36	GND
37	GND
38	PWR_5-0V
39	SDA
40	SCL

Note: U1 connector pin names may be different than the actual signal depending on which CrossLink LIF-MD6000 Master Link Rev C board connector this daughter board is connected to.

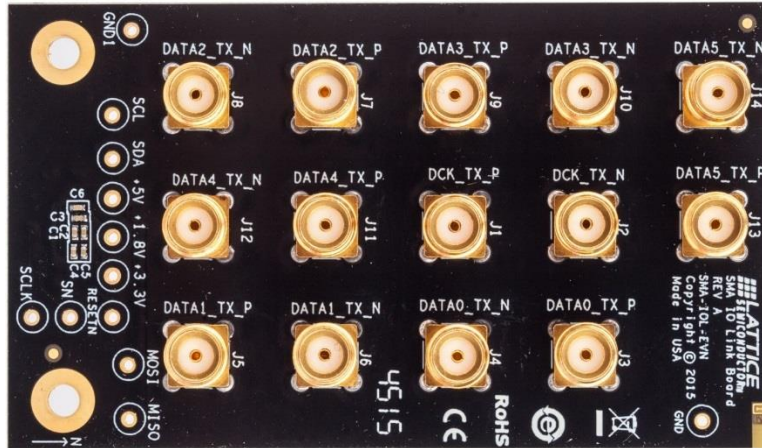

Figure 6.1. Top View of SMA IO Link Board

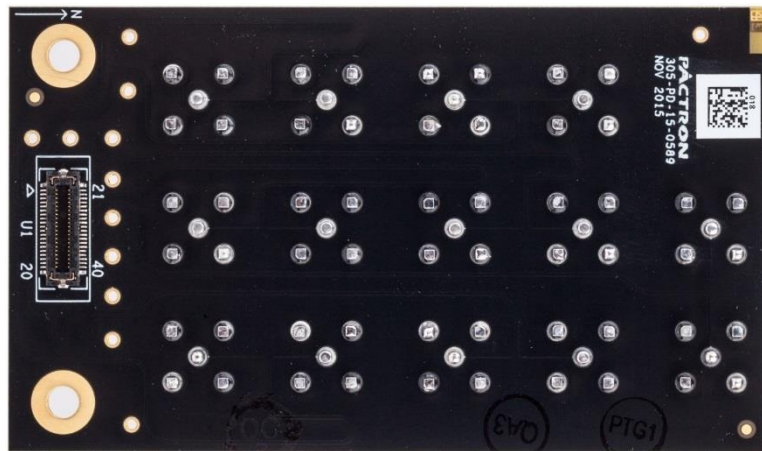

Figure 6.2. Bottom View of SMA IO Link Board

7. Breakout IO Link Board

The Breakout IO Link board connects to the CrossLink LIF-MD6000 Master Link Rev C board's Tx or Rx connectors (U7, U9, U11 or U12) and transfers signals to the 26-pin header (J2).

Table 7.1. Headers and Test Connectors

Part	Description	Setting
J2	13x2 Header	—
U1	Connector to interface to CrossLink Master Link Rev C board	—

Table 7.2. U1 Connector Description

Pin	Name
1	CH4_DCK_P
2	CH4_DCK_N
3	GND
4	CH4_DATA0_P
5	CH4_DATA0_N
6	GND
7	CH4_DATA1_P
8	CH4_DATA1_N
9	GND
10	SN
11	SCLK
12	GND
13	CH4_DATA2_P
14	CH4_DATA2_N
15	GND
16	CH4_DATA3_P
17	CH4_DATA3_N
18	GND
19	12V
20	12V

Pin	Name
21	TBD
22	RESETN
23	PWR_5-0V
24	GND
25	GND
26	PWR_3-3V
27	GND
28	GND
29	PWR_1-8V
30	MOSI
31	MISO
32	PWR_1-8V
33	GND
34	GND
35	PWR_3-3V
36	GND
37	GND
38	PWR_5-0V
39	SDA
40	SCL

Note: U1 connector pin names may be different than the actual signal depending on which CrossLink LIF-MD6000 Master Link Rev C board connector this daughter board is connected to.

Table 7.3. J2 Header Description

Pin	Name	Mapping to U1
1	+3.3V	N/A
2	+1.8V	N/A
3	RESETN	Pin 22
4	CH4_DCK_TX_P	Pin 1
5	SDA	Pin 39
6	CH4_DCK_TX_N	Pin 2
7	SCL	Pin 40
8	GND	N/A
9	GND	N/A
10	CH4_DATA0_TX_P	Pin 4
11	CH4_DATA3_TX_P	Pin 16
12	CH4_DATA0_TX_N	Pin 5
13	CH4_DATA3_TX_N	Pin 17
14	GND	N/A
15	GND	N/A
16	CH4_DATA1_TX_P	Pin 7
17	CH4_DATA4_TX_P	Pin 24
18	CH4_DATA1_TX_N	Pin 8
19	CH4_DATA4_TX_N	Pin 25
20	GND	N/A
21	GND	N/A
22	CH4_DATA2_TX_P	Pin 13
23	CH4_DATA5_TX_P	Pin 27
24	CH4_DATA2_TX_N	Pin 14
25	CH4_DATA5_TX_N	Pin 28
26	GND	N/A

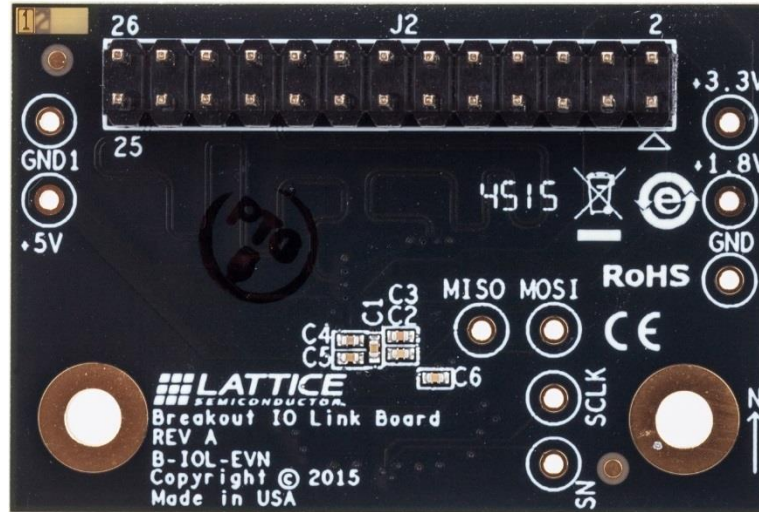

Figure 7.1. Top View of Breakout IO Link Board

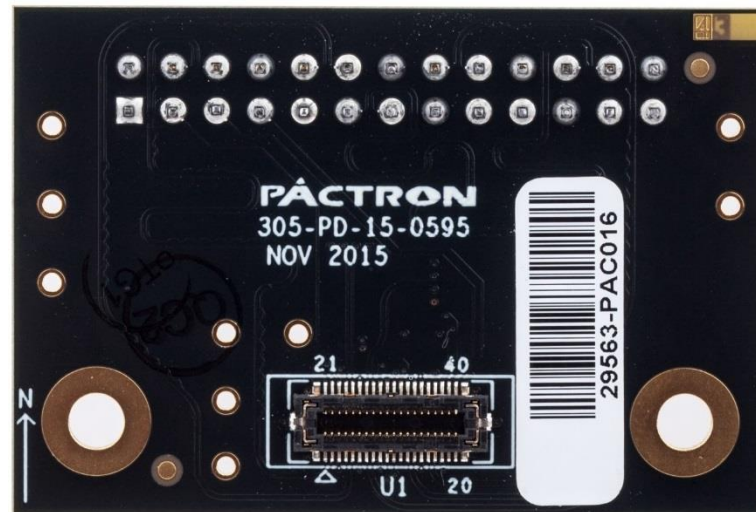



Figure 7.2. Bottom View of Breakout IO Link Board

8. Ordering Information

Table 8.1. Ordering Information

Description	Ordering Part Number	China RoHS Environment-Friendly Use Period (EFUP)
CrossLink: LIF-MD6000 Master Link Rev C Board (Includes 1 SMA IO Link Board and 1 Breakout IO Link Board)	LIF-MD6000-ML-EVN	
CrossLink: LIF-MD6000 IO Link Boards (Includes 1 SMA IO Link Board and 1 Breakout IO Link Board)	LIFMD-IOL-EVN	

References

For more information, refer to [CrossLink Family Data Sheet FPGA-DS-02007 \(previously DS1055\)](#).

Technical Support Assistance

Submit a technical support case through www.latticesemi.com/techsupport.

Appendix A. LIF-MD6000-ML-EVN-BRD Schematics

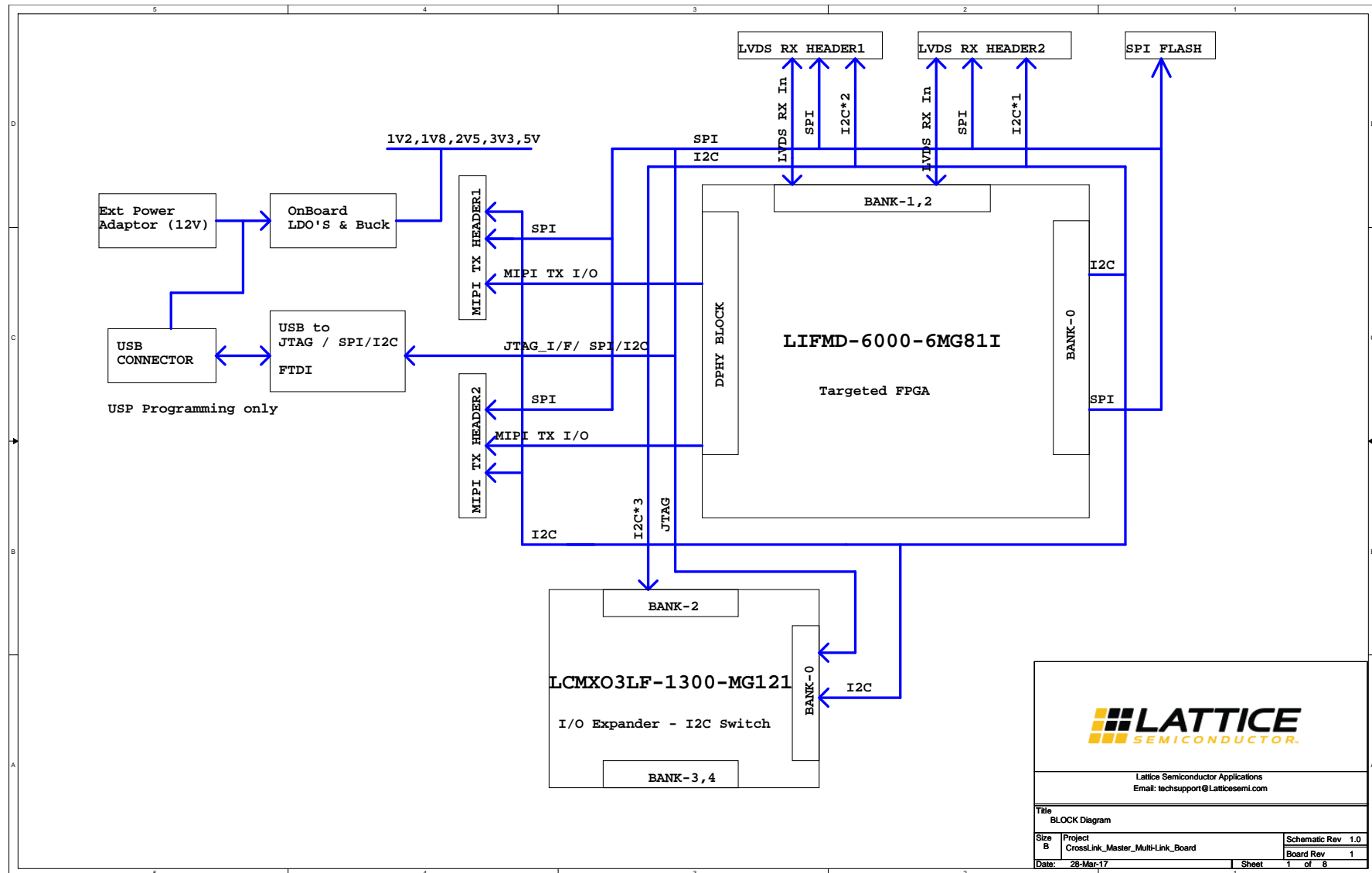

LIF-MD6000 Master Link Rev C Board Block Diagram

Lattice Semiconductor Applications
Email: techsupport@latticesemi.com

Title BLOCK Diagram		
Size B	Project CrossLink_Master_Multi-Link_Board	Schematic Rev 1.0
Date: 28-Mar-17	Sheet 1	Board Rev 1
		1 of 8

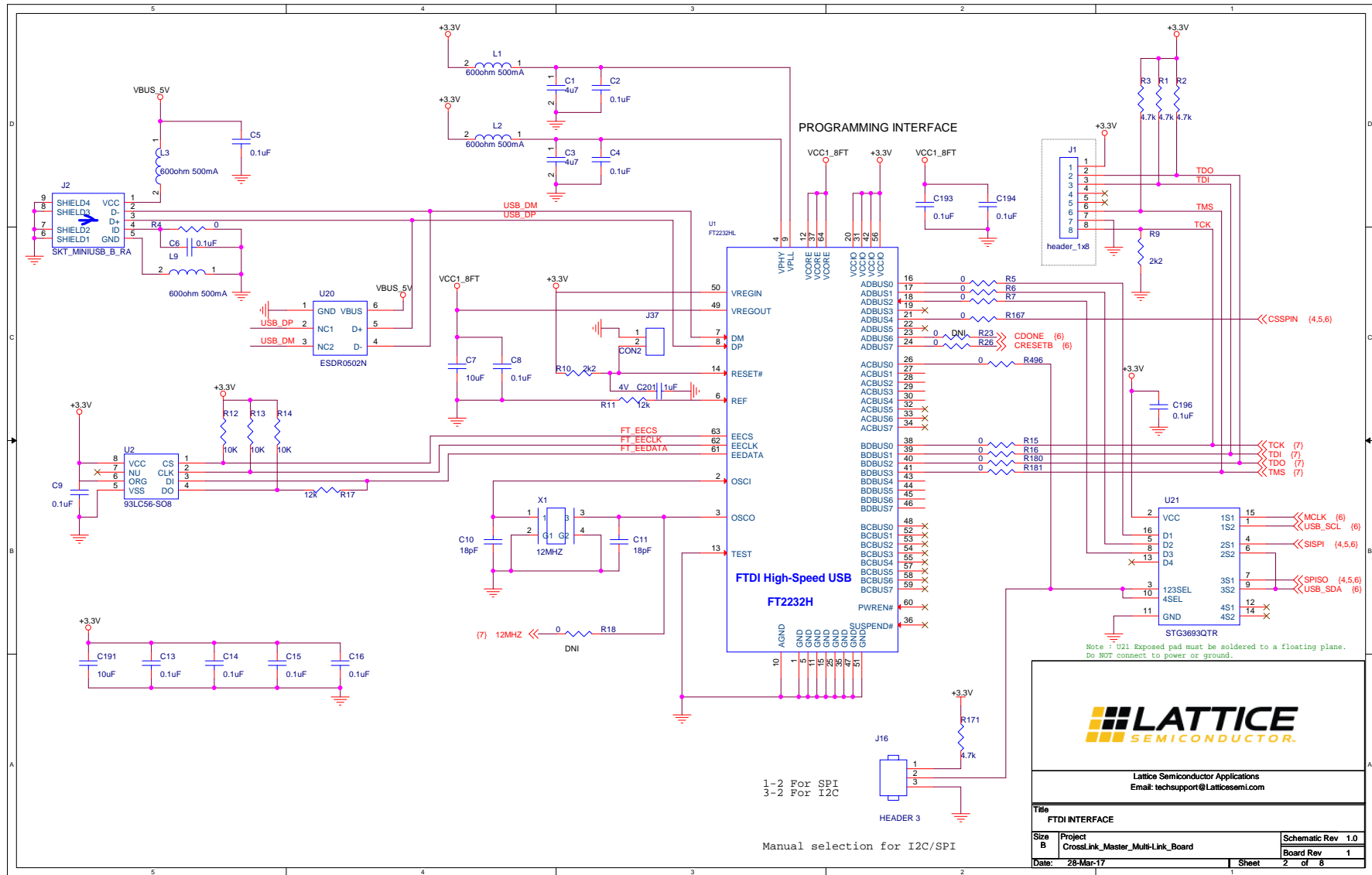

FTDI Interface

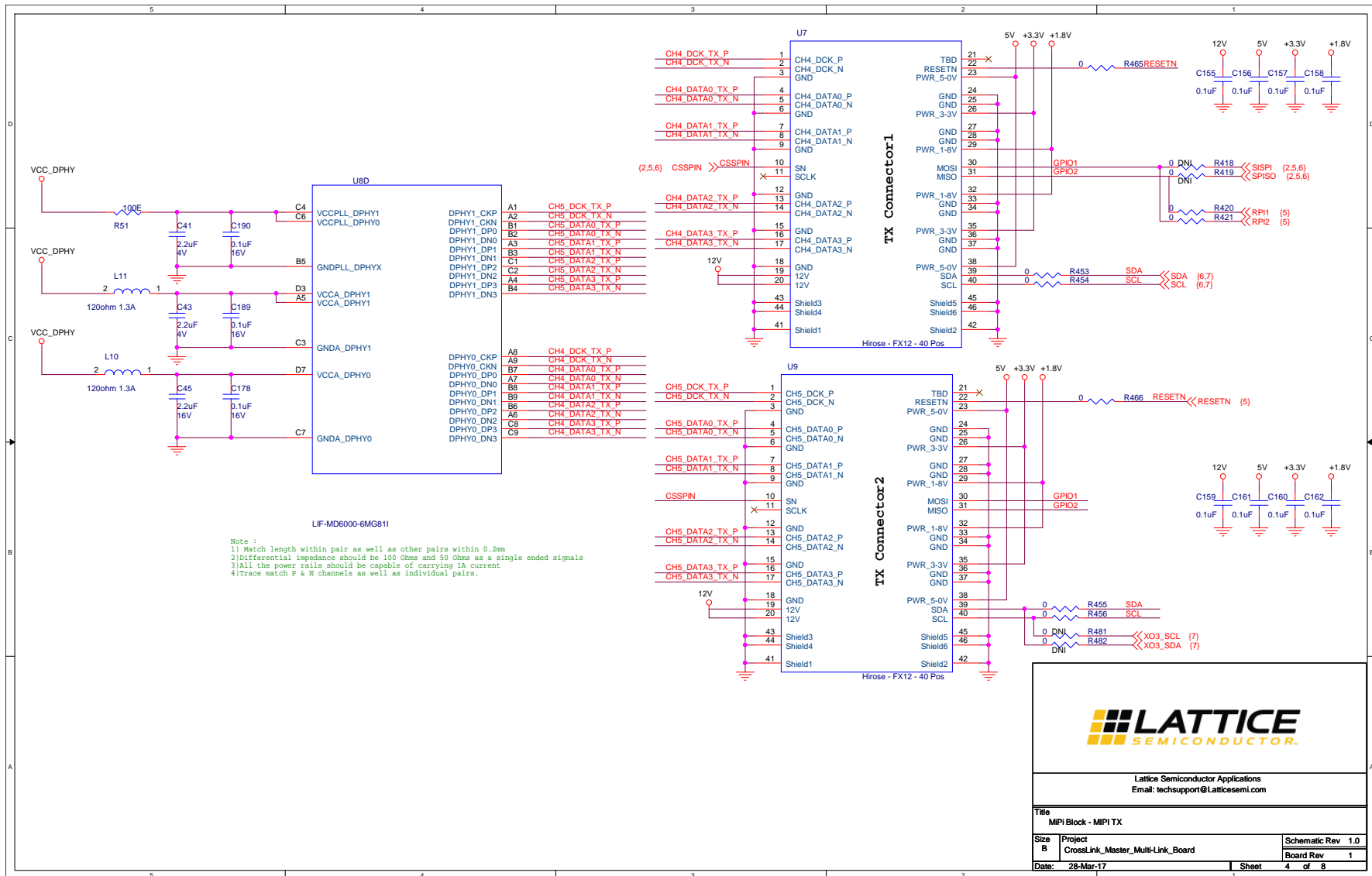

MIPI Block – MIPI TX

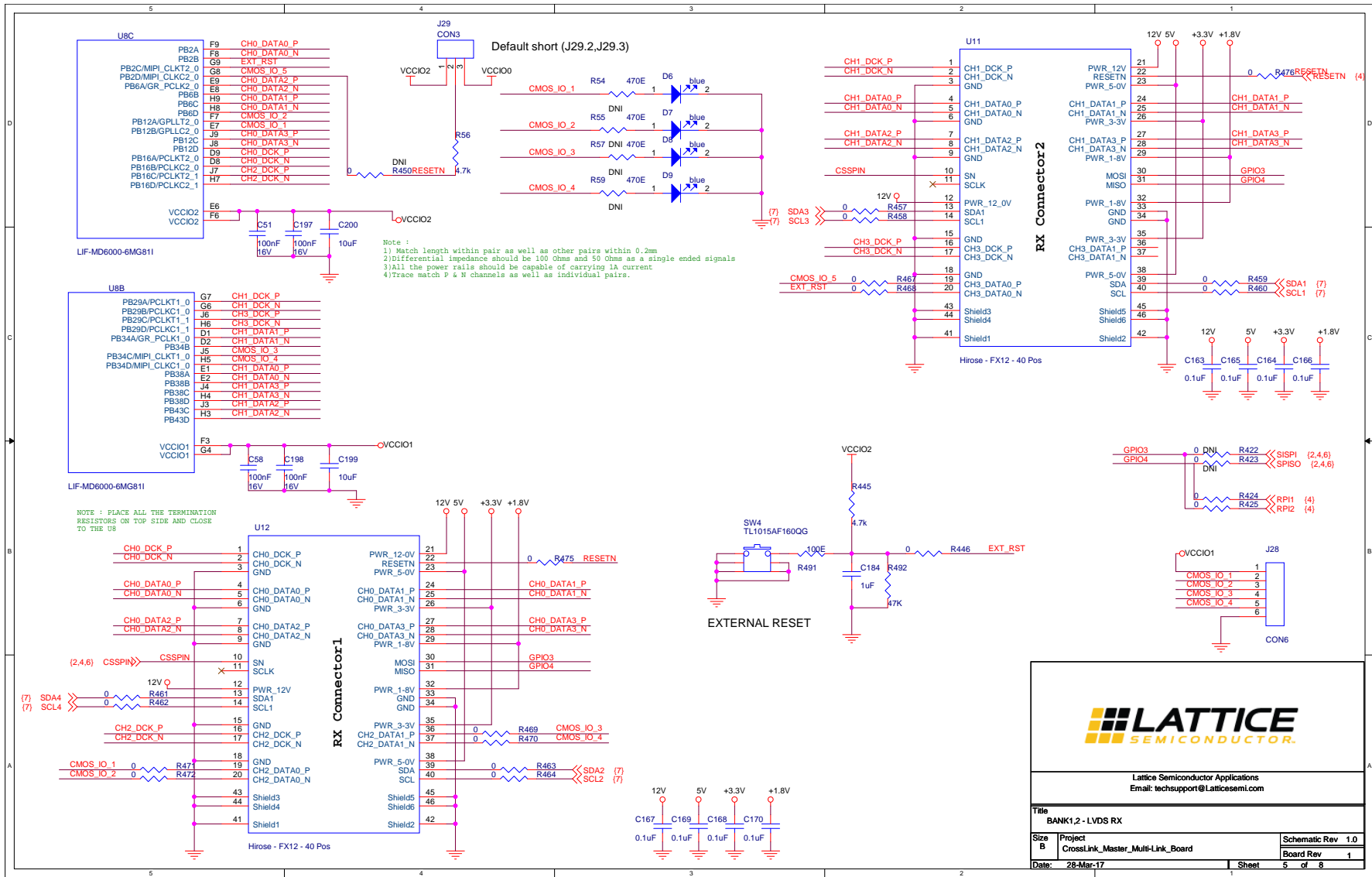

Bank 1, 2 – LVDS Rx

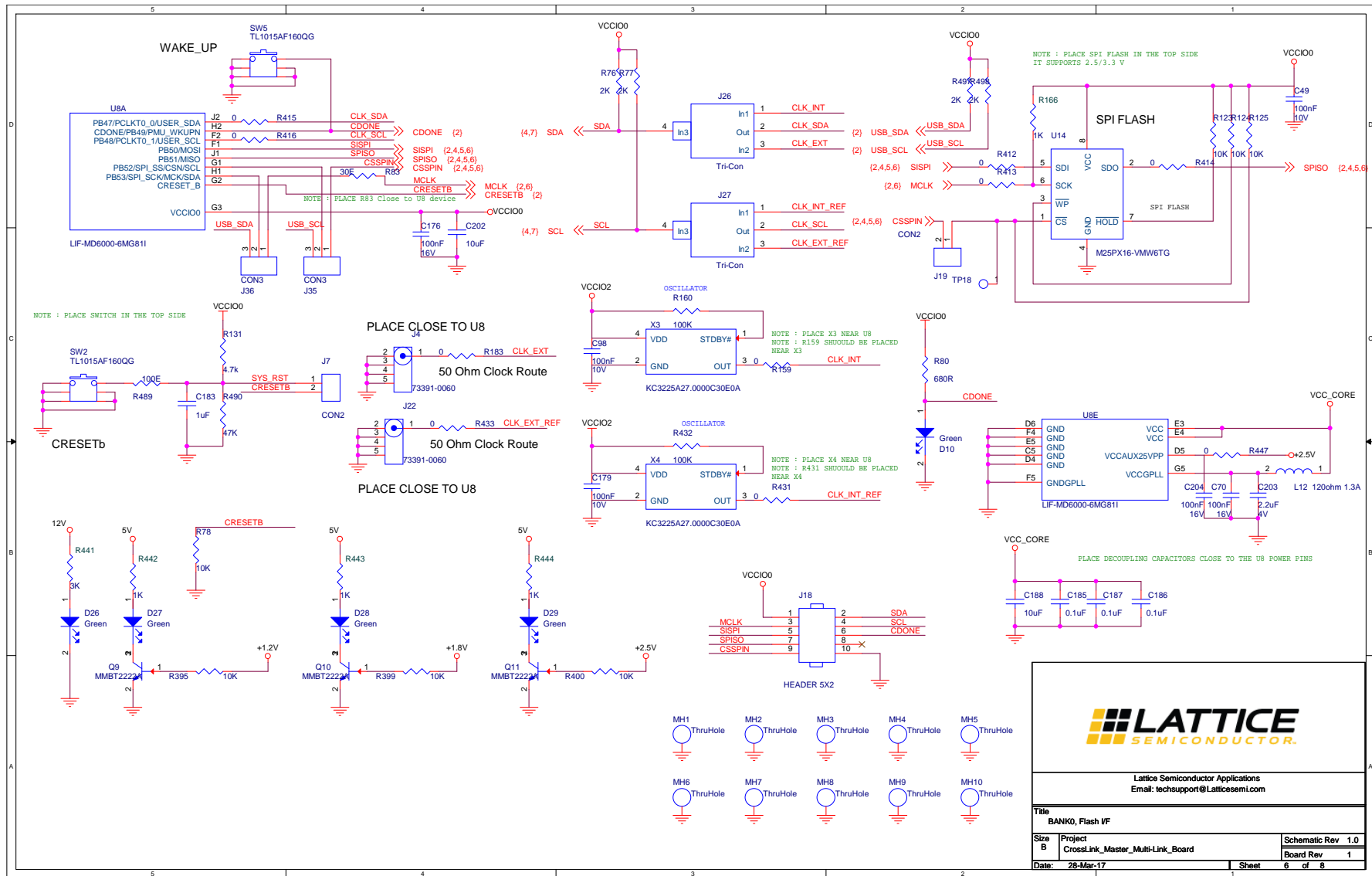

Bank0, Flash Interface

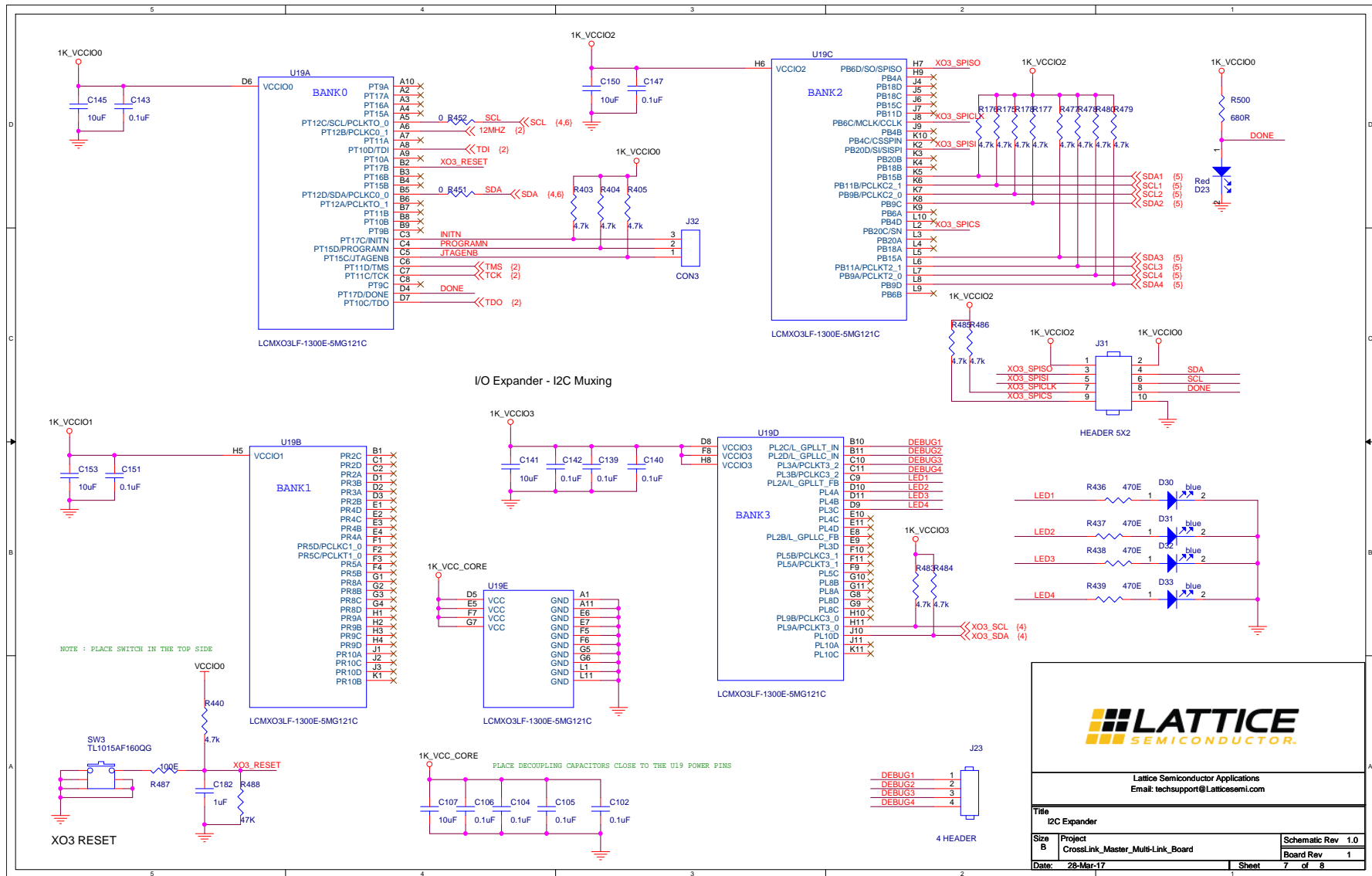

I²C Expander

Routing guidelines for MIPI & LVDS

- 1) All differential routes are required to have the same length between the positive (true) and the negative (complimentary) routes. Spacing between the positive (true) and the negative (complimentary) shall be 2 times trace width.
- 2) Target differential impedance shall be 100 Ohms
- 3) Trace length matching to be within 1.0 mm (40 mil) across the entire bus.
- 4) Use small humps for skew corrections
- 5) Place signal vias close together and remove copper in between vias. Traces to be fully shielded with GND stitching terminating at both trace end points
- 6) Board trace impedance results must be within ± 10 percent of target and Power plane impedance to be within ± 10 percent of target at operating frequency

MIPI & LVDS Simulation Requirement

- 1) MIPI Differential Mode insertion Loss shall be > -1.6 dB at 750 MHz
- 2) MIPI Differential Mode Return Loss shall be < -15 dB at 750 MHz
- 3) MIPI Common Mode Return Loss shall be < -15 dB at 750 MHz
- 4) LVDS differential mode return loss shall be < -16.5 dB at 600 MHz
- 5) LVDS common mode return loss shall be < -16.5 dB at 600 MHz
- 6) LVDS insertion loss shall be > -1.7 dB at 600 MHz
- 7) LVDS Cross coupling shall be < -22 dB for victim IO at 600 MHz
- 8) Power plane impedance to be within ± 10 percent of target at operating frequency



Lattice Semiconductor Applications
Email: techsupport@latticesemi.com

Title Layout Guidelines		
Size B	Project CrossLink_Master_Multi-Link_Board	Schematic Rev 1.0
Date 28-Mar-17	Sheet 8	Board Rev 1
		8 of 8

Layout Guidelines

Appendix B. LIF-MD6000-ML-EVN-BRD Bill of Materials

Item	Reference	Qty	Part	PCB Footprint	Comments	PART_NUMBER	Manufacturer	Description
1	C1,C3	2	4u7	C0603	—	ECJ-1VB0J475K	Panasonic	Cap Cer 4.7 μ F 6.3 V 10% X5R 0603
2	C2,C4,C5,C6,C8,C9,C13,C14,C15,C16,C29,C95,C97,C155,C156,C157,C158,C159,C160,C161,C162,C163,C164,C165,C166,C167,C168,C169,C170,C193,C194,C196	32	0.1 μ F	C0402	—	GRM155R61H104KE14D	Murata	CAP CER 0.1 μ F 50V X5R 0402
3	C7,C20,C23,C94,C96,C107,C114,C141,C145,C150,C153,C188,C191,C199,C200,C202	16	10 μ F	C0603	—	GRM188R61A106KE69D	Murata	CAP CER 10 μ F 10 V X5R 0603
4	C10,C11	2	18 pF	C0402	—	C0402C180K3GACTU	Kemet	CAP CER 18 pF 25 V NPO 0402
5	C21,C24,C113	3	22 μ F	C0805	—	LMK212BJ226MG-T	Taiyo Yuden	CAP CER 22 μ F 10 V X5R 0805
6	C41,C43,C203	3	2.2 μ F	C0306	—	LLL185C70G225ME01L	Murata	CAP CER 2.2 μ F 4 V X7S 0306
7	C45	1	2.2 μ F	C0402	—	GRM155R61C225KE44D	Murata	CAP CER 2.2 μ F 16 V X5R 0402
8	C49,C98,C179	3	100 nF	C0402	—	GRM155R61A104KA01D	Murata	CAP CER 0.1 μ F 10 V X5R 0402
9	C51,C58,C70,C176,C197,C198,C204	7	100 nF	C0201	—	C0603X5R1C104K030BC	TDK	CAP CER 0.1 μ F 16 V X5R 0201
10	C102,C104,C105,C106,C139,C140,C142,C143,C147,C151,C185,C186,C187,C178,C189,C190	16	0.1 μ F	C0201	—	GRM033R61C104ME84D	Murata	CAP CER 0.1 μ F 16 V X5R 0201
11	C115,C130	2	10 μ F	C0603	—	CL10A106MA8NRNC	Samsung	CAP CER 10 μ F 25 V 20% X5R 0603
12	C123	1	0.1 μ F	C0603	—	GRM188R71E104KA01D	Murata	CAP CER 0.1 μ F 25 V 10% X7R 0603
13	C127	1	680 pF	C0603	—	C0603C681J3GACTU	Kemet	CAP CER 680 pF 25 V 5% NPO 0603

Item	Reference	Qty	Part	PCB Footprint	Comments	PART_NUMBER	Manufacturer	Description
14	C128	1	0.47 μ F	C0402	—	CL05A474KA5NNNC	Samsung	CAP CER 0.47 μ F 25 V 10% X5R 0402
15	C129	1	47 μ F	C0805	—	C2012X5R1A476M125A C	TDK	CAP CER 47 μ F 10 V 20% X5R 0805
16	C182,C183,C184	3	1 μ F	C0402	—	C0402C105K9PACTU	Kemet	CAP CER 1 μ F 6.3 V X5R 0402
17	C201	1	1 μ F	C0306	—	LLR185C70G105ME05L	Murata	CAP CER 1 μ F 4 V X7S 0306
18	D1,D14	2	SL44-E3/57T	SL44E357T	—	SL44-E3/57T	Vishay Semiconductor	DIODE SCHOTTKY 40 V 4A DO214AB
19	D3,D10,D25,D26,D27,D28,D29	7	Green	led_0603	—	LTST-C190KGKT	LITE-On INC	LED GREEN CLEAR 0603 SMD
20	D6,D7,D8,D9,D30,D31,D32,D33	8	blue	led_0603	—	LTST-C193TBKT-5A	LITE-On INC	LED BLUE CLEAR 0603 SMD
21	D12	1	0.3VF	MBRA340T3G	—	MBRA340T3G	ON Semi	DIODE SCHOTTKY 40 V 3A SMA
22	D23	1	Red	led_0603	—	LTST-C193KRKT-5A	LITE-On INC	LED RED CLEAR 0603 SMD
23	VCC_DPHY1,VCC_CORE1,VCCIO1,GND1,VCCIO2,GND2,GND3,GND4,GND5,1K_VCCIO0,1K_VCC_CORE1,1K_VCCIO1,1V2,1K_VCCIO2,1K_VCCIO3,TP18,2V5,3V3,5V0,12V0,VCCIO0	21	TP_S_40_63	tp_s_40_63	DNL	—	—	Square test point, 40mil inner diameter, 63mil outer diameter
24	J1	1	header_1x8	hdr_amp_87220_8_1x8_100	—	22-28-4081	Molex	CONN HEADER 8POS .100 VERT TIN
25	J2	1	SKT_MINIUSB_B_RA	skt_miniusb_b_ra	—	5075BMR-05-SM-CR	Neltron	CONN MINI USB RCPT RA TYPE B SMD
26	J3	1	PJ-032A	PJ-032A	—	PJ-032A	CUI Inc.	CONN PWR JACK 2X5.5 MM SOLDER
27	J4,J22	2	73391-0060	73391-0060	—	73391-0060	Molex	CONN SMA RCPT STR 50 Ω PCB
28	J7,J19,J37	3	CON2	CON2	REGULAR 100MIL HEADER	—	—	—

Item	Reference	Qty	Part	PCB Footprint	Comments	PART_NUMBER	Manufacturer	Description
29	J8,J9	2	2 Position Terminal Block_0	TERM_BLOCK_2 POS_10A	—	1727010	Phoenix Contact	TERM BLOCK 2POS 3.81MM PCB GRN
30	J16	1	HEADER 3	header1X3	REGULAR 100MIL HEADER	—	—	General 100 mils Header 1x3
31	J18,J31	2	HEADER 5X2	header2X5	REGULAR 100MIL HEADER	—	—	General 100 Mils 2*5 header
32	J23	1	4 HEADER	CON4	REGULAR 100MIL HEADER	—	—	General 100 mils 4 Position header
33	J24,J25,J26,J27	4	Tri-Con	TriCon	REGULAR 100MIL HEADER	—	—	General 100 mils header
34	J28	1	CON6	HDR1X6	REGULAR 100MIL HEADER	—	—	General 100 mils header
35	J29	1	CON3	HDR1X3	REGULAR 100MIL HEADER/DEFAULT : PIN 2 & 3	—	—	—
36	J32,J35,J36	3	CON3	HDR1X3	REGULAR 100MIL HEADER	—	—	—
37	L1,L2,L3,L4,L5,L6,L7,L9	8	600 Ω 500 mA	FB0603	—	BLM18AG601SN1D	Murata	FERRITE BEAD 600 Ω 0603 1LN
38	L8	1	4.7 uH	MPLC0730L4R7	—	MPLC0730L4R7	Kemet	FIXED IND 4.7 UH 5A 41 MΩ SMD
39	L10,L11,L12	3	120 Ω 1.3 A	FB0402	—	BLM15PD121SN1D	Murata	FERRITE BEAD 120 Ω 0402 1LN
40	MH1,MH2,MH3,MH4, MH5,MH6,MH7,MH8, MH9,MH10	10	ThruHole	MTG125	DNL	-	-	-
41	Q9,Q10,Q11	3	MMBT222 2A	SM_SOT23-3	—	MMBT2222A,215	Nexperia USA Inc.	TRANS NPN 40 V 0.6A SOT23
42	R1,R2,R3,R56,R131,R171, R175,R176,R177,R178, R403,R404,R405,R440, R445,R477,R478,R479, R480,R483,R484,R485, R486	23	4.7 k	R0603	—	CRCW06034K70FKEA	Vishay	RES SMD 4.7 kΩ 1% 1/10W 0603

Item	Reference	Qty	Part	PCB Footprint	Comments	PART_NUMBER	Manufacturer	Description
43	R4,R5,R6,R7,R15,R16, R26,R37,R39,R159,R165, R167,R180,R181,R183, R192,R412,R413,R414, R415,R416,R420,R421, R424,R425,R431,R433, R447,R451,R452,R453, R454,R455,R456,R465, R466,R496	37	0	R0603	—	RC0603JR-070RL	Yageo	RES SMD 0.0 Ω JUMPER 1/10 W 0603
44	R496	37	0	R0603	DNL	RC0603JR-070RL	Yageo	RES SMD 0.0 Ω JUMPER 1/10 W 0603
45	R9,R10	2	2k2	R0603	—	CRCW06032K20FKEA	Vishay	RES SMD 2.2 kΩ 1% 1/10 W 0603
46	R11,R17	2	12 k	R0603	—	RC0603FR-0712KL	Yageo	RES SMD 12 kΩ 1% 1/10 W 0603
47	R12,R13,R14,R123,R124, R125,R395,R399,R400	9	10 K	R0603	—	RMCF0603JT10K0	Stackpole Electronics Inc	RES SMD 10 kΩ 5% 1/10 W 0603
48	R18,R23,R418,R419,R422 ,R423,R481,R482	8	0	R0603	DNL	RC0603JR-070RL	Yageo	RES SMD 0.0 Ω JUMPER 1/10 W 0603
49	R19,R20,R21,R25,R28, R33,R184,R186,R188, R190,R410,R417,R434, R435,R448,R449	16	1	R0603	—	CRCW06031R00JNEAHP	Vishay	RES SMD 1 Ω 5% ¼ W 0603
50	R22,R144	2	4.7 k	R0603	DNL	RC0603JR-074K7L	Yageo	RES SMD 4.7 kΩ 5% 1/10 W 0603
51	R24,R185,R187,R189, R411	5	1	R0603	DNL	CRCW06031R00JNEAHP	Vishay	RES SMD 1 Ω 5% ¼ W 0603
52	R36,R499	2	1 K	R0603	—	RC0603FR-071KL	Yageo	RES SMD 1 kΩ 1% 1/10 W 0603
53	R51,R487,R489,R491	4	100E	R0603	—	RC0603FR07100RL	Yageo	RES SMD 100 Ω 1% 1/10 W 0603
54	R54,R55,R57,R59	4	470E	R0402	—	RC0402FR-07470RL	Yageo	RES SMD 470 Ω 1% 1/16 W 0402
55	R76,R77,R497,R498	4	2 K	R0402	—	ERJ-2RKF2001X	Panasonic	RES SMD 2 kΩ 1% 1/10 W 0402
56	R78	1	10 K	R0402	—	RMCF0402JT10K0	Stackpole Electronics Inc	RES SMD 10 kΩ 5% 1/16 W 0402

Item	Reference	Qty	Part	PCB Footprint	Comments	PART_NUMBER	Manufacturer	Description
57	R80,R500	2	680R	R0402	—	RMCF0402JT680R	Stackpole Electronics Inc	RES SMD 680 Ω 5% 1/16 W 0402
58	R83	1	30E	R0603	—	RC0603FR-0730RL	Yageo	RES SMD 30 Ω 1% 1/10 W 0603
59	R160,R232,R432	3	100 K	R0402	—	ERJ-2RKF1003X	Panasonic	RES SMD 100 kΩ 1% 1/10 W 0402
60	R166,R442,R443,R444	4	1 K	R0402	—	RMCF0402JT1K00	Stackpole Electronics Inc	RES SMD 1 kΩ 5% 1/16 W 0402
61	R229	1	15 K	R0402	—	ERJ-2RKF1502X	Panasonic	RES SMD 15 kΩ 1% 1/10 W 0402
62	R230	1	34 K	R0402	—	ERJ-2RKF3402X	Panasonic	RES SMD 34 kΩ 1% 1/10 W 0402
63	R231	1	536 K	R0402	—	ERJ-2RKF5363X	Panasonic	RES SMD 536 kΩ 1% 1/10 W 0402
64	R233,R436,R437,R438,R439	5	470E	R0603	—	RC0603FR-07470RL	Yageo	RES SMD 470 Ω 1% 1/10 W 0603
65	R441	1	3 K	R0402	—	RC0402FR-073KL	Yageo	RES SMD 3 kΩ 1% 1/16 W 0402
66	R446,R457,R458,R459,R460,R461,R462,R463,R464,R467,R468,R469,R470,R471,R472,R475,R476	17	0	R0402	—	RC0402JR-070RL	Yageo	RES SMD 0.0 Ω JUMPER 1/16 W 0402
67	R450	1	0	R0402	DNL	RC0402JR-070RL	Yageo	RES SMD 0.0 Ω JUMPER 1/16 W 0402
68	R488,R490,R492	3	47 K	R0402	—	RC0402FR-0747KL	Yageo	RES SMD 47 kΩ 1% 1/16 W 0402
69	SW1	1	PWR	TS01CQE_switch	—	TS01CQE	C&K Components	SWITCH SLIDE SPDT 3 A 120 V
70	SW2,SW3,SW4,SW5	4	TL1015AF160QG	2psmd_eswitch	—	TL1015AF160QG	E-Switch	SWITCH TACTILE SPST-NO 0.05 A 12 V
71	U1	1	FT2232HL	tqfp64_0p5_12p2x12p2_h1p6	—	FT2232HL-REEL	FTDI	IC USB HS DUAL UART/FIFO 64-LQFP
72	U2	1	93LC56-SO8	so8_50_244	—	93LC56C-I/SN	Microchip	IC EEPROM 2 KBIT 3 MHz 8SOIC
73	U3	1	FUSE	0154004DRT	—	0154004.DRT	Littelfuse	FUSE BRD MNT 4A 125VAC/VDC 2SMD

Item	Reference	Qty	Part	PCB Footprint	Comments	PART_NUMBER	Manufacturer	Description
74	U5	1	NCP1117S T33T3G	sot223_4p	—	NCP1117ST33T3G	On Semi	IC REG LDO 3.3 V 1 A SOT223
75	U6	1	NCP1117S T25T3G	sot223_4p	—	NCP1117ST25T3G	On Semi	IC REG LDO 2.5 V 1 A SOT223
76	U7,U9,U11,U12	4	Hirose - FX12 - 40 Pos	Hirose-FX12	—	FX12B-40P-0.4SV	Hirose Electric Co Ltd	CONN PLUG 40POS 0.4 MM SMD SHIELD
77	U8	1	LIF- MD6000- 6MG81I	LIFMD6000- csfBGA81	CUSTOMER SUPPLIED	LIF-MD6000-6MG81I	Lattice Semiconductor	LATTCE CROSSLNK - NTERFACE MP D-
78	U14	1	M25PX16- VMW6TG	SOIC8	—	M25PX16-VMW6TG TR	Micron Technology Inc	IC FLASH 16 MBIT 75 MHZ 8SO
79	U15	1	AP7313- 12SAG-7	SOT23	—	AP7313-12SAG-7	Diodes Inc	IC REG LDO 1.2 V 0.15 A SOT-23
80	U17	1	NCP1117S T18T3G	sot223_4p	—	NCP1117ST18T3G	On Semi	IC REG LDO 1.8 V 1 A SOT223
81	U18	1	LT3680	LT3680_10QFN	—	LT3680EDD#PBF	Linear Technology	IC REG BUCK ADJ 3.5 A 10DFN
82	U19	1	LCMXO3LF -1300E- 5MG121C	LCMXO3LF- 1200E-MG121	CUSTOMER SUPPLIED	LCMXO3LF-1300E- 5MG121C	Lattice Semiconductor	IC FPGA 100 I/O 121CSFBGA
83	U20	1	ESDR0502 N	ESDR0502N	—	ESDR0502NMUTBG	ON Semiconductor	TVS DIODE 5.5 VWM 6UDFN
84	U21	1	STG3693Q TR	STG3693QTR	—	STG3693QTR	STMicroelectronics	IC SWITCH QUAD SPDT 16QFN
84	X1	1	12 MHz	crystal_4p_3p2x 2p5	—	7M-12.000MAAJ-T	TXC	CRYSTAL 12.0000 MHz 18 PF SMD
85	X3,X4	2	KC3225A2 7.0000C30 EOA	27MHZ_OSC	—	KC3225A27.0000C30EOA	AVX Corporation	Standard Clock Oscillators 27.000 MHz
86	CrossLink Master Multi- Link Board Rev1 PCB	1	—	—	—	305-PD-17-0273	PACTRON	—

Appendix C. SMA-IOL-EVN-BRD Schematics

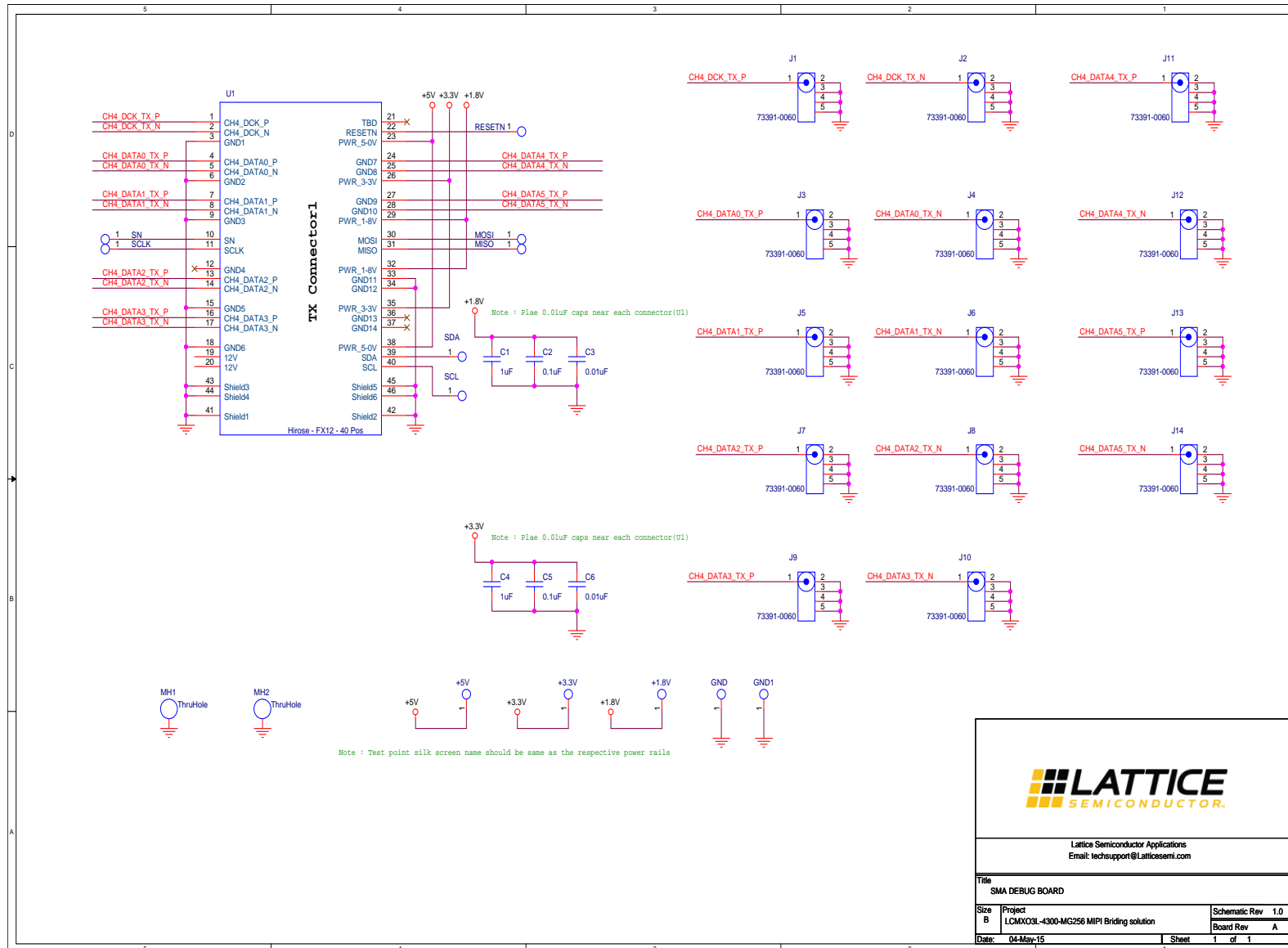

SMA Debug Board

Appendix D. SMA-IOL-EVN-BRD Bill of Materials

SMA IO Link Board Bill of Materials

Item	Reference	Qty	Part	PCB Footprint	Comments	PART_NUMBER	Manufacturer	Description
1	GND1, +5 V, +1.8 V, +3.3 V, SN, SDA, SCLK, SCL, RESETN, MOSI, MISO, GND	12	TP_S_40_63	tp_s_40_63	DNI	—	—	Square test point, 40 mil inner diameter, 63 mil outer diameter
2	C1, C4	2	1 μ F	C0402	—	C0402C105K9PACTU	Kemet	CAP CERAMIC 1 μ F 6.3 V X5R 0402
3	C2, C5	2	0.1 μ F	C0402	—	C0402C104K4RACTU	Kemet	CAP CERAMIC 0.1 μ F 16 V X7R 0402
4	C3, C6	2	0.01 μ F	C0402	—	C0402C103J4RACTU	Kemet	CAP CERAMIC 10 nF 16 V 5% X7R 0402
5	J1, J2, J3, J4, J5, J6, J7, J8, J9, J10, J11, J12, J13, J14	14	73391-0060	73391-0060	—	73391-0060	Molex	Molex Straight 500 Through Hole SMA Connector, jack, Solder Termination
6	MH1, MH2	2	Thru Hole	MTG125	—	—	—	—
7	U1	1	Hirose - FX12 - 40 Pos	Hirose-FX12S	—	FX12B-40S-0.4SV	Hirose Electric Co Ltd	Conn Board to Board PL 40 POS 0.4 mm Solder ST SMD T/R
8	SMA IOLINK BOARD PCB	1	—	—	—	305-PD-15-0589	PACTRON	—

Appendix E. B-IOL-EVN-BRD Schematics

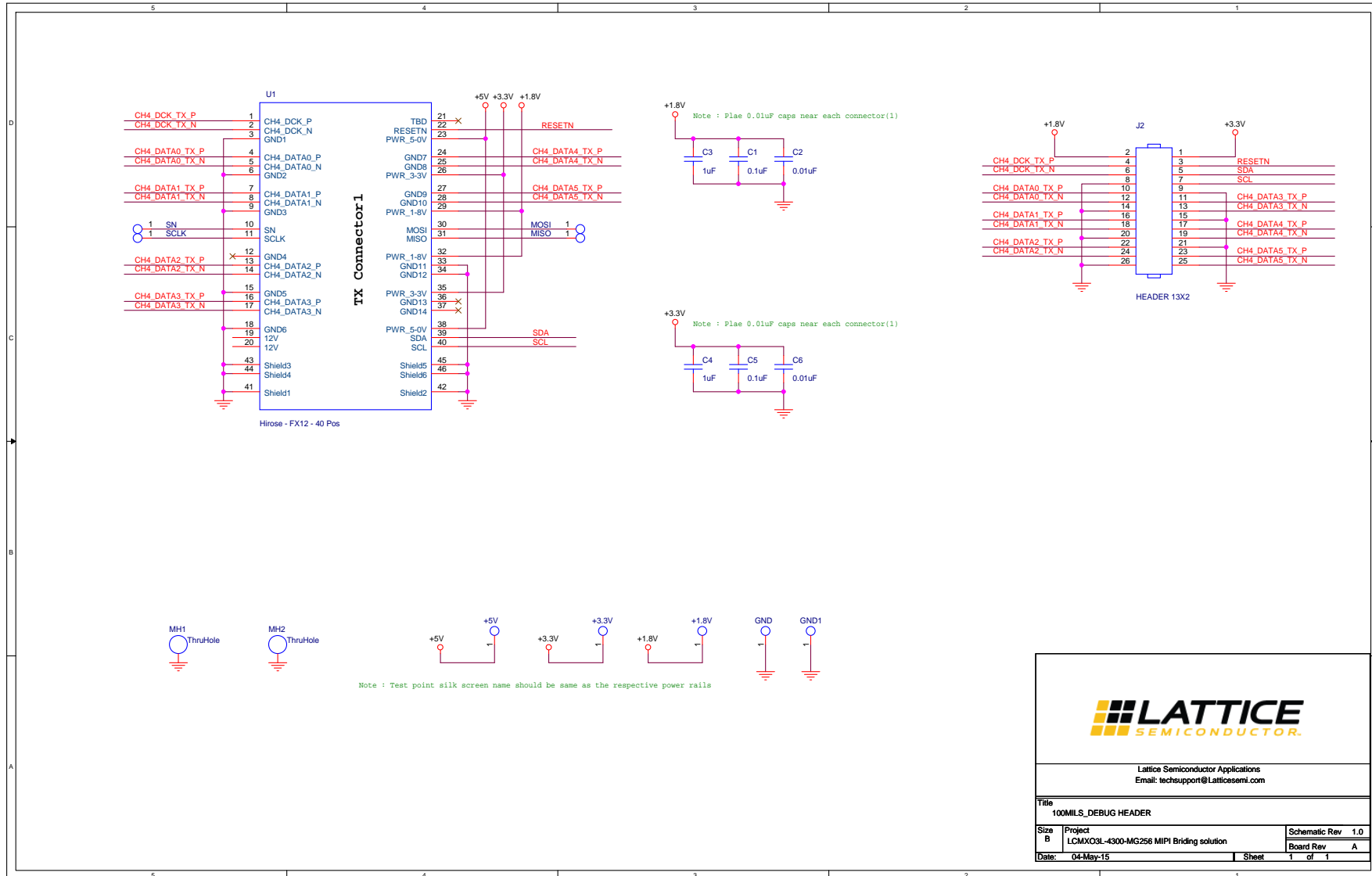

100MILS_DEBUG Header

Appendix F. B-IOL-EVN-BRD Bill of Materials

Breakout IO Link Board Bill of Materials

Item	Reference	Qty	Part	PCB Footprint	Comments	Part_ Number	Manufacturer	Description
1	GND1, +5 V, +1.8 V, +3.3 V, SN, SCLK, MOSI, MISO, GND	9	TP_S_40_63	tp_s_40_63	DNL	—	—	Square test point, 40 mil inner diameter, 63 mil outer diameter
2	C1, C5	2	0.1 μ F	C0402	—	C0402C104K4RACTU	Kemet	CAP CERAMIC 0.1 μ F 16 V X7R 0402
3	C2, C6	2	0.01 μ F	C0402	—	C0402C103J4RACTU	Kemet	CAP CERAMIC 10 nF 16 V 5% X7R 0402
4	C3, C4	2	1 μ F	C0402	—	C0402C105K9PACTU	Kemet	CAP CERAMIC 1 μ F 6.3 V X5R 0402
5	J2	1	HEADER 13X2	13X2_HDR	REGULAR 100 MIL HEADER	—	—	—
6	MH1, MH2	2	ThruHole	MTG125	DNL	—	—	—
7	U1	1	Hirose - FX12 - 40 Pos	Hirose-FX12S	—	FX12B-40S-0.4SV	Hirose Electric Co Ltd	Conn Board to Board PL 40 POS 0.4 mm Solder ST SMD T/R
8	BREAKOUT IOLINK BOARD PCB	1	—	—	—	305-PD-15-0595	PACTRON	—

Revision History

Date	Version	Change Summary
June 2018	1.0	Initial release.



7th Floor, 111 SW 5th Avenue
Portland, OR 97204, USA
T 503.268.8000
www.latticesemi.com