

# **SAM3N-EK Development Board**

---

## **User Guide**



---

## **Section 1**

Introduction .....	1-1
1.1 SAM3N Evaluation Kit .....	1-1
1.2 User Guide .....	1-1
1.3 References and Applicable Documents .....	1-1

---

## **Section 2**

Kit Contents .....	2-1
2.1 Deliverables .....	2-1
2.2 Electrostatic Warning .....	2-2

---

## **Section 3**

Power Up .....	3-1
3.1 Power up the Board .....	3-1
3.2 DevStart .....	3-1
3.3 Recovery Procedure .....	3-1
3.4 Sample Code and Technical Support .....	3-1

---

## **Section 4**

Evaluation Kit Hardware .....	4-1
4.1 Board Overview .....	4-1
4.2 Features List .....	4-2
4.3 Function Blocks .....	4-2
4.3.1 Processor .....	4-2
4.3.2 Memory .....	4-2
4.3.3 Clock Circuitry .....	4-3
4.3.4 Reset Circuitry .....	4-3
4.3.5 Power Supply and Management .....	4-4
4.3.6 UART .....	4-4
4.3.7 Display Interface .....	4-5
4.3.8 Backlight Control .....	4-5
4.3.9 JTAG/ICE .....	4-6
4.3.10 PWM Buzzer .....	4-6
4.3.11 SD/MMC Card .....	4-6
4.3.12 Touch Elements .....	4-7
4.3.13 User Buttons .....	4-7
4.3.14 LEDs .....	4-8
4.3.15 ZigBee .....	4-8
4.3.16 PIO Expansion .....	4-8
4.4 Configuration .....	4-9
4.4.1 PIO Usage .....	4-9

4.4.2	Jumpers .....	4-12
4.4.3	Test Points .....	4-12
4.4.4	Assigned PIO Lines, Disconnection Possibility .....	4-13

---

## **Section 5**

QT600.....		5-1
5.1	Overview .....	5-1
5.2	System Description .....	5-2
5.3	Features .....	5-2
5.4	Getting Started .....	5-3
5.5	Hardware Description.....	5-5
5.5.1	QT600 Interface Board .....	5-5
5.5.2	TOUCH DATA Connectors .....	5-7
5.5.3	Target Voltage VTG .....	5-8
5.5.4	VTG LED .....	5-8
5.5.5	TOUCH DATA LED .....	5-8
5.5.6	STATUS LED.....	5-9
5.5.7	Touch ATx Firmware .....	5-9
5.6	Touch Debug.....	5-9
5.7	Using QT600 and AVR QTouch Studio for Custom Applications.....	5-9
5.8	Troubleshooting and Support.....	5-10
5.8.1	Technical Support.....	5-10
5.8.2	Force Firmware Upgrade .....	5-10

---

## **Section 6**

Schematics .....		6-1
6.1	Schematics.....	6-1

---

## **Section 7**

Troubleshooting .....		7-1
7.1	Self-Test.....	7-1
7.2	Board Recovery .....	7-1

---

## **Section 8**

Revision History.....		8-1
8.1	Revision History .....	8-1





# Section 1

## Introduction

### 1.1 SAM3N Evaluation Kit

The SAM3N Evaluation Kit (SAM3N-EK) allows the evaluation of the SAM3N series devices. It has enough features to demonstrate most of the product's capabilities to the users. The SAM3N-EK also features extension connectors to allow the users to add new interfaces in case they are not on-board.

### 1.2 User Guide

This guide focuses on the SAM3N-EK board as an evaluation platform. It is made up of 6 sections:

- Section 1 includes references, applicable documents, acronyms and abbreviations.
- Section 2 summarizes the kit contents.
- Section 3 provides instructions to power up the SAM3N-EK and describes how to use it.
- Section 4 describes the SAM3N-EK board design in more detail.
- Section 5 provides schematics.
- Section 6 describes the troubleshooting.

### 1.3 References and Applicable Documents

**Table 1-1.** References and Applicable Documents

Title	Comment
SAM3N Datasheet	<a href="http://atmel.com/dyn/products/devices.asp?family_id=605#2245">http://atmel.com/dyn/products/devices.asp?family_id=605#2245</a>



## Section 2

# Kit Contents

### 2.1 Deliverables

The Atmel® SAM3N Evaluation Kit contains the following items:

- a SAM3N-EK board
- a universal input AC/DC power supply with US, Europe and UK plug adapters
- one serial RS232 cable
- a welcome letter

**Figure 2-1.** Unpacked SAM3N-EK



Unpack and inspect the kit carefully. Contact your local Atmel distributor, should you have issues concerning the contents of the kit.

---

## **2.2 Electrostatic Warning**

The SAM3N-EK board must not be subjected to high electrostatic potentials. A grounding strap or similar protective device should be worn when handling the board. Avoid touching the components or any other metallic element of the board.



### 3.1 Power up the Board

Unpack the board taking care to avoid electrostatic discharge. Unpack the power supply, select the right power plug adapter corresponding to that of your country, and insert it in the power supply.

Connect the power supply DC connector to the board and plug the power supply to an AC power plug. The board LCD should light up and run a Touch demo (shows a screen animation that matches the Touch devices operated on the PCB).

### 3.2 DevStart

The CDROM provided in the kit contains what we call a "DevStart" a.k.a. "Development Start". This bundle guides you through the first steps of building and running a software application on the SAM3N-EK.

If the CD does not auto-play on your PC, just open it through the explorer and click the file welcome.html to get started.

The SAM3N-EK DevStart guides you through the installation processes of IAR™ EWARM, Keil MDK and GNU toolkits. Then, it gives you step-by-step instructions on how to rebuild a single example project and how to program it into the SAM3N-EK. Optionally, if you have a SAM-ICE™, instructions are also given about how to debug the code.

### 3.3 Recovery Procedure

The DevStart ends by giving step-by-step instructions on how to recover the SAM3N-EK to the state as it was when shipped by Atmel.

SAM3N-EK Test Software, Chapter 3.1 "Flash Recovery" gives instructions if you deleted the contents of the embedded Flash or the DataFlash® and want to recover from this situation.

### 3.4 Sample Code and Technical Support

After boot up, you can run some sample code or your own application on the development kit. You can download sample code and get technical support from Atmel website (<http://support.atmel.no/bin/customer>).

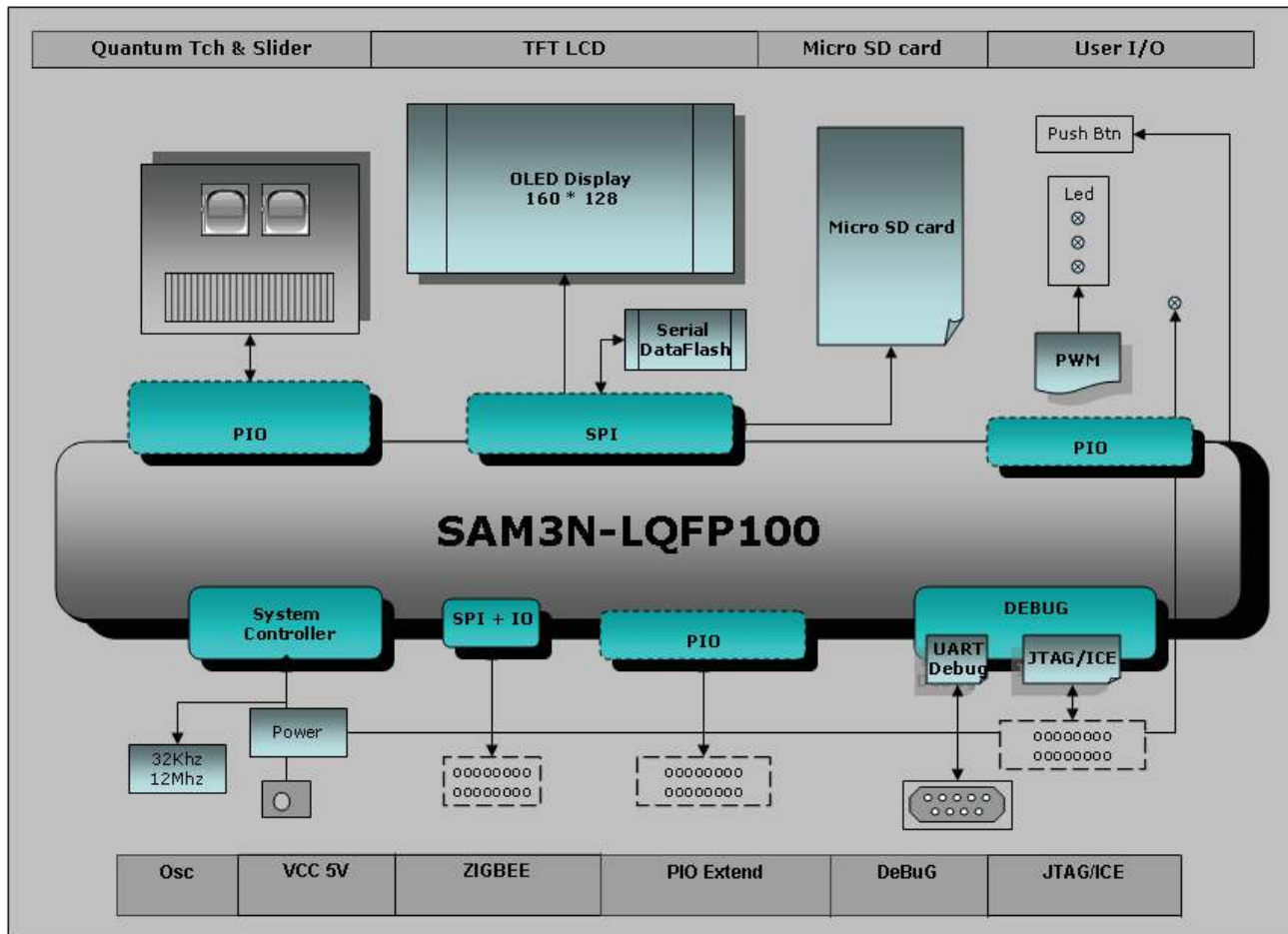
## Evaluation Kit Hardware

### 4.1 Board Overview

This section introduces the Atmel SAM3N Evaluation Kit design. It introduces system-level concepts, such as power distribution, memory, and interface assignments.

The SAM3N-EK board is based on the integration of an ARM® Cortex®-M3 processor with on-board Flash and a set of popular peripherals. It is designed to provide a high performance processor evaluation solution with high flexibility for various kinds of applications.

Figure 4-1. SAM3N-EK Block Diagram





## 4.2 Features List

Here is the list of the main board components and interfaces:

- SAM3N4C QFP chip with optional socket footprint
- 12 MHz crystal
- 32.768 KHz crystal
- 32-Megabit Serial DataFlash
- 2.0 inch TFT color LCD display with backlight
- UART port with level shifter IC
- Micro SD interface
- Reset buttons: NRST
- User buttons: Left and Right
- QTouch® buttons: Left, Right, and Slider
- JTAG port
- On-board power regulation
- Two user LEDs
- Power LED
- ZigBee® connector
- 2x32 bit PIO connection interfaces (PIOA, PIOC) and 1x15 bit PIO connection interface (PIOB)

## 4.3 Function Blocks

### 4.3.1 Processor

The SAM3N-EK is equipped with a SAM3N4C device in LQFP100 package.

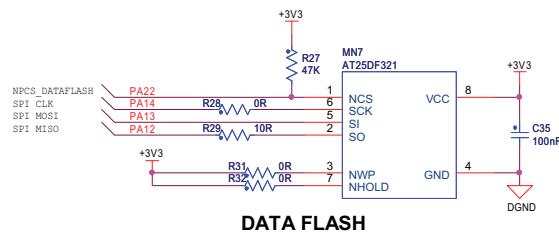
### 4.3.2 Memory

The SAM3N4 chip embeds:

- 256 Kbytes of embedded Flash
- 24 Kbytes of embedded SRAM with dual bank
- 16 Kbytes of ROM with embedded BootLoader routines (UART) and In-Application Programming functions (IAP) routines.

The SAM3N-EK features an external DataFlash through SPI bus

**Figure 4-2.** DataFlash



NPCS3 chip select signal is used for DataFlash chip selection.

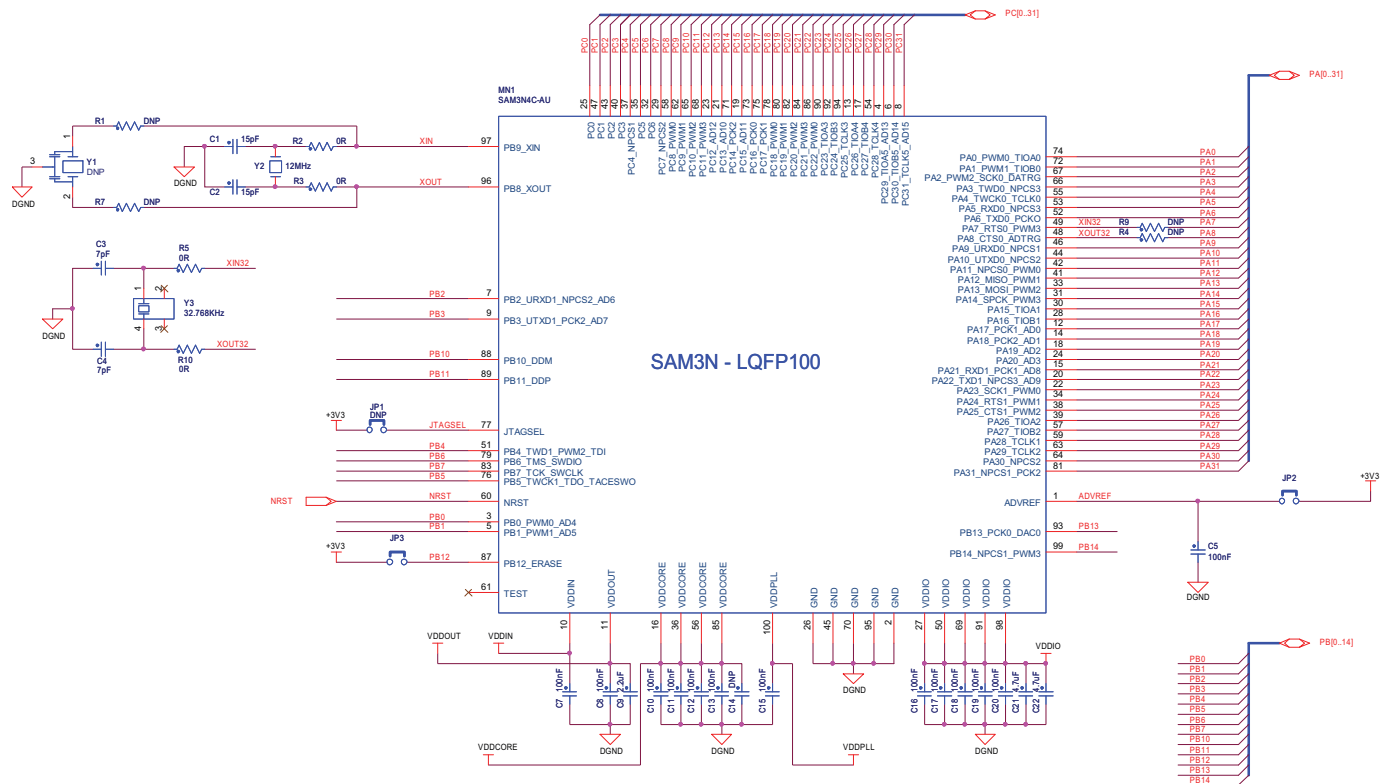
### 4.3.3 Clock Circuitry

The clock generator of a SAM3N microcontroller is made up of:

- A Low Power 32,768 Hz Slow Clock Oscillator with bypass mode
- A Low Power RC Oscillator
- A 3 to 20 MHz Crystal Oscillator, which can be bypassed
- A factory programmed fast internal RC Oscillator. 3 output frequencies can be selected: 4 (default value), 8 or 12 MHz.
- A 60 to 130 MHz programmable PLL (input from 3.5 to 20 MHz), capable to provide the clock MCK to the processor and to the peripherals.

The SAM3N-EK board is equipped with one 12 MHz crystal, and one 32.768 Hz crystal. An optional 12 MHz Piezoelectric Ceramic Resonator can be mounted in place of the 12 MHz crystal (for low cost clocking option evaluation).

Figure 4-3. SAM3N MCU



### 4.3.4 Reset Circuitry

The on-board NRST button BP1 provides the SAM3N4C with external reset control.

Two User buttons BP2 and BP3, can be used to wake up the chip from low power modes.

The NRST pin is bidirectional. It is handled by the on-chip reset controller. It can be driven low to provide a reset signal out to the external components. Conversely, it can be asserted low from the outside to reset the microcontroller, its core and peripherals, with exception of the backup region (RTC, RTT and



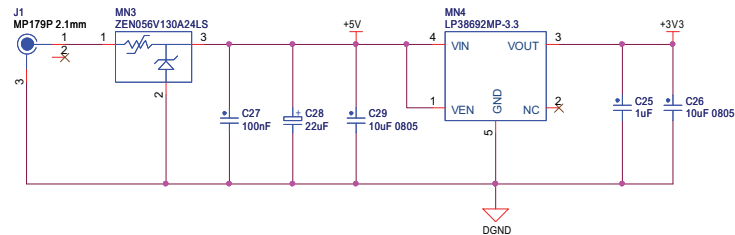
Supply Controller). The NRST pin integrates a permanent pull-up resistor of about 100 kOhm to VDDIO. On the SAM3N-EK board, the NRST signal is connected to the JTAG port.

#### 4.3.5 Power Supply and Management

The SAM3N-EK board is supplied with an external 5V DC block through the J1 socket. It is protected by a PolyZen diode MN3. The PolyZen protects the board in the case of an incorrect power supply connection.

The LDO regulator MN4 is used for the 3.3V main supply. It powers all the 3.3V components on the board.

**Figure 4-4.** Power Block



The SAM3N4/2/1 product series has different types of power supply pins:

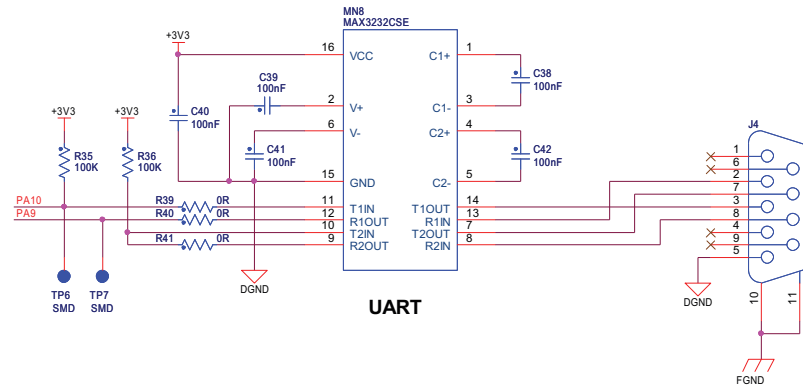
- VDDIN pin: Power for the internal voltage regulator, ADC, DAC, and analog comparator power supplies. This voltage ranges from 1.8V to 3.6V.
- VDDIO pin: Powers the Peripheral I/O lines, Backup part, 32 kHz crystal oscillator and oscillator pads. This voltage ranges from 1.62V to 3.6V.
- VDDOUT pin: Output of the internal voltage regulator.
- VDDCORE pin: Powers the core, including the processor, the embedded memories and the peripherals. This voltage ranges from 1.62V to 1.95V.
- VDDPLL pin: Powers the PLL, the Fast RC and the 3 to 20 MHz oscillators. This voltage ranges from 1.62V to 1.95V.

#### 4.3.6 UART

The Universal Asynchronous Receiver Transmitter features a two-pin UART that can be used for communication and trace purposes. It offers an ideal channel for in-situ programming solutions. This UART is associated with two PDC channels to reduce the processor time on packet handling.

The two-pin UART (TXD and RXD only) is buffered through an RS232 Transceiver MN8 and brought to the DB9 male connector J4.

Figure 4-5. UART

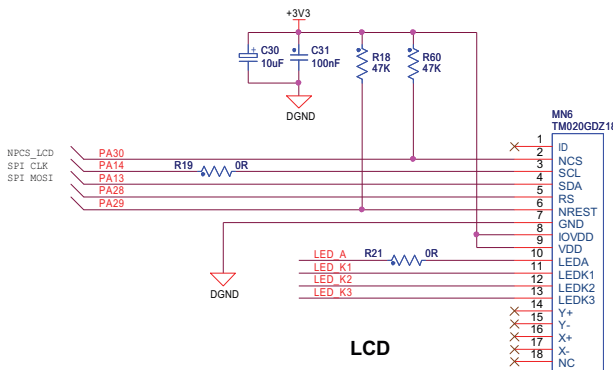


### 4.3.7 Display Interface

The SAM3N-EK carries a TFT Transmissive LCD module with touch panel, TM020GDZ18. Its integrated driver IC is ILI9225B. The LCD display area is 2.0 inches diagonally measured, with a native resolution of 176x220 pixels.

The LCD module gets reset from GPIO PA29. The LCD chip select signal is connected to NPCS2. The SAM3N communicates with the LCD through the SPI bus.

Figure 4-6. LCD

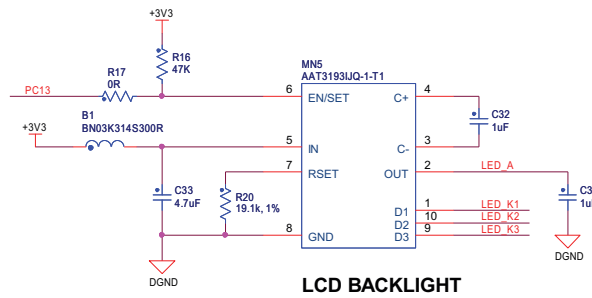


### 4.3.8 Backlight Control

The LCD backlight is made of four integrated white chip-LEDs arranged in parallel. These are driven by an AAT3193 charge pump, MN5. The AAT3193 is controlled by the SAM3N through a single PIO line interface (PC13); the 0 Ohm resistor R17 is mounted in series on this line, which permits to use it for other custom purposes. In that case, the pull-up resistor R64 maintains the charge pump permanently enabled by default.

On the anode drive line, a 0 Ohm resistor R21 is implemented in series for an optional current limitation.

Figure 4-7. Backlight

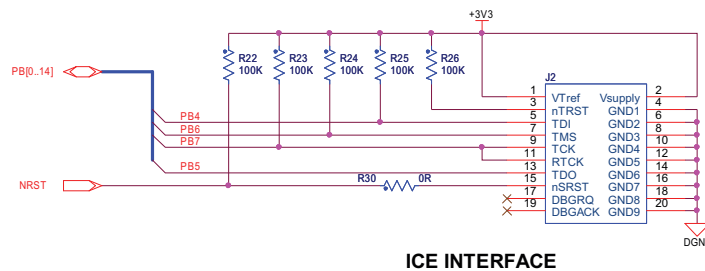


### 4.3.9 JTAG/ICE

A standard 20-pin JTAG/ICE connector is implemented on the SAM3N-EK for the connection of a compatible ARM JTAG emulator interface, such as the SAM-ICE from Segger.

- Notes:**
1. The NRST signal is connected to BP1 system button. The 0 ohm resistor R30 may be removed in order to isolate the JTAG port from this system reset signal.
  2. The TDO pin is in input mode with the pull-up resistor disabled when the Cortex M3 is not in debug mode. To avoid current consumption on VDDIO and/or VDDCORE due to floating input, the internal pull-up resistor corresponding to this PIO line must be enabled.

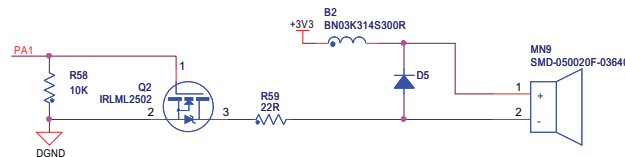
Figure 4-8. JTAG Connector



### 4.3.10 PWM Buzzer

A small, magnetic audio transducer connects through a MOSFET to PWM, allowing a range of options for generating simple and complex tones.

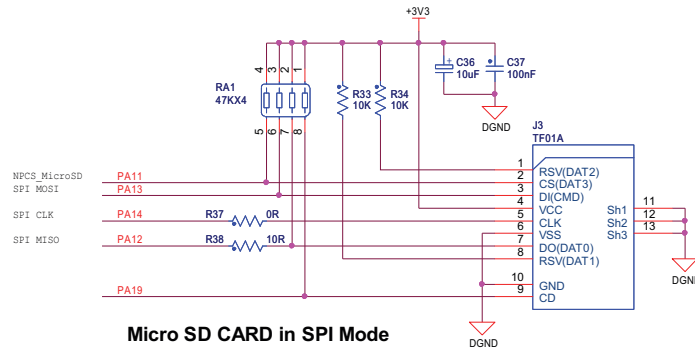
Figure 4-9. PWM Buzzer



### 4.3.11 SD/MMC Card

The SAM3N has a high-speed 4-bit multimedia MMC interface, which is connected to a 4-bit SD/MMC micro card slot featuring a card detection switch.

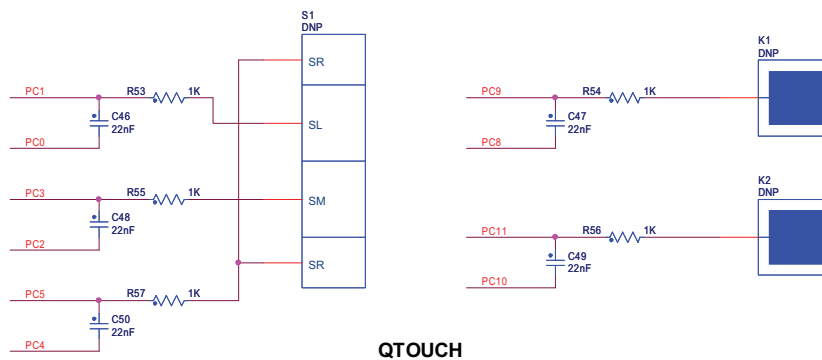
Figure 4-10. SD Card



#### 4.3.12 Touch Elements

QTouch keys consist of a series of sensors formed by the association of a copper area and the capacitive effect of human fingers approaching it.

Figure 4-11. QTouch Elements



##### ■ Keys

The SAM3N-EK implements two individual capacitive touch keys (RIGHT, LEFT) using two pairs of PIOs.

##### ■ Slider

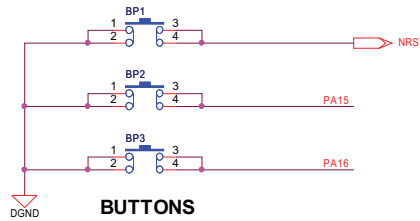
A group of channels forms a Slider. A Slider is composed of three channels for a QTouch acquisition method using three pairs of PIOs. Such a sensor is used to detect a linear finger displacement on a sensitive area. A typical slider implementation is volume control.

#### 4.3.13 User Buttons

There are two mechanical user buttons on the SAM3N-EK, which are connected to PIO lines and defined to be "left" and "right" buttons by default.

In addition, a mechanical button controls the system reset, signal NRST.

Figure 4-12. User Buttons

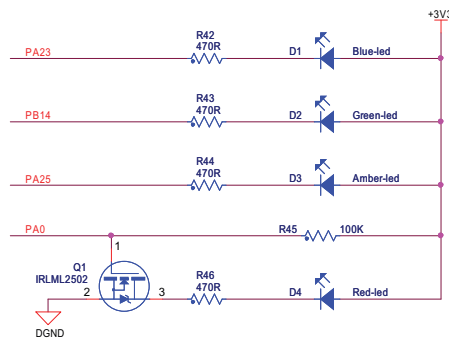


#### 4.3.14 LEDs

There are four LEDs on the SAM3N-EK board:

- A blue LED (D1), a green LED (D2), and an amber LED (D3) which are user-defined and controlled by the GPIO.
- A red LED (D4), which is a power LED indicating that the 3.3V power rail is active. It is also controlled by the GPIO and can be treated as a user LED as well. The only difference with the three others is that it is controlled through a MOS transistor. By default, the PIO line is disabled; a pull-up resistor controls the MOS to light the LED when the power is ON.

Figure 4-13. LEDs

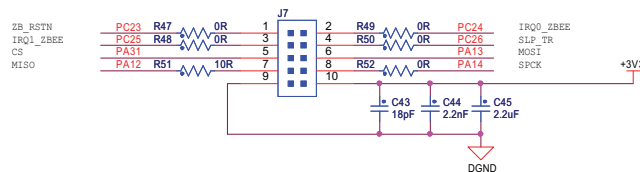


#### 4.3.15 ZigBee

SAM3N-EK has a 10-pin male connector for the RZ600 ZigBEE module.

**Note:** 0 Ohm resistors have been implemented in series with the PIO lines that are used elsewhere in the design, thereby enabling their individual disconnection, should a conflict occur in your application.

Figure 4-14. ZigBee



#### 4.3.16 PIO Expansion

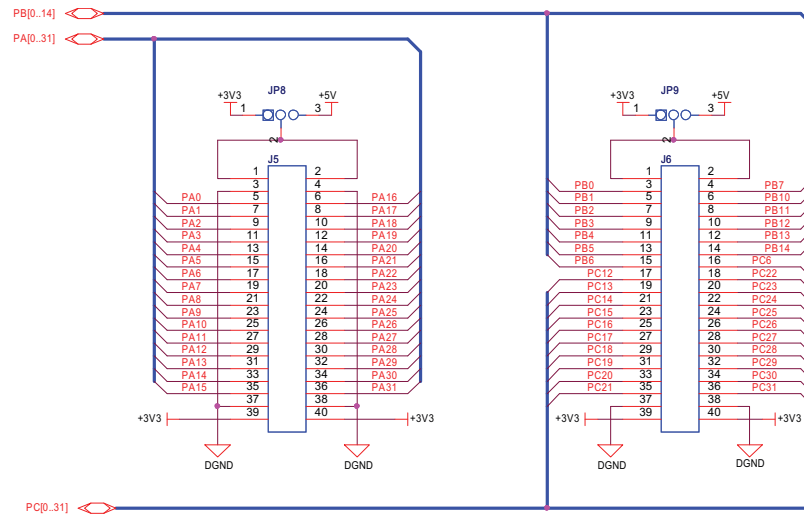
The SAM3N product features three PIO controllers, PIOA, PIOB and PIOC, which are multiplexed with the I/O lines of the embedded peripherals. Each PIO Controller controls up to 32 lines (15 for PIOB).

Expansion ports J5, J6 provide PIO lines access for customer defined usage.



**Note:** All PIO lines are available on these expansion connectors, except those that are used for the QTouch elements.

**Figure 4-15.** PIO Expansion



## 4.4 Configuration

This section describes the PIO usage, the jumpers, the test points and the solder drops of a SAM3N-EK board.

### 4.4.1 PIO Usage

**Table 4-1.** PIO Port A Assignment

I/O Line	Peripheral A	Peripheral B	Peripheral C	Extra Function	EK Usage	Device
PA0	PWM0	TIOA0		WKUP00	POWER LED	Led Red
PA1	PWM1	TIOB0		WKUP01	CMD_SOUND	BUZZER
PA2	PWM2	SCK0	DATRG	WKUP02		
PA3	TWD0	NPCS3		WKUP03		
PA4	TWCK0	TCLK0				
PA5	RXD0	NPCS3		WKUP04		
PA6	TXD0	PCK0				
PA7	RTS0	PWM3			XIN32	32K Crystal
PA8	CTS0	ADTRG		WKUP05	XOUT32	32K Crystal
PA9	URXD0	NPCS1		WKUP06	RX_UART0	UART
PA10	UTXD0	NPCS2			TX_UART0	UART
PA11	NPCS0	PWM0		WKUP07	SPI_NPCS0#	MicroSD





**Table 4-1.** PIO Port A Assignment (Continued)

I/O Line	Peripheral A	Peripheral B	Peripheral C	Extra Function	EK Usage	Device
PA12	MISO	PWM1			SPI_MISO	LCD MicroSD DataFlash Zigbee
PA13	MOSI	PWM2			SPI_MOSI	LCD MicroSD DataFlash Zigbee
PA14	SPCK	PWM3		WKUP08	SPI_SPCK	LCD MicroSD DataFlash Zigbee
PA15		TIOA1		WKUP14	PB_LEFT#	Push Button Left
PA16		TIOB1		WKUP15	PB_RIGHT#	Push Button Right
PA17		PCK1		AD0		
PA18		PCK2		AD1		
PA19				AD2/ WKUP09	MicroSD_CD	MicroSD
PA20				AD3/ WKUP10		
PA21	RXD1	PCK1		AD8		
PA22	TXD1	NPCS3		AD9	SPI_NPCS3#	DataFlash
PA23	SCK1	PWM0			USR_LED1#	Led Blue
PA24	RTS1	PWM1				
PA25	CTS1	PWM2			USR_LED3#	Led Amber
PA26		TIOA2				
PA27		TIOB2				
PA28		TCLK1			RS_LCD	LCD
PA29		TCLK2			RST_LCD	LCD
PA30		NPCS2		WKUP11	SPI_NPCS2#	LCD
PA31	NPCS1	PCK2			SPI_NPCS1#	ZigBee

**Table 4-2.** PIO Port B Assignment

I/O Line	Peripheral A	Peripheral B	Peripheral C	Extra Function	EK Usage	Device
PB0	PWM0			AD4		
PB1	PWM1			AD5		
PB2	URXD1	NPCS2		AD6/ WKUP12		
PB3	UTXD1	PCK2		AD7		
PB4	TWD1	PWM2			TDI	JTAG
PB5	TWCK1			WKUP13	TDO/ TRACESWO	JTAG



**Table 4-2.** PIO Port B Assignment (Continued)

I/O Line	Peripheral A	Peripheral B	Peripheral C	Extra Function	EK Usage	Device
PB6					TMS/SWDIO	JTAG
PB7					TCK/SWCLK	JTAG
PB8					XOUT_12M	12M Crystal
PB9					XIN_12M	12M Crystal
PB10						
PB11						
PB12					ERASE	JUMPER
PB13		PCK0		DAC0		
PB14	NPCS1	PWM3			USR_LED2#	Led Green

**Table 4-3.** PIO Port C Assignment

I/O Line	Peripheral A	Peripheral B	Peripheral C	Extra Function	EK Usage	Device
PC0					QT_SL_SNS	QTOUCH_SLIDER
PC1					QT_SL_SNSK	QTOUCH_SLIDER
PC2					QT_SM_SNS	QTOUCH_SLIDER
PC3					QT_SM_SNSK	QTOUCH_SLIDER
PC4		NPCS1			QT_SR_SNS	QTOUCH_SLIDER
PC5					QT_SR_SNSK	QTOUCH_SLIDER
PC6						
PC7		NPCS2				
PC8		PWM0			QT1_SNS	QTOUCH_KEY_Left
PC9		PWM1			QT1_SNSK	QTOUCH_KEY_Left
PC10		PWM2			QT2_SNS	QTOUCH_KEY_Right
PC11		PWM3			QT2_SNSK	QTOUCH_KEY_Right
PC12				AD12		
PC13				AD10	EN_LCD	LCD
PC14		PCK2				
PC15				AD11		
PC16		PCK0				
PC17		PCK1				
PC18		PWM0				
PC19		PWM1				
PC20		PWM2				
PC21		PWM3				
PC22		PWM0		AD16		
PC23		TIOA3			ZB_RSTN	ZigBee

**Table 4-3.** PIO Port C Assignment (Continued)

I/O Line	Peripheral A	Peripheral B	Peripheral C	Extra Function	EK Usage	Device
PC24		TIOB3			ZB_IRQ0	ZigBee
PC25		TCLK3			ZB_IRQ1	ZigBee
PC26		TIOA4			ZB_SLPTR	ZigBee
PC27		TIOB4				
PC28		TCLK4				
PC29		TIOA5		AD13		
PC30		TIOB5		AD14		
PC31		TCLK5		AD15		

#### 4.4.2 Jumpers

The SAM3N-EK board jumpers are used for many purposes such as internal Flash Memory reinitialization, power current measurement and other configurations.

**Table 4-4.** Jumpers

Designation	Label	Default Setting	Feature
JP1	JTAGSEL	OPEN	Close it to reinitialize the Flash content and some of its NVM bits. This jumper must be closed for more than 220 ms at power-up to perform the reinitialization.
JP2	ADVREF	CLOSE	Analog reference voltage selection, access for external reference voltage
JP3	PB12	OPEN	ERASE, Close to reinitialize the Flash contents and some of its NVM bits
JP4	VDDIO	CLOSE	Access for current measurement on VDDIO
JP5	VDDIN	CLOSE	Access for current measurement on VDDIN
JP6	VDDPLL	CLOSE	Access for current measurement on VDDPLL
JP7	VDDCORE	CLOSE	Access for current measurement on VDDCORE
JP8	+3V3	1-2	DC voltage selection between 3.3V and 5V on PIO expansion ports, default for 3.3V
JP9	+3V3	1-2	DC voltage selection between 3.3V and 5V on PIO expansion ports, default for 3.3V

#### 4.4.3 Test Points

Some test points have been placed on the SAM3N-EK board for the verification of important signals.

**Table 4-5.** Test Points

Designation	Part	Description
TP1	Ring Hook	+5V
TP2	Ring Hook	+3V3
TP3	Ring Hook	GND
TP4	Ring Hook	GND

**Table 4-5.** Test Points (Continued)

Designation	Part	Description
TP5	Ring Hook	GND
TP6	Pad	UTXD0
TP7	Pad	URXD0

#### 4.4.4 Assigned PIO Lines, Disconnection Possibility

As pointed out in previous interface descriptions, 0-Ohm resistors have been inserted on the PIO lines receiver path of the SAM3N-EK. Some PIO lines are connected to an external driver on the board. The 0-Ohm resistors allow disconnecting each of these for custom usage (through PIO expansion connectors, for example). This feature gives the user an added level of versatility for prototyping a system of his own. See the table below.

**Table 4-6.** Disconnection Possibility

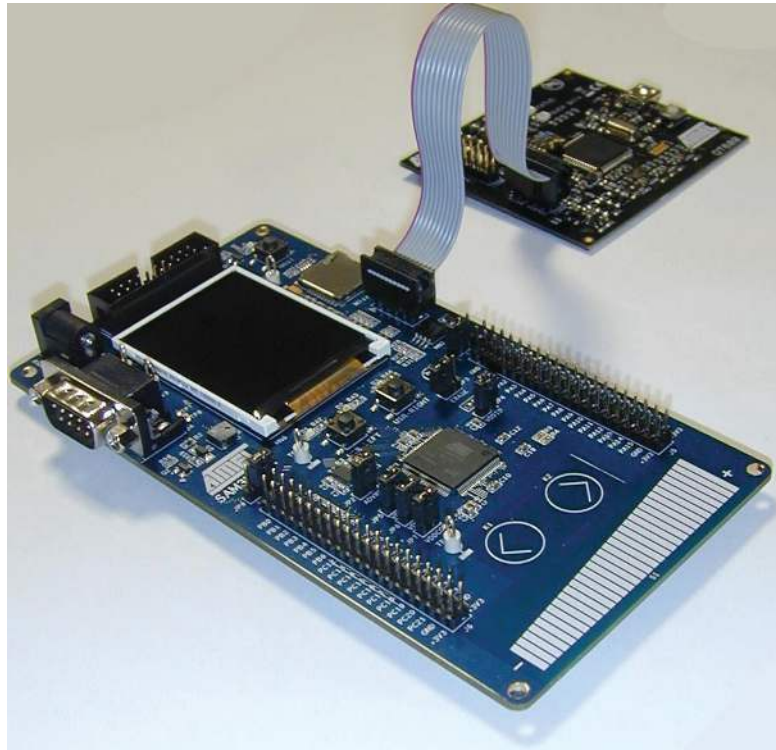
Designation	Default Assignment	PIO
R2	XIN	PB9
R3	XOUT	PB8
R9, R5	XIN32	PA7
R4, R10	XOUT32	PA8
R17	EN_LCD	PC13
R39	URXD0	PA9
R40	UTXD0	PA10
R47	ZB_RSTN	PC23
R48	IRQ1_ZBEE	PC25
R49	IRQ0_ZBEE	PC24
R50	SLP_TR	PC26

#### 5.1 Overview

The QT600 is an integrated board added in the kit that allows you to develop and debug any application using the Atmel QTouch Library™. QT600 has been designed to give developers a quick and easy way to start developing touch solutions on Atmel ATx Microcontrollers.

QT600 is fully supported by QTouch Library and AVR Studio®, and together these tools form the Atmel QTouch Suite™.

**Figure 5-1.** SAM3N-EK and QT600 Connection

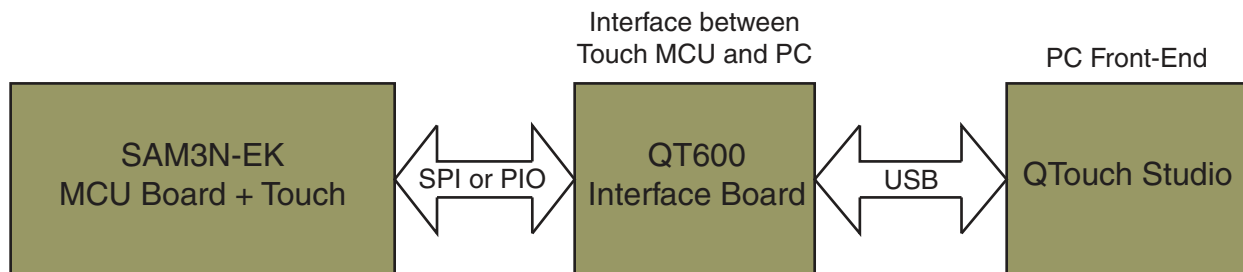


## 5.2 System Description

The development system is based on two boards connected together:

- QT600 Interface Board
- SAM3N-EK Board with Touch Sensor

**Figure 5-2.** QT600 System Block Diagram



The QT600 Interface board is used to stream live touch data from the SAM3N-EK board. QTouch Studio™ is used as the PC front-end, for visualization of the touch data.

## 5.3 Features

- Live streaming of touch data to QTouch Studio
- USB Interface to PC for programming and streamed QTouch Debug data
- Powered from USB bus

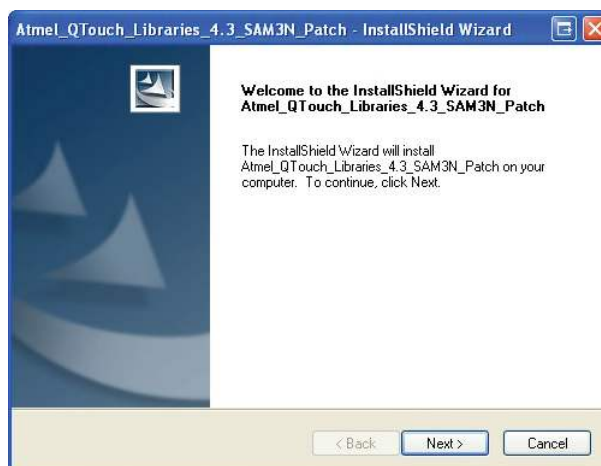
## 5.4 Getting Started

To use the QT600 interface, it is necessary to have QTouch Studio™ 3.4.0 or later installed. Download the latest version from [www.atmel.com](http://www.atmel.com).

Download and install the “Atmel\_QTouch\_Libraries\_4.3\_SAM3N\_Patch.exe” and follow the installation steps as detailed below:

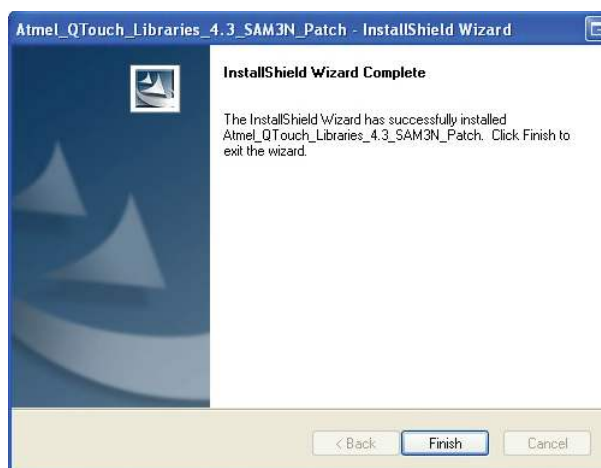
1. Start the installation process

**Figure 5-3.** Installation Step 1



2. Accept the terms of the licence agreement
3. Choose the destination location of the folder
4. Update the QT600 firmware
5. Install the program
6. When the installation is complete, click the “Finish” button

**Figure 5-4.** Installation Step 6



The SAM3N-EK boards must be programmed with the QTouch application code. For ARM products, the examples can be retrieved from the QTouch Library (installation process described on [page 5-3](#)).

The example projects must be compiled for the application to work. Refer to the *main.c* file in each project for details.

- For the SPI interface, the project files are located in:

C:\ProgramFiles\Atmel\Atmel\_QTouch\_Libraries\_4.3\Generic\_QTouch\_Libraries\AT91SAM\SAM3\QTouch\example\_projects\sam3n4\_iar\_qt\_example\_spi

- For the PIO interface, the project files are located in:

C:\ProgramFiles\Atmel\Atmel\_QTouch\_Libraries\_4.3\Generic\_QTouch\_Libraries\AT91SAM\SAM3\QTouch\example\_projects\sam3n4\_iar\_qt\_example

The Touch Data LED on the QT600 indicates the mode:

- Touch Data LED green: Touch Debug Mode (default mode after power-up).
- Touch Data LED off: Programmer Mode

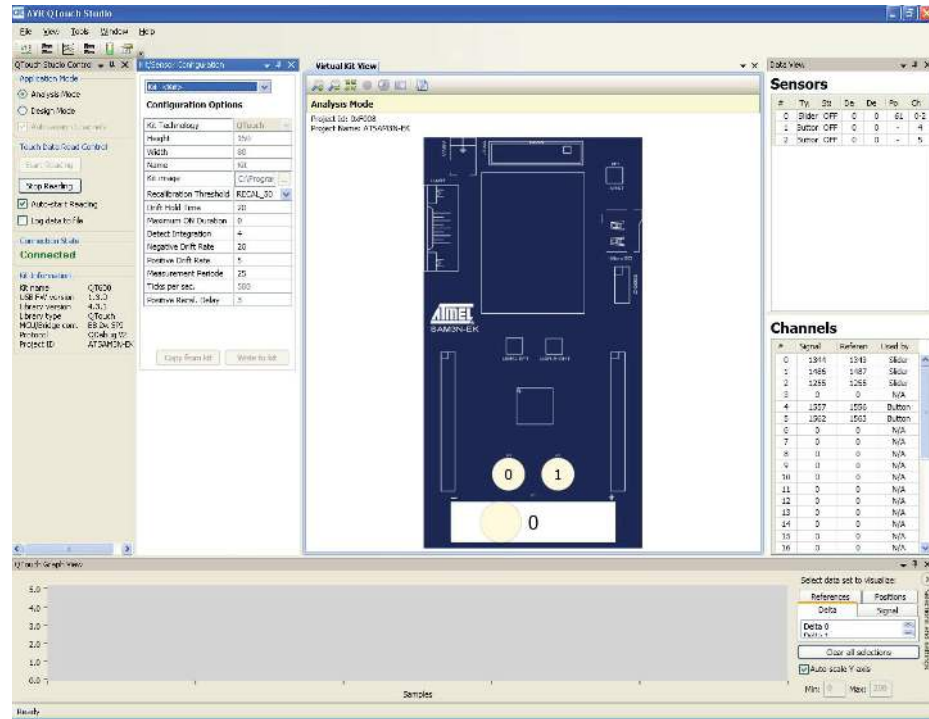
Make sure that the Touch Data LED is off before attempting to connect to the QT600 from the QTouch Studio programming dialog. Use AVR Studio 4.18 or later.

1. Connect the 10 wire flat-cable between the Touch Data header on the QT600 and the selected SAM3N-EK board (see [Figure 5-9 on page 5-7](#))
2. Make sure that VTG header is open on the QT600 (see [“Target Voltage VTG” on page 5-8](#))
3. Start AVR QTouch Studio
4. Plug in the USB cable to the QT600. AVR QTouch Studio should now automatically connect to the SAM3N-EK
5. Press the Start Debug button

You should now be able to view the touch data signals and the state of each sensor.



Figure 5-5. QTouch Studio GUI



## 5.5 Hardware Description

### 5.5.1 QT600 Interface Board

Figure 5-6. QT600 Interface Board

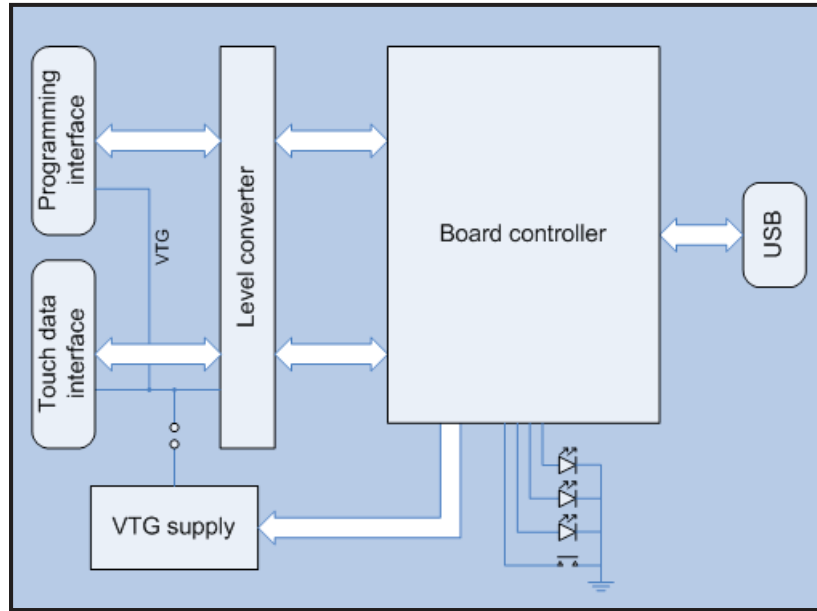


The QT600 Interface Board is the communication interface between the touch system (presently SAM3N-EK) and the AVR QTouch Studio. It receives touch signal data from the MCU running the QTouch Library, and forwards this data to the AVR QTouch Studio for visual presentation.

The QT600 can also be used as a programmer for programming the on-chip flash memory of the micro-controllers on the SAM3N-EK board.

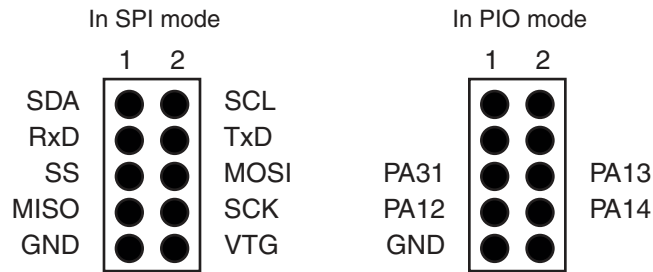


Figure 5-7. QT600 Interface Board Block Diagram



5.5.2 TOUCH DATA Connectors

Figure 5-8. TOUCH DATA Connector Pinout

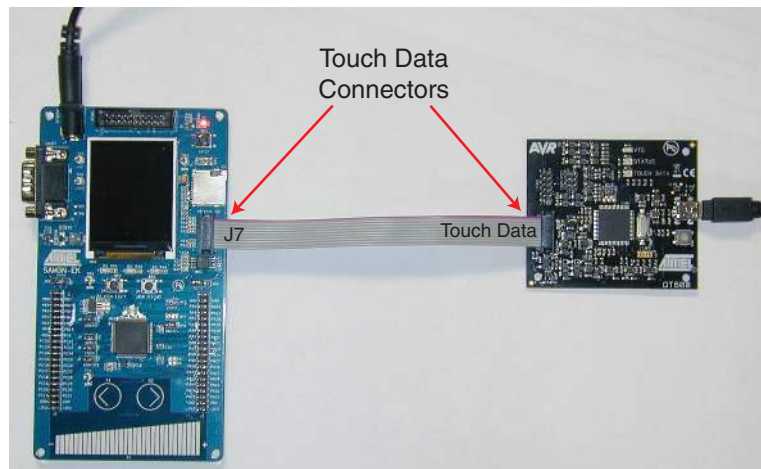


The TOUCH DATA connector located on the QT600 interface board is used for streaming touch data to the PC using the SPI (or PIO) interface. The corresponding connector is located on the Touch SAM3N-EK board. A straight 10-wire cable can be connected between these two connectors.

Table 5-1. TOUCH DATA Connector Pinout

Pin	Interface	Name	Direction, QT600 interface board	Direction SAM3N-EK	Remarks
1	TWI	SDA	Bi-directional	Bi-directional	Not used
2		SCL	Bi-directional	Bi-directional	
3	UART	RxD	Output	Input	Not used
4		TxD	Input	Output	
5	SPI	SS	Input	Output	
6		MOSI	Input	Output	
7		MISO	Output	Input	
8		SCK	Input	Output	
9	ALL	GND			
10	ALL	VTG			Keep Jumper Open

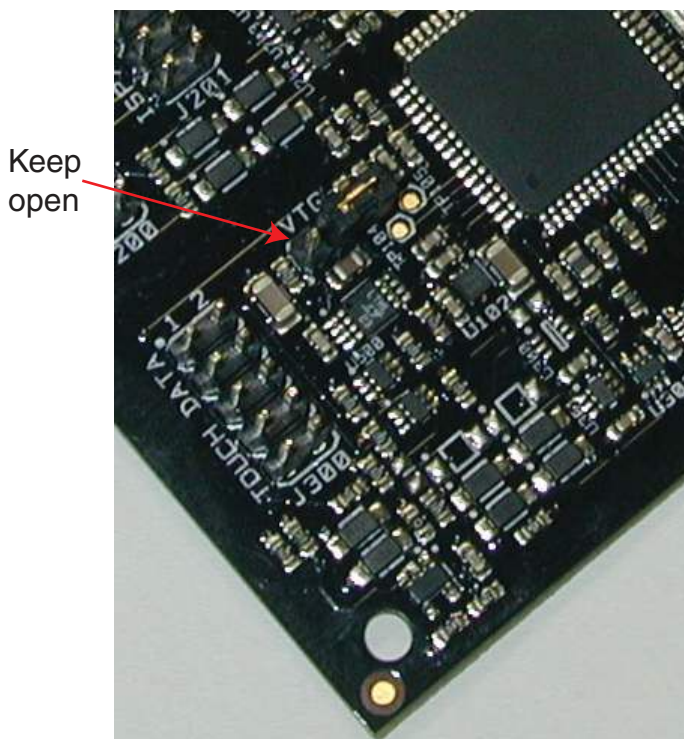
Figure 5-9. TOUCH DATA Connector



### 5.5.3 Target Voltage VTG

The VTG is supplied by the MCU board through the 10-wire cable (connected to the TOUCH DATA Connector).

**Figure 5-10.** VTG



### 5.5.4 VTG LED

A green LED labeled VTG on the QT600 board is lit when a voltage of 0.9V or higher is available on the VTG net.

### 5.5.5 TOUCH DATA LED

The status of the LED indicates the operating mode of the QT600.

#### 5.5.5.1 Touch Streaming Mode

When the QT600 is in Touch streaming mode (for use with AVR QTouch Studio), the TOUCH DATA LED is green. When touch data is received from the SAM3N-EK, the LED starts to flash.

#### 5.5.5.2 Programming Mode

When the QT600 is in programming mode (for use with AVR Qtouch Studio), the TOUCH DATA LED is not lit.

### 5.5.6 STATUS LED

- Green: Ready state
- Orange: Busy programming
- Orange/red flashing: Upgrade mode
- Orange/green flashing: Upgrade mode, upgrade in progress

During programming, the LED is orange. When the Atmel target device has been successfully programmed, the LED turns green.

### 5.5.7 Touch ATx Firmware

The firmware for the Touch ATx is based on the QTouch Library. The QTouch Library handles the touch acquisition. The touch measurement values are made available for the application firmware through an API, which is described in detail in the QTouch Library User Guide.

The touch measurement values available through the Touch Library API are sent to the QT600 with an SPI (or PIO) interface, using a custom protocol. AVR QTouch Studio will read these data packets from the QT600.

See the QT600 Protocol Document for details about the communication protocol.

---

## 5.6 Touch Debug

Before a touch debug session can be started, the target microcontroller on the SAM3N-EK board must be programmed. The example projects can be retrieved from the QTouch Library (installation steps are detailed in [Section 5.4](#)).

Example projects for both GCC and IAR compilers are available.

1. Connect a 10-wire cable between the Touch Data Connector on the SAM3N-EK board and the Touch Data connector on the QT600 Interface board (see [Figure 5-9 on page 5-7](#))
2. Start AVR QTouch Studio
3. Connect the USB cable to the QT600 interface board
4. Press the Start Debug Button in AVR QTouch Studio

AVR QTouch Studio automatically connects to the QT600 when the USB plug is inserted. The Touch Data streaming starts when the "Start Debug" button is pressed.

---

## 5.7 Using QT600 and AVR QTouch Studio for Custom Applications

The QT600 Interface Board and QTouch Studio can be used to read touch data from any application based on the QTouch Library. The only requirement is that there are two I/O pins available and that there is enough free space in flash for the debug protocol and serial interface driver.

The QT600 interface uses an SPI protocol at a frequency of 200 kHz.

Complete firmware driver files are available in the QT600 example projects, which can be downloaded from [www.atmel.com/QT600](http://www.atmel.com/QT600). See the readme.txt file in the QT600 Example Projects folder for instructions on how to add the QT600 protocol files to your firmware project.

## 5.8 Troubleshooting and Support

### 5.8.1 Technical Support

For technical support, contact [at91@atmel.com](mailto:at91@atmel.com). When requesting technical support for the QT600, you should provide the following information:

- PC processor type and speed
- PC operating system and version
- Atmel target device used (complete part number)
- Target voltage
- Jumper settings
- A detailed description of the problem

### 5.8.2 Force Firmware Upgrade

Before starting the procedure, make sure that the latest AVR Studio release (4.0 or later) has been installed on your PC.

1. If connected to the PC with a USB cable, unplug the QT600.
2. Press and hold the button on QT600 when connecting the USB cable: the status LED flashes red and orange, indicating the upgrade mode.
3. In AVR Studio, go to the Tools menu and select QT600 Upgrade.
4. The Atmel QT600 Upgrade program starts. If a connection has been established, the Status shows "QT600 present".
5. Press the Start Upgrade button: the upgrade program upgrades QT600's firmware.
6. When complete, a message box indicates if the upgrade was successful or not. Disconnect and then reconnect the USB cable.
7. If the upgrade was successful, the status LED turns green. Try to connect to the starter kit with QTouch Studio.

The QT600 USB Bridge firmware must be updated using the batch file available in "C:\...\QT600\_USB\_Bridge\_Update" folder before using the Example projects.

**Figure 5-11.** USB Connector





## Section 6

---

# Schematics

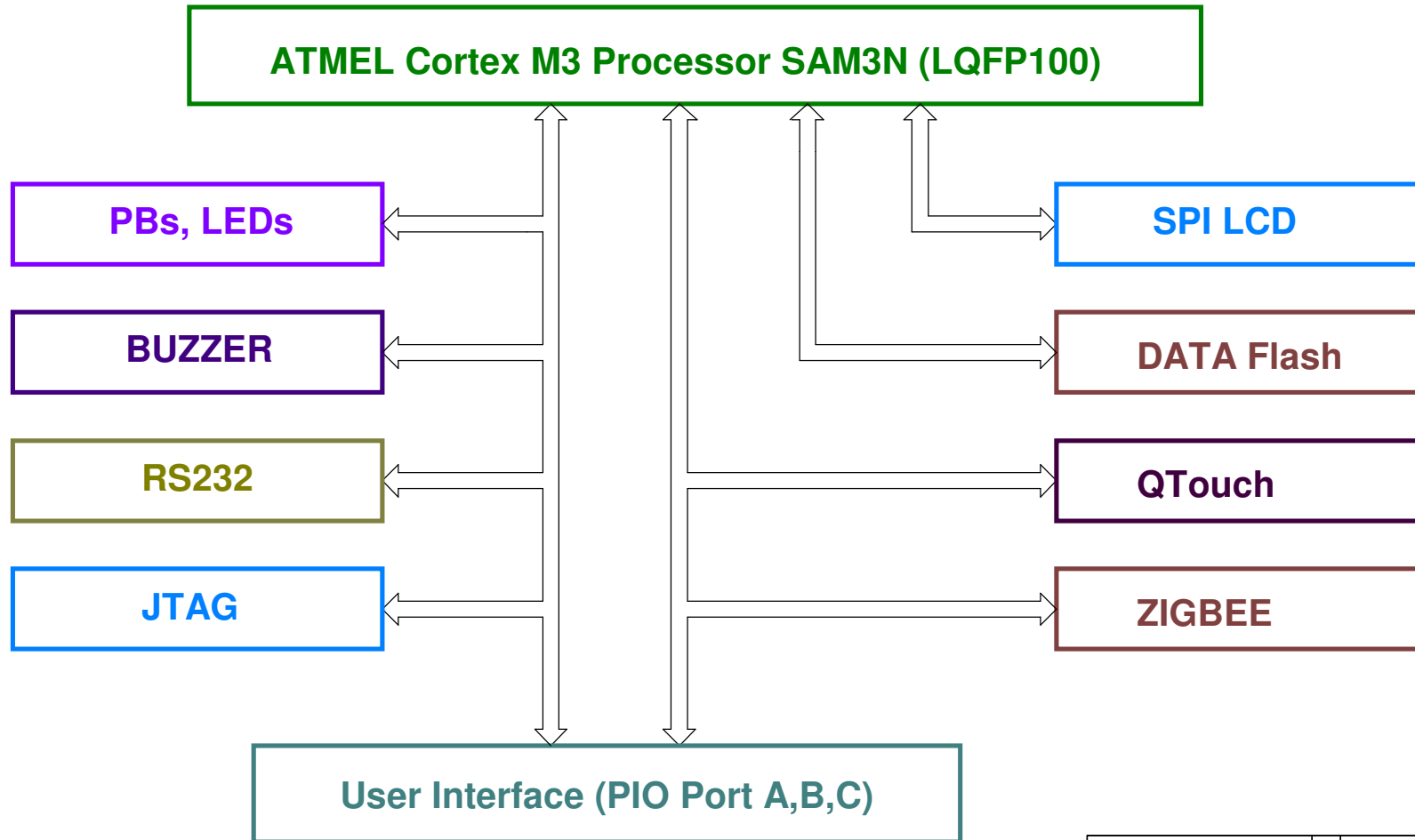
---

### 6.1 Schematics

This section contains the following schematics:

- Block Diagram
- Reference Guide
- Microcontroller, Power
- DataFlash, Micro SD, LCD, BL Driver, JTAG, RS232
- IO Expansion, Buzzer, ZigBEE, LEDs, Buttons, QTouch

# SAM3N-EK RevA Block Diagram



B		NL	05-MAY-10			
A	INIT EDIT	NL	05-MAR-10	XXX	XX-XXX-XX	
REV	MODIF.	DES.	DATE	VER.	DATE	
SAM3N-EK Block Diagram		SCALE	1/1	REV.	SHEET	
				<b>B</b>	1/5	

This agreement is our property. Reproduction and publication without our written authorization shall expose offender to legal proceedings.



## REVISION HISTORY

REV	DATA	NOTE
A	2010.03.04	ORIGINAL RELEASED

## SCHEMATICS CONVENTIONS

(1) Resistance Unit: "K" is "Kohm", "R" is "Ohm"?
(2) "DNP" means the component is not populated by default

## JUMPER and SOLDERDROP

PAGE	REFERENCE	DEFAULT	FUNCTION
3	JP1	DNP	Close to select JTAG boundary scan
	JP2	1-2	Analog reference voltage selection between 3.3V and 3V, default 3.3V
	JP3	OPEN	ERASE, Close to reinitialize the Flash contents and some of its NVM bits
	JP4	CLOSE	Access for current measurement on VDDIO
	JP5	CLOSE	Access for current measurement on VDDIN
	JP6	CLOSE	Access for current measurement on VDDPLL
	JP7	CLOSE	Access for current measurement on VDDCORE
5	JP8 JP9	1-2	DC voltage selection between 3.3V and 5V on PIO expansion ports, default for 3.3V

## TABLE OF CONTENTS

PAGE	DESCRIPTION
1	Block Diagram
2	Reference guide
3	Microcontroller, Power
4	Data Flash, Micro SD, LCD, BL Driver, JTAG, RS232
5	IO Expansion, Buzzer, ZigBEE, LEDs, Buttons, QTouch

## TEST POINT

PAGE	REFERENCE	FUNCTION
3	TP1	+5V
	TP2	+3V3
	TP3, TP4, TP5	GND
4	TP6 TP7	UTXD0 URXD0

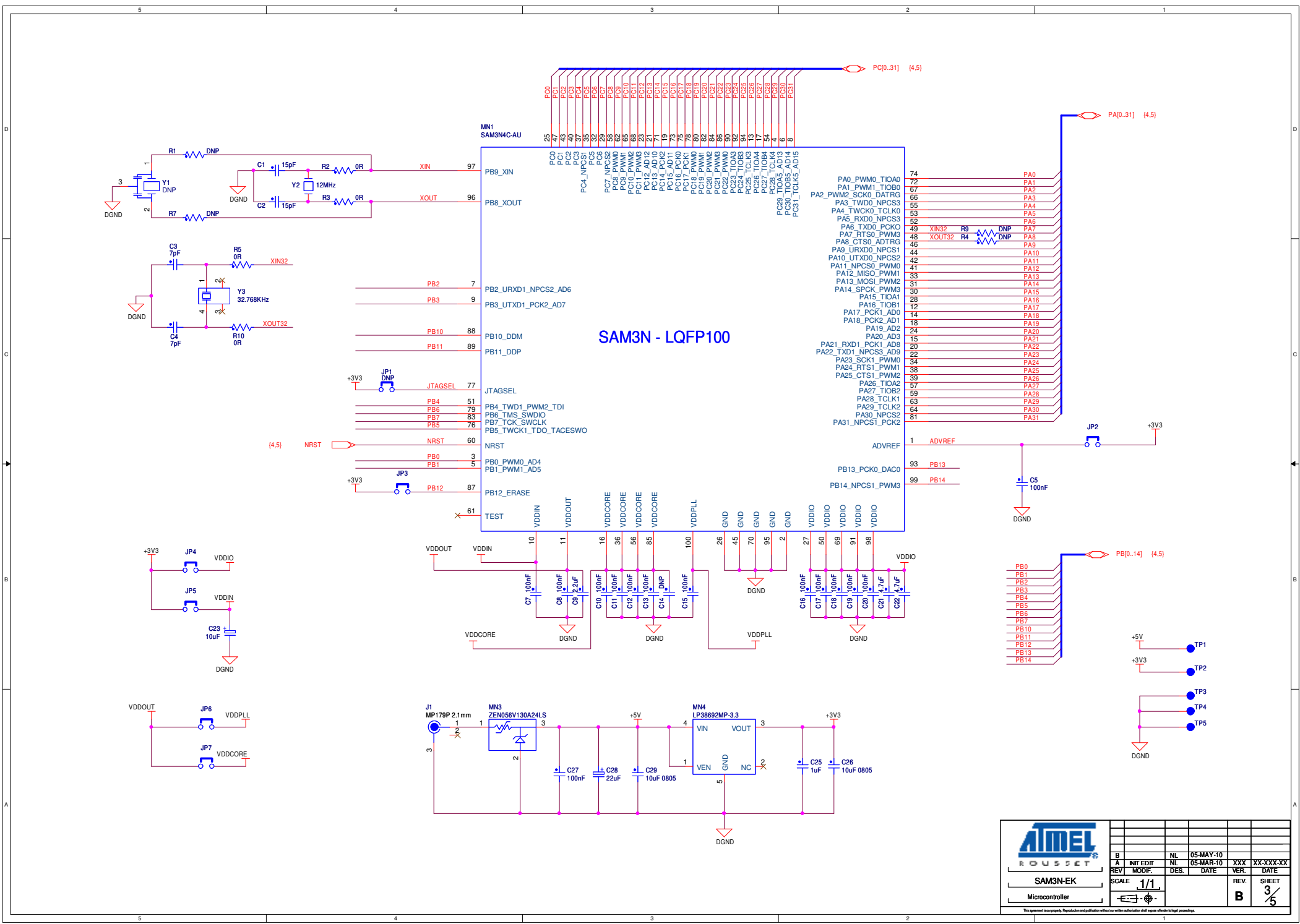
## PIO MUXING

PIOA	USAGE	PIOA	USAGE	PIOB	USAGE	PIOC	USAGE	PIOC	USAGE
PA0	POWER LED	PA16	PB_USER2	PB0		PC0	QT_SL_SNS	PC16	
PA1	CMD_SOUND	PA17		PB1		PC1	QT_SL_SNSK	PC17	
PA2		PA18		PB2		PC2	QT_SM_SNS	PC18	
PA3		PA19	MicroSD_CD	PB3		PC3	QT_SM_SNSK	PC19	
PA4		PA20		PB4	JTAG	PC4	QT_SR_SNS	PC20	
PA5		PA21		PB5	JTAG	PC5	QT_SR_SNSK	PC21	
PA6		PA22	NPCS_DATAFLASH	PB6	JTAG	PC6		PC22	
PA7	XIN32	PA23	LED_BLUE	PB7	JTAG	PC7		PC23	ZB_RSTN
PA8	XOUT32 / ADTRG	PA24		PB8	XOUT_12M	PC8	QT1_SNS	PC24	ZB_IRQ0
PA9	RX_UART0	PA25	LED_AMBER	PB9	XIN_12M	PC9	QT1_SNSK	PC25	ZB_IRQ1
PA10	TX_UART0	PA26		PB10		PC10	QT2_SNS	PC26	ZB_SLPTR
PA11		PA27		PB11		PC11	QT2_SNSK	PC27	
PA12	SPI_MISO	PA28	RS_LCD	PB12	ERASE	PC12		PC28	
PA13	SPI_MOSI	PA29	RST_LCD	PB13		PC13	EN_LCD	PC29	
PA14	SPI_SPCK	PA30	NPCS_LCD	PB14	LED_GREEN	PC14		PC30	
PA15	PB_USER1	PA31	NPCS_ZigBee			PC15		PC31	

## DEFAULT NO POPULATE PARTS

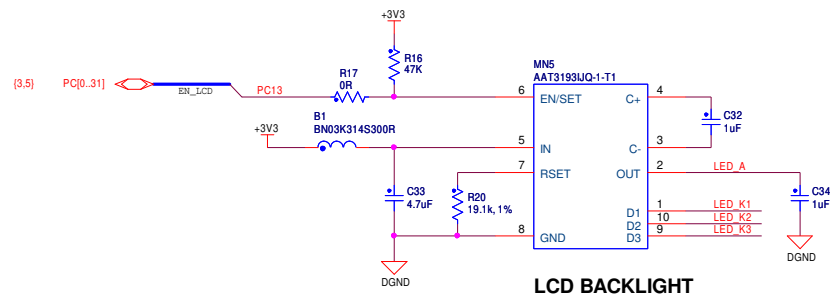
PAGE	REFERENCE	FUNCTION
3	Y1, R1, R7	External clock resource input
	JP1	Option access for JTAGSEL
	R6, R8 R4, R9	Isolation between 12MHz clock source and GPIO line Isolation between 32KHz clock source and GPIO line
5	S1, K1, K2	QTouch PADS, not real part

B	INT EDIT	NL	05-MAY-10		
A	REV	NL	05-MAR-10	XXX	XX-XXX-XX
	MODIF.	DES.	DATE	VER.	DATE
SAM3N-EK		SCALE	1/1	REV.	SHEET
Describe				B	2/5
<small>This document is our property. Reproduction and publication without our written authorization shall expose violator to legal proceedings.</small>					

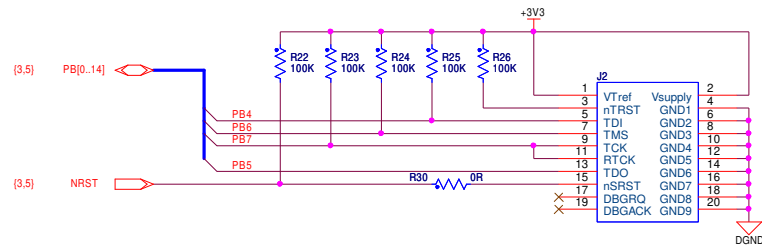


<b>ATMEL</b> ROUSSET					
B	INIT EDIT	NL	05-MAY-10	XXX	XX-XXX-XX
A	MODIF.	NL	05-MAR-10	VER.	DATE
SCALE	1/1			REV.	SHEET
Microcontroller				B	3/5

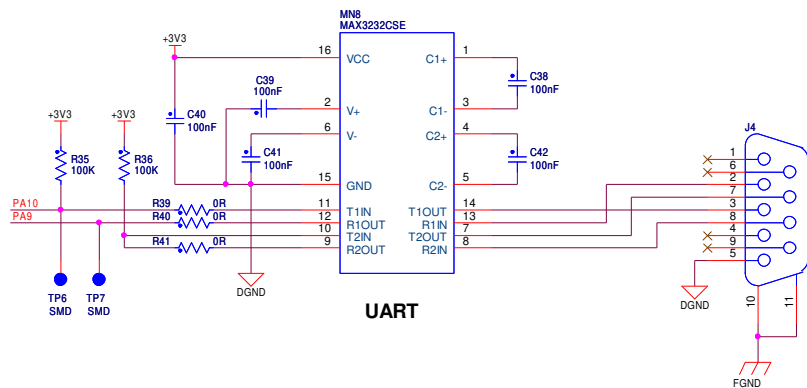
This document is property of ATMEL. Reproduction and publication without written authorization shall remain under legal proceedings.



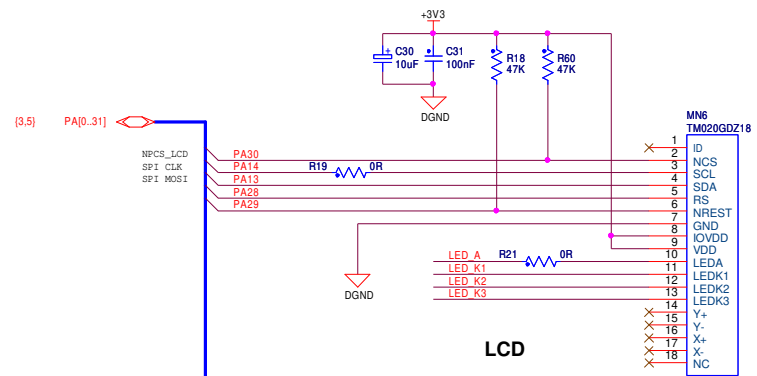
LCD BACKLIGHT



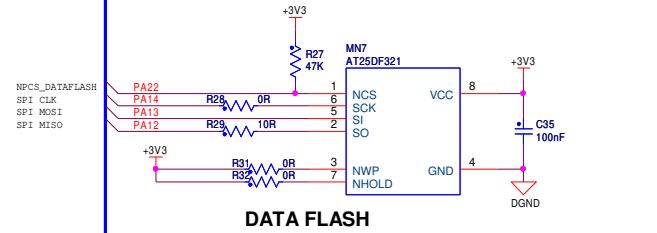
ICE INTERFACE



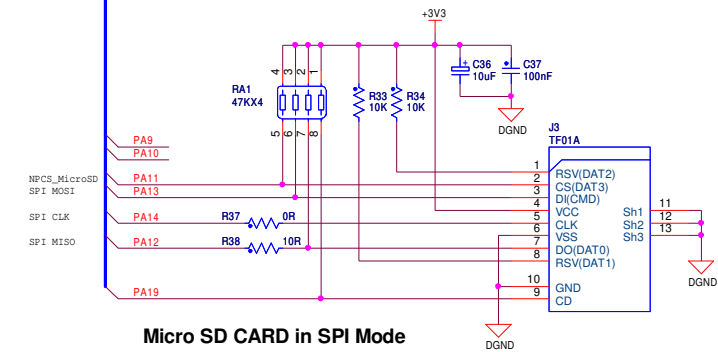
UART



LCD



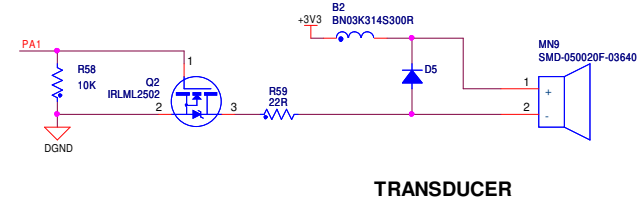
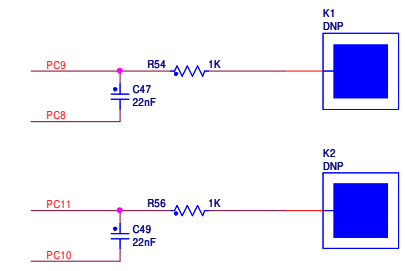
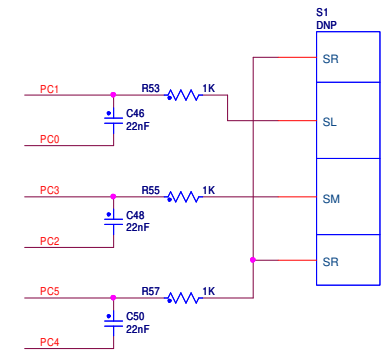
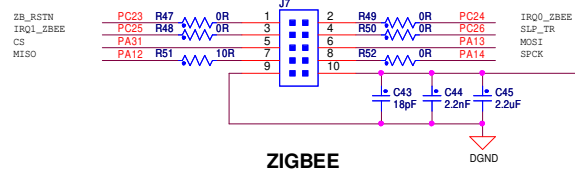
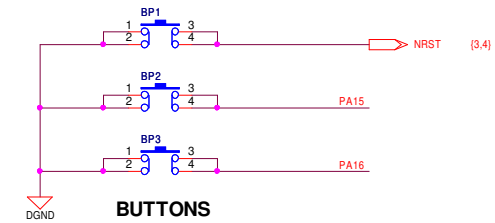
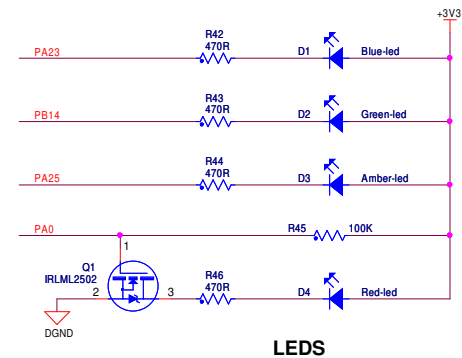
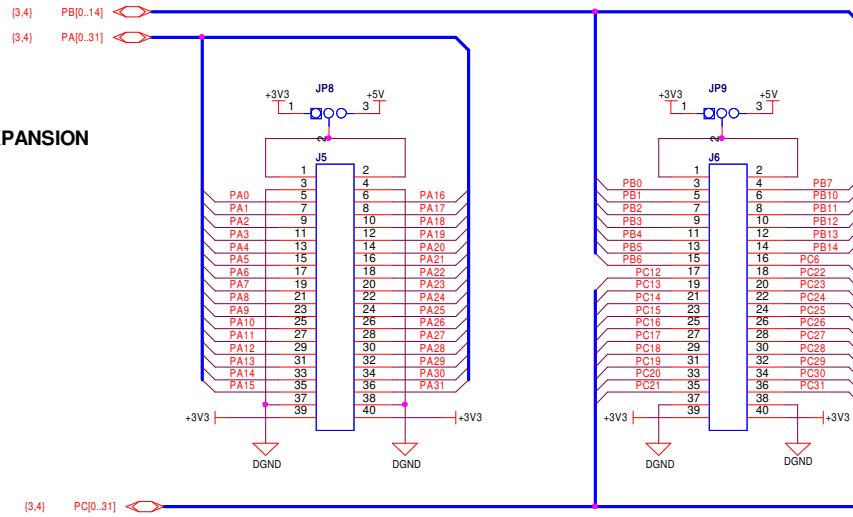
DATA FLASH



Micro SD CARD in SPI Mode

A	INT EDIT	NL	05-MAY-10	XXX	XX-XXX-XX
REV	MODIF.	DES.	DATE	VER.	DATE
SAM3N-EK		SCALE	1/1	REV.	SHEET
Peripheral_1				B	4/5
<small>                 This document is our property. Reproduction and publication without our written authorization shall remain strictly prohibited.             </small>					

### PIO EXPANSION



<b>ATMEL</b> ROUSSET		REV.	DATE	VER.	DATE
B	INT EDIT	NL	05-MAY-10	XXX	XX-XXX-XX
A	MODIF.	DES.	05-MAR-10	DATE	DATE
SAM3N-EK		SCALE	1/1	REV.	SHEET
Peripheral_2				B	5/5
<small>Management de propriété. Reproduction et publication without written authorization and respect of the legal proceedings.</small>					



## Section 7

---

# Troubleshooting

---

### 7.1 Self-Test

A test package software is available to implement a functional test for each section of the board. Refer to the SAM3N-EK page on [http://www.atmel.com/dyn/products/tools\\_card.asp?tool\\_id=4846](http://www.atmel.com/dyn/products/tools_card.asp?tool_id=4846).

### 7.2 Board Recovery

The CDROM provided in the kit contains a recovery procedure allowing to reprogram the board as it was when shipped. An HTML page describing that procedure is located in the directory html of the CDROM. Just open the file demo\_recovery.html you will find in there.



## Section 8

# Revision History

### 8.1 Revision History

*Table 8-1.*

Document	Comments	Change Request Ref.
11080C	Note 2 added to <a href="#">Section 4.3.9 "JTAG/ICE"</a> .	7636
11080B	<a href="#">Section 5 "QT600"</a> added.	7544
11080A	First issue.	



## Headquarters

### **Atmel Corporation**

2325 Orchard Parkway  
San Jose, CA 95131  
USA  
Tel: (+1) (408) 441-0311  
Fax: (+1) (408) 487-2600

## International

### **Atmel Asia Limited**

Unit 01-5 & 16, 19F  
BEA Tower, Millennium City 5  
418 Kwun Tong Road  
Kwun Tong, Kowloon  
HONG KONG  
Tel: (+852) 2245-6100  
Fax: (+852) 2722-1369

### **Atmel Munich GmbH**

Business Campus  
Parking 4  
D-85748 Garching b. Munich  
GERMANY  
Tel: (+49) 89-31970-0  
Fax: (+49) 89-3194621

### **Atmel Japan**

9F, Tonetsu Shinkawa Bldg.  
1-24-8 Shinkawa  
Chuo-ku, Tokyo 104-0033  
JAPAN  
Tel: (81) 3-3523-3551  
Fax: (81) 3-3523-7581

## Product Contact

### **Web Site**

[www.atmel.com](http://www.atmel.com)  
[www.atmel.com/AT91SAM](http://www.atmel.com/AT91SAM)

### **Technical Support**

AT91SAM Support  
Atmel technical support

### **Sales Contacts**

[www.atmel.com/contacts/](http://www.atmel.com/contacts/)

### **Literature Requests**

[www.atmel.com/literature](http://www.atmel.com/literature)

**Disclaimer:** The information in this document is provided in connection with Atmel products. No license, express or implied, by estoppel or otherwise, to any intellectual property right is granted by this document or in connection with the sale of Atmel products. **EXCEPT AS SET FORTH IN ATMEL'S TERMS AND CONDITIONS OF SALE LOCATED ON ATMEL'S WEB SITE, ATMEL ASSUMES NO LIABILITY WHATSOEVER AND DISCLAIMS ANY EXPRESS, IMPLIED OR STATUTORY WARRANTY RELATING TO ITS PRODUCTS INCLUDING, BUT NOT LIMITED TO, THE IMPLIED WARRANTY OF MERCHANTABILITY, FITNESS FOR A PARTICULAR PURPOSE, OR NON-INFRINGEMENT. IN NO EVENT SHALL ATMEL BE LIABLE FOR ANY DIRECT, INDIRECT, CONSEQUENTIAL, PUNITIVE, SPECIAL OR INCIDENTAL DAMAGES (INCLUDING, WITHOUT LIMITATION, DAMAGES FOR LOSS OF PROFITS, BUSINESS INTERRUPTION, OR LOSS OF INFORMATION) ARISING OUT OF THE USE OR INABILITY TO USE THIS DOCUMENT, EVEN IF ATMEL HAS BEEN ADVISED OF THE POSSIBILITY OF SUCH DAMAGES.** Atmel makes no representations or warranties with respect to the accuracy or completeness of the contents of this document and reserves the right to make changes to specifications and product descriptions at any time without notice. Atmel does not make any commitment to update the information contained herein. Unless specifically provided otherwise, Atmel products are not suitable for, and shall not be used in, automotive applications. Atmel's products are not intended, authorized, or warranted for use as components in applications intended to support or sustain life.



© 2011 Atmel Corporation. All rights reserved. Atmel®, logo and combinations thereof DataFlash®, SAM-BA® and others are registered trademarks or trademarks of Atmel Corporation or its subsidiaries. ARM®, Thumb® and the ARMPowered logo® and others are registered trademarks or trademarks ARM Ltd. Windows® and others are registered trademarks or trademarks of Microsoft Corporation in the US and/or other countries. Other terms and product names may be trademarks of others.