

Model 830, 860



Vishay Spectrol

1 - 13/16" (46mm) Three and Ten Turn Wirewound Precision Potentiometer



FEATURES

- 830: 15Ω to 50KΩ, Three-Turn
- 860: 20Ω to 200KΩ, Ten-Turn

ELECTRICAL SPECIFICATIONS

PARAMETER	MODEL 830	MODEL 860
Total Resistance Standard Range	15Ω to 50KΩ Special to 150KΩ	20Ω to 200KΩ Special to 500KΩ
Tolerance: 200Ω and above Below 200Ω	STANDARD ± 3% ± 5%	SPECIAL ± 1% ± 3%
Linearity (Independent)	± 0.25% standard	
15Ω to 1KΩ	± 0.15%	—
1KΩ to 5KΩ	± 0.10%	—
5KΩ to 25KΩ	± 0.075%	—
25KΩ and above	± 0.05%	—
20Ω to 50Ω	—	± 0.15%
50Ω to 200Ω	—	± 0.10%
200Ω to 5KΩ	—	± 0.05%
5KΩ and above	—	± 0.025%
Noise	100Ω ENR for both models	
Rotation	1080° + 4° - 0°	3600° + 4° - 0°
Power Rating	3.0 watts at 40°C derated to zero at 125°C	8.0 watts at 40°C derated to zero at 125°C
Insulation Resistance	1000MΩ minimum 500VDC	
Dielectric Strength	1000V _{RMS} , 60Hz	
Absolute Minimum Resistance	Not to exceed linearity x total resistance or 1Ω, whichever is greater	
End Voltage	0.5% of total applied voltage maximum	
Phasing	CCW End Points sect. 2 phased to sect 1 within 1°	
Taps (Extra)	42 available as special standard tolerance ± 1°	108 available as special standard tolerance ± 1°

ORDERING INFORMATION

Models 830 and 860 can be ordered from this data sheet with a variety of alternate characteristics, as shown. For most rapid service on your order, please state:

830, 860	1	1	XXX
MODEL	BUSHING MOUNT	NUMBER OF SECTIONS	RESISTANCE OF EACH SECTION
			Beginning with the section nearest the mounting end

Other characteristics will be standard as described on this data sheet. If special characteristics are required, such as: special linearity tolerance, special resistance tolerance, extra taps, non-linear functions, etc., please state these on your order and allow additional lead time for delivery.



DIMENSIONS in inches (millimeters)

MODEL 830

MODEL 860

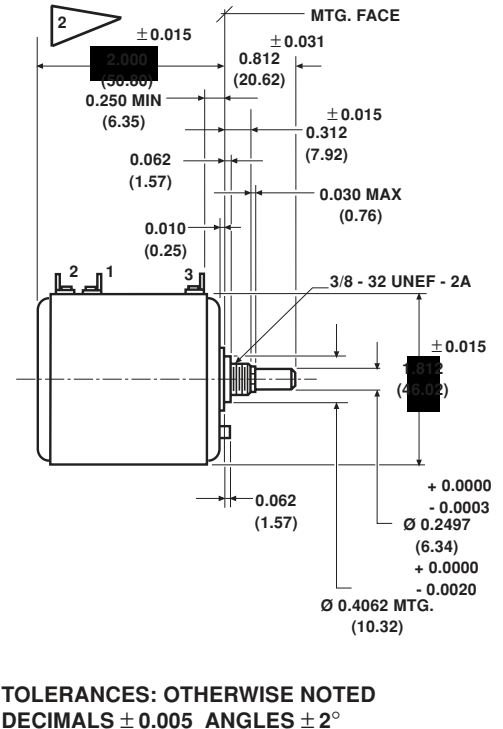
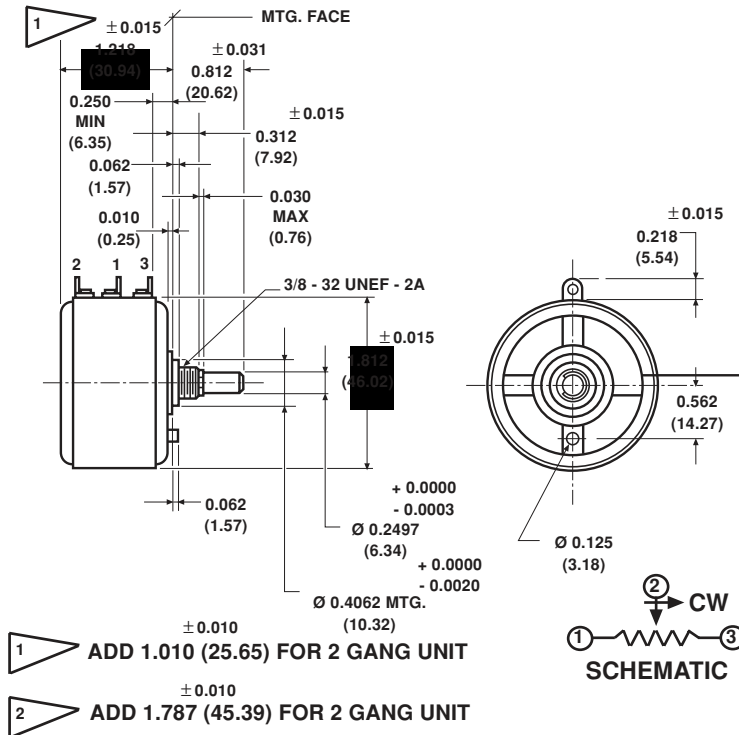

**TOLERANCES: OTHERWISE NOTED
 DECIMALS ± 0.005 ANGLES $\pm 2^\circ$**

MECHANICAL SPECIFICATIONS		
PARAMETER	830	860
Rotation	1080° + 4° - 0°	3600° + 4° - 0°
Bearing Type	Sleeve Bearing	
Torque (maximums): Starting	STARTING	RUNNING
Section 1	1.75 oz - in (126.02gm - cm)	1.26 oz - in (90.01gm - cm)
Section 2	2.55 oz - in (183.62gm - cm)	1.85 oz - in (133.21gm - cm)
Runouts (Maximums)		
Shaft (TIR)	0.002 in (0.05cm)	
Pilot Dia (TIR)	0.002 in (0.05cm)	
Lateral (TIR)	0.005 in (0.13cm)	
Shaft End Play	0.002 in min 0.010 in Maximum (0.05 - 0.25cm)	
Shaft Radial Play	0.003 in Maximum (0.08cm)	
Weight (maximums)		
Single Section	3.0 oz (85.05gm)	4.5 oz (127.58gm)
Additional Section	2.5 oz (70.80gm)	4.0 oz (113.40gm)
Stop Strength	750 oz - in (static) (54.01Kg - cm)	
Ganging	2 sections maximum ears of clamp band between sections positioned 45°, $\pm 10^\circ$ CCW from terminal center line	
Moment Inertia	5.5gm - cm ² Maximum	15.0gm - cm ² Maximum

Model 830, 860



Vishay Spectrol 1 - 13/16" (46mm) Three and Ten Turn Wirewound Precision Potentiometer

MATERIAL SPECIFICATIONS	
Bushing	Aluminum, nickel plated
Housing and Front Lid	Molded glass filled thermoset plastic
Rear Lid	Molded glass filled nylon
Shaft	Stainless steel, non magnetic, non-passivated
Terminals	Brass, plated for solderability
Mounting Hardware Lock washer: Panel nut:	Internal tooth Steel, nickel plated Brass, nickel plated

MARKING	
Unit Identification	Units will be marked with Spectrol name and model no, resistance and resistance tolerance, linearity, terminal identification, and date code

ENVIRONMENTAL SPECIFICATIONS	
Vibration	10g thru 500 CPS
Shock	50g
Rotational Life	500,000 shaft revolution
Load Life	900 Hours
Temperature Range	- 55°C to + 125°C
Moisture Resistant	-
Salt Spray	48 hours

POWER RATING CHART

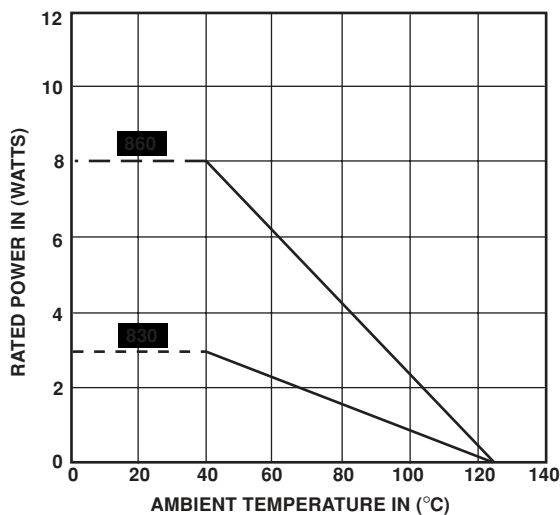

RESISTANCE ELEMENT DATA					
STANDARD RESISTANCE VALUES (Ω)	RESOLUTION (%)	OHMS PER TURN	MAXIMUM CURRENT AT 70°C AMBIENT (mA)	MAXIMUM VOLTAGE ACROSS COIL (V)	WIRE TEMP. COEF. (ppm/°C)
MODEL 860					
20	0.044	0.009	632	13	800
50	0.027	0.014	400	20	800
100	0.024	0.024	283	28	800
200	0.028	0.056	200	40	180
500	0.023	0.115	126	63	20
1K	0.018	0.182	89	89	20
2K	0.020	0.402	63	126	110
5K	0.015	0.754	40	200	20
10K	0.013	1.23	28	283	20
20K	0.010	1.97	20	400	20
50K	0.007	3.69	13	632	20
100K	0.007	6.51	8.9	894	20
200K	0.005	9.63	5.0	1,000	20
500K	0.004	20.0	2.0	1,000	20
MODEL 830					
20	0.094	0.019	387	8	800
50	0.074	0.037	245	12	800
100	0.071	0.071	173	17	180
200	0.072	0.145	122	25	20
500	0.064	0.320	77	39	110
1K	0.050	0.500	55	55	110
2K	0.047	0.948	39	77	20
5K	0.035	1.73	24	125	20
10K	0.029	2.92	17	176	20
20K	0.024	4.80	12	250	20
50K	0.017	8.31	8	375	20
100K	0.015	14.5	5	600	20
150K	0.013	20.0	4	750	20



Notice

Specifications of the products displayed herein are subject to change without notice. Vishay Intertechnology, Inc., or anyone on its behalf, assumes no responsibility or liability for any errors or inaccuracies.

Information contained herein is intended to provide a product description only. No license, express or implied, by estoppel or otherwise, to any intellectual property rights is granted by this document. Except as provided in Vishay's terms and conditions of sale for such products, Vishay assumes no liability whatsoever, and disclaims any express or implied warranty, relating to sale and/or use of Vishay products including liability or warranties relating to fitness for a particular purpose, merchantability, or infringement of any patent, copyright, or other intellectual property right.

The products shown herein are not designed for use in medical, life-saving, or life-sustaining applications. Customers using or selling these products for use in such applications do so at their own risk and agree to fully indemnify Vishay for any damages resulting from such improper use or sale.