

MATERIAL NUMBER	FINISH
43178-4001	999
43178-4002	H901

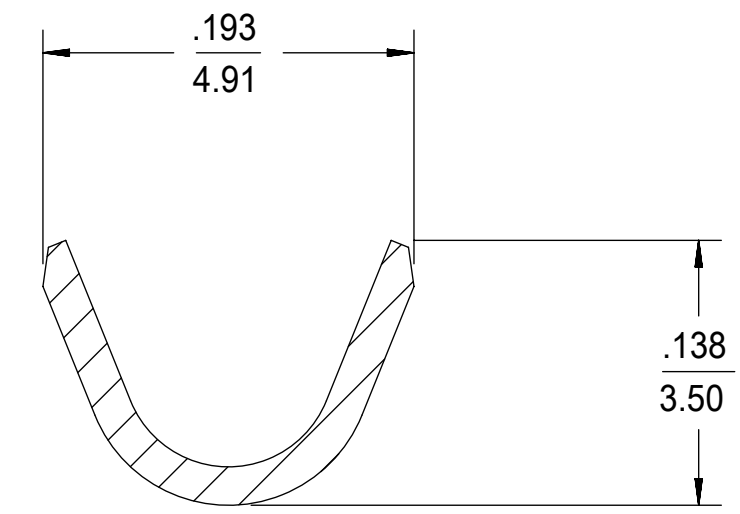

SECTION W-W
SCALE 10:1
CONDUCTOR CRIMP

SECTION V-V
SCALE 10:1
INSULATION CRIMP

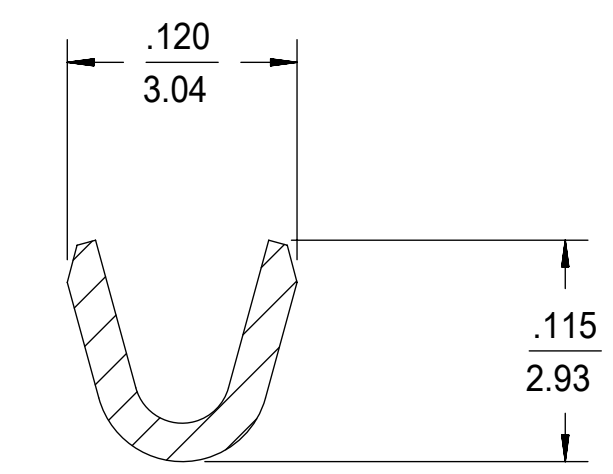
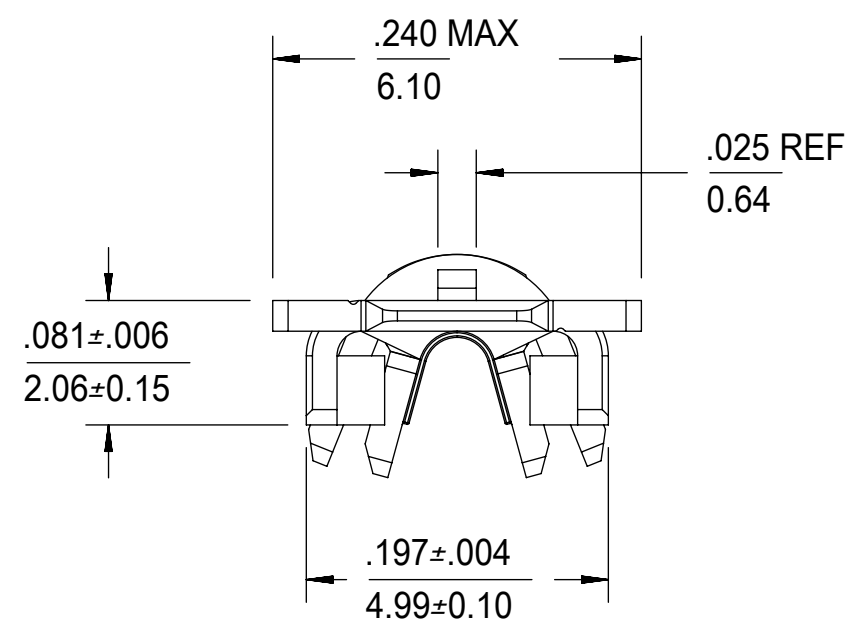
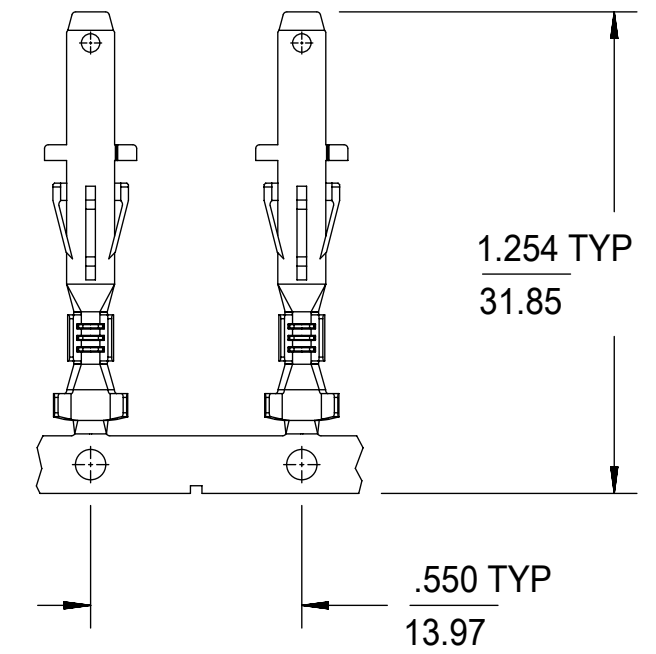

CARRIER STRIP PROGRESSION
SCALE 2:1

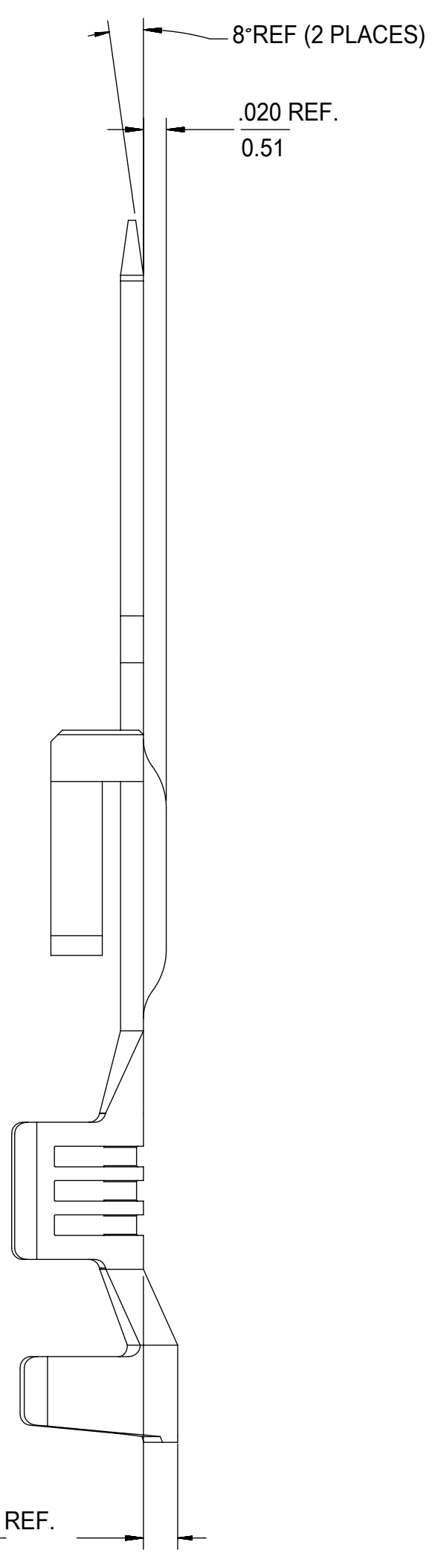
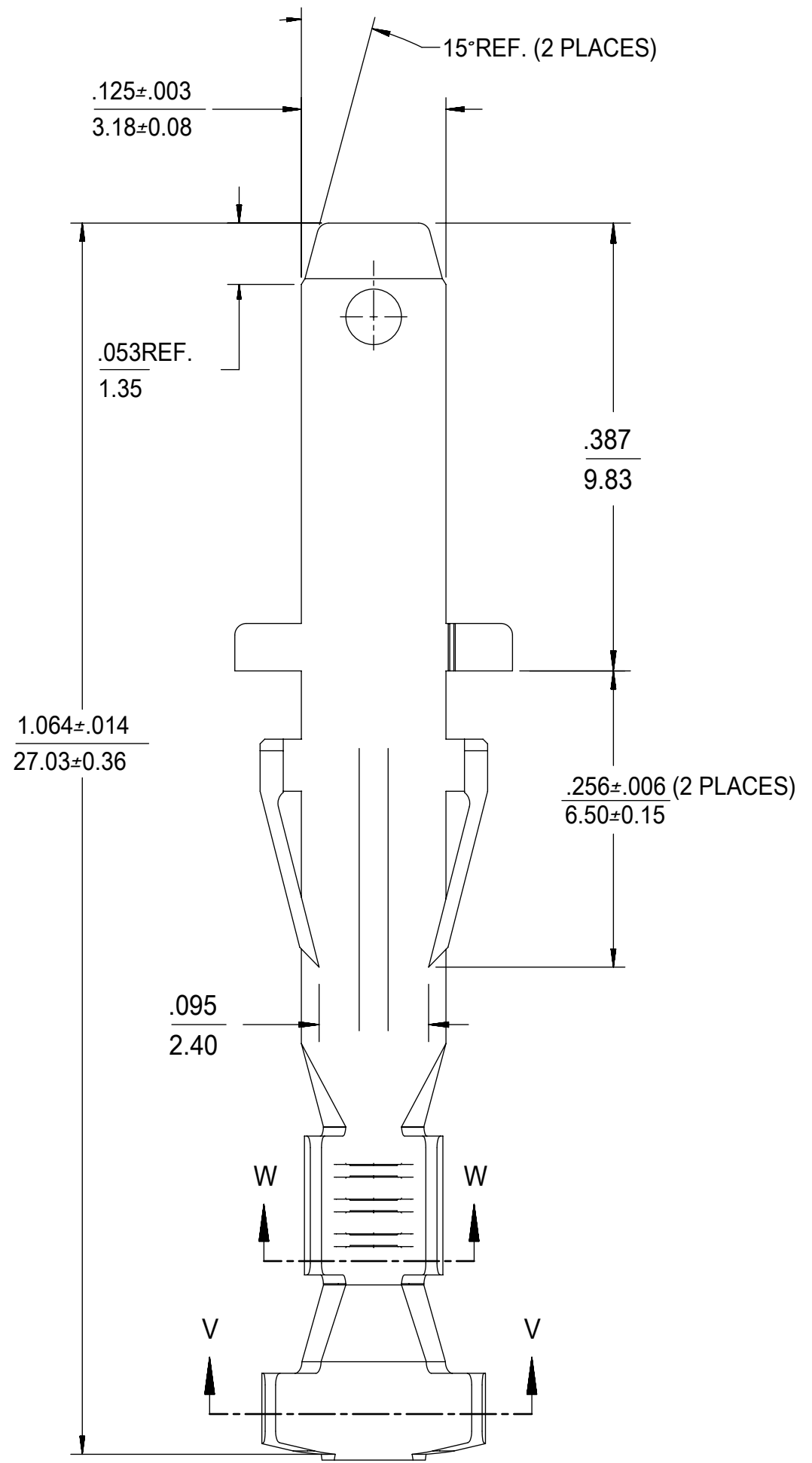

NOTES:

- MATERIAL: BRASS
- FINISH:
999 - UNPLATED
H901 - 20 MICROINCH / 0.5 MICROMETERE MIN. PREPLATED HOT TIN DIP
- PRODUCT SPECIFICATION: PS-44441-9999
- PACKAGING: TERMINALS ARE WOUND ON 30" REELS WITH PAPER INTERLEAF. 6000 PER REEL. ACCORDING TO 431780000-PK
- TERMINAL ACCEPTS SINGLE #18 OR #20 AWG STRANDED WIRE; INSULATION: UL TYPE 1015, .098-.110 / 2.50-2.85 DIAMETER, (.031 / 0.79 NOMINAL JACKET WALL THICKNESS) OR DOUBLE 22 AWG.
- TERMINAL FOR USE IN "SABRE" PLUG HOUSINGS, SERIES 43680. MATES TO 43374 / 43375 SERIES TERMINALS.
- TERMINAL HAS TPA (TOTAL POSITIONING ASSURANCE) OPTIONAL ACTIVATION FEATURE THAT WHEN ACTIVATED AND USED WITH MOLEX "SABRE" SERIES PLUG HOUSINGS PROVIDES A SECONDARY LOCK SYSTEM WHICH ENSURES AGAINST TERMINAL BACKOUTS.
- PARTS CONFORM TO CLASS 'B' REQUIREMENTS OF COSMETIC SPECIFICATION PS-45499-002.

THIS DRAWING CONTAINS INFORMATION THAT IS PROPRIETARY TO MOLEX ELECTRONIC TECHNOLOGIES, LLC AND SHOULD NOT BE USED WITHOUT WRITTEN PERMISSION									
SYMBOLS		DIMENSION UNITS		SCALE		CURRENT REV DESC: ADD PK SPEC			
▽ = 0	IN/MM	8:1		EC NO: 617584 DRWN: JEHRISMAN 2019/04/02 CHK'D: MKIPPER 2019/06/13 APPR: FSMITH 2019/06/18 INITIAL REVISION: DRWN: CSTEWARD 2006/02/23 APPR: BWIRKUS 2006/02/23					
▽ = 0	GENERAL TOLERANCES (UNLESS SPECIFIED)								
▽ = 0	MM	INCH							
▽ = 0	4 PLACES	±	±						
▽ = 0	3 PLACES	±	± 0.01						
▽ = 0	2 PLACES	± 0.25	± 0.014						
▽ = 0	1 PLACE	± 0.35	±						
▽ = 0	0 PLACES	±	±						
▽ = 0	ANGULAR TOL	± 0.5 °							
▽ = 0	DRAFT WHERE APPLICABLE MUST REMAIN WITHIN DIMENSIONS		THIRD ANGLE PROJECTION		DRAWING		SERIES		
▽ = 0			C-SIZE		43178		MATERIAL NUMBER		
								CUSTOMER	
								SHEET NUMBER	
								1 OF 1	

molex

TERMINAL, MALE CRIMP,
18-20 AWG, .125 WIDE TAB SABRE SERIES, W/ TPA

PRODUCT CUSTOMER DRAWING

DOCUMENT NUMBER	DOC TYPE	DOC PART	REVISION
SD-43178-002	PSD	001	A2

DOCUMENT STATUS	P1	RELEASE DATE	2019/06/18 16:00:30
-----------------	----	--------------	---------------------