

REVISIONS				
P	LTR	DESCRIPTION	DATE	APP'D
B		REVISED PER ECO-15-015252	13NOV15	BJ FY

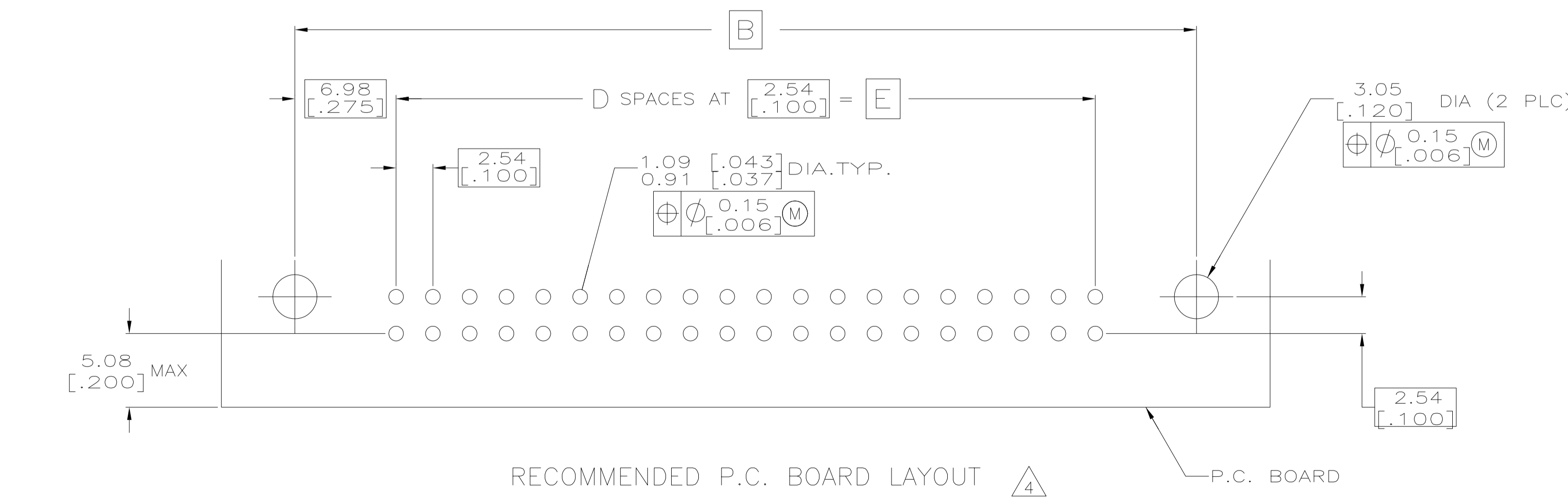

- 1 HOUSING MATERIAL: THERMOPLASTIC.
- 2 CONTACT MATERIAL: COPPER ALLOY.
- 3 FINISH:
MATING AREA: MEETS THE PERFORMANCE REQUIREMENTS OF PRODUCT SPECIFICATION 108-9063; BASED ON TELCORDIA DR-1217-CORE APPLICATIONS IN UNCONTROLLED ENVIRONMENTS.
TIN PLATED POSTS.
- 4 SOLDER TAILS MUST FIT HOLE PATTERN AS SHOWN ON THE RECOMMENDED P.C. BOARD LAYOUT.
- 5. DIMENSIONS IN BRACKETS ARE IN INCHES.
- 6 HOUSINGS WITH CENTER MOUNTING IS RECOMMENDED FOR ASSEMBLIES HAVING 75 CONTACTS PER ROW OR MORE.
- 7 QUANTITIES OF VOID CORING ARE DEPENDENT ON THE POSITION SIZE OF THE HOUSING.
- 8 OBSOLETE PARTS: OBSOLETE CIS STREAMLINING PER D.RENAUD/D.SINISI

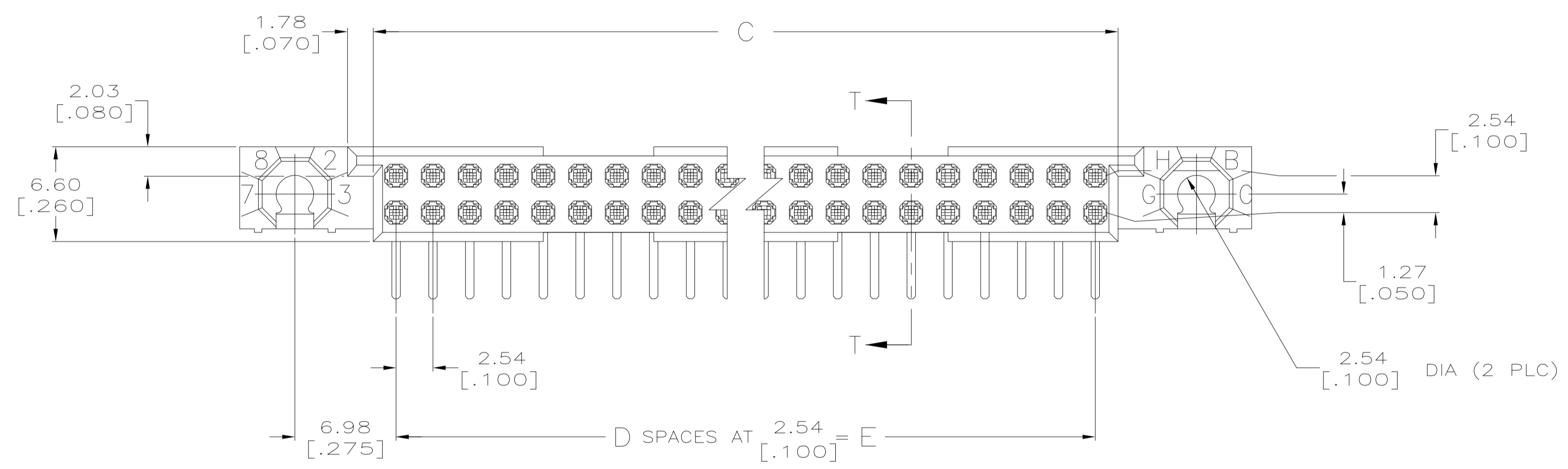
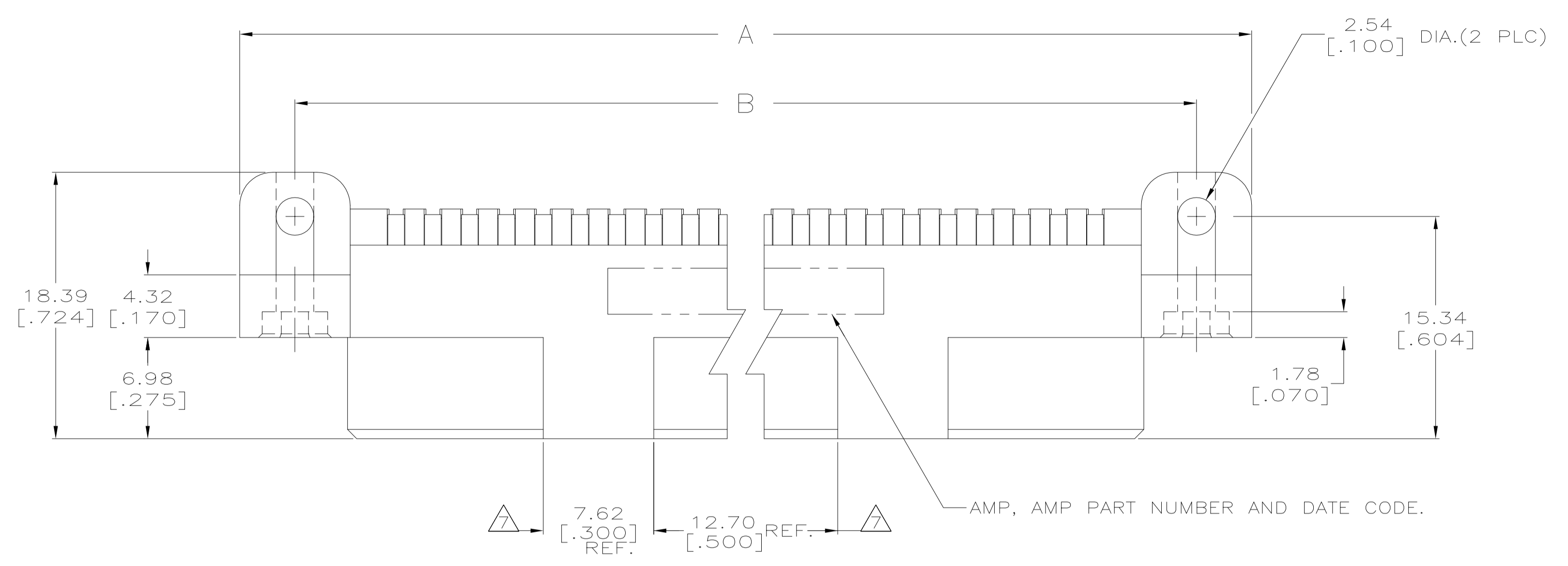
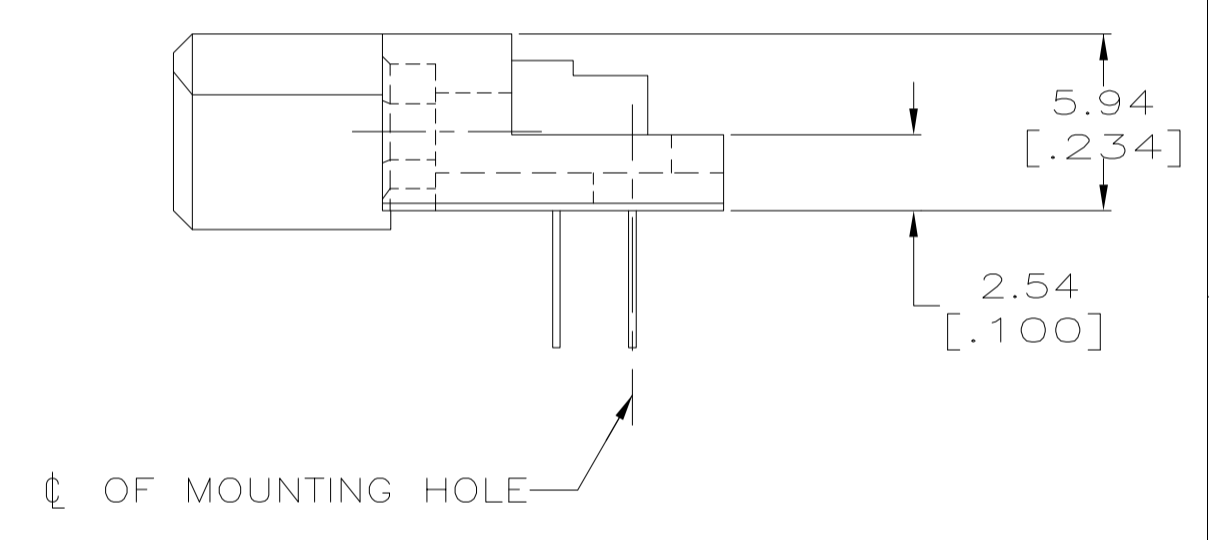
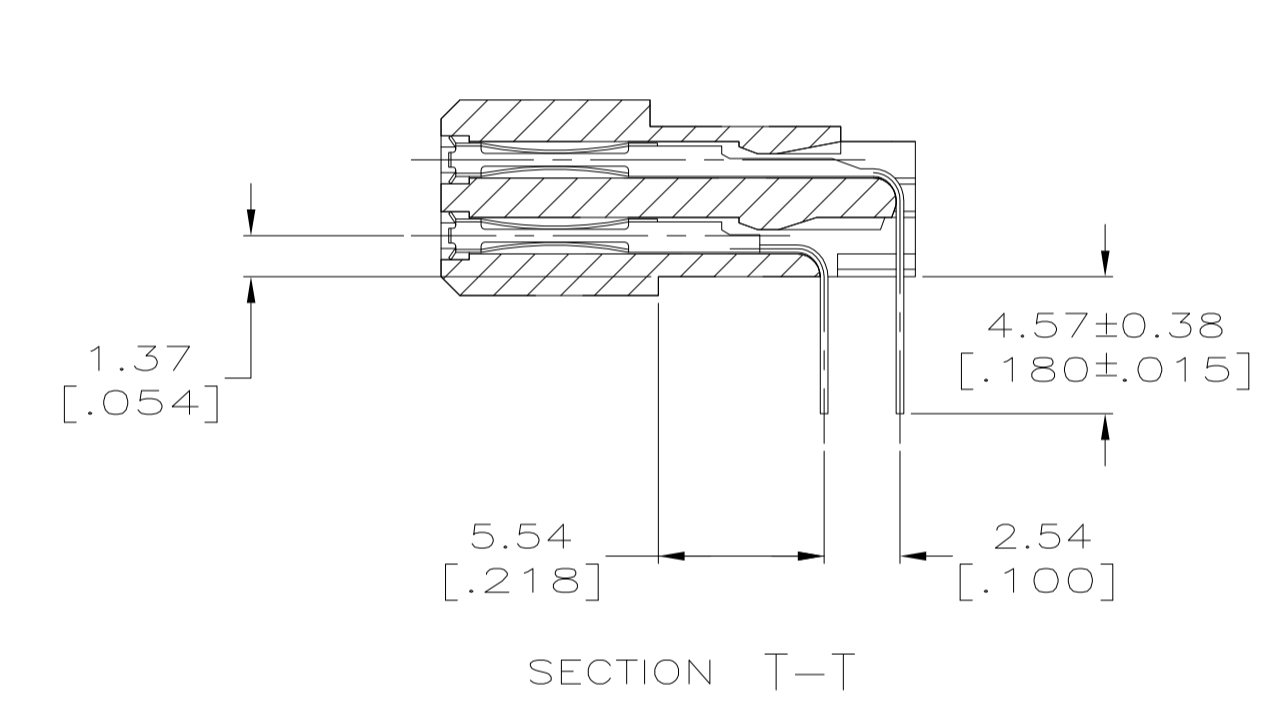

8	OBSOLETE	226.06 [8.900]	89	229.21 [9.024]	240.03 [9.450]	247.65 [9.750]	180	1-5532428-8
8	OBSOLETE	200.66 [7.900]	79	203.81 [8.024]	214.63 [8.450]	222.25 [8.750]	160	1-5532428-6
6		251.46 [9.900]	99	254.61 [10.024]	265.43 [10.450]	273.05 [10.750]	200	1-5532428-5
6		187.96 [7.400]	74	191.11 [7.524]	201.93 [7.950]	209.55 [8.250]	150	1-5532428-4
8		149.86 [5.900]	59	153.01 [6.024]	163.83 [6.450]	171.45 [6.750]	120	1-5532428-1
8		137.16 [5.400]	54	140.31 [5.524]	151.13 [5.950]	158.75 [6.250]	110	1-5532428-0
8		124.46 [4.900]	49	127.61 [5.024]	138.43 [5.450]	146.05 [5.750]	100	5532428-9
8		99.06 [3.900]	39	102.21 [4.024]	113.03 [4.450]	120.65 [4.750]	80	5532428-7
8		86.36 [3.400]	34	89.51 [3.524]	100.33 [3.950]	107.95 [4.250]	70	5532428-6
8		73.66 [2.900]	29	76.81 [3.024]	87.63 [3.450]	95.25 [3.750]	60	5532428-5
8		60.96 [2.400]	24	64.11 [2.524]	74.93 [2.950]	82.55 [3.250]	50	5532428-4
8		48.26 [1.900]	19	51.41 [2.024]	62.23 [2.450]	69.85 [2.750]	40	5532428-3
8		22.86 [.900]	9	26.01 [1.024]	36.83 [1.450]	44.45 [1.750]	20	5532428-1
		E	D	C	B	A	POSN	PART NUMBER

THIS DRAWING IS A CONTROLLED DOCUMENT.

DIMENSIONS: mm [INCHES]
 TOLERANCES UNLESS OTHERWISE SPECIFIED:
 0 PLC ±
 1 PLC ±
 2 PLC ± 0.13[.005]
 3 PLC ±
 4 PLC ±
 ANGLES ±
 FINISH: 1, 2, 3

DWG: J. POLIGNONE 10JUN05
 CHK: A. SHARPE 10JUN05
 APVD: A. SHARPE 10JUN05
 PRODUCT SPEC: ASSEMBLY, RECEPTACLE, RIGHT ANGLE, HDI, LEAD-FREE, 2 ROW WITHOUT GUIDE, 4.57[.180] SOLDER POSTS
 APPLICATION SPEC: NAME: ASSEMBLY, RECEPTACLE, RIGHT ANGLE, HDI, LEAD-FREE, 2 ROW WITHOUT GUIDE, 4.57[.180] SOLDER POSTS
 SIZE: A1 CAGE CODE: 00779 DRAWING NO: C=5532428
 WEIGHT: 0
 MATERIAL: 1, 2, 3
 FINISH: 3

CUSTOMER DRAWING
 SCALE: 4:1
 SHEET: 1 OF 1
 REV: B