

DWG. NO. SD-54280-008

部品構成
PARTS CONSTRUCTION

| 部番 NO. | 部品名 PART NAME | 製品番号 ENG. NO. | 個数 QUAN. | 材質 MATERIAL |
|-----------|---|------------------|-------------|--|
| ① | ハウジングアッセンブリ HOUSING ASS'Y | 53988-0619 | 1 | ハウジング：ガラス入り耐熱樹脂 UL94V-0 色：黒 HOUSING : G.F. HEAT RESISTANT PLASTIC UL94V-0 COLOR : BLACK ターミナル：りん青銅 t0.3 TERMINAL : PHOSPHOR BRONZE t0.3 メッキ仕様 接点部：ニッケル下地金メッキ PLATING CONTACT AREA : GOLD OVER NICKEL 結線部：ニッケル下地錫メッキ WIRE TERMINATION AREA : TIN OVER NICKEL シェル：りん青銅 t0.4 SHELL : PHOSPHOR BRONZE t0.4 メッキ仕様 ニッケル下地錫メッキ PLATING TIN OVER NICKEL |
| ② | カバー A COVER A | 53989-0605 | 1 | ガラス入りポリカーボネイト樹脂 UL94V-0 色：グレー POLYCARBONATE G.F. UL94V-0 COLOR : GRAY |
| ③ | カバー B COVER B | 53990-0605 | 1 | |
| ④ | シェル カバー SHELL COVER | 58302-0628 | 1 | 鋼 t0.4 STEEL t0.4 メッキ仕様：ニッケル下地、錫メッキ PLATING : NICKEL BASE, TIN PLATING |
| ⑤ | ケーブルクランプ CABLE CLAMP | 58303-0000 | 1 | ステンレス鋼 STAINLESS STEEL |
| ⑥ | 十字穴付きなべ小ネジ CROSS RECESSED PAN HEAD MACHINE SCREW | 59832-0009 | 2 | 黄銅(ネジサイズ：M2X4) BRASS (SCREW SIZE : M2X4) |

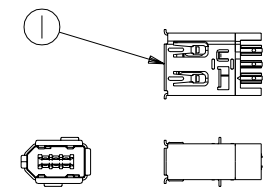

HOUSING ASS'Y

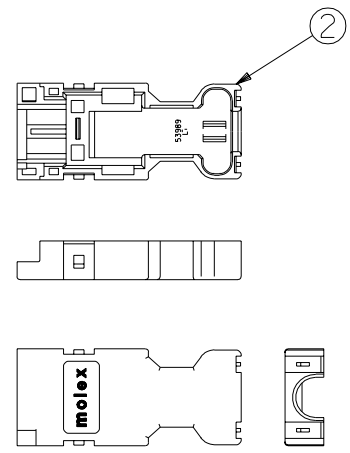

COVER A

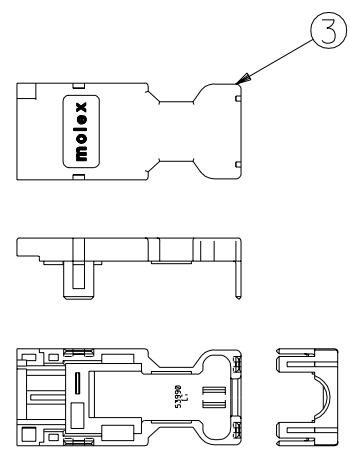

COVER B

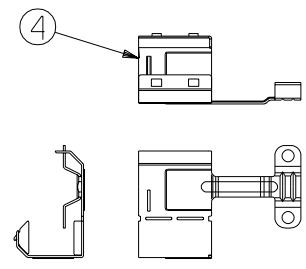

SHELL COVER

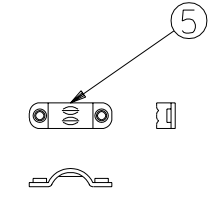

CABLE CLAMP

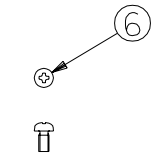

SCREW

54280-0609
MATERIAL No.

| | | | | | | |
|-------------------------|----------------------|-------|--------------------|-------------------------------|--------------------|-------------------------------------|
| 角度 ANGLE | | ±3° | 材料 MATERIAL | | 注参照 SEE NOTES | MOLEX-JAPAN CO.,LTD. 日本モレックス株式会社 |
| 30 以上 OVER | | +0.3 | 仕上げ FINISH | | 注参照 SEE NOTES | |
| 10 以上 OVER 30 未満 UNDER | | +0.25 | 適用電線範囲 WIRE RANGE | | — # — | REVISE ONLY ON CAD SYSTEM |
| 10 未満 UNDER | | +0.2 | 被覆外径 INS. RANGE | | — # — | TITLE 名称 2.0 mm PITCH I/O CONN. |
| 一般公差 GENERAL TOLERANCES | | | DRAWN BY '04/05/18 | | CHK'D BY '04/05/18 | SOCKET SET -LEAD FREE- |
| 記号 LTR | 変更内容 REVISION RECORD | | DR. M.S. | 日付 DATE '04/05/18 | | DWG. NO. SD-54280-008 |
| | | | CHK. M.S. | | | REV 0 |
| | | | | APP'D BY '04/05/18 M.SASAO | 尺度 SCALE 1-1 | |

:MM DIMENSIONS IN METRIC DO NOT SCALE DRAWING

SD-54280-008.S01

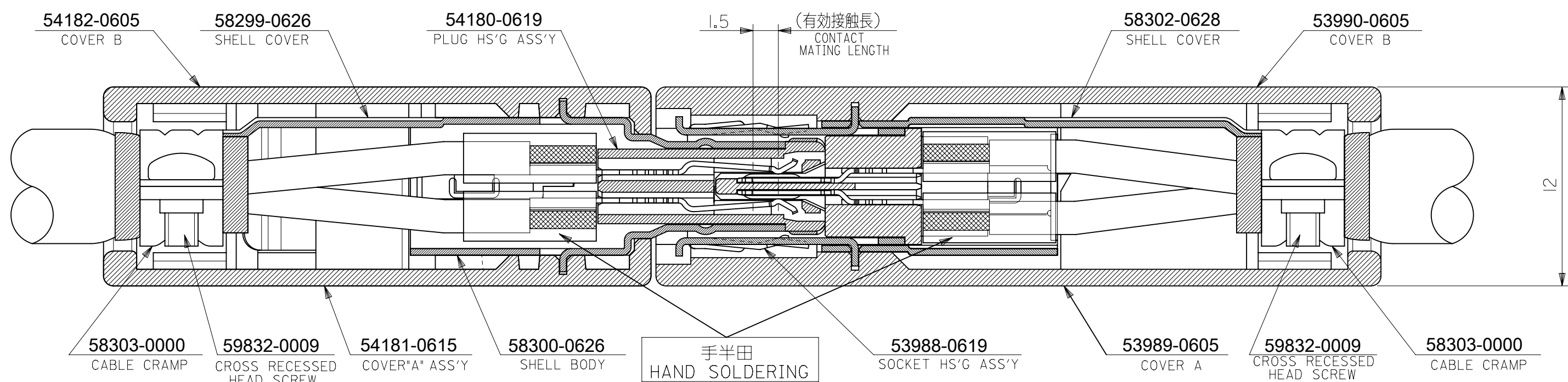
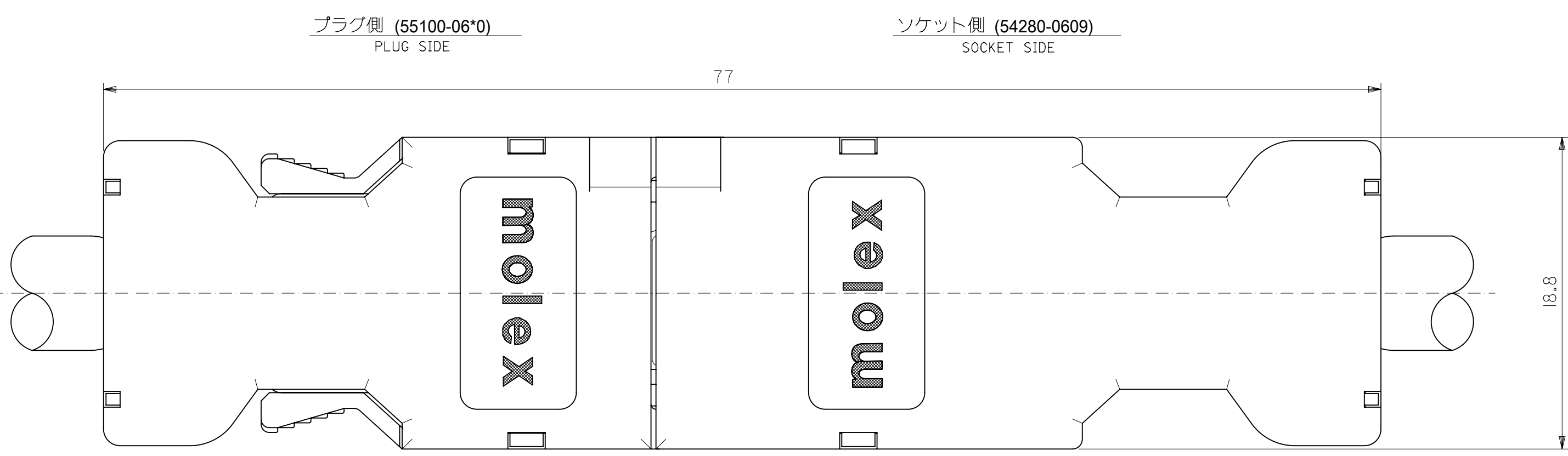

注記
NOTE

- 本製品は55100-0600, 54280-0600の鉛フリー品である。
THIS PRODUCT IS LEAD FREE OF 55100-0600 AND 54280-0600.

THIS DRAWING CONTAINS INFORMATION THAT IS PROPRIETARY TO MOLEX ELECTRONIC TECHNOLOGIES, LLC AND SHOULD NOT BE USED WITHOUT WRITTEN PERMISSION

| | | | | | | | | | | | | |
|--|--|---------------------------------------|----------------|------------------------|-----------------|--|--------|-----------------|----------|-------|---------------|----------------|
| REVISED EC NO: 119030 DRWN: TNAKAGAWA01 CHK'D: KTAKAHASHI APPR: MSASAO | 2017/07/06 | GENERAL TOLERANCES (UNLESS SPECIFIED) | | DIMENSION UNITS | SCALE | <p>2.0 I/O CONN. CROSS-SECT. VIEW OF MATED CONNECTORS -LEAD FREE-</p> <p>PRODUCT CUSTOMER DRAWING</p> <table border="1"> <tr> <td>SERIES</td> <td>MATERIAL NUMBER</td> <td>CUSTOMER</td> </tr> <tr> <td>54280</td> <td>SEE IN FIGURE</td> <td>GENERAL MARKET</td> </tr> </table> | SERIES | MATERIAL NUMBER | CUSTOMER | 54280 | SEE IN FIGURE | GENERAL MARKET |
| | SERIES | MATERIAL NUMBER | CUSTOMER | | | | | | | | | |
| | 54280 | SEE IN FIGURE | GENERAL MARKET | | | | | | | | | |
| | 2017/07/11 | 4 PLACES | ± | MM | 4:1 | | | | | | | |
| | 2017/07/11 | 3 PLACES | ± | DRWN BY | DATE | | | | | | | |
| | 2 PLACES | ± | MNABEI | 2008/04/09 | | | | | | | | |
| | 1 PLACE | ± | CHK'D BY | DATE | | | | | | | | |
| | 0 PLACES | ± | MISOGAYA | 2008/04/10 | | | | | | | | |
| | DRAFT WHERE APPLICABLE MUST REMAIN WITHIN DIMENSIONS | | APPR BY | DATE | | | | | | | | |
| | | | NUKITA | 2008/04/11 | | | | | | | | |
| | | | DRAWING SIZE | THIRD ANGLE PROJECTION | | | | | | | | |
| | | | A3 | | | | | | | | | |
| | | | | | DOCUMENT NUMBER | | | | | | | |
| | | | | | SD-54280-011 | | | | | | | |
| | | | | | DOC TYPE | | | | | | | |
| | | | | | PSD | | | | | | | |
| | | | | | DOC PART | | | | | | | |
| | | | | | 001 | | | | | | | |
| | | | | | SHEET NUMBER | | | | | | | |
| | | | | | 1 OF 1 | | | | | | | |