DABiC-5 32-Bit Serial Input Latched Sink Drivers

Last Time Buy

This part is in production but has been determined to be LAST TIME BUY. This classification indicates that the product is obsolete and notice has been given. Sale of this device is currently restricted to existing customer applications. The device should not be purchased for new design applications because of obsolescence in the near future. Samples are no longer available.

Date of status change: November 1, 2010

Deadline for receipt of LAST TIME BUY orders: April 30, 2011

Recommended Substitutions:

For existing customer transition, and for new customers or new applications, contact Allegro Sales.

NOTE: For detailed information on purchasing options, contact your local Allegro field applications engineer or sales representative.

Allegro MicroSystems, Inc. reserves the right to make, from time to time, revisions to the anticipated product life cycle plan for a product to accommodate changes in production capabilities, alternative product availabilities, or market demand. The information included herein is believed to be accurate and reliable. However, Allegro MicroSystems, Inc. assumes no responsibility for its use; nor for any infringements of patents or other rights of third parties which may result from its use.

DABiC-5 32-Bit Serial Input Latched Sink Drivers

Features and Benefits

- 3.3 to 5 V logic supply range
- To 10 MHz data input rate
- Schmitt trigger inputs for improved noise immunity
- Low-power CMOS logic and latches
- 40 V current sink outputs
- Low saturation voltage
- -40°C operation available

Applications:

- Thermal printheads
- Multiplexed LED displays
- Incandescent lamps

Package: 44-pin PLCC (suffix EP)

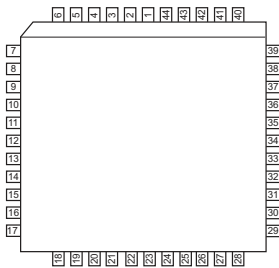

Not to scale

Description

Intended originally to drive thermal printheads, the A6832 has been optimized for low output-saturation voltage, high-speed operation, and pin configurations that are the most convenient for the tight space requirements of high-resolution printheads. These integrated circuits can also be used to drive multiplexed LED displays or incandescent lamps at up to 125 mA peak current. The combination of bipolar and MOS technologies gives the A6832 arrays an interface flexibility beyond the reach of standard buffers and power driver circuits.

The devices each have 32 bipolar NPN open-collector saturated drivers, a CMOS data latch for each of the drivers, two 16-bit CMOS shift registers, and CMOS control circuitry. The high-speed CMOS shift registers and latches allow operation with most microprocessor-based systems. Use of these drivers with TTL may require input pull-up resistors to ensure an input logic high. MOS serial data outputs permit cascading for interface applications requiring additional drive lines.

The A6832 is supplied in a 44-lead plastic leaded chip carrier, for surface-mount applications requiring minimum area. These devices are lead (Pb) free, with 100% matte tin plated leadframes.

Functional Block Diagram

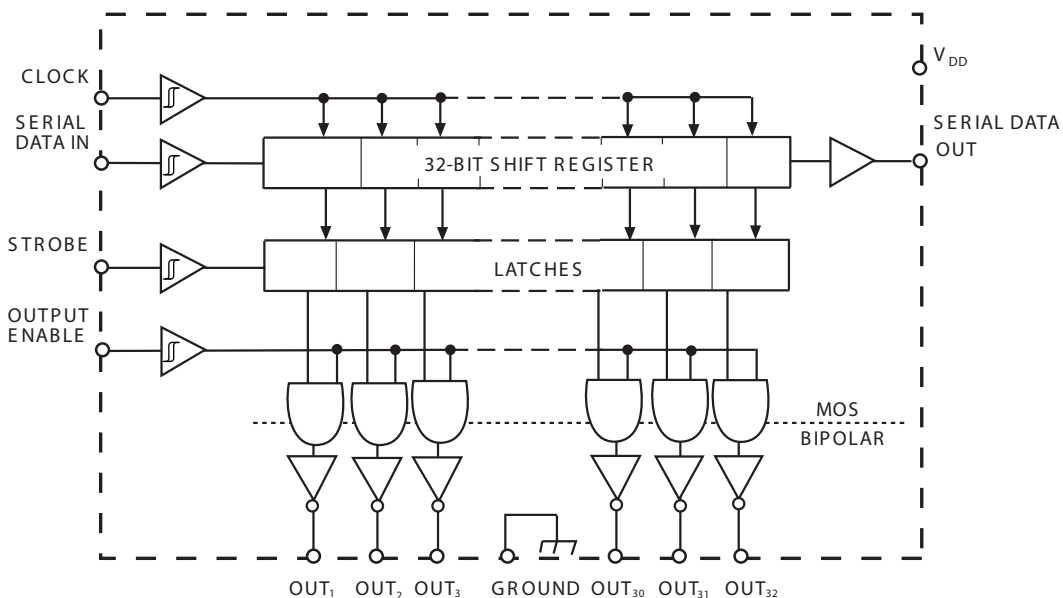

Selection Guide

Part Number	Packing	Operating Temperature (°C)	Package
A6832EEPTR-T	450 pieces per reel	-20 to 85	44-pin PLCC
A6832SEPTR-T	450 pieces per reel	-40 to +85	



Absolute Maximum Ratings

Characteristic	Symbol	Notes	Rating	Unit
Logic Supply Voltage	V_{DD}		7	V
Input Voltage Range	V_{IN}	Caution: CMOS devices have input-static protection, but are susceptible to damage when exposed to extremely high static-electrical charges.	-0.3 to $V_{DD} + 0.3$	V
Output Voltage	V_{OUT}		40	V
Continuous Output Current	I_{OUT}		125	mA
Package Power Dissipation	P_D	See Allowable Power Dissipation chart.	-	-
Operating Ambient Temperature	T_A	Range E	-40 to 85	°C
		Range S	-20 to 85	°C
Maximum Junction Temperature	$T_{J(max)}$		150	°C
Storage Temperature	T_{stg}		-55 to 150	°C

Allowable Power Dissipation, P_D^*

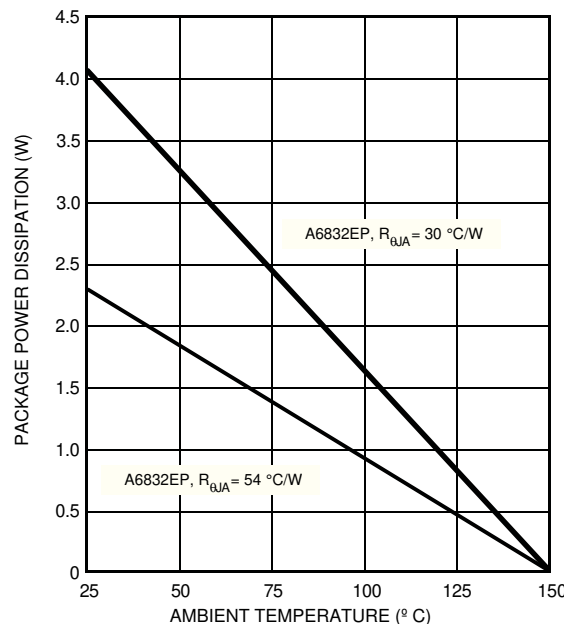

*Additional thermal information is available on the Allegro Web site.

ELECTRICAL CHARACTERISTICS¹ Unless otherwise noted: T_A = 25°C, logic supply operating voltage V_{dd} = 3.0 V to 5.5 V

Characteristic	Symbol	Test Conditions	V _{dd} = 3.3 V			V _{dd} = 5 V			Units
			Min.	Typ.	Max.	Min.	Typ.	Max.	
Output Leakage Current	I _{CEX}	V _{OUT} = 40 V	–	–	10	–	–	10	μA
Collector–Emitter Saturation Voltage	V _{CE(SAT)}	I _{OUT} = 50 mA	–	–	275	–	–	275	mV
		I _{OUT} = 100 mA	–	–	550	–	–	550	mV
Input Voltage	V _{IN(1)}		2.2	–	–	3.3	–	–	V
	V _{IN(0)}		–	–	1.1	–	–	1.7	V
Input Current	I _{IN(1)}	V _{IN} = V _{DD}	–	< 0.01	1.0	–	< 0.01	1.0	μA
	I _{IN(0)}	V _{IN} = 0 V	–	< –0.01	–1.0	–	< –0.01	–1.0	μA
Serial Data Output Voltage	V _{OUT(1)}	I _{OUT} = –200 μA	2.8	3.05	–	4.5	4.75	–	V
	V _{OUT(0)}	I _{OUT} = 200 μA	–	0.15	0.3	–	0.15	0.3	V
Maximum Clock Frequency ²	f _c		10	–	–	10	–	–	MHz
Logic Supply Current	I _{DD(1)}	One output on, I _{OUT} = 100 mA	–	–	6.0	–	–	6.0	mA
	I _{DD(0)}	All outputs off	–	–	100	–	–	100	μA
Output Enable-to-Output Delay	t _{dis(BQ)}	V _{CC} = 50 V, R ₁ = 500 Ω, C ₁ ≤ 30 pF	–	–	1.0	–	–	1.0	μs
	t _{en(BQ)}	V _{CC} = 50 V, R ₁ = 500 Ω, C ₁ ≤ 30 pF	–	–	1.0	–	–	1.0	μs
Strobe-to-Output Delay	t _{p(STH-QL)}	V _{CC} = 50 V, R ₁ = 500 Ω, C ₁ ≤ 30 pF	–	–	1.0	–	–	1.0	μs
	t _{p(STH-QH)}	V _{CC} = 50 V, R ₁ = 500 Ω, C ₁ ≤ 30 pF	–	–	1.0	–	–	1.0	μs
Output Fall Time	t _f	V _{CC} = 50 V, R ₁ = 500 Ω, C ₁ ≤ 30 pF	–	–	1.0	–	–	1.0	μs
Output Rise Time	t _r	V _{CC} = 50 V, R ₁ = 500 Ω, C ₁ ≤ 30 pF	–	–	1.0	–	–	1.0	μs
Clock-to-Serial Data Out Delay	t _{p(CH-SQX)}	I _{OUT} = ±200 μA	–	50	–	–	50	–	ns

¹Positive (negative) current is defined as conventional current going into (coming out of) the specified device pin.

²Operation at a clock frequency greater than the specified minimum value is possible but not warranted.

Truth Table

Serial Data Input	Clock Input	Shift Register Contents						Serial Data Output	Strobe Input	Latch Contents						Output Enable Input	Output Contents					
		I ₁	I ₂	I ₃	...	I _{N-1}	I _N			I ₁	I ₂	I ₃	...	I _{N-1}	I _N		I ₁	I ₂	I ₃	...	I _{N-1}	I _N
H	⌋	H	R ₁	R ₂	...	R _{N-2}	R _{N-1}	R _{N-1}														
L	⌋	L	R ₁	R ₂	...	R _{N-2}	R _{N-1}	R _{N-1}														
X	⌋	R ₁	R ₂	R ₃	...	R _{N-1}	R _N	R _N														
		X	X	X	...	X	X	X	L	R ₁	R ₂	R ₃	...	R _{N-1}	R _N							
		P ₁	P ₂	P ₃	...	P _{N-1}	P _N	P _N	H	P ₁	P ₂	P ₃	...	P _{N-1}	P _N	H						
										X	X	X	...	X	X	L	H	H	H	...	H	H

L = Low Logic Level
H = High Logic Level
X = Irrelevant
P = Present State
R = Previous State

Timing Requirements and Specifications
(Logic Levels are V_{DD} and Ground)

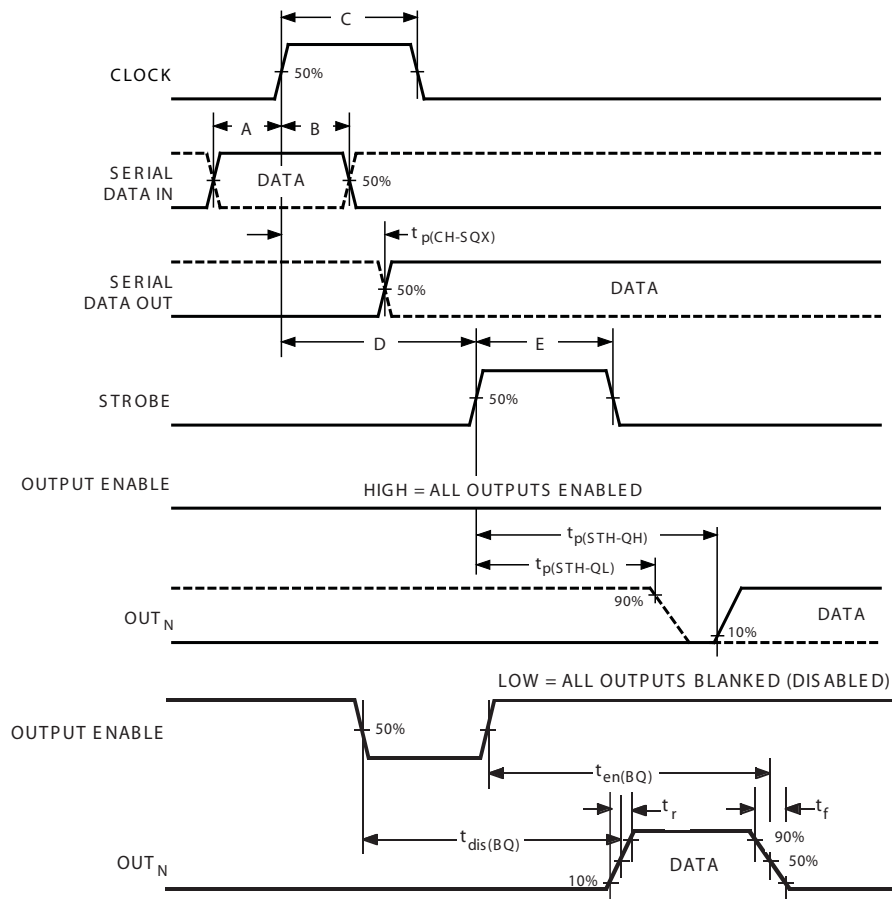

Key	Description	Symbol	Time (ns)
A	Data Active Time Before Clock Pulse (Data Set-Up Time)	$t_{su(D)}$	25
B	Data Active Time After Clock Pulse (Data Hold Time)	$t_h(D)$	25
C	Clock Pulse Width	$t_w(CH)$	50
D	Time Between Clock Activation and Strobe	$t_{su(C)}$	100
E	Strobe Pulse Width	$t_w(STH)$	50

NOTE: Timing is representative of a 10 MHz clock. Higher speeds may be attainable; operation at high temperatures will reduce the specified maximum clock frequency.

Serial Data present at the input is transferred to the shift register on the logical 0 to logical 1 transition of the CLOCK input pulse. On succeeding CLOCK pulses, the registers shift data information towards the SERIAL DATA OUTPUT. The SERIAL DATA must appear at the input prior to the rising edge of the CLOCK input waveform.

Information present at any register is transferred to the respective latch when the STROBE is high (serial-to-parallel conversion). The

latches will continue to accept new data as long as the STROBE is held high. Applications where the latches are bypassed (STROBE tied high) will require that the OUTPUT ENABLE input be low during serial data entry.

When the OUTPUT ENABLE input is low, the output sink drivers are disabled (OFF). The information stored in the latches is not affected by the OUTPUT ENABLE input. With the OUTPUT ENABLE input high, the outputs are controlled by the state of their respective latches.

Pin-out Diagram

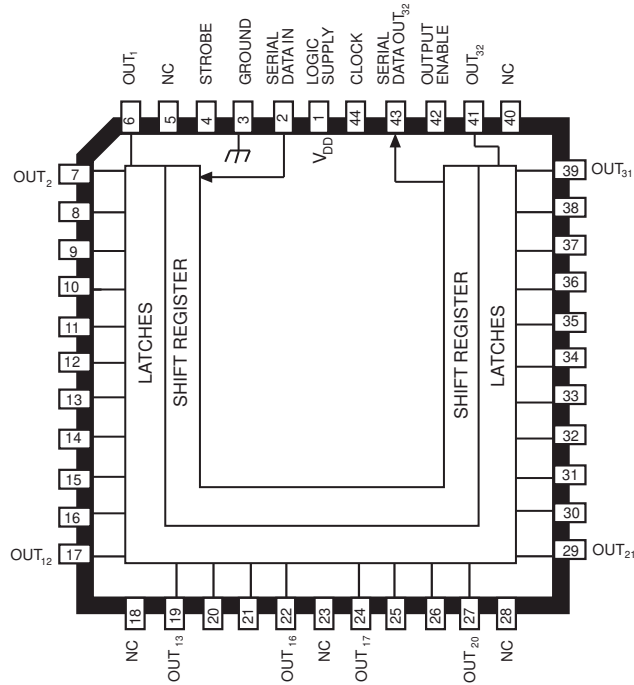

Typical Input Circuit

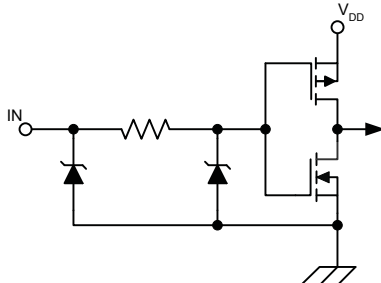

Typical Output Driver

