

REVISIONS					
REV	ECO	DESCRIPTION	DATE	BY	APPR
B1	-	RELEASED DRAWING	JUN-30-2014	BEN	TOMMY
B2	-	VOLTAGE UPDATE AND ADD KEY ICON	Nov-27-2020	Ronald	Tommy

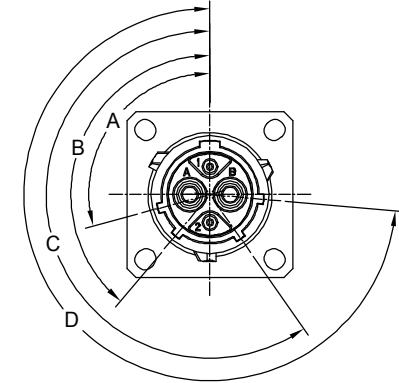
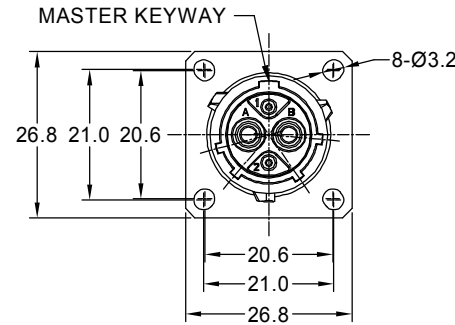
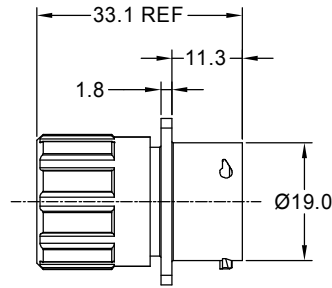

NOTES : (UNLESS OTHERWISE SPECIFIED)

- MATERIAL :
 - SHELL : ZINC ALLOY , NICKEL PLATED.
 - INSERT : THERMOPLASTIC , UL94 V-0.
 - END CAP : THERMOPLASTIC , UL94 V-0.
 - PLASTIC BUSHING : THERMOPLASTIC , UL94 V-0.
 - SEAL GASKET : NBR/SILICONE RUBBER.
 - O-RING : NBR/SILICONE RUBBER.
 - WIRE SEAL : SILICONE RUBBER.
- SPECIFICATIONS :
 - RATED CURRENT :
 - 2.5mm CONTACT 23A (MAX) .
 - 20# CONTACT 5A (MAX).
 - RATED VOLTAGE : 500V (AC/DC) .
 - OPERATING TEMPERATURE : SEE CHART.
 - DIELECTRIC WITHSTANDING VOLTAGE : LESS THAN 2 MILLIAMPS CURRENT LEAKAGE@2000 VOLTS AC.
 - INSULATION RESISTANCE : 5000 MEGOHMS MIN.
 - IP--CLASS : IP67 (MATED CONDITION).
 - MATING CYCLES DURABILITY : 500 CYCLES MIN.
 - ROHS COMPLIANT.
- SUITABLE CONTACTS : 2.5mm & 20# CONTACTS.
- ALL DIMENSIONS ARE FOR REFERENCE USE ONLY.
- CONTACT SIZE AND REAR SEAL WIRE RANGE :

CONTACT SIZE	MIN. INSUL O.D.	MAX. INSUL O.D.	WIRE RANGE
2.5mm	Ø3.3mm	Ø4.3mm	14 - 12AWG
20#	Ø1.6mm	Ø2.6mm	30 - 20AWG

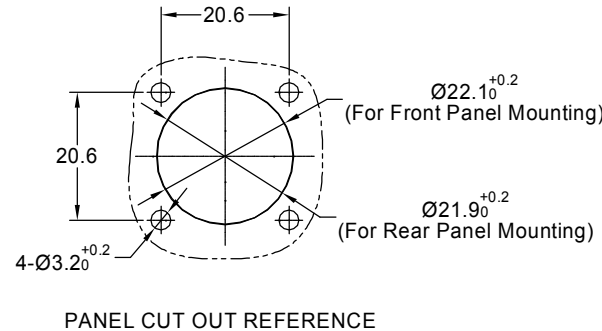

KEY POS	PART NUMBER		A	B	C	D
	-40°C ~ 105°C	-40°C ~ 125°C				
N	RT00122SNHEC	RT00122SNHEC03	105°	140°	215°	265°
W	RT00122SWHEC	RT00122SWHEC03	60°	140°	215°	265°
X	RT00122SXHEC	RT00122SXHEC03	105°	155°	215°	265°
Y	RT00122SYHEC	RT00122SYHEC03	105°	140°	225°	265°
Z	RT00122SZHEC	RT00122SZHEC03	105°	140°	215°	295°

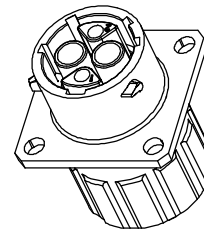

QUANTITY	SEE PART NUMBER CHART	DESCRIPTION	ITEM
	PART NUMBER		
MATERIALS LIST			
UNLESS OTHERWISE SPECIFIED 1) All dimensions are in metric(mm). 2) Tolerances are as follows: 1 PL DEC ±0.30 2 PL DEC ±0.15 3 PL DEC ±0.08 Fractions ±1/64 Angles ±1° 3) Note reference =		SIGNATURES DRAWN: Ronald DATE: Nov-27-20 CHECKED: Ronald DATE: Nov-28-20 ENGINEER: APPROVAL: Tommy DATE: Nov-28-20 CUSTOMER:	Amphenol Sine Systems - www.amphenol-sine.com 44724 Morley Drive Clinton Township, MI 48036
MATERIAL SPECIFICATIONS: PROCESS SPECIFICATIONS: NEXT ASSY:		THIS DRAWING IS SUPPLIED FOR INFORMATION ONLY. DESIGN FEATURES, SPECIFICATIONS AND PERFORMANCE DATA SHOWN HEREON ARE THE PROPERTY OF THE AMPHENOL CORPORATION. NO RIGHTS OF REPRODUCTION ARE IMPLIED. ALL DIMENSIONS ARE SUBJECT TO NORMAL MANUFACTURING VARIATIONS.	ECOMATE RM, RECEPTACLE, SIZE 12,2POS, SOCKET, END CAP. SIZE TYPE DWG NO: B C- RT00122S*HECx B2 SCALE NONE SHEET 1 OF 1

TITLE: ECOMATE RM, RECEPTACLE, SIZE 12,2POS, SOCKET, END CAP
 DWG NO.:
 RT00122S*HECx
 REV: B2
 SH: 1
 OF: 1