

NOTES:

1. MATERIALS AND FINISHES:
 BODY & COUPLING NUT - BRASS, NICKEL PLATING
 INSULATOR & INSULATOR DISC - PTFE, NATURAL
 CONTACT - BRASS, GOLD PLATING
 GASKETS - SILICONE RUBBER, RED
 RETAINING RING - STAINLESS STEEL, NATURAL
 FERRULE - COPPER, NICKEL PLATING
 HEAT SHRINK TUBING - CROSSLINKED POLYOLEFIN, BLACK
2. ELECTRICAL:
 A. IMPEDANCE: 50 OHM
 B. FREQUENCY RANGE: DC - 8 GHz
 C. VSWR: 1.20 MAX.
3. MECHANICAL:
 A. DURABILITY: 500 CYCLES MIN.
 B. TEMPERATURE RANGE: -65°C TO +165°C

4. PACKAGING:
 A. QUANTITY: SINGLE PACK
 B. MARKING: BAG TO BE MARKED
 "AMPHENOL RF, 901-10660 AND DATE CODE"
5. CABLE ASSEMBLY INSTRUCTIONS:
 A. TRIM CABLE AS SHOWN.
 B. SLIDE HEAT SHRINK TUBING, FERRULE AND INSULATOR DISC ONTO CABLE.
 C. SOLDER CABLE CENTER CONDUCTOR TO CONTACT.
 D. INSERT CABLE, UNTIL IT BOTTOMS, WITH FOIL ENTERING CONNECTOR AND BRAID OVER KNURL.
 E. CRIMP FERRULE OVER BRAID WITH 0.213" HEX DIE.
 F. APPLY HEAT SHRINK TUBING OVER FERRULE.
 G. HEAT SHRINK TUBING SHOULD FULLY (360°) COVER THE BUMP ON BODY AND END WITHIN AREA "A".
6. ADHESIVE LINED HEAT SHRINK TUBE (ITEM 10) IS INCLUDED (NOT SHOWN).

7 SHOWS CABLE ENTRY DIMENSIONS.

THIRD ANGLE PROJ.

REVISIONS

REV	DESCRIPTION	DATE	ECN	APPR
A	RELEASE TO MFG.	--	--	KR

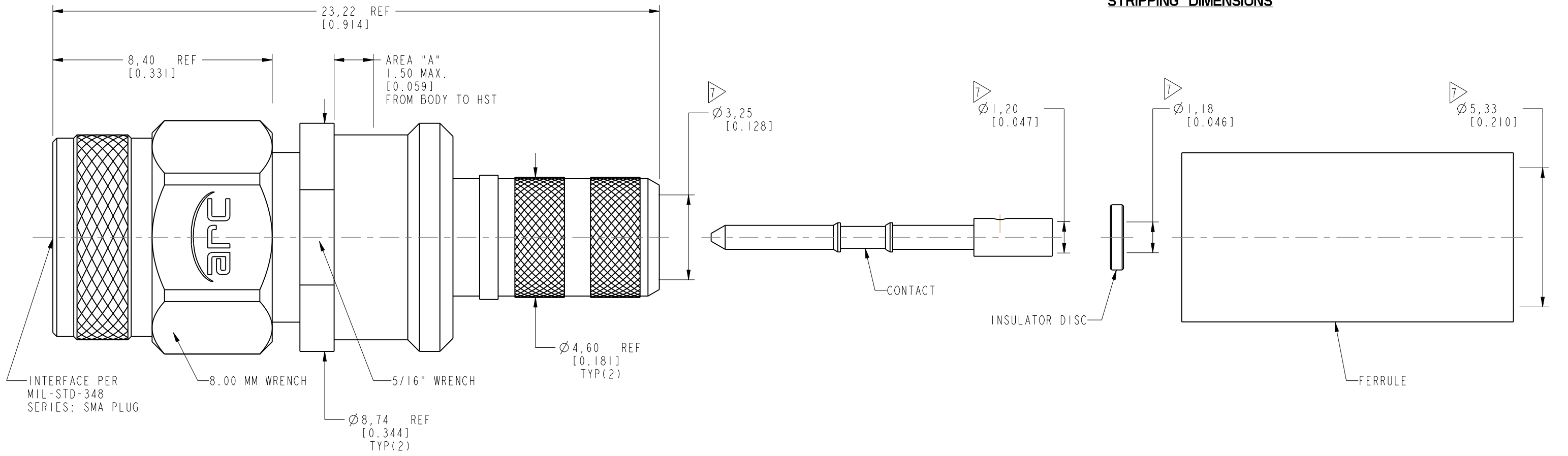
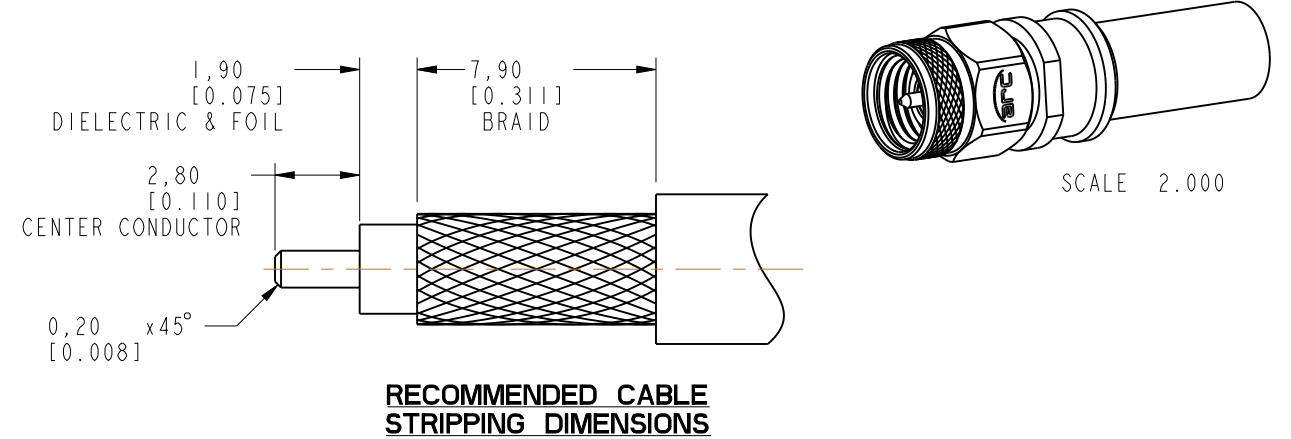

PRELIMINARY ISSUE

CUSTOMER OUTLINE DRAWING

ALL OTHER SHEETS ARE FOR INTERNAL USE ONLY

UNLESS OTHERWISE SPECIFIED, DIMENSIONS ARE IN METRIC AND TOLERANCES ARE: <0.5mm ±0.05mm 0.5 - 6mm ±0.1mm 6 - 30mm ±0.2mm 30 - 120mm ±0.3mm ANGLES ±1°	MATERIAL	DRAWN	DATE	TITLE	Amphenol RF www.amphenolrf.com	
	SEE NOTES	KAVI S	06-Feb-19	SMA STR PLUG IP 67 FOR LMR 200 CABLE		
NOTICE - These drawings, specifications, or other data (1) are, and remain the property of Amphenol corp. (2) must be returned upon request; and (3) are confidential and not to be disclosed to any person other than those to whom they are given by Amphenol Corp. the furnishing of these drawings, specifications, or other data by Amphenol Corp., or to any other person to anyone for any purpose is not to be regarded by implication or otherwise in any manner licensing, granting rights to permitting such holder or any other person to manufacture, use or sell any product, process or design, patented or otherwise, that may in any way be related to or disclosed by said drawings, specifications, or other data.	REFERENCE	ENGINEER	DATE	SCALE: 6.8:1.0	DRAWING NO. 901-10660	
	EAR# 8898	KAVI S	06-Feb-19	DATE	SHEET 2 OF 2	ITEM NO. 901-10660
REF: 901-10639	CONFIGURATION LEVEL: In Work	APPROVED	DATE	DWG SIZE B	REV A	PART NO. 901-10660
FINISH		CAD FILE				