

THIS DRAWING IS UNPUBLISHED. RELEASED FOR PUBLICATION
 © COPYRIGHT BY TYCO ELECTRONICS CORPORATION. ALL RIGHTS RESERVED.

DESIGNED FOR USE WITH RG-141/U	
CABLE ENTRY DIAMETER MINIMUM	
COLLAR	.122
CLAMP NUT	.220
CONTACT	.042

REVISIONS			
P	LTR	DESCRIPTION	DATE
B		REV PER ECO 07-027471	1/16/2008
			DWN APVD
			DW JL

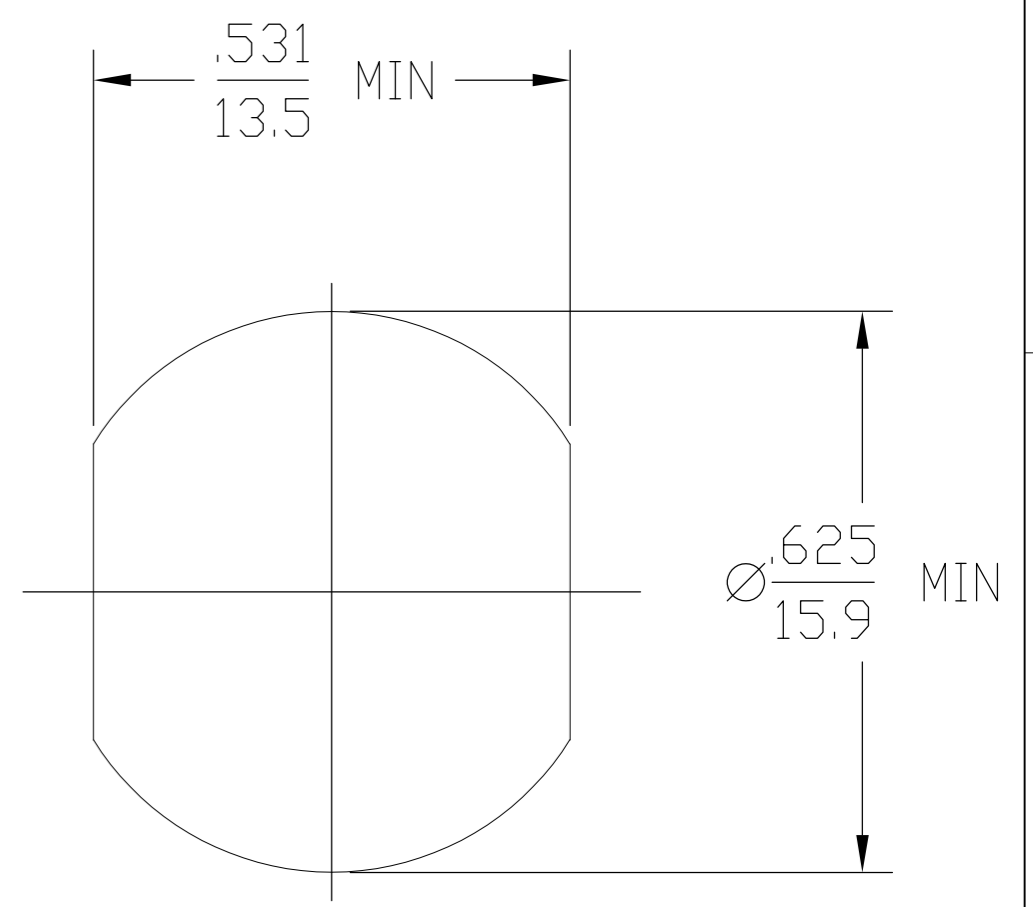
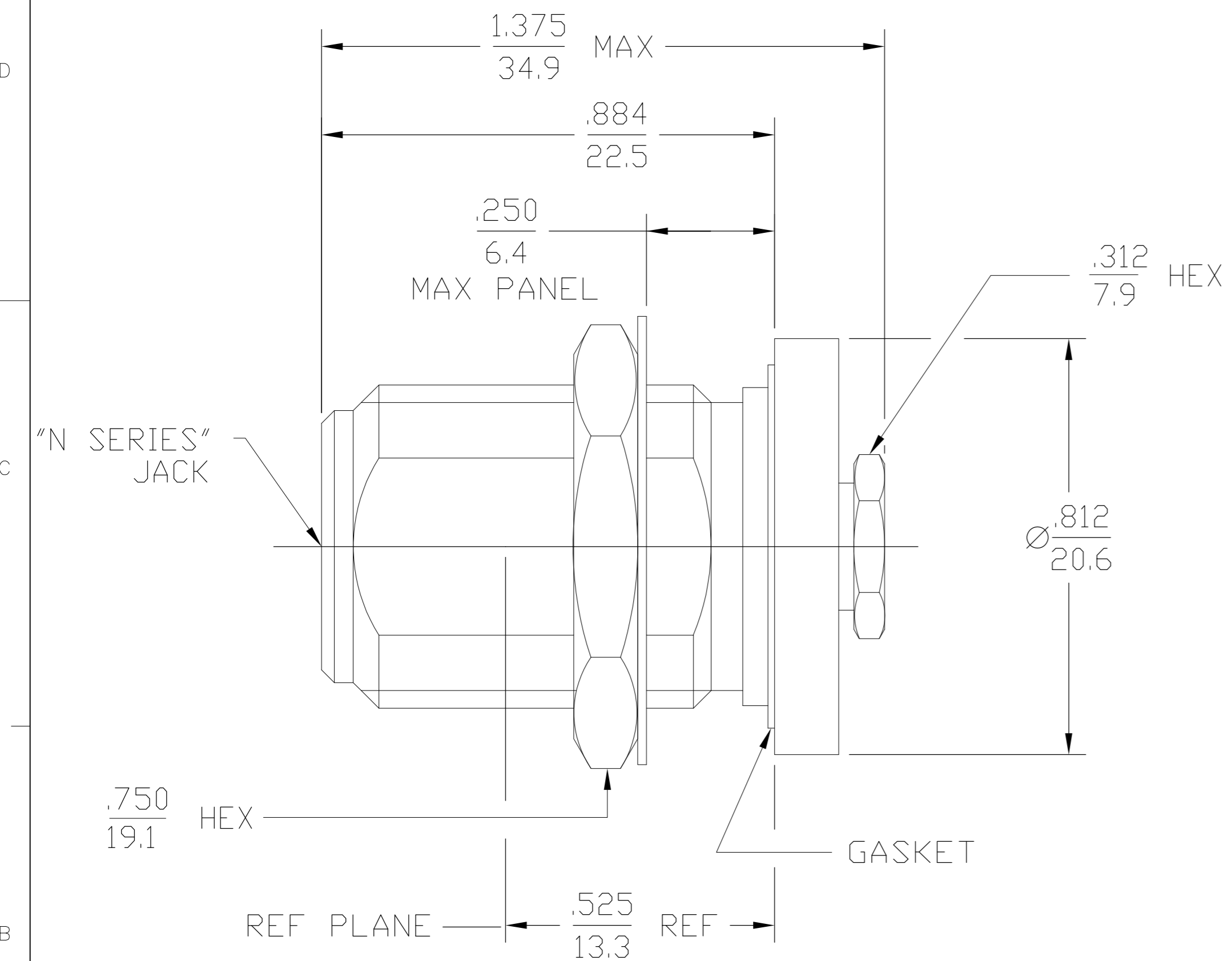

1057138-1
PART NUMBER

COMPONENT	MATERIAL	FINISH
HOUSING	BRASS PER ASTM-B-16, HALF HARD	NICKEL PLATE PER QQ-N-290
CLAMP NUT	PTFE FLUOROCARBON PER ASTM-D-1457	N/A
MOUNTING NUT	BRASS PER ASTM-B-16, HALF HARD	GOLD PLATE PER MIL-G-45204
DIELECTRIC	PHOSPHOR BRONZE PER QQ-B-750, GRADE B2 OR TIN BRASS PER ASTM-B-591	NICKEL PLATE PER QQ-N-290
CENTER CONTACT	BRASS PER ASTM-B-16, HALF HARD	GOLD PLATE PER MIL-G-45204
LOCKWASHER	SILICONE RUBBER PER ZZ-R-765	N/A
COLLAR	BRASS PER ASTM-B-16, HALF HARD	GOLD PLATE PER MIL-G-45204
GASKET		

THIS DRAWING IS A CONTROLLED DOCUMENT.		DWN RR 9/25/79	Tyco Electronics Corporation Harrisburg, PA 17105-3608	
DIMENSIONS: INCHES		CHK RDS 10-1-79	NAME N SERIES STRAIGHT BULKHEAD FEEDTHRU CABLE JACK CLAMP ATTACHMENT (3004-7341-10)	
TOLERANCES UNLESS OTHERWISE SPECIFIED:		APVD PFH 10-3-79	SIZE A2	CAGE CODE 00779
0 PLC ± -		PRODUCT SPEC -	DRAWING NO C=1057138-1	RESTRICTED TO -
1 PLC ± -		APPLICATION SPEC 30-045	SCALE 1:1	SHEET 1 of 1
2 PLC ± -		WEIGHT -	REV B	
3 PLC ± .005		CUSTOMER DRAWING		
4 PLC ± - 1°				
FINISH -				