



OFF-LINE POWER SUPPLY CONTROLLER

FEATURES

- Transformerless Off-Line Power Supply
- Wide 100-VDC to 400-VDC Allowable Input Range
- Fixed 5-VDC or Adjustable Low-Voltage Output
- Output Sinks 200 mA, Sources 150 mA Into a MOSFET Gate
- Uses Low-Cost SMD Inductors
- Short Circuit Protected
- Optional Isolation Capability

DESCRIPTION

The UCC3888 controller is optimized for use as an off-line, low-power, low-voltage, regulated bias supply. The unique circuit topology utilized in this device can be visualized as two cascaded flyback converters, each operating in the discontinuous mode, both driven from a single external power switch. The significant benefit of this approach is the ability to achieve voltage conversion ratios as high as 400 V to 2.7 V with no transformer and low internal losses.

The control algorithm utilized by the UCC3888 sets the switch on time inversely proportional to the input line voltage and sets the switch off time inversely proportional to the output voltage. This action is automatically controlled by an internal feedback loop and reference. The cascaded configuration allows a voltage conversion from 400 V to 2.7 V to be achieved with a switch duty cycle of 7.6%. This topology also offers inherent short circuit protection because as the output voltage falls to zero, the switch-off time approaches infinity.

The output voltage is set internally to 5 V. It can be programmed for other output voltages with two external resistors. An isolated version can be achieved with this topology as described further in Unitrode Application Note U-149.

TYPICAL APPLICATION

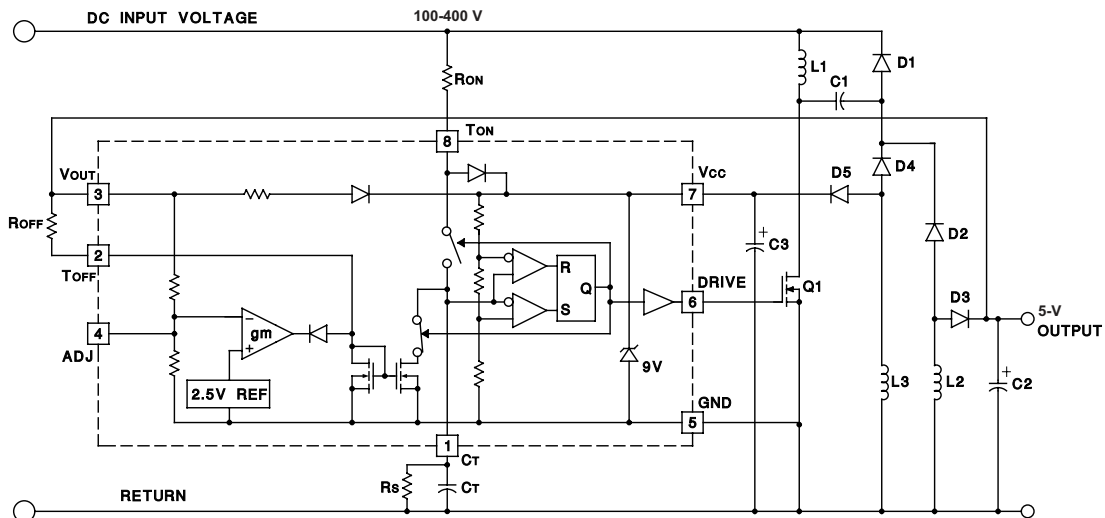

Note: This device incorporates patented technology used under license from Lambda Electronics, Inc.

UDG-96013



Please be aware that an important notice concerning availability, standard warranty, and use in critical applications of Texas Instruments semiconductor products and disclaimers thereto appears at the end of this data sheet.

THEORY OF OPERATION

With reference to the application diagram below, when input voltage is first applied, the current through R_{ON} into T_{ON} is directed to V_{CC} where it charges the external capacitor, C_3 , connected to V_{CC} . As voltage builds on V_{CC} , an internal undervoltage lockout holds the circuit off and the output at DRIVE low until V_{CC} reaches 8.4 V. At this time, DRIVE goes high, turning on the power switch, Q1, and redirecting the current into T_{ON} to the timing capacitor, C_T . C_T charges to a fixed threshold with a current $I_{CHG} = 0.8 \cdot (V_{IN} - 4.5 \text{ V})/R_{ON}$. Because DRIVE is high only as long as C_T charges, the power switch on time will be inversely proportional to line voltage. This provides a constant (line voltage) • (switch on time) product.

At the end of the on time, Q1 is turned off, and the current through R_{ON} is again diverted to V_{CC} . Thus the current through R_{ON} , which charges C_T during the on time, contributes to supplying power to the chip during the off time.

The power switch off time is controlled by the discharge of C_T , which, in turn, is programmed by the regulated output voltage. The relationship between C_T discharge current, I_{DCHG} , and output voltage is illustrated as follows:

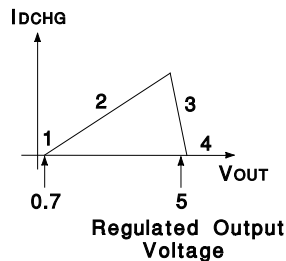

Region 1. When $V_{OUT} = 0$, the off time is infinite. This feature provides inherent short circuit protection. However, to ensure output voltage startup when the output is not a short, a high-value resistor, R_S , is placed in parallel with C_T to establish a minimum switching frequency.

Region 2. As V_{OUT} rises above approximately 0.7 V to its regulated value, I_{DCHG} is defined by R_{OFF} , and is equal to:

$$I_{DCHG} = (V_{OUT} - 0.7V) / R_{OFF}$$

As V_{OUT} increases, I_{DCHG} increases reducing off time. The operating frequency increases and V_{OUT} rises quickly to its regulated value.

Region 3. In this region, a transconductance amplifier reduces I_{DCHG} to maintain a regulated V_{OUT} .

Region 4. If V_{OUT} should rise above its regulation range, I_{DCHG} falls to zero and the circuit returns to the minimum frequency established by R_S and C_T .

The range of switching frequencies is established by R_{ON} , R_{OFF} , R_S , and C_T as follows:

$$\text{Frequency} = 1/(T_{ON} + T_{OFF})$$

$$T_{ON} = R_{ON} \cdot C_T \cdot 4.6 \text{ V}/(V_{IN} - 4.5 \text{ V})$$

$$T_{OFF} (\text{max}) = 1.4 \cdot R_S \cdot C_T \text{ Regions 1 and 4}$$

$$T_{OFF} = R_{OFF} \cdot C_T \cdot 3.7 \text{ V}/(V_{OUT} - 0.7 \text{ V}) \text{ Region 2, excluding the effects of } R_S, \text{ which have a minimal impact on } T_{OFF}.$$

The above equations assume that V_{CC} equals 9 V. The voltage at T_{ON} increases from approximately 2.5 V to 6.5 V while C_T is charging. To take this into account, V_{IN} is adjusted by 4.5 V in the calculation of T_{ON} . The voltage at T_{OFF} is approximately 0.7 V.

DESIGN EXAMPLE

The UCC3888 regulates a 5 volt, 1 Watt nonisolated DC output from AC inputs between 80 and 265 volts. In this example, the IC is programmed to deliver a maximum on time gate drive pulse width of 2.2 microseconds which occurs at 80 VAC. The corresponding switching frequency is approximately 100 kHz at low line, and overall efficiency is approximately 50%. Additional design information is available in Unitrode Application Note U-149.

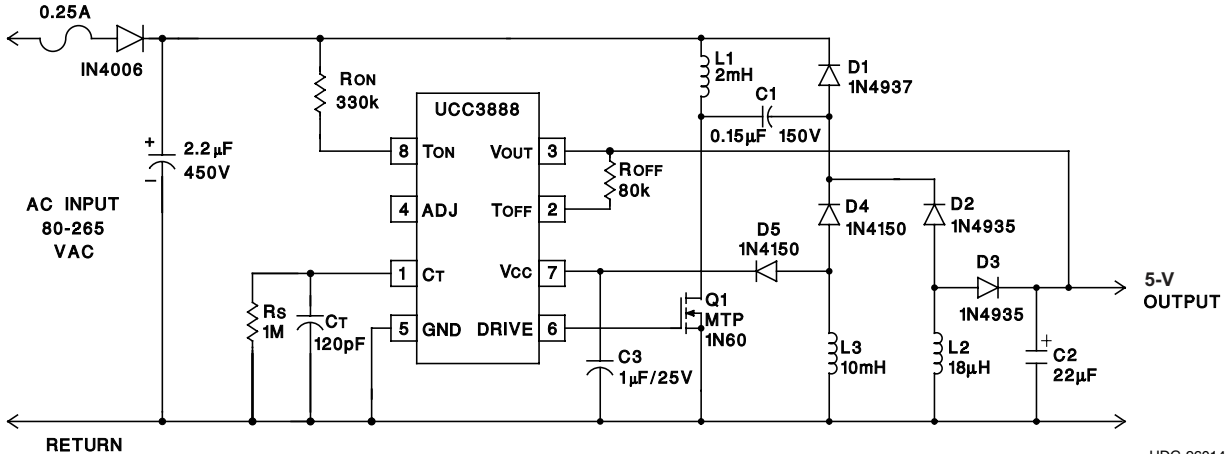

UDG-96014

ABSOLUTE MAXIMUM RATINGS⁽¹⁾

	VALUE	UNIT
I_{CC}	8	mA
Current into T _{ON} Pin	1.5	
Voltage on V _{OUT} Pin	20	V
Current into T _{OFF} Pin	250	µA
Storage temperature	-65 to 150	°C

(1) Unless otherwise indicated, voltages are referenced to ground and currents are positive into, negative out of, the specified terminals.

N OR J, D PACKAGE (TOP VIEW)

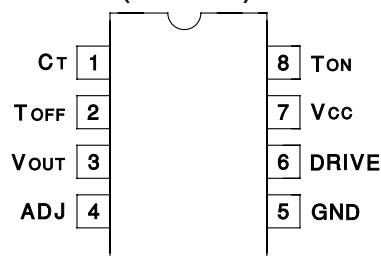

ELECTRICAL CHARACTERISTICS

Unless otherwise stated, these specifications hold for $T_A = 0^\circ\text{C}$ to 70°C for the UCC3888, and -40°C to 85°C for the UCC2888. No load at DRIVE pin ($C_{LOAD} = 0$).

PARAMETER	TEST CONDITIONS	MIN	TYP	MAX	UNIT
General					
V_{CC} Zener voltage	$I_{CC} < 1.5 \text{ mA}$	8.6	9	9.3	V
Startup current	$V_{OUT} = 0$		150	250	μA
Operating current $I(V_{CC})$	$V_{CC} = V_{CC(zener)} - 100 \text{ mV}$, $F = 150 \text{ kHz}$		1.2	2.5	mA
Under-Voltage-Lockout					
Start threshold	$V_{OUT} = 0$	8	8.4	8.8	V
Minimum operating voltage after start	$V_{OUT} = 0$	6	6.3	6.6	
Hysteresis	$V_{OUT} = 0$	1.8			
Oscillator					
Amplitude	$V_{CC} = 9 \text{ V}$	3.5	3.7	3.9	V
C_T to DRIVE high propagation delay	Overdrive = 0.2 V		100	200	ns
C_T to DRIVE low propagation delay	Overdrive = 0.2 V		50	100	
Driver					
VOL	$I = 20 \text{ mA}$, $V_{CC} = 9 \text{ V}$		0.15	0.4	V
	$I = 100 \text{ mA}$, $V_{CC} = 9 \text{ V}$		0.7	1.8	
VOH	$I = -20 \text{ mA}$, $V_{CC} = 9 \text{ V}$	8.5	8.8		
	$I = -100 \text{ mA}$, $V_{CC} = 9 \text{ V}$	6.1	7.8		
Rise time	$C_{LOAD} = 1 \text{ nF}$		35	70	ns
Fall time	$C_{LOAD} = 1 \text{ nF}$		30	60	
Line Voltage Detection					
Charge coefficient: $I_{CHG}/I(T_{ON})$	$V_{CT} = 3 \text{ V}$, DRIVE = High, $I(T_{ON}) = 1 \text{ mA}$	0.73	0.79	0.85	
Minimum line voltage for fault	$R_{ON} = 330\text{k}$	60	80	100	V
Minimum current $I(T_{ON})$ for fault	$R_{ON} = 330\text{k}$		220		μA
On time during fault	$C_T = 150 \text{ pF}$, $V_{LINE} = \text{Min} - 1 \text{ V}$		2		μs
Oscillator restart delay after fault			0.5		ms
V_{OUT} Error Amp					
V_{OUT} regulated 5 V (ADJ open)	$V_{CC} = 9 \text{ V}$, $I_{DCHG} = I(T_{OFF})/2$	4.5	5	5.5	V
Discharge ratio: $I_{DCHG} / I(T_{OFF})$	$I(T_{OFF}) = 50 \mu\text{A}$	0.9	1	1.1	
Voltage at T_{OFF}	$I(T_{OFF}) = 50 \mu\text{A}$	0.6	0.95	1.3	
Regulation gm ⁽¹⁾	Max $I_{DCHG} = 50 \mu\text{A}$		2.4		mA/V
	Max $I_{DCHG} = 125 \mu\text{A}$	1.9	4.1	7	

(1) gm is defined as

$$\frac{\Delta I_{DCHG}}{\Delta V_{OUT}}$$

for the values of V_{OUT} when V_{OUT} is in regulation. The two points used to calculate gm are for I_{DCHG} at 65% and 35% of its maximum value.

PIN DESCRIPTIONS

ADJ: The ADJ pin is used to provide a 5-V regulated supply without additional external components. Other output voltages can be obtained by connecting a resistor divider between V_{OUT} , ADJ and GND. Use the formula:

$$V_{OUT} = 2.5 \text{ V} \cdot \frac{R1+R2}{R2}$$

where R1 is connected between V_{OUT} and ADJ, and R2 is connected between ADJ and GND. $R1 \parallel R2$ should be less than 1 k Ω to minimize the effect of the temperature coefficient of the internal 30-k Ω resistors, which also connect to V_{OUT} , ADJ, and GND. See [Figure 1](#).

C_T (timing capacitor): The signal voltage at C_T has a peak-to-peak swing of 3.7 V for 9 V V_{CC} . As the voltage at C_T crosses the oscillator upper threshold, DRIVE goes low. As the voltage on C_T crosses the oscillator lower threshold, DRIVE goes high.

DRIVE: This output is a CMOS stage capable of sinking 200 mA peak and sourcing 150 mA peak. The output voltage swing is 0 to V_{CC} .

GND (chip ground): All voltages are measured with respect to GND.

T_{OFF} (regulated output control): T_{OFF} sets the discharge current of the timing capacitor through an external resistor connected between V_{OUT} and T_{OFF} .

T_{ON} (line voltage control): T_{ON} serves three functions. When C_T is discharging (off time), the current through T_{ON} is routed to V_{CC} . When C_T is charging (on time), the current through T_{ON} is split 80% to set the C_T charge time and 20% to sense minimum line voltage, which occurs for a T_{ON} current of 220 μ A. For a minimum line voltage of 80 V, R_{ON} is 330 k Ω .

The C_T voltage slightly affects the value of the charge current during the on time. During this time, the voltage at the T_{ON} pin increases from 2.5 V to 6.5 V.

V_{CC} (chip supply voltage): The supply voltage of the device at pin V_{CC} is internally clamped at 9 V. The device needs an external supply, from a source such as the rectified ac line or derived from the switching circuit. Precautions must be taken to ensure that total ICC does not exceed 8 mA.

V_{OUT} (regulated output): The V_{OUT} pin is directly connected to the power supply output voltage. When V_{OUT} is greater than V_{CC} , V_{OUT} bootstraps V_{CC} .

PIN DESCRIPTIONS (continued)

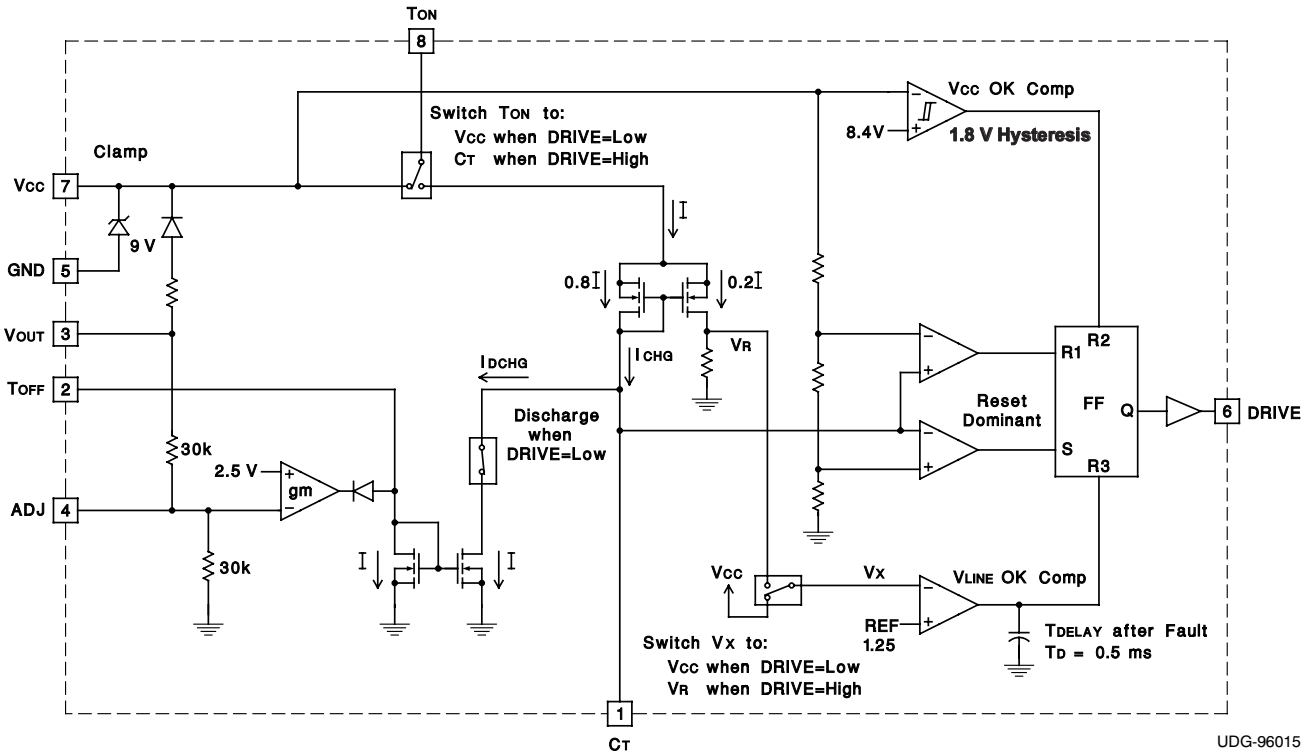

TYPICAL CHARACTERISTICS

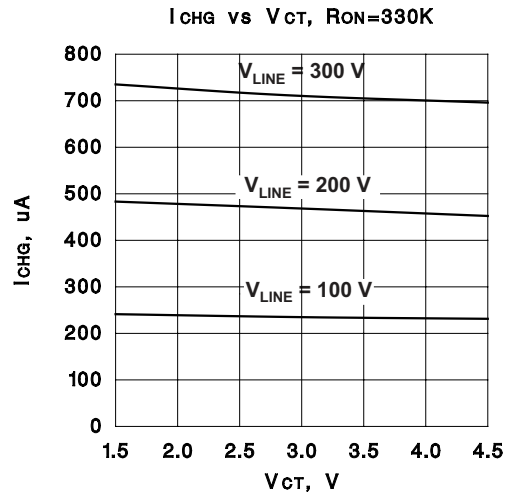
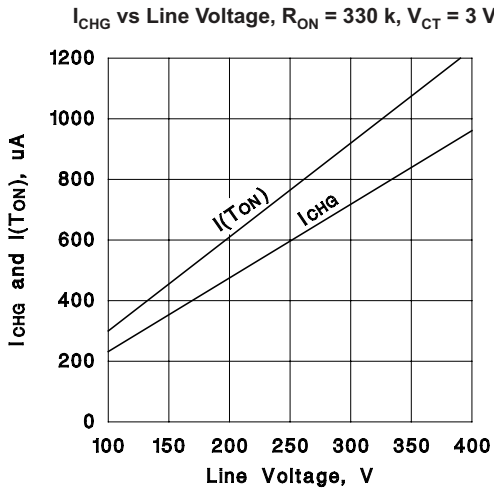

PACKAGING INFORMATION

Orderable Device	Status ⁽¹⁾	Package Type	Package Drawing	Pins	Package Qty	Eco Plan ⁽²⁾	Lead/ Ball Finish	MSL Peak Temp ⁽³⁾	Samples (Requires Login)
UCC3888D	ACTIVE	SOIC	D	8	75	Green (RoHS & no Sb/Br)	CU NIPDAU	Level-2-260C-1 YEAR	Request Free Samples
UCC3888DG4	ACTIVE	SOIC	D	8	75	Green (RoHS & no Sb/Br)	CU NIPDAU	Level-2-260C-1 YEAR	Request Free Samples
UCC3888N	ACTIVE	PDIP	P	8	50	Green (RoHS & no Sb/Br)	CU NIPDAU	N / A for Pkg Type	Request Free Samples
UCC3888NG4	ACTIVE	PDIP	P	8	50	Green (RoHS & no Sb/Br)	CU NIPDAU	N / A for Pkg Type	Request Free Samples

⁽¹⁾ The marketing status values are defined as follows:

ACTIVE: Product device recommended for new designs.

LIFEBUY: TI has announced that the device will be discontinued, and a lifetime-buy period is in effect.

NRND: Not recommended for new designs. Device is in production to support existing customers, but TI does not recommend using this part in a new design.

PREVIEW: Device has been announced but is not in production. Samples may or may not be available.

OBSELETE: TI has discontinued the production of the device.

⁽²⁾ Eco Plan - The planned eco-friendly classification: Pb-Free (RoHS), Pb-Free (RoHS Exempt), or Green (RoHS & no Sb/Br) - please check <http://www.ti.com/productcontent> for the latest availability information and additional product content details.

TBD: The Pb-Free/Green conversion plan has not been defined.

Pb-Free (RoHS): TI's terms "Lead-Free" or "Pb-Free" mean semiconductor products that are compatible with the current RoHS requirements for all 6 substances, including the requirement that lead not exceed 0.1% by weight in homogeneous materials. Where designed to be soldered at high temperatures, TI Pb-Free products are suitable for use in specified lead-free processes.

Pb-Free (RoHS Exempt): This component has a RoHS exemption for either 1) lead-based flip-chip solder bumps used between the die and package, or 2) lead-based die adhesive used between the die and leadframe. The component is otherwise considered Pb-Free (RoHS compatible) as defined above.

Green (RoHS & no Sb/Br): TI defines "Green" to mean Pb-Free (RoHS compatible), and free of Bromine (Br) and Antimony (Sb) based flame retardants (Br or Sb do not exceed 0.1% by weight in homogeneous material)

⁽³⁾ MSL, Peak Temp. -- The Moisture Sensitivity Level rating according to the JEDEC industry standard classifications, and peak solder temperature.

Important Information and Disclaimer: The information provided on this page represents TI's knowledge and belief as of the date that it is provided. TI bases its knowledge and belief on information provided by third parties, and makes no representation or warranty as to the accuracy of such information. Efforts are underway to better integrate information from third parties. TI has taken and continues to take reasonable steps to provide representative and accurate information but may not have conducted destructive testing or chemical analysis on incoming materials and chemicals. TI and TI suppliers consider certain information to be proprietary, and thus CAS numbers and other limited information may not be available for release.

In no event shall TI's liability arising out of such information exceed the total purchase price of the TI part(s) at issue in this document sold by TI to Customer on an annual basis.

P (R-PDIP-T8)

PLASTIC DUAL-IN-LINE PACKAGE





- NOTES:
- A. All linear dimensions are in inches (millimeters).
 - B. This drawing is subject to change without notice.
 - C. Falls within JEDEC MS-001 variation BA.

D (R-PDSO-G8)

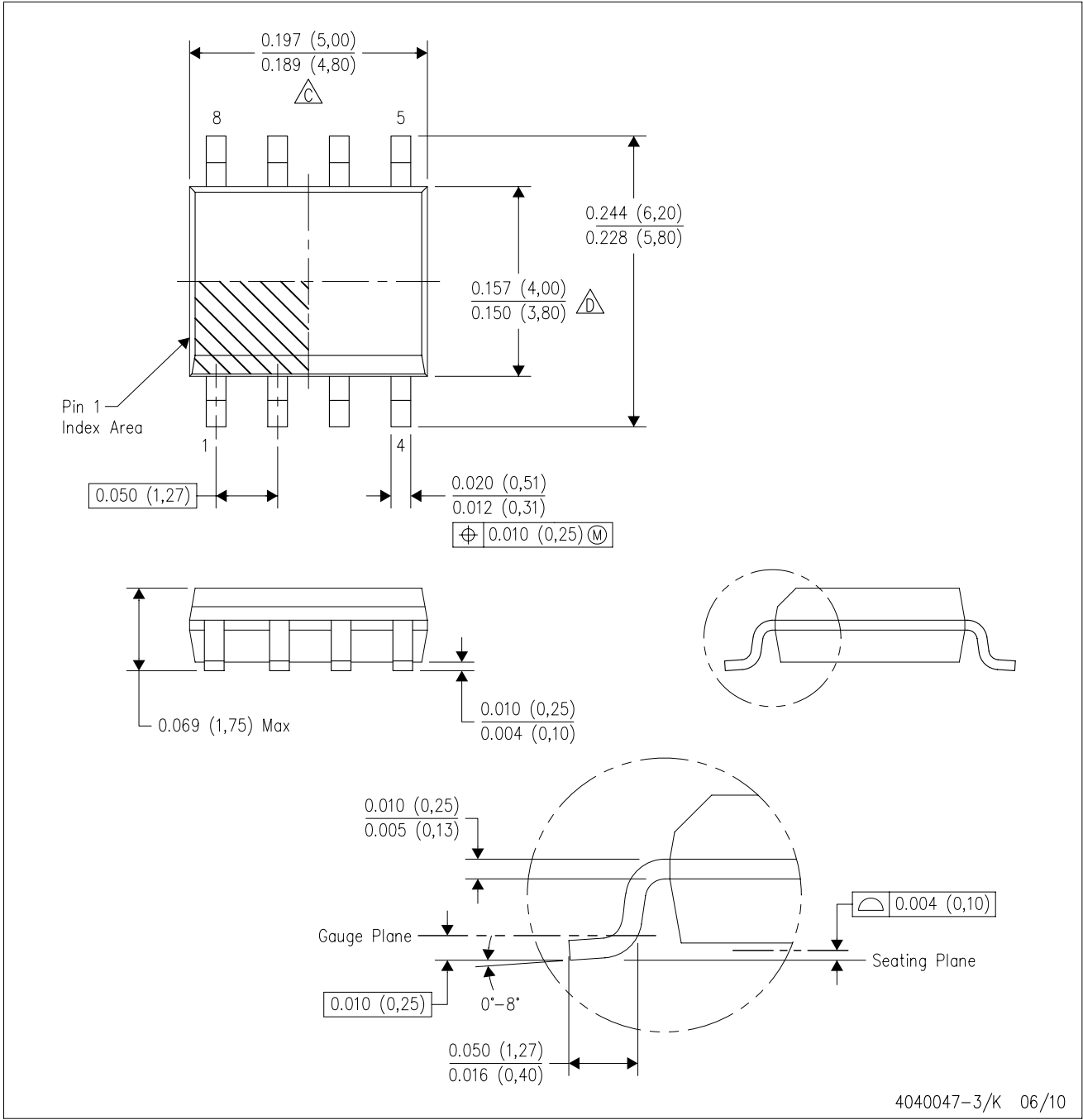
PLASTIC SMALL-OUTLINE PACKAGE



- NOTES:
- A. All linear dimensions are in inches (millimeters).
 - B. This drawing is subject to change without notice.
 -  Body length does not include mold flash, protrusions, or gate burrs. Mold flash, protrusions, or gate burrs shall not exceed .006 (0,15) per end.
 -  Body width does not include interlead flash. Interlead flash shall not exceed .017 (0,43) per side.
 - E. Reference JEDEC MS-012 variation AA.

D (R-PDSO-G8)

PLASTIC SMALL OUTLINE

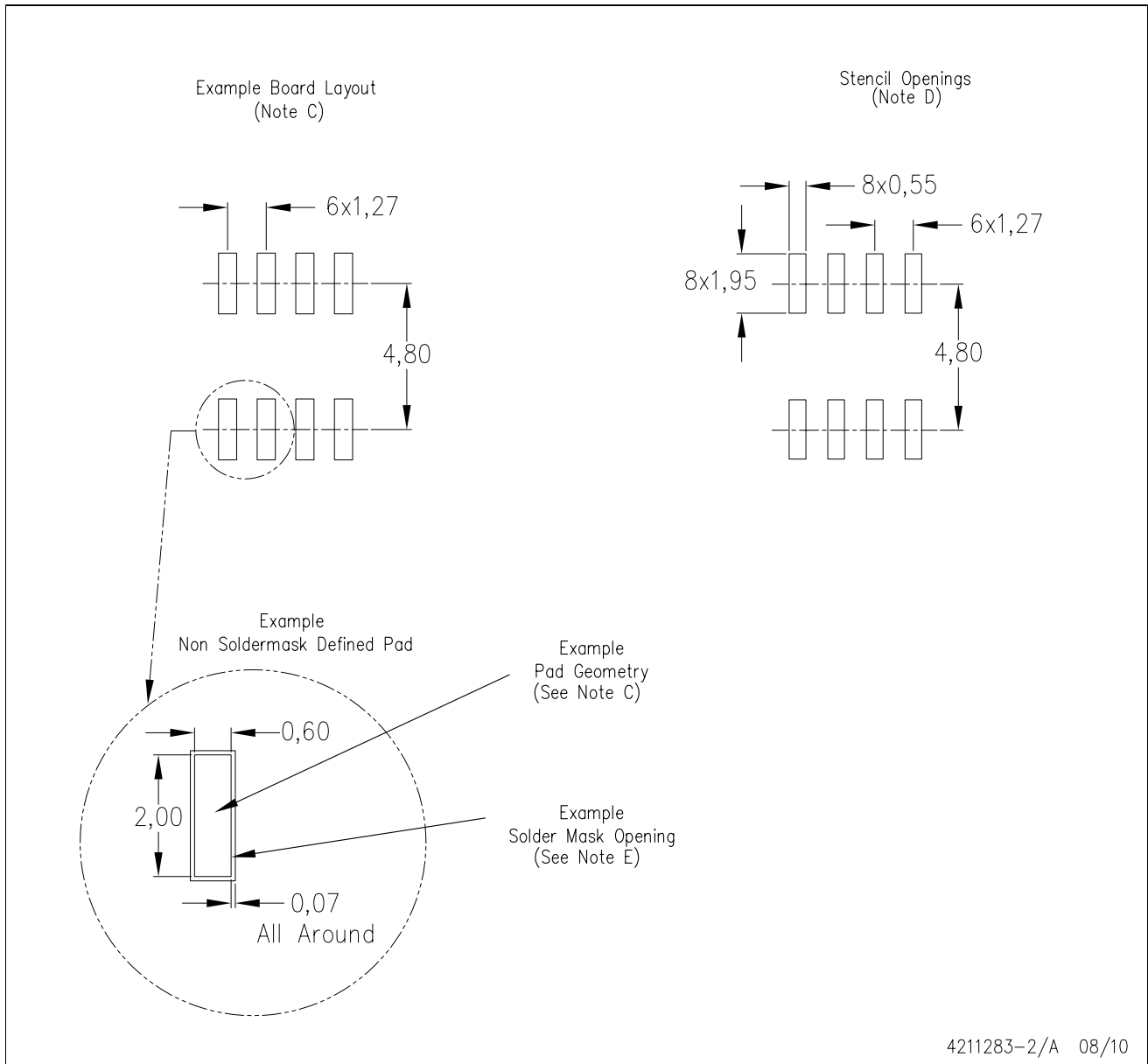

4211283-2/A 08/10

- NOTES:
- All linear dimensions are in millimeters.
 - This drawing is subject to change without notice.
 - Publication IPC-7351 is recommended for alternate designs.
 - Laser cutting apertures with trapezoidal walls and also rounding corners will offer better paste release. Customers should contact their board assembly site for stencil design recommendations. Refer to IPC-7525 for other stencil recommendations.
 - Customers should contact their board fabrication site for solder mask tolerances between and around signal pads.

IMPORTANT NOTICE

Texas Instruments Incorporated and its subsidiaries (TI) reserve the right to make corrections, modifications, enhancements, improvements, and other changes to its products and services at any time and to discontinue any product or service without notice. Customers should obtain the latest relevant information before placing orders and should verify that such information is current and complete. All products are sold subject to TI's terms and conditions of sale supplied at the time of order acknowledgment.

TI warrants performance of its hardware products to the specifications applicable at the time of sale in accordance with TI's standard warranty. Testing and other quality control techniques are used to the extent TI deems necessary to support this warranty. Except where mandated by government requirements, testing of all parameters of each product is not necessarily performed.

TI assumes no liability for applications assistance or customer product design. Customers are responsible for their products and applications using TI components. To minimize the risks associated with customer products and applications, customers should provide adequate design and operating safeguards.

TI does not warrant or represent that any license, either express or implied, is granted under any TI patent right, copyright, mask work right, or other TI intellectual property right relating to any combination, machine, or process in which TI products or services are used. Information published by TI regarding third-party products or services does not constitute a license from TI to use such products or services or a warranty or endorsement thereof. Use of such information may require a license from a third party under the patents or other intellectual property of the third party, or a license from TI under the patents or other intellectual property of TI.

Reproduction of TI information in TI data books or data sheets is permissible only if reproduction is without alteration and is accompanied by all associated warranties, conditions, limitations, and notices. Reproduction of this information with alteration is an unfair and deceptive business practice. TI is not responsible or liable for such altered documentation. Information of third parties may be subject to additional restrictions.

Resale of TI products or services with statements different from or beyond the parameters stated by TI for that product or service voids all express and any implied warranties for the associated TI product or service and is an unfair and deceptive business practice. TI is not responsible or liable for any such statements.

TI products are not authorized for use in safety-critical applications (such as life support) where a failure of the TI product would reasonably be expected to cause severe personal injury or death, unless officers of the parties have executed an agreement specifically governing such use. Buyers represent that they have all necessary expertise in the safety and regulatory ramifications of their applications, and acknowledge and agree that they are solely responsible for all legal, regulatory and safety-related requirements concerning their products and any use of TI products in such safety-critical applications, notwithstanding any applications-related information or support that may be provided by TI. Further, Buyers must fully indemnify TI and its representatives against any damages arising out of the use of TI products in such safety-critical applications.

TI products are neither designed nor intended for use in military/aerospace applications or environments unless the TI products are specifically designated by TI as military-grade or "enhanced plastic." Only products designated by TI as military-grade meet military specifications. Buyers acknowledge and agree that any such use of TI products which TI has not designated as military-grade is solely at the Buyer's risk, and that they are solely responsible for compliance with all legal and regulatory requirements in connection with such use.

TI products are neither designed nor intended for use in automotive applications or environments unless the specific TI products are designated by TI as compliant with ISO/TS 16949 requirements. Buyers acknowledge and agree that, if they use any non-designated products in automotive applications, TI will not be responsible for any failure to meet such requirements.

Following are URLs where you can obtain information on other Texas Instruments products and application solutions:

Products		Applications	
Amplifiers	amplifier.ti.com	Audio	www.ti.com/audio
Data Converters	dataconverter.ti.com	Automotive	www.ti.com/automotive
DLP® Products	www.dlp.com	Communications and Telecom	www.ti.com/communications
DSP	dsp.ti.com	Computers and Peripherals	www.ti.com/computers
Clocks and Timers	www.ti.com/clocks	Consumer Electronics	www.ti.com/consumer-apps
Interface	interface.ti.com	Energy	www.ti.com/energy
Logic	logic.ti.com	Industrial	www.ti.com/industrial
Power Mgmt	power.ti.com	Medical	www.ti.com/medical
Microcontrollers	microcontroller.ti.com	Security	www.ti.com/security
RFID	www.ti-rfid.com	Space, Avionics & Defense	www.ti.com/space-avionics-defense
RF/IF and ZigBee® Solutions	www.ti.com/lprf	Video and Imaging	www.ti.com/video
		Wireless	www.ti.com/wireless-apps