

4

3

2

1

THIS DRAWING IS UNPUBLISHED. RELEASED FOR PUBLICATION
© COPYRIGHT ALL RIGHTS RESERVED.

LOC	DIST	REVISIONS			
P	LTR	DESCRIPTION	DATE	DWN	APVD
	AD4	ECR-14-002796	26FEB2014	GK	HMR

REPLACED BY OCEAN STYLE APPLICATOR PART NUMBER 2151032-2

FOR REPLACEMENT PARTS FOR APPLICATOR 466778 REFER TO ADDITIONAL PAGE(S). SPARE PARTS KIT (IF LISTED) WILL REMAIN AVAILABLE.

THE REPLACEMENT OCEAN STYLE APPLICATOR HAS THE SAME TERMINATOR/PRESS INTERFACE AS APPLICATOR 466778

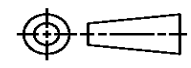
THIS DRAWING IS A CONTROLLED DOCUMENT.		DWN	GOPALAKRISHNA HV			TE Connectivity			
DIMENSIONS:		CHK	RAGHAVENDRA			NAME			
		TOLERANCES UNLESS OTHERWISE SPECIFIED:		SIDE FEED HDM APPLICATOR					
		0 PLC	±	APVD	RAGHAVENDRA		PRODUCT SPEC		
MATERIAL		1 PLC	±	APPLICATION SPEC		SIZE	CAGE CODE	DRAWING NO	RESTRICTED TO
FINISH		2 PLC	±	WEIGHT		A3		©- 466778	
		3 PLC	±	CUSTOMER ACCESSIBLE PRODUCTION DRAWING		SCALE	SHEET 1 OF 3	REV AD4	
		4 PLC	±						
		ANGLES	±						

PART NUMBER	REV	FIRST USED	POWER UNIT	FEED TYPE
466778-3	AD	854400-1	LEADMAKER	AIRFEED
466778-4	AD	565435-5	BENCH MODEL K	AIRFEED
466778-5	AD	843083-1	LEADMAKER	DOUBLE ACTING AIRFEED
466778-6	AD	354500-1	BENCH MODEL G	AIRFEED
7-466778-7	Y	-	SPARE PARTS	

GROUP I	GROUP II	AMP TERMINAL	AMP CRIMP SPECS
350815	520140		
350819	520150	PAD LTR	CRIMP HEIGHT
520106	520276	A	.075±.002
520116	521142	B	.070±.002
520124	-	C	-
-	-	D	-
		CRIMP	SIZE TYPE RANGE
		WIRE	.205 D 16-14
		INSUL	- - -

LOC	DIST	REV	DATE	BY	APPD
A	66	AD1	21FEB2007	SW	TM
		AD2	03JAN2008	MY	TE
		AD3	08JUL2009	MY	GB

- RECOMMENDED SPARE PARTS.
- GREASE LIGHTLY.
- GUARD MUST BE IN PLACE WHEN OPERATING APPLICATOR IN A BENCH MACHINE.
- SEE DRAWING FOR COMPONENTS.
- TO CHECK CRIMP HEIGHT, CRIMP SOLDER (Ø.19 60/40 SOLID CORE) AND MEASURE AT CENTER OF SLUG.

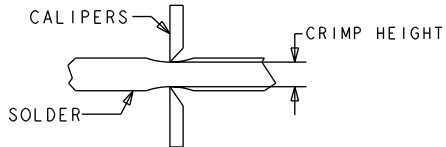

- CUT TO LENGTH AT ASSEMBLY.
- ITEM 16 MUST BE REMOVED IF APPLICATOR IS REMOVED FROM LEADMAKER AND PLACED IN AMP-O-LECTRIC* TERMINATING UNIT.
- ITEM 76 REQUIRED WHEN APPLICATOR IS REMOVED FROM LEADMAKER AND PLACED IN AMP-O-LECTRIC* TERMINATING UNIT.
- INSTALL ITEM 75 IN CHIP RELIEF HOLE OF T-TERMINATOR UNIT BEFORE INSTALLING APPLICATOR.
- REMOVE WIRE FUNNEL WHEN USING THIS APPLICATOR ON AMPOMATOR* FEED SIDE T-TERMINATOR UNIT.
- IT MAY BE NECESSARY TO MODIFY THE T-TERMINATING UNIT'S BASE PLATE BEFORE INSTALLING THIS APPLICATOR BY ADDING A 10-32 HOLE TO RELOCATE THE FORWARD STOP AS SHOWN.

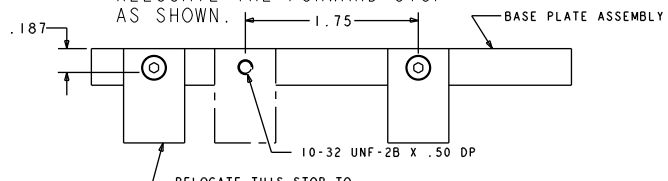

- FEED ADJUSTMENT MAY BE REQUIRED WHEN SWITCHING TERMINALS
- GROUP I: Ø.160 MAX INSULATION
GROUP II: Ø.240 MAX INSULATION.
- USE ITEMS 5 & 9 WITH GROUP I.
USE ITEMS 10 & 20 WITH GROUP II.
- AMPOMATOR* MODEL 48.
- LEADMAKER LM40 OR CS55.
- USE ITEM 46 WITH GROUP I.
USE ITEM 47 WITH GROUP II.
- ITEMS 75 AND 77 MUST BE INSTALLED IN THE G-TERMINATING UNIT CHIP RELIEF HOLE BEFORE INSTALLING THE APPLICATOR.
LEADMAKERS W/A T TERMINATING UNIT ONLY REQUIRE ITEM 75.
- ITEM NOT SHOWN.

-	1	1	1	1	-	4-21028-0	PIN, SLOTTED SPRING .094 X .750	121
-	3	3	3	3	-	21024-5	WASHER, SPRG LOCK, REG NO 10	117
-	4	4	4	4	-	21024-2	WASHER, SPRG LOCK, REG NO 4	114
-	1	1	1	1	-	21024-8	WASHER, SPRG LOCK, REG 3/8	112
-	4	4	4	4	-	21024-4	WASHER, SPRG LOCK, REG NO 8	111
-	1	1	1	1	-	22353-8	SCR, SHLD, SLOT HD, 3/16 DIA	105
-	1	1	1	1	-	21009-2	SCR, SET, SELF LOCKING 1/4-20 X .250	103
-	2	2	2	2	-	21017-2	SCREW, DRIVE	102
-	1	1	1	1	-	461264-1	PLATE, IDENTIFICATION	100
-	2	2	2	2	-	5-21006-6	SCR, SET, CUP POINT 10-32 X .750	99
-	1	1	1	1	-	22733-8	SCR, BHSC, SELF-LOCKING, 8-32 X .375	98
-	REF	REF	REF	REF	-	2-21002-9	SCR, BTN SKT HD CAP 10-32 X .750	97
-	REF	REF	REF	REF	-	2-22733-8	SCR, BHSC, SELF-LOCKING, 1/4-20 X .625	96
-	1	1	1	1	-	2-21002-7	SCR, BTN SKT HD CAP 10-32 X .500	95
-	4	4	4	4	-	2-21002-2	SCR, BTN SKT HD CAP 8-32 X .500	94
-	2	2	2	2	-	1-21000-4	SCR, SKT HD CAP 4-40 X .375	93
-	2	2	2	2	-	1-21002-7	SCR, BTN SKT HD CAP 6-32 X .375	92
-	2	2	2	2	-	1-21002-3	SCR, BTN SKT HD CAP 4-40 X .250	91
-	2	2	2	2	-	3-21000-0	SCR, SKT HD CAP 8-32 X .875	87
-	1	1	1	1	-	2-22603-1	SCREW, MACH, HEX HD, 8-32 X .375	86
-	2	2	2	2	-	1-21000-3	SCR, SKT HD CAP 4-40 X .250	85
-	1	1	1	1	-	2-21000-7	SCR, SKT HD CAP 8-32 X .500	84
-	1	1	1	1	-	3-21000-4	SCR, SKT HD CAP 10-32 X .375	81
-	-	-	-	-	-	1-18023-1	SCR, SHC, M4x10	80
-	-	-	-	-	-	462992-5	GUARD ASSY	79
-	REF	-	-	-	-	679532-1	INSERT, GUARD	78
-	-	-	-	-	-	189728-1	BRACKET, SPACER	77
-	-	REF	1	-	-	803931-1	BRACKET, HOLD DOWN	76
-	-	-	-	-	-	568681-1	SPACER, BASE PLATE	75
-	1	1	1	1	-	690603-1	SPRING ASSIST AMP-O-MATOR APPLICATOR	74
-	1	1	1	1	-	23030-1	SCR, SKT HD CAP, S-LOCK, 6-32 X .25	73
-	1	1	1	1	-	3-21001-5	SCR, SKT HD CAP 3/8-16 X 1.000	72
-	1	1	1	1	-	459610-3	MOUNT, FEED BRACKET	71
-	-	-	-	-	-	692655-5	AIR FEED VALVE ASSEMBLY	69

-	-	-	-	-	-	461065-4	AIR FEED ASSY	68
-	-	-	REF	-	-	24042-2	VALVE, SHUT-OFF	67
-	-	-	REF	-	-	692655-6	AIR FEED VALVE ASSEMBLY	66
-	1	1	1	1	-	461065-1	ASSEMBLY, AIR FEED	65
-	2	2	2	2	-	3-21000-9	SCR, SKT HD CAP 10-32 X 1.000	64
-	REF	REF	REF	REF	-	454220-1	CAP, RAM	59
-	REF	REF	REF	REF	-	454485-1	HOUSING, APPL CSTG	58
-	1	1	1	1	-	462427-1	FINGER, FEED	56
-	1	1	1	1	-	692655-7	AIR FEED VALVE ASSEMBLY	55
-	1	1	1	1	-	461062-2	FEED FINGER ASSEMBLY	53
-	-	-	-	-	-	816187-2	APPLICATOR, BASIC SUBASSEMBLY	51
-	1	1	1	1	-	816187-1	APPLICATOR, BASIC SUBASSEMBLY	50
-	1	1	1	1	-	469366-2	PLATE, REAR SHEAR	49
-	1	1	1	1	-	467590-1	HOLDER, SHEAR	48
-	1	1	1	1	-	462433-3	SUPPORT, INSULATION	47
-	1	1	1	1	-	462433-1	SUPPORT, INSULATION	46
-	1	1	1	1	-	690191-1	PLUG, NYLON	45
-	1	1	1	1	-	455673-1	RAM, SIDE FEED	44
-	1	1	1	1	-	690125-1	SHIM SUB-ASSY	43
-	1	1	1	1	-	690124-1	WASHER, RAM (.115)	42
-	1	1	1	1	-	690686-2	CRIMPER, BOLT SPECIAL	41
-	1	1	1	1	-	23241-6	BALL, STEEL	40
-	1	1	1	1	-	690170-1	SPRING, COMPRESSION	39
-	1	1	1	1	-	462426-1	DISC, SPRING	38
-	1	1	1	1	-	462425-1	WIRE DISC	37
-	8	8	8	8	-	2-22280-5	SPRING, COMPRESSION	36
-	1	1	1	1	-	690212-1	POST, RAM	35
-	-	REF	-	REF	-	808835-1	PLATE, BASE	34
-	REF	-	REF	-	-	455675-3	PLATE, BASE	33
-	1	1	1	1	-	690432-3	ADJUSTMENT SCREW	32
-	1	1	1	1	-	22480-5	WASHER, WAVE SPRING	31
-	1	1	1	1	-	455689-1	BLOCK, STRIP GUIDE ADJUST	30
-	1	1	1	1	-	684045-2	PLATE, STRIP GUIDE	29
-	2	2	2	2	-	22281-9	SPRING, COMPRESSION	27
-	1	1	1	1	-	240793-4	LEVER, DRAG RELEASE	26
-	1	1	1	1	-	240792-6	DRAG, TERMINAL	25
-	1	1	1	1	-	690438-1	FRONT STRIP GUIDE	24
-	1	1	1	1	-	684042-2	GUIDE, STRIP, FRONT	23
-	2	2	2	2	-	5-22278-1	SPRING, COMPRESSION	21
-	-	-	-	-	-	462431-5	FUNNEL, WIRE	20
-	1	1	1	1	-	690472-2	STRIPPER	19
-	1	1	1	1	-	463460-3	HOLD DOWN, TERMINAL	18
-	-	-	-	-	-	803925-1	GUIDE, CARRIER SCRAP	16
-	-	-	-	-	-	803926-1	PLATE, REAR SHEAR	15
-	-	-	-	-	-	467590-2	HOLDER, SHEAR, REAR	14
-	1	1	1	1	-	469542-3	REAR FLOATING SHEAR	13
-	1	1	1	1	-	3-22280-3	SPRING, COMPRESSION	12
-	1	1	1	1	-	1-690461-1	STOP, SHEAR	11
-	-	-	-	-	-	462843-3	TERMINAL SUPPORT	10
-	-	-	-	-	-	462843-1	TERMINAL SUPPORT	9
1	1	1	1	1	-	464282-1	ANVIL, SAND-BLASTED 16-14	8
-	1	1	1	1	-	240641-6	SPACER	7
-	1	1	1	1	-	690468-6	DEPRESSOR SHEAR, REAR	6
-	-	-	-	-	-	462431-4	WIRE FUNNEL	5
-	1	1	1	1	-	238009-3	BLOCK, FL CRIMPER SPACER	4
1	1	1	1	1	-	462432-4	STABILIZER	3
-	1	1	1	1	-	462842-1	SPACER	2
1	1	1	1	1	-	464281-1	CRIMPER, SEMI FLAT 16-14	1

THIS DRAWING IS THE PROPERTY OF TYCO ELECTRONICS CORPORATION. IT IS TO BE USED ONLY FOR THE INTENTED APPLICATION AND IS NOT TO BE REPRODUCED OR TRANSMITTED IN ANY FORM OR BY ANY MEANS, ELECTRONIC OR MECHANICAL, INCLUDING PHOTOCOPYING, RECORDING, OR BY ANY INFORMATION STORAGE AND RETRIEVAL SYSTEM.

APPROVED: T. ELBIN 22JAN2007
 DRAWN: B. WEAVER 22JAN2007
 CHECKED: T. ELBIN 22JAN2007

TYCO Electronics
 Harrisburg, PA 17105-3608

PRODUCT SPEC: SIDE FEED HDM APPLICATOR

SCALE: 1:5 SHEET 1 OF 2

CUSTOMER VIEWABLE ASSEMBLY

REVISONS		DATE	OWN	APPD
P	LYR			
SEE SHEET 1				

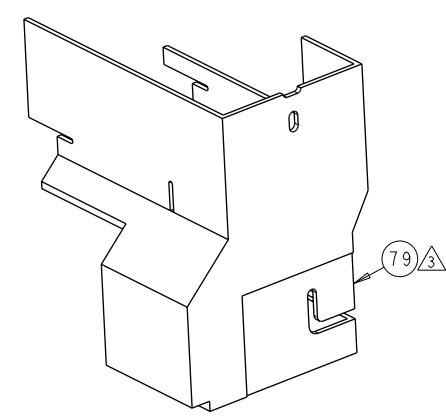
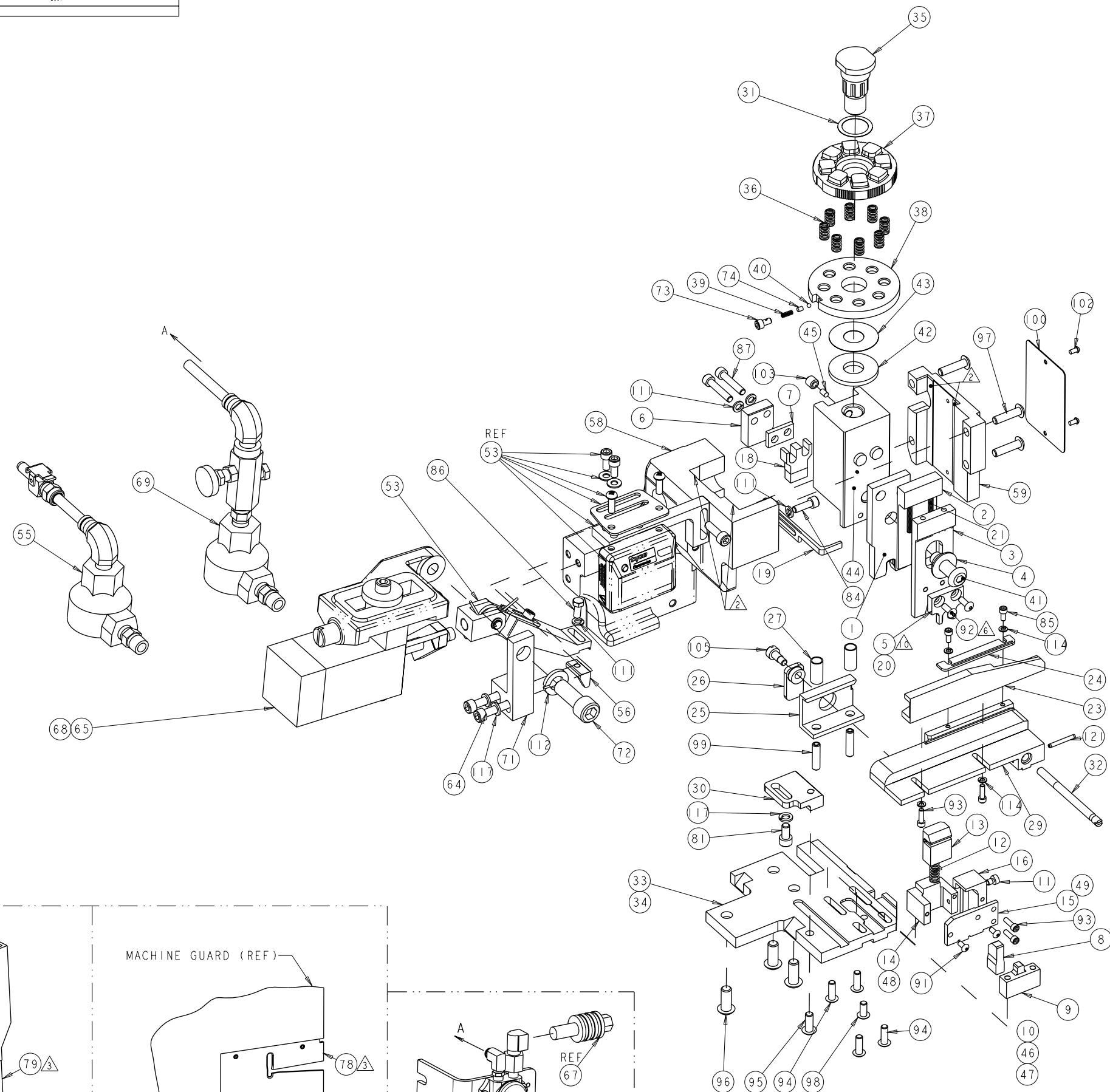

AMP-O-LETRIC* TERMINATOR GUARD

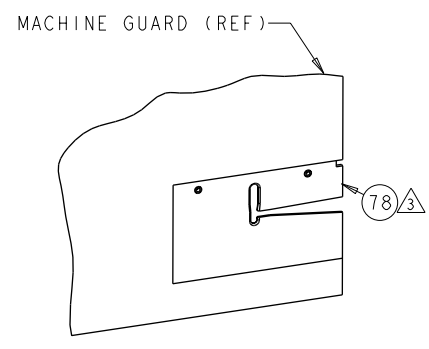

MACHINE GUARD (REF)
 G TERMINATOR GUARD

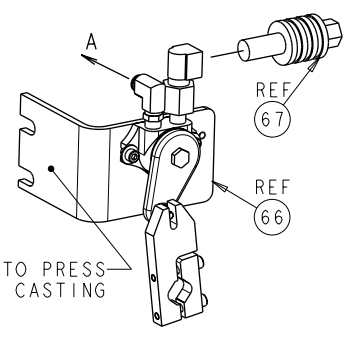

TO PRESS CASTING
 REF 67
 REF 66

DIMENSIONS:		TOLERANCES UNLESS OTHERWISE SPECIFIED:		OWN	22JAN2007	Tyco Electronics Harrisburg, PA 17105-3608
IN		0 PLC ±.015		DESIGN	B. WEAVER	
1 PLC ±.010		1 PLC ±.010		CHK	T. ELBIN	NAME SIDE FEED HDM APPLICATOR
2 PLC ±.008		2 PLC ±.008		APPD	T. ELBIN	
3 PLC ±.005		3 PLC ±.005		PRODUCT SPEC		SIZE CAGE CODE DRAWING NO RESTRICTED TO
4 PLC ±.003		4 PLC ±.003		APPLICATION SPEC		
ANGLES		FINISH		WEIGHT		A 00779 C=466778
MATERIAL		CUSTOMER DRAWING		SCALE		3:4 SHEET 2 OF 2 REV AD3

CUSTOMER VIEWABLE ASSEMBLY