

LT3942

36V, 2A Synchronous Buck-Boost Converter and LED Driver

DESCRIPTION

Demonstration circuit 2404A is a 36V synchronous buck-boost LED driver featuring the LT[®]3942. It drives a single string of LEDs up to 14V at 1A when V_{IN} is between 9V and 36V and will run down to $3V_{IN}$ with reduced I_{LED} . DC2404A runs at 2MHz switching frequency with spread spectrum frequency modulation (SSFM) disabled. When enabled, SSFM spreads the switching frequency of the LT3942 from f_{SW} to $f_{SW} + 25\%$ for reduced EMI performance.

The LT3942 has an operating input voltage range of 3V to 36V. It has internal, synchronous 40V switches for high efficiency and small size. It has an adjustable switching frequency between 300kHz and 2MHz. The LT3942 can be synchronized to an external source, programmed with SSFM enabled for low EMI, or set to normal operation.

The LT3942's integrated PWMTG high-side PWM MOSFET driver assists with short-circuit protection of the output, as well as PWM dimming of the connected LEDs. The LED string can be PWM dimmed with an external PWM signal or can be dimmed using the internally generated PWM signal. DC2404A has jumpers that can be set to switch between internally and externally generated PWM signals. The external PWM setting defaults to 100% on with no PWM signal applied. The LT3942 can also be analog dimmed by placing a controllable DC voltage on the CTRL pin.

When running PWM dimming with SSFM enabled, the SSFM aligns itself with the PWM signal for flicker free operation. This applies to both internal and external PWM dimming.

Small ceramic input and output capacitors are used to save space and cost. The board is designed with tiny, high frequency capacitors placed near the PV_{IN} and PV_{OUT} pins for a reduction in radiated EMI. The open LED overvoltage protection uses the IC's constant voltage regulation loop to regulate the output to approximately 17V peak if the LED string is opened. The output current can be monitored through the ISMON output pin.

Undervoltage lockout can be adjusted on DC2404A with a few simple resistor choices.

There is a small ferrite bead EMI filter on the input and output of DC2404A. These filters, combined with proper board layout and SSFM, are effective in reducing EMI. Please follow the recommended layout and four-layer PCB thickness of DC2404A for low EMI applications.

The LT3942 can operate as a constant current LED driver as well as a constant voltage regulator. Small changes to the circuit allow for constant output voltage regulation.

The LT3942 data sheet gives a complete description of the part, operation, and applications information. The data sheet must be read in conjunction with this demo manual for demonstration circuit 2404A. The LT3942EUFD is assembled in a 28-lead plastic QFN (UFD) package with a thermally enhanced exposed ground pad. Proper board layout is essential for maximum thermal performance. See the data sheet section Layout Considerations.

[Design files for this circuit board are available.](#)

All registered trademarks and trademarks are the property of their respective owners.

DEMO MANUAL DC2404A

PERFORMANCE SUMMARY Specifications are at $T_A = 25^\circ\text{C}$

PARAMETER	CONDITION	MIN	TYP	MAX	UNIT
Input Voltage PV_{IN} Range	Operating	3		36	V
Switching Frequency (f_{SW})	R4 = 14.3k, JP2 = NO SSFM/SYNC		2		MHz
Spread Spectrum (SSFM) Range	JP2 = SSFM ON	f_{SW}		$f_{SW} \cdot 1.25$	
I_{LED}	R1 = 0.1 Ω , 9.0V < PV_{IN} < 36V, V_{LED} = 13V		1		A
Open LED Voltage V_{OUT} (OVP)	R2 = 1M, R3 = 64.9k		17		V
Typical Efficiency	PV_{IN} = 13V, V_{LED} = 13V, I_{LED} = 1A, FB1 and FB2 Shorted		90		%
Internally Generated PWM Dimming Frequency	JP1 = ON, JP3 = INT, R6 = 332k, R4 = 14.3k		122		Hz
Peak Switch Current Limit		2.2	2.5	2.8	A
PV_{IN} Undervoltage Lockout (UVLO) Falling	R7 = 402k, R12 = 324k		3		V
PV_{IN} Enable Turn-On (EN) Rising	R7 = 402k, R12 = 324k		4		V
PV_{IN} Overvoltage Lockout (OVLO) Rising	R11 = 1M, R10 = 34.8k		36		V

QUICK START PROCEDURE

Demonstration circuit 2404A is easy to set up to evaluate the performance of the LT3942. Follow the procedure below:

1. With power off, connect a string of LEDs that will run with forward voltage less than or equal to 14V (at 1A) to the LED+ and LED- turrets on the PCB as shown in Figure 1.
2. Connect the EN/UVLO turret to GND.
3. Set JP3 to EXT/ON and JP1 to OFF for 100% always on LED operation. Set JP2 to NO SSFM/SYNC to run without SSFM.
4. With power off, connect the input power supply to the PV_{IN} and GND turrets. Make sure that the DC input voltage will not exceed 40V.
5. Turn the input power supply on and make sure the voltage is between 9V and 36V for proper operation at max LED current.
6. Release the EN/UVLO-to-GND connection.
7. Observe the LED string running at the programmed LED current.
8. To change the brightness with analog dimming, simply attach a voltage source to the CTRL turret and set the voltage between 0V and 1.5V. See data sheet for details.
9. To change the brightness with external PWM dimming, set JP3 to EXT/ON and JP1 to OFF. Attach a 3V rectangular waveform with varying duty cycle to the PWM terminal.
10. To change the brightness with internally generated PWM dimming, set JP3 to INT and JP1 to ON. Adjust the setting of the VR1 variable resistor with a small flathead screwdriver to toggle between 0% and 100% PWM dimming duty cycle in 1/128 steps.
11. To enable spread spectrum frequency modulation, set JP2 to SSFM ON.

QUICK START PROCEDURE

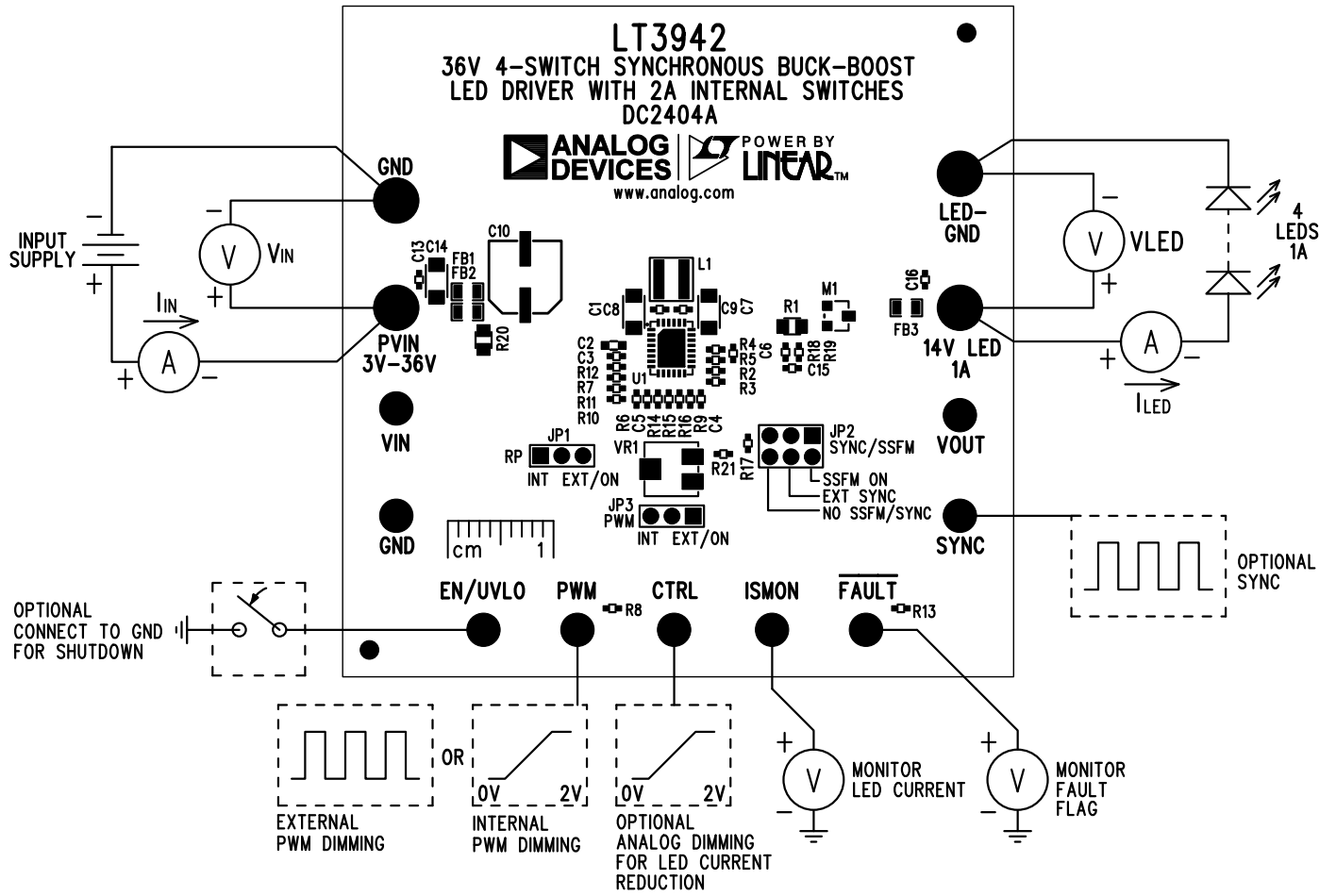

Figure 1. Test Procedure Setup Drawing for DC2404A

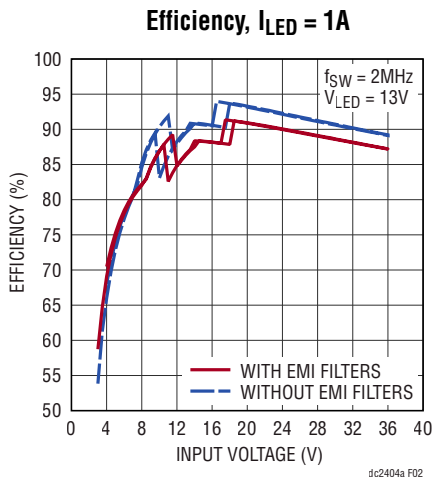

Figure 2. DC2404 Efficiency Versus Input Voltage for 13V 1A LED Load

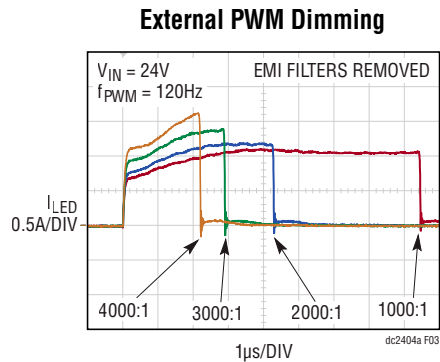

Figure 3. External PWM Dimming Performance with EMI Filters Removed

DEMO MANUAL DC2404A

PARTS LIST

ITEM	QTY	REFERENCE	PART DESCRIPTION	MANUFACTURER/PART NUMBER
Required Circuit Components				
1	1	C1	CAP, CER., 10 μ F, X5R, 50V, 10%, 1206	TAIYO YUDEN, UMK316BBJ106KL-T
2	1	C2	CAP, CER., 0.47 μ F, X7R, 50V, 10%, 0603	TDK, C1608X7R1H474K080AC
3	1	C3	CAP, CER., 2.2 μ F, X5R, 10V, 10%, 0402	MURATA, GRM155R61A225KE95D
4	1	C4	CAP, CER., 0.1 μ F, X7R, 16V, 10%, 0402	MURATA, GCM155R71C104KA55D
5	1	C5	CAP, CER., 0.22 μ F, X5R, 10V, 10%, 0402	TDK, CGA2B3X5R1A224M050BB
6	1	C6	CAP, CER., 3.3nF, C0G, 50V, 5%, 0402	MURATA, GRM1555C1H332JE01
7	1	C7	CAP, CER., 4.7 μ F, X7R 25V, 10%, 1206	MURATA, GRM31CR71E475KA88L
8	2	C8, C9	CAP, CER., 0.1 μ F, X7R, 10V, 10%, 0402	MURATA, GRM155R71A104KA01D
9	1	L1	IND., 3.3 μ H, 4020	WURTH ELEKTRONIK, 74438356033
10	1	M1	P-MOSFET, 20V, 5.9A, SOT23	VISHAY, Si2365EDS-T1-GE3
11	1	R1	RES, SENSE, 0.1 Ω , 1/2W, 1%, 0805	SUSUMU, KRL1220E-M-R100-F-T5
12	2	R2, R11	RES, CHIP, 1M, 1/16W, 5%, 0402	VISHAY, CRCW04021M00JNED
13	1	R3	RES, CHIP, 64.9k, 1/16W, 1%, 0402	VISHAY, CRCW040264K9FKED
14	1	R4	RES, CHIP, 14.3k, 1/16W, 1%, 0402	VISHAY, CRCW040214K3FKED
15	1	R5	RES, CHIP, 3.9k, 1/10W, 5%, 0402	VISHAY, CRCW04023K90JNED
16	1	R7	RES, CHIP, 402k, 1/10W, 1%, 0402	VISHAY, CRCW0402402KFKED
17	1	R10	RES, CHIP, 34.8k, 1/10W, 1%, 0402	VISHAY, CRCW040234K8FKED
18	1	R12	RES, CHIP, 324k, 1/16W, 1%, 0402	VISHAY, CRCW0402324KFKED
19	1	U1	I.C., LT3942, 28QFN-4X5	ANALOG DEVICES INC., LT3942EUFD#PBF
Additional Demo Board Circuit Components				
20	1	C10	CAP, ALUM., 33 μ F, 50V, 20%, 6.3X7.7mm	SUNCON, 50CE33FS
21	1	C13	CAP, CER., 0.1 μ F, X5R, 50V, 10%, 0402	TAIYO YUDEN, UMK105BJ104KV-F
22	1	C14	CAP, CER., 10 μ F, X5R, 50V, 10%, 1206	TAIYO YUDEN, UMK316BBJ106KL-T
23	0	C15 (OPT)	CAP, OPTION, 0402	
24	1	C16	CAP, CER., 0.1 μ F, X7R, 25V, 10%, 0402	AVX, 04023C104KAT2A
25	3	FB1, FB2, FB3	FERRITE, BEAD, 1k, 0805	TDK, MPZ2012S102ATD25
26	1	R6	RES, CHIP, 332k, 1/16W, 1%, 0402	VISHAY, CRCW0402332KFKED
27	3	R8, R13, R14	RES, CHIP, 100k, 1/16W, 5%, 0402	VISHAY, CRCW0402100KJNED
28	0	R9, R15, R16, R17, R18, R19 (OPT)	RES., OPTION, 0402	
29	0	R20 (OPT)	RES., OPTION, 0805	
30	1	R21	RES, CHIP, 91k, 1/16W, 1%, 0402	VISHAY, CRCW040291K0FKED
31	1	VR1	TRIMMER., 100k, 0.25W, SMD	BOURNS, 3314J-1-104E
Hardware: For Demo Board Only				
32	9	E1, E4-E9, E12, E13	TESTPOINT, TURRET, 0.061" MTH HOLE	MILL-MAX, 2308-2-00-80-00-00-07-0
33	4	E2, E3, E10, E11	TESTPOINT, TURRET, 0.094" MTH HOLE	MILL-MAX, 2501-2-00-80-00-00-07-0
34	2	JP1, JP3	CONN., HEADER, 1X3, 2mm	WURTH ELEKTRONIK, 62000311121
35	1	JP2	CONN., HEADER, 2X3, 2mm	WURTH ELEKTRONIK, 62000621121
36	3	XJP1, XJP2, XJP3	SHUNT, 0.079" CENTER	WURTH ELEKTRONIK, 60800213421

SCHEMATIC DIAGRAM

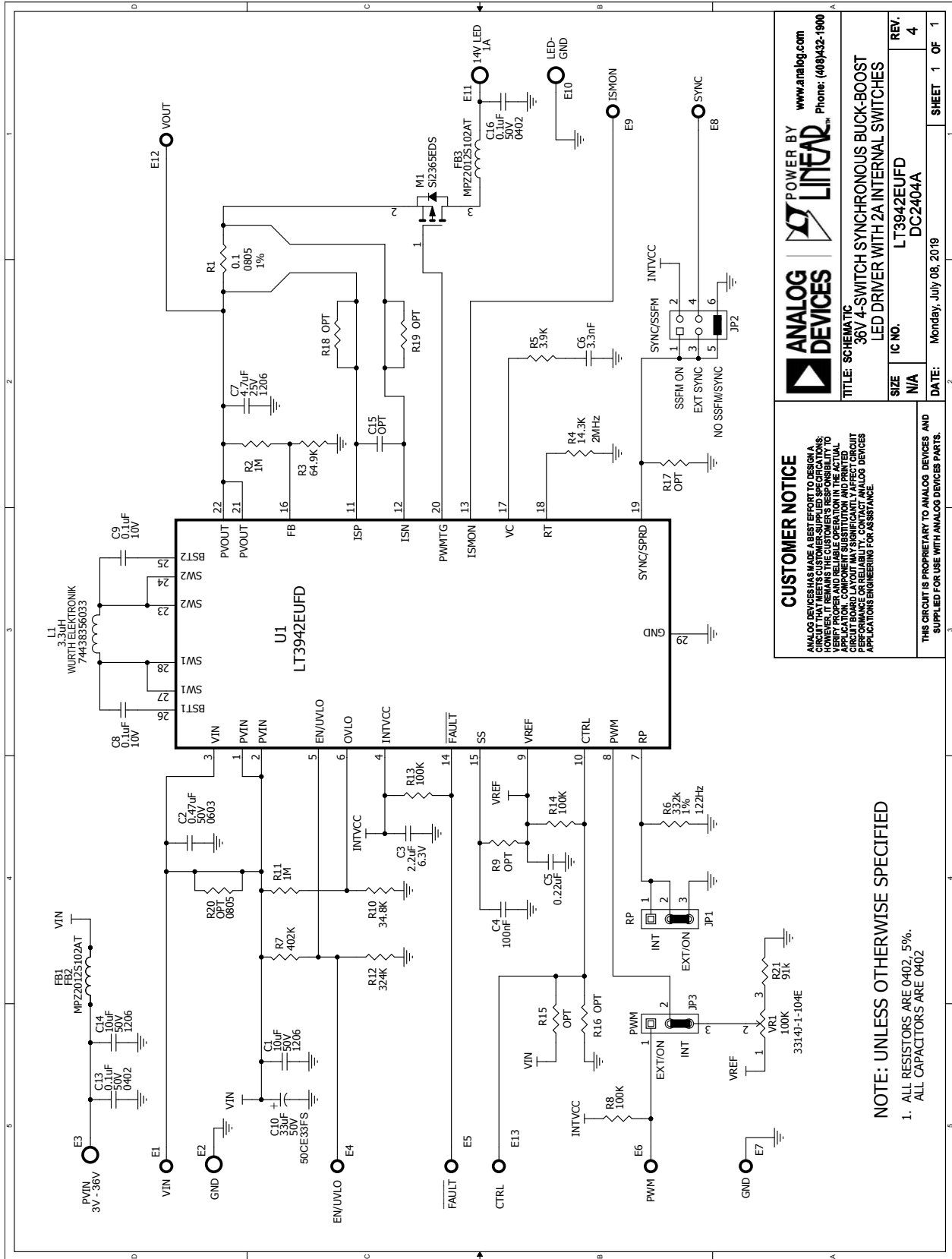

CUSTOMER NOTICE
 ANALOG DEVICES HAS MADE A BEST EFFORT TO DESIGN A CIRCUIT THAT MEETS CUSTOMER'S SUPPLIED SPECIFICATIONS. HOWEVER, IT REMAINS THE CUSTOMER'S RESPONSIBILITY TO VERIFY PROPER AND RELIABLE OPERATION IN THE ACTUAL APPLICATION. THE SCHEMATIC AND BOARD LAYOUT MAY SIGNIFICANTLY AFFECT CIRCUIT PERFORMANCE OR RELIABILITY. CONTACT ANALOG DEVICES APPLICATIONS ENGINEERING FOR ASSISTANCE.

THIS CIRCUIT IS PROPRIETARY TO ANALOG DEVICES AND SUPPLIED FOR USE WITH ANALOG DEVICES PARTS.

ANALOG DEVICES | POWER BY **LINEAR** | www.analog.com
 Phone: (609)432-1900

TITLE: SCHEMATIC
36V 4-SWITCH SYNCHRONOUS BUCK-BOOST LED DRIVER WITH 2A INTERNAL SWITCHES

SIZE	N/A	IC NO.	LT3942EUFD	REV.	4
DATE:	Monday, July 08, 2019		DC2404A	SHEET	1 OF 1

NOTE: UNLESS OTHERWISE SPECIFIED
 1. ALL RESISTORS ARE 0402, 5%.
 ALL CAPACITORS ARE 0402



ESD Caution

ESD (electrostatic discharge) sensitive device. Charged devices and circuit boards can discharge without detection. Although this product features patented or proprietary protection circuitry, damage may occur on devices subjected to high energy ESD. Therefore, proper ESD precautions should be taken to avoid performance degradation or loss of functionality.

Legal Terms and Conditions

By using the evaluation board discussed herein (together with any tools, components documentation or support materials, the "Evaluation Board"), you are agreeing to be bound by the terms and conditions set forth below ("Agreement") unless you have purchased the Evaluation Board, in which case the Analog Devices Standard Terms and Conditions of Sale shall govern. Do not use the Evaluation Board until you have read and agreed to the Agreement. Your use of the Evaluation Board shall signify your acceptance of the Agreement. This Agreement is made by and between you ("Customer") and Analog Devices, Inc. ("ADI"), with its principal place of business at One Technology Way, Norwood, MA 02062, USA. Subject to the terms and conditions of the Agreement, ADI hereby grants to Customer a free, limited, personal, temporary, non-exclusive, non-sublicensable, non-transferable license to use the Evaluation Board FOR EVALUATION PURPOSES ONLY. Customer understands and agrees that the Evaluation Board is provided for the sole and exclusive purpose referenced above, and agrees not to use the Evaluation Board for any other purpose. Furthermore, the license granted is expressly made subject to the following additional limitations: Customer shall not (i) rent, lease, display, sell, transfer, assign, sublicense, or distribute the Evaluation Board; and (ii) permit any Third Party to access the Evaluation Board. As used herein, the term "Third Party" includes any entity other than ADI, Customer, their employees, affiliates and in-house consultants. The Evaluation Board is NOT sold to Customer; all rights not expressly granted herein, including ownership of the Evaluation Board, are reserved by ADI. CONFIDENTIALITY. This Agreement and the Evaluation Board shall all be considered the confidential and proprietary information of ADI. Customer may not disclose or transfer any portion of the Evaluation Board to any other party for any reason. Upon discontinuation of use of the Evaluation Board or termination of this Agreement, Customer agrees to promptly return the Evaluation Board to ADI. ADDITIONAL RESTRICTIONS. Customer may not disassemble, decompile or reverse engineer chips on the Evaluation Board. Customer shall inform ADI of any occurred damages or any modifications or alterations it makes to the Evaluation Board, including but not limited to soldering or any other activity that affects the material content of the Evaluation Board. Modifications to the Evaluation Board must comply with applicable law, including but not limited to the RoHS Directive. TERMINATION. ADI may terminate this Agreement at any time upon giving written notice to Customer. Customer agrees to return to ADI the Evaluation Board at that time. LIMITATION OF LIABILITY. THE EVALUATION BOARD PROVIDED HEREUNDER IS PROVIDED "AS IS" AND ADI MAKES NO WARRANTIES OR REPRESENTATIONS OF ANY KIND WITH RESPECT TO IT. ADI SPECIFICALLY DISCLAIMS ANY REPRESENTATIONS, ENDORSEMENTS, GUARANTEES, OR WARRANTIES, EXPRESS OR IMPLIED, RELATED TO THE EVALUATION BOARD INCLUDING, BUT NOT LIMITED TO, THE IMPLIED WARRANTY OF MERCHANTABILITY, TITLE, FITNESS FOR A PARTICULAR PURPOSE OR NON-INFRINGEMENT OF INTELLECTUAL PROPERTY RIGHTS. IN NO EVENT WILL ADI AND ITS LICENSORS BE LIABLE FOR ANY INCIDENTAL, SPECIAL, INDIRECT, OR CONSEQUENTIAL DAMAGES RESULTING FROM CUSTOMER'S POSSESSION OR USE OF THE EVALUATION BOARD, INCLUDING BUT NOT LIMITED TO LOST PROFITS, DELAY COSTS, LABOR COSTS OR LOSS OF GOODWILL. ADI'S TOTAL LIABILITY FROM ANY AND ALL CAUSES SHALL BE LIMITED TO THE AMOUNT OF ONE HUNDRED US DOLLARS (\$100.00). EXPORT. Customer agrees that it will not directly or indirectly export the Evaluation Board to another country, and that it will comply with all applicable United States federal laws and regulations relating to exports. GOVERNING LAW. This Agreement shall be governed by and construed in accordance with the substantive laws of the Commonwealth of Massachusetts (excluding conflict of law rules). Any legal action regarding this Agreement will be heard in the state or federal courts having jurisdiction in Suffolk County, Massachusetts, and Customer hereby submits to the personal jurisdiction and venue of such courts. The United Nations Convention on Contracts for the International Sale of Goods shall not apply to this Agreement and is expressly disclaimed.