

THIS DRAWING IS UNPUBLISHED. RELEASED FOR PUBLICATION  
 © COPYRIGHT - By - ALL RIGHTS RESERVED.

LOC		DIST		REVISIONS			
P	LTR	DESCRIPTION		DATE	DWN	APVD	
AF	50	D		REVISED PER ECR-13-011489	16DEC2013	KH	PD

SUGGESTED MATING TAB

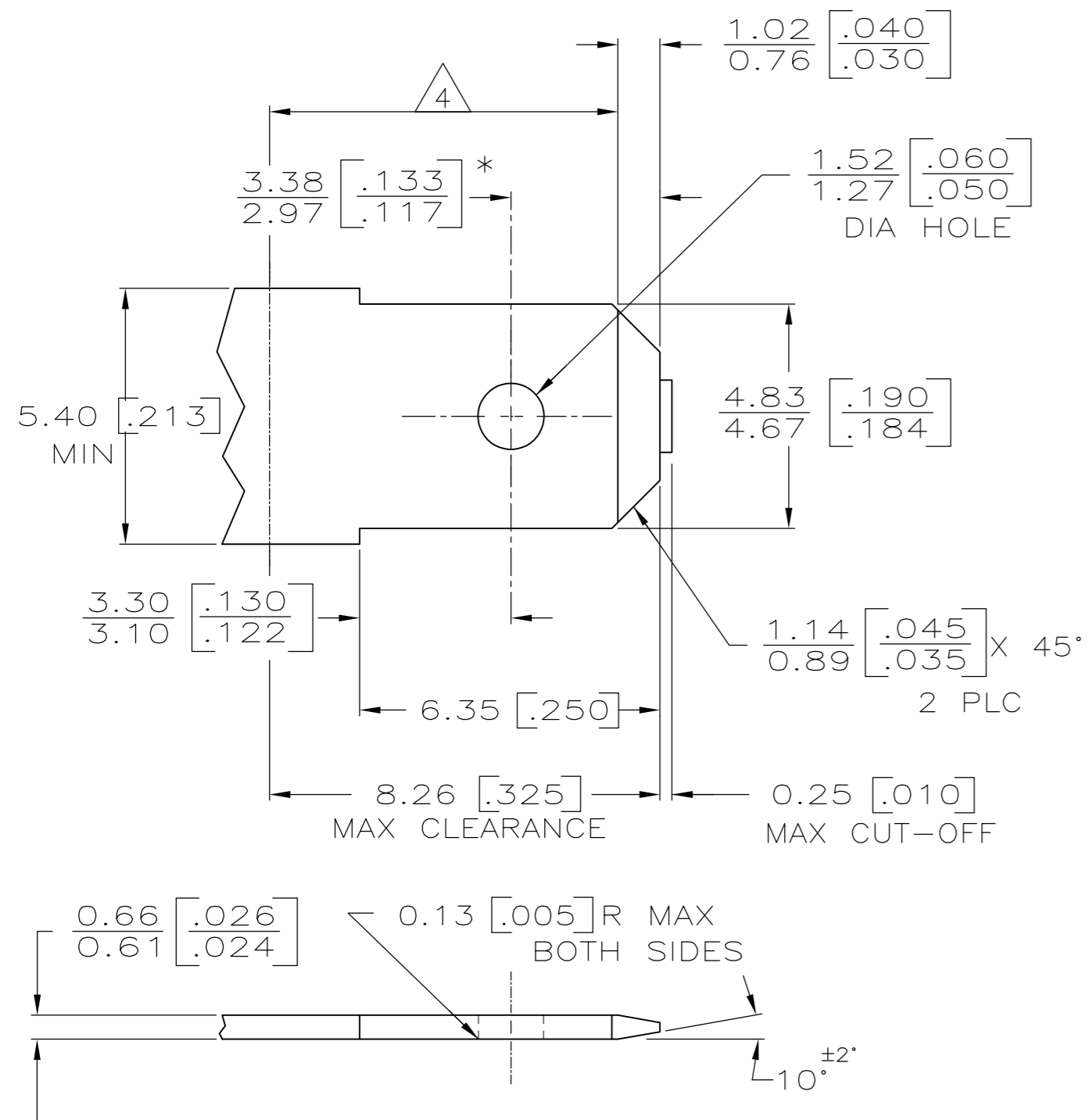

- 1 MATL: #2 HARD BRASS OR NICKEL PLATED STEEL.
  - 2 NO BURRS PERMISSIBLE AT HOLE.
  - 3 TIN PLATING IS REQUIRED ON BRASS WHEN TERMINAL TEMPERATURE IS OVER 225° F.
  - 4 MUST BE FLAT WITHIN 0.076[.003] OVER THIS LENGTH.
  - 5 HOLE MUST BE SYMMETRICAL ABOUT TAB  $\pm$  WITHIN 0.076[.003].
- \* TO BE USED ONLY WHEN SHOULDER IS ELIMINATED.

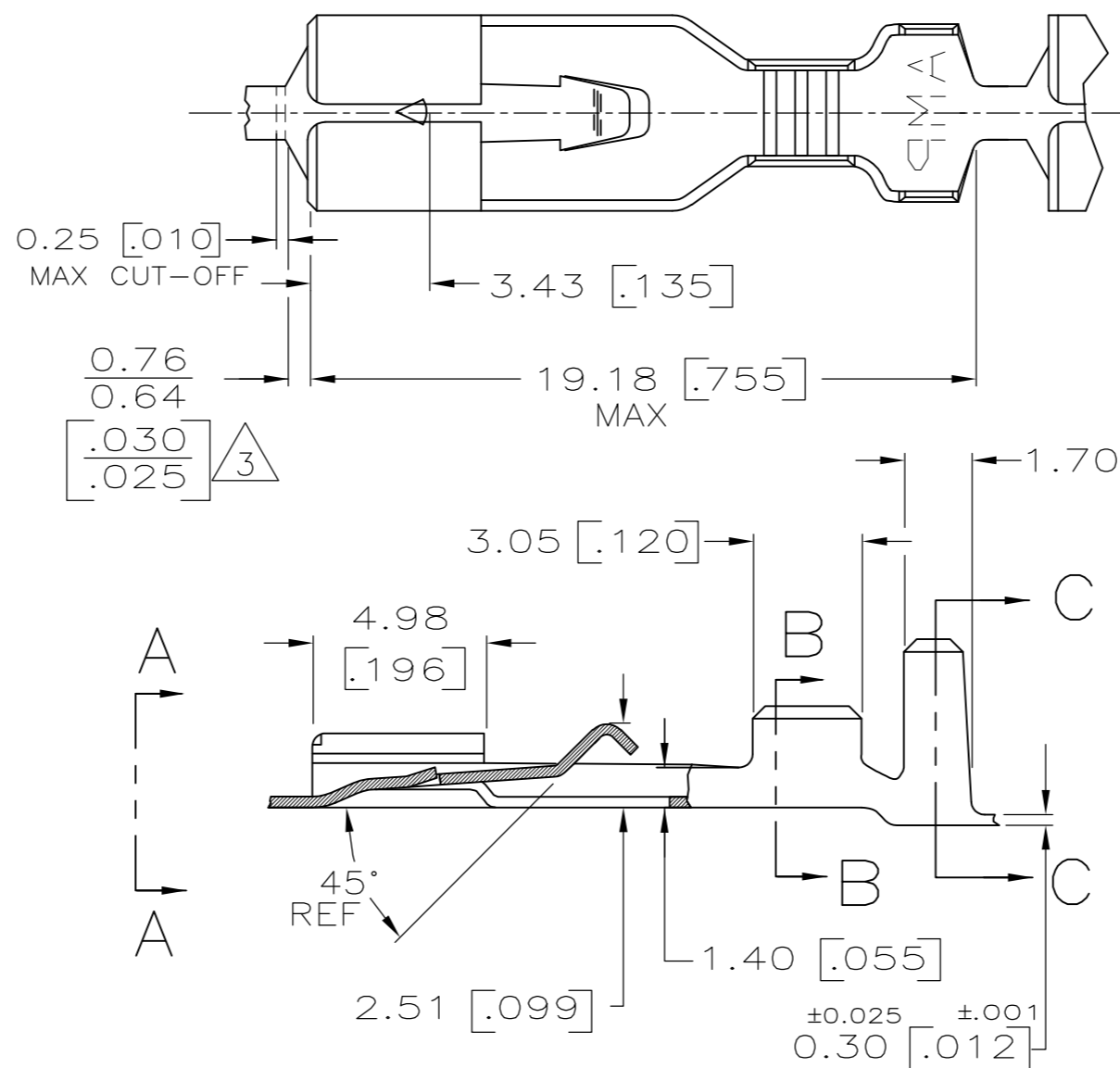

- 1 DIMENSIONS IN BRACKETS ARE IN INCHES.
- 2 CONTINUOUS STRIP ON REELS.
- 3 THIS DIMENSIONS MUST BE MAINTAINED FOR PROPER FUNCTION OF THE LATCHING MECHANISM.
- 4 WIRE SIZE IS [#20-#16] AWG.
- 5 INSULATION RANGE IS 2.29-3.30 [.090-.130] DIA.

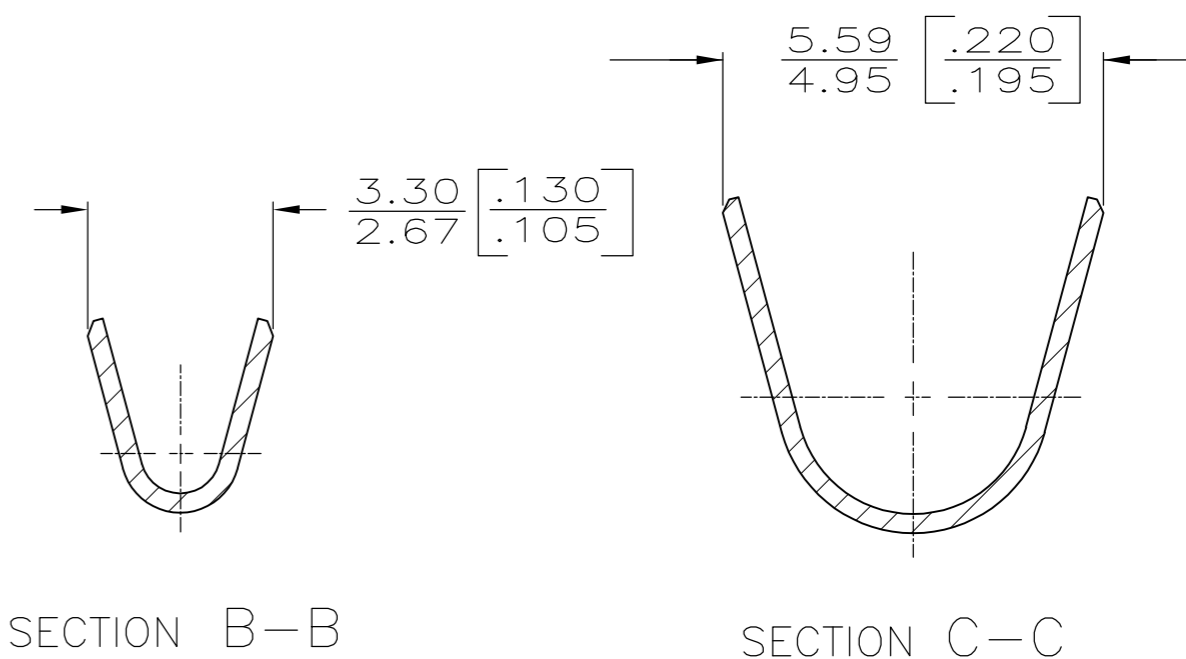
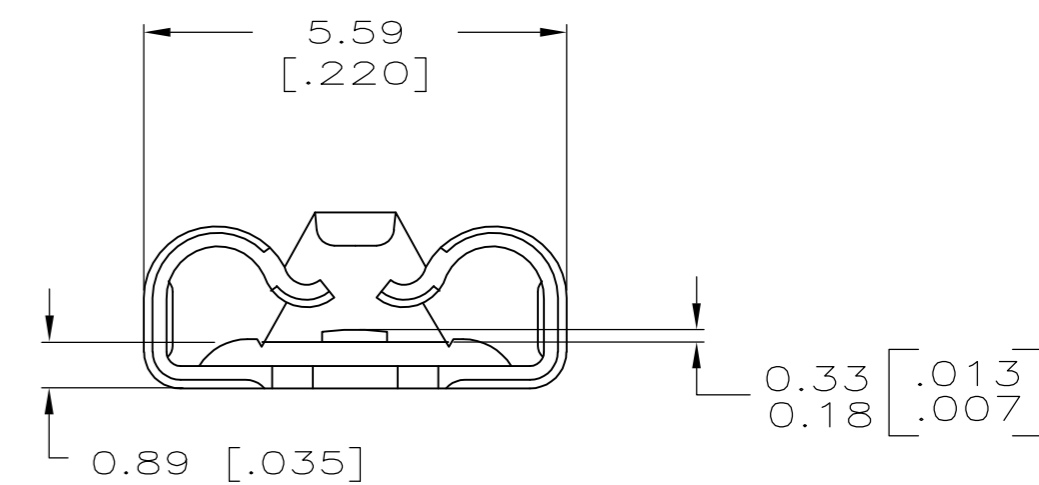

1217580-1  
PART NO.

THIS DRAWING IS A CONTROLLED DOCUMENT.		DWN	JR RUTH	30JAN01		RECEPTACLE, POSITIVE-LOCK, 4.75 [.187] SERIES		
DIMENSIONS: mm [INCHES]		CHK	MS FEHER	30JAN01		NAME	SIZE	CAGE CODE
TOLERANCES UNLESS OTHERWISE SPECIFIED:		APVD	N DEIBERT	30JAN01		PRODUCT SPEC	DRAWING NO	RESTRICTED TO
0 PLC ± -		APPLICATION SPEC				SCALE	SHEET	REV
1 PLC ± -		WEIGHT			A2	00779	C=1217580	
2 PLC ± 0.25 [.010]		CUSTOMER DRAWING			SCALE	5:1	SHEET	
3 PLC ± -							1 of 1	
4 PLC ± -							REV	
ANGLES ± -							D	
FINISH								
BRASS								
0.002032 [.000080] MIN TIN								