

REVISION HISTORY				
REV	DESCRIPTION	BY	DATE	ECN
0	FIRST ISSUE	T.N	11/02/10	8882

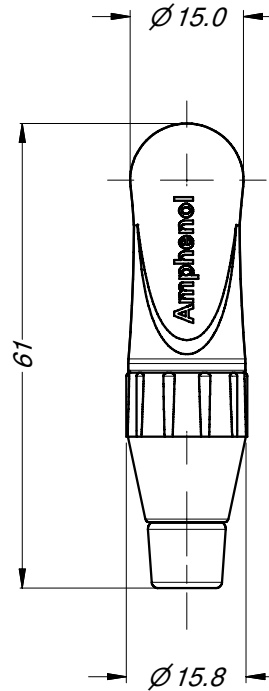
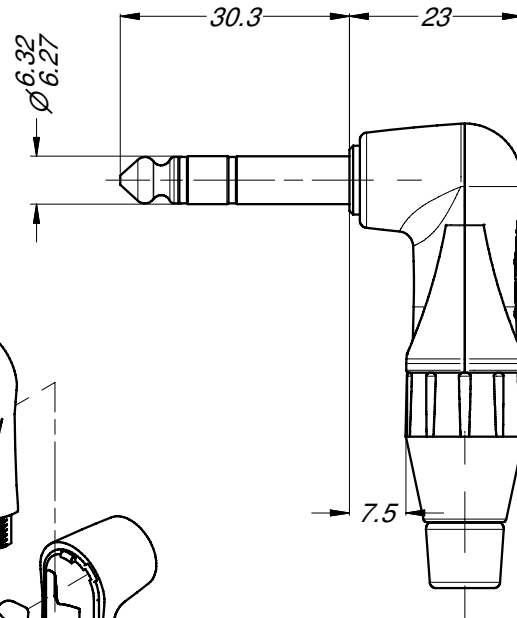
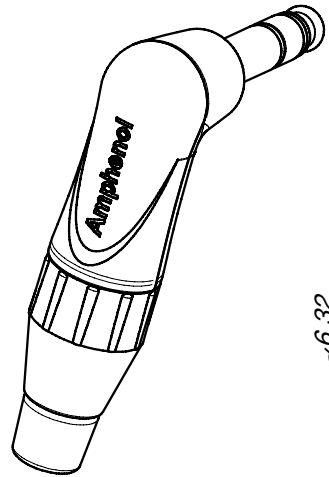

PART NUMBER BREAKDOWN

TS3R B J - AU

SERIES DESIGNATION: TS3R
 SHELL FINISH: BLANK: NICKEL, B: BLACK
 CONTACT FINISH: BLANK: NICKEL, AU: GOLD
 CABLE CLAMP SIZE: BLANK: STANDARD, J: LARGE

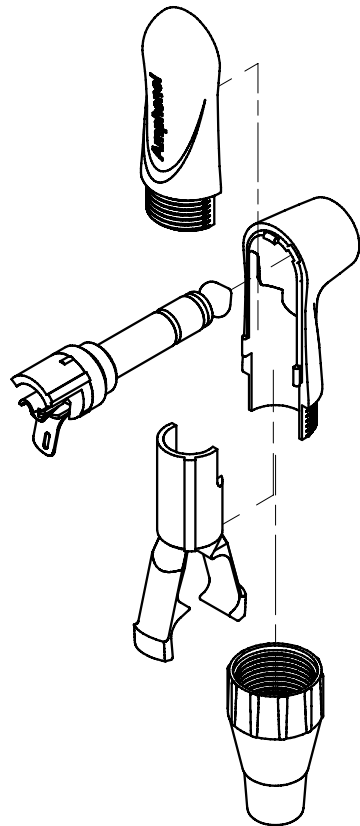

NOTES:

- STANDARD JAW CABLE CLAMP (BLACK) USED FOR CABLE OD 3.0 mm TO 5.5mm
 LARGE JAW CABLE CLAMP (PURPLE) USED FOR CABLE OD 5.5mm TO 6.5mm.

UNLESS OTHERWISE SPECIFIED TOLERANCE TO BE	
LINEAR	ANGULAR
X ±0.5	X' ±1
X.X ±0.1	X.X' ±30'
X.XX ±0.05	X.XX" ±15'

THIS DOCUMENT IS THE PROPERTY OF AMPHENOL AUSTRALIA PTY. LTD.
 NO PART THEREOF MAY BE REPRODUCED AND USED WITHOUT THE PRIOR WRITTEN CONSENT OF THE OWNER

MATERIAL: SEE COMPONENTS	DRN: A.H	DATE: 26/10/09
FINISH: SEE COMPONENTS	CKD: P.M	DATE: 27/10/09
DO NOT SCALE	APP'D: P.M	DATE: 27/10/09

Amphenol Amphenol Australia Pty.Ltd,
 2 Fiveways Blvd, Keysborough, VIC 3173

TITLE: 1/4" PHONE PLUG STEREO RIGHT ANGLE CUSTOMER DWG	PART No: SEE P/ No BREAKDOWN
CAD FILE: 550 10 6360 0 0 2 10	SHEET: 2/2

DIMENSIONS IN MILLIMETRES	THIRD ANGLE PROJECTION	SCALE: 1:1	SIZE: A4	CAD FILE: 550 10 6360 0 0 2 10	SHEET: 2/2
---------------------------	------------------------	------------	----------	--------------------------------	------------