

2-A, FAST-TRANSIENT, LOW-DROPOUT VOLTAGE REGULATOR

Check for Samples: [TPS7A7200-EP](#)

FEATURES

- Low Dropout Voltage: 180 mV at 2 A
- V_{IN} Range: 1.5 V to 6.5 V
- Configurable Fixed V_{OUT} Range: 0.9 V to 3.5 V
Adjustable V_{OUT} Range: 0.9 V to 5.0 V
- Very Good Load and Line Transient Response
- Stable with Ceramic Output Capacitor
- 1.5% Accuracy over Line, Load, and Temperature
- Programmable Soft-Start
- Power Good (PG) Output
- 5-mm × 5-mm QFN-20 Package

APPLICATIONS

- Wireless Infrastructure: SerDes, FPGA, DSP™
- RF Components: VCO, ADC, DAC, LVDS
- Set-Top Boxes: Amplifier, ADC, DAC, FPGA, DSP
- Wireless LAN, Bluetooth®
- PCs and Printers
- Audio and Visual

SUPPORTS DEFENSE, AEROSPACE, AND MEDICAL APPLICATIONS

- Controlled Baseline
- One Assembly and Test Site
- One Fabrication Site
- Available in Extended (–40°C to 125°C) Temperature Range
- Extended Product Life Cycle
- Extended Product-Change Notification
- Product Traceability

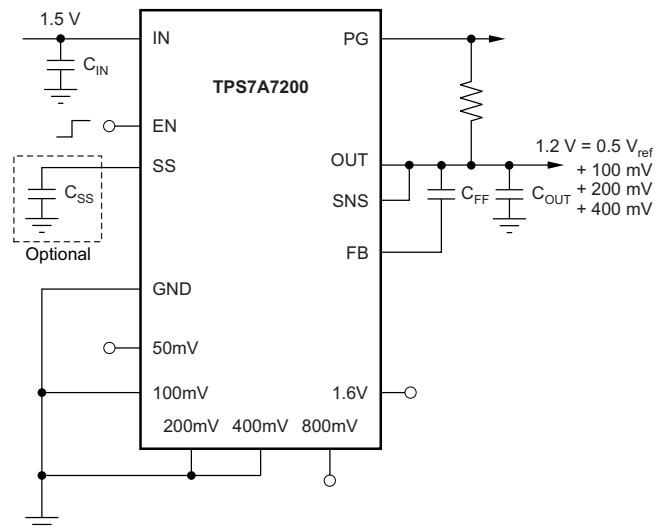

Typical Application

DESCRIPTION

The TPS7A7200 low-dropout (LDO) voltage regulator is designed for applications seeking very-low dropout capability (180 mV at 2 A) with an input voltage from 1.5 V to 6.5 V. The TPS7A7200 offers an innovative, user-configurable, output-voltage setting from 0.9 V to 3.5 V, eliminating external resistors and any associated error.

The TPS7A7200 has very fast load-transient response, is stable with ceramic output capacitors, and supports a better than 2% accuracy over line, load, and temperature. A soft-start pin allows for an application to reduce inrush into the load. Additionally, an open-drain, power-good signal allows for sequencing power rails.

The TPS7A7200 is available in a 5-mm × 5-mm, 20-pin QFN package.



Please be aware that an important notice concerning availability, standard warranty, and use in critical applications of Texas Instruments semiconductor products and disclaimers thereto appears at the end of this data sheet.

DSP is a trademark of Texas Instruments.

Bluetooth is a registered trademark of Bluetooth SIG, Inc.

All other trademarks are the property of their respective owners.

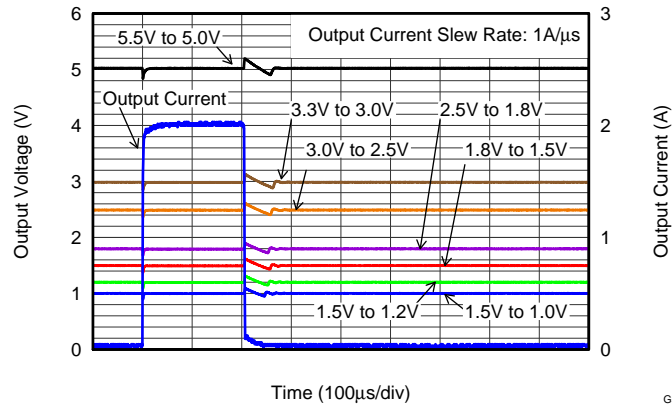

G311

**Load Transient Response with
Seven Different Results:**
1.5 V_{IN} to 1.0 V_{OUT}, 1.5 V_{IN} to 1.2 V_{OUT},
1.8 V_{IN} to 1.5 V_{OUT}, 2.5 V_{IN} to 1.8 V_{OUT},
3.0 V_{IN} to 2.5 V_{OUT}, 3.3 V_{IN} to 3.0 V_{OUT},
and 5.5 V_{IN} to 5.0 V_{OUT}



This integrated circuit can be damaged by ESD. Texas Instruments recommends that all integrated circuits be handled with appropriate precautions. Failure to observe proper handling and installation procedures can cause damage.

ESD damage can range from subtle performance degradation to complete device failure. Precision integrated circuits may be more susceptible to damage because very small parametric changes could cause the device not to meet its published specifications.

ORDERING INFORMATION⁽¹⁾

T _J	PACKAGE	ORDERABLE PART NUMBER	TOP-SIDE MARKING	VID NUMBER
–40°C to 125°C	QFN (RGW)	TPS7A7200QRGWREP	SJK	V62/13612-01XE

- (1) For the most current package and ordering information, see the Package Option Addendum at the end of this document, or see the TI website at www.ti.com.

ABSOLUTE MAXIMUM RATINGS⁽¹⁾

Over operating free-air temperature range (unless otherwise noted).

		VALUE		UNIT
		MIN	MAX	
Voltage	IN, PG, EN	–0.3	+7.0	V
	SS, FB, SNS, OUT	–0.3	V _{IN} + 0.3 ⁽²⁾	V
	50mV, 100mV, 200mV, 400mV, 800mV, 1.6V	–0.3	V _{OUT} + 0.3	V
Current	OUT	Internally limited		A
	PG (sink current into IC)	5		mA
Temperature	Junction, T _J	–40	+150	°C
	Storage, T _{stg}	–40	+150	
Electrostatic Discharge Rating ⁽³⁾	Human body model (HBM, JESD22-A114A)	2		kV
	Charged device model (CDM, JESD22-C101B.01)	500		V

- (1) Stresses beyond those listed under *Absolute Maximum Ratings* may cause permanent damage to the device. These are stress ratings only, and functional operation of the device at these or any other conditions beyond those indicated is not implied. Exposure to absolute-maximum-rated conditions for extended periods may affect device reliability.
- (2) The absolute maximum rating is V_{IN} + 0.3 V or +7.0 V, whichever is smaller.
- (3) ESD testing is performed according to the respective JESD22 JEDEC standard.

THERMAL INFORMATION

THERMAL METRIC ⁽¹⁾		TPS7A7200-EP	UNITS
		RGW	
		20 PINS	
θ _{JA}	Junction-to-ambient thermal resistance ⁽²⁾	35.7	°C/W
θ _{JCtop}	Junction-to-case (top) thermal resistance ⁽³⁾	33.6	
θ _{JB}	Junction-to-board thermal resistance ⁽⁴⁾	15.2	
ψ _{JT}	Junction-to-top characterization parameter ⁽⁵⁾	0.4	
ψ _{JB}	Junction-to-board characterization parameter ⁽⁶⁾	15.4	
θ _{JCbot}	Junction-to-case (bottom) thermal resistance ⁽⁷⁾	3.8	

- (1) For more information about traditional and new thermal metrics, see the *IC Package Thermal Metrics* application report, [SPRA953](http://www.ti.com/lit/zip/Spra953).
- (2) The junction-to-ambient thermal resistance under natural convection is obtained in a simulation on a JEDEC-standard, high-K board, as specified in JESD51-7, in an environment described in JESD51-2a.
- (3) The junction-to-case (top) thermal resistance is obtained by simulating a cold plate test on the package top. No specific JEDEC-standard test exists, but a close description can be found in the ANSI SEMI standard G30-88.
- (4) The junction-to-board thermal resistance is obtained by simulating in an environment with a ring cold plate fixture to control the PCB temperature, as described in JESD51-8.
- (5) The junction-to-top characterization parameter, ψ_{JT}, estimates the junction temperature of a device in a real system and is extracted from the simulation data for obtaining θ_{JA}, using a procedure described in JESD51-2a (sections 6 and 7).
- (6) The junction-to-board characterization parameter, ψ_{JB}, estimates the junction temperature of a device in a real system and is extracted from the simulation data for obtaining θ_{JA}, using a procedure described in JESD51-2a (sections 6 and 7).
- (7) The junction-to-case (bottom) thermal resistance is obtained by simulating a cold plate test on the exposed (power) pad. No specific JEDEC standard test exists, but a close description can be found in the ANSI SEMI standard G30-88.

ELECTRICAL CHARACTERISTICS

Over operating temperature range ($T_J = -40^\circ\text{C}$ to $+125^\circ\text{C}$), $1.425\text{ V} \leq V_{IN} \leq 6.5\text{ V}$, $V_{IN} \geq V_{OUT(\text{TARGET})} + 0.3\text{ V}$ or $V_{IN} \geq V_{OUT(\text{TARGET})} + 0.5\text{ V}^{(1)(2)}$, OUT connected to $50\ \Omega$ to GND⁽³⁾, $V_{EN} = 1.1\text{ V}$, $C_{OUT} = 10\ \mu\text{F}$, $C_{SS} = 10\ \text{nF}$, $C_{FF} = 0\ \text{pF}^{(4)}$, and PG pin pulled up to V_{IN} with $100\ \text{k}\Omega$, $27\ \text{k}\Omega \leq R_2 \leq 33\ \text{k}\Omega$ for adjustable configuration⁽⁵⁾, unless otherwise noted.

Typical values are at $T_J = +25^\circ\text{C}$.

PARAMETER		TEST CONDITIONS	MIN	TYP	MAX	UNIT
V_{IN}	Input voltage range		1.425		6.5	V
$V_{(SS)}$	SS pin voltage			0.5		V
V_{OUT}	Output voltage range	Adjustable with external feedback resistors	0.9		5.0	V
		Fixed with voltage setting pins	0.9		3.5	
	Output voltage accuracy ⁽⁶⁾⁽⁷⁾	Adjustable, $25\ \text{mA} \leq I_{OUT} \leq 2\ \text{A}$	-2.0		+2.0	%
		Fixed, $25\ \text{mA} \leq I_{OUT} \leq 2\ \text{A}$	-3.0		+3.0	
$\Delta V_{O(\Delta VI)}$	Line regulation	$I_{OUT} = 25\ \text{mA}$		0.01		%/V
$\Delta V_{O(\Delta IO)}$	Load regulation	$25\ \text{mA} \leq I_{OUT} \leq 2\ \text{A}$		0.1		%/A
$V_{(DO)}$	Dropout voltage ⁽⁸⁾	$V_{OUT} \leq 3.3\ \text{V}$, $I_{OUT} = 2\ \text{A}$, $V_{(FB)} = \text{GND}$			180	mV
		$3.3\ \text{V} < V_{OUT}$, $I_{OUT} = 2\ \text{A}$, $V_{(FB)} = \text{GND}$			470	mV
$I_{(LIM)}$	Output current limit	V_{OUT} forced at $0.9 \times V_{OUT(\text{TARGET})}$, $V_{IN} = 3.3\ \text{V}$, $V_{OUT(\text{TARGET})} = 0.9\ \text{V}$	2.4	3.1		A
$I_{(GND)}$	GND pin current	Full load, $I_{OUT} = 2\ \text{A}$		2.6		mA
		Minimum load, $V_{IN} = 6.5\ \text{V}$, $V_{OUT(\text{TARGET})} = 0.9\ \text{V}$, $I_{OUT} = 25\ \text{mA}$			4	mA
		Shutdown, PG = (open), $V_{IN} = 6.5\ \text{V}$, $V_{OUT(\text{TARGET})} = 0.9\ \text{V}$, $V_{(EN)} < 0.5\ \text{V}$		0.1	5	μA
$I_{(EN)}$	EN pin current	$V_{IN} = 6.5\ \text{V}$, $V_{(EN)} = 0\ \text{V}$ and $6.5\ \text{V}$			± 0.1	μA
$V_{IL(\text{EN})}$	EN pin low-level input voltage (disable device)		0		0.5	V
$V_{IH(\text{EN})}$	EN pin high-level input voltage (enable device)		1.1		6.5	V
$V_{IT(\text{PG})}$	PG pin threshold	For the direction PG \downarrow with decreasing V_{OUT}	$0.85V_{OUT}$	$0.9V_{OUT}$	$0.96V_{OUT}$	V
$V_{hys(\text{PG})}$	PG pin hysteresis	For PG \uparrow		$0.02V_{OUT}$		V
$V_{OL(\text{PG})}$	PG pin low-level output voltage	$V_{OUT} < V_{IT(\text{PG})}$, $I_{PG} = -1\ \text{mA}$ (current into device)			0.4	V
$I_{lk(\text{PG})}$	PG pin leakage current	$V_{OUT} > V_{IT(\text{PG})}$, $V_{(PG)} = 6.5\ \text{V}$			1	μA
$I_{(SS)}$	SS pin charging current	$V_{(SS)} = \text{GND}$, $V_{IN} = 3.3\ \text{V}$	3.5	5.1	7.2	μA
V_n	Output noise voltage	BW = 100 Hz to 100 kHz, $V_{IN} = 1.5\ \text{V}$, $V_{OUT} = 1.2\ \text{V}$, $I_{OUT} = 2\ \text{A}$		40.65		μV_{RMS}
T_{sd}	Thermal shutdown temperature	Shutdown, temperature increasing		+160		$^\circ\text{C}$
		Reset, temperature decreasing		+140		$^\circ\text{C}$
T_J	Operating junction temperature		-40		+125	$^\circ\text{C}$

- (1) When $V_{OUT} \leq 3.5\ \text{V}$, $V_{IN} \geq (V_{OUT} + 0.3\ \text{V})$ or $1.425\ \text{V}$, whichever is greater; when $V_{OUT} > 3.5\ \text{V}$, $V_{IN} \geq (V_{OUT} + 0.5\ \text{V})$.
- (2) $V_{OUT(\text{TARGET})}$ is the calculated target V_{OUT} value from the output voltage setting pins: 50mV, 100mV, 200mV, 400mV, 800mV, and 1.6V in fixed configuration, or the expected V_{OUT} value set by external feedback resistors in adjustable configuration.
- (3) This 50- Ω load is disconnected when the test conditions specify an I_{OUT} value.
- (4) C_{FF} is the capacitor between FB pin and OUT
- (5) R_2 is the bottom-side of the feedback resistor between the FB pin and OUT. See [Figure 40](#) for details.
- (6) When the TPS7A7200 is connected to external feedback resistors at the FB pin, external resistor tolerances are not included.
- (7) The TPS7A7200 is not tested at $V_{OUT} = 0.9\ \text{V}$, $2.7\ \text{V} \leq V_{IN} \leq 6.5\ \text{V}$, and $500\ \text{mA} \leq I_{OUT} \leq 2\ \text{A}$ because the power dissipation is higher than the maximum rating of the package. Also, this accuracy specification does not apply on any application condition that exceeds the power dissipation limit of the package.
- (8) $V_{(DO)}$ is not defined for output voltage settings below 1.2 V.

FUNCTIONAL BLOCK DIAGRAM

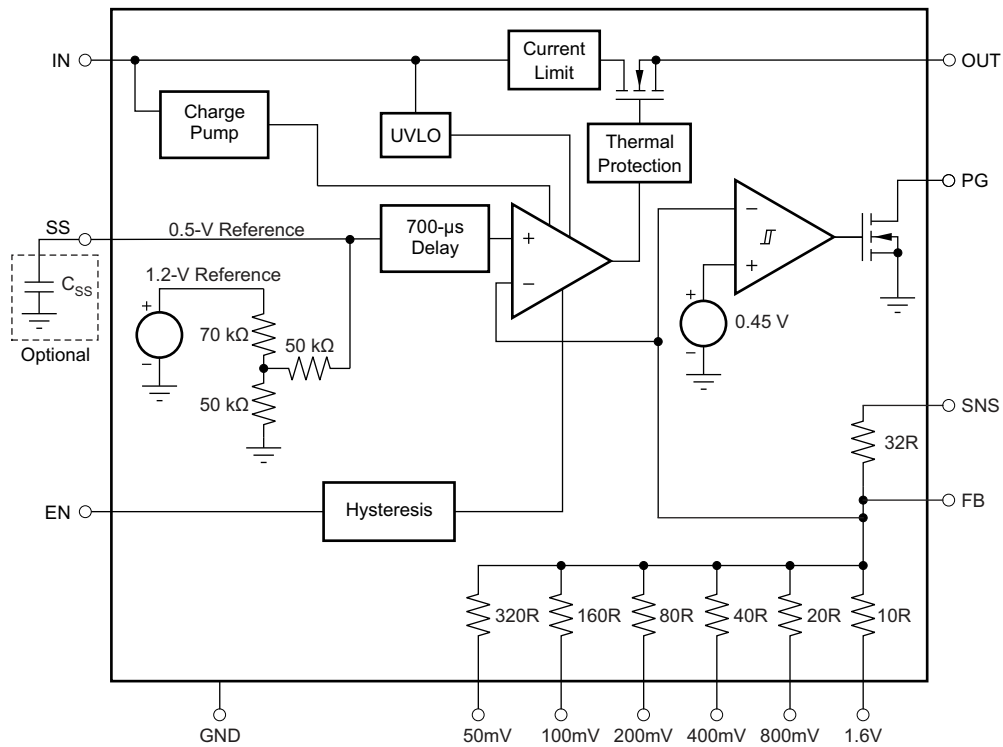

NOTE: 320R = 1.024 MΩ (that is, 1R = 3.2 kΩ).

Figure 1. Functional Block Diagram

PIN CONFIGURATIONS

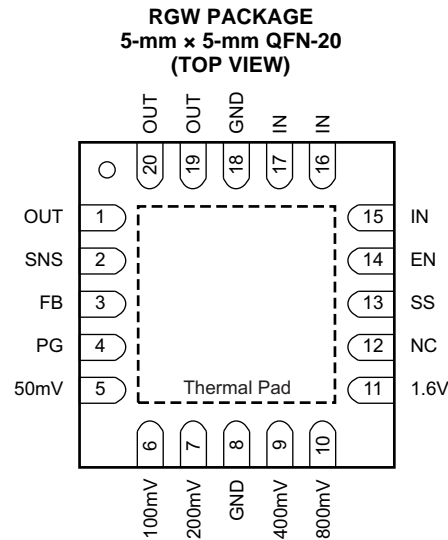

PIN DESCRIPTIONS

NAME	PIN	DESCRIPTION
50mV, 100mV, 200mV, 400mV, 800mV, 1.6V	5, 6, 7, 9, 10, 11	Output voltage setting pins. These pins should be connected to ground or left floating. Connecting these pins to ground increases the output voltage by the value of the pin name; multiple pins can be simultaneously connected to GND to select the desired output voltage. Leave these pins floating (open) when not in use. See the USER-CONFIGURABLE OUTPUT VOLTAGE section for more details.
EN	14	Enable pin. Driving this pin to logic high enables the device; driving the pin to logic low disables the device. See the ENABLE AND SHUTDOWN THE DEVICE section for more details.
FB	3	Output voltage feedback pin. Connected to the error amplifier. See the USER-CONFIGURABLE OUTPUT VOLTAGE and TRADITIONAL ADJUSTABLE CONFIGURATION sections for more details. A 220-pF ceramic capacitor from FB pin to OUT is highly recommended.
GND	8, 18	Ground pin.
IN	15, 16, 17	Unregulated supply voltage pin. It is recommended to connect an input capacitor to this pin. See INPUT CAPACITOR REQUIREMENTS for more details.
NC	12	Not internally connected. The NC pin is not connected to any electrical node. It is strongly recommended to connect this pin and the thermal pad to a large-area ground plane. See the Power Dissipation section for more details.
OUT	1, 19, 20	Regulated output pin. A 4.7- μ F or larger capacitance is required for stability. See OUTPUT CAPACITOR REQUIREMENTS for more details.
PG	4	Active-high power good pin. An open-drain output that indicates when the output voltage reaches 90% of the target. See POWER GOOD for more details.
SNS	2	Output voltage sense input pin. See the USER-CONFIGURABLE OUTPUT VOLTAGE and TRADITIONAL ADJUSTABLE CONFIGURATION sections for more details.
SS	13	Soft-start pin. Leaving this pin open provides soft-start of the default setting. Connecting an external capacitor between this pin and the ground enables the soft-start function by forming an RC-delay circuit in combination with the integrated resistance on the silicon. See the SOFT-START section for more details.
Thermal Pad		It is strongly recommended to connect the thermal pad to a large-area ground plane. If available, connect an electrically-floating, dedicated thermal plane to the thermal pad as well.

TYPICAL CHARACTERISTICS

At $T_J = +25^\circ\text{C}$, $V_{IN} = V_{OUT(TARGET)} + 0.3\text{ V}$, $I_{OUT} = 25\text{ mA}$, $V_{(EN)} = V_{IN}$, $C_{IN} = 10\text{ }\mu\text{F}$, $C_{OUT} = 10\text{ }\mu\text{F}$, $C_{(SS)} = 10\text{ nF}$, and the PG pin pulled up to V_{IN} with 100-k Ω pull-up resistor, unless otherwise noted.

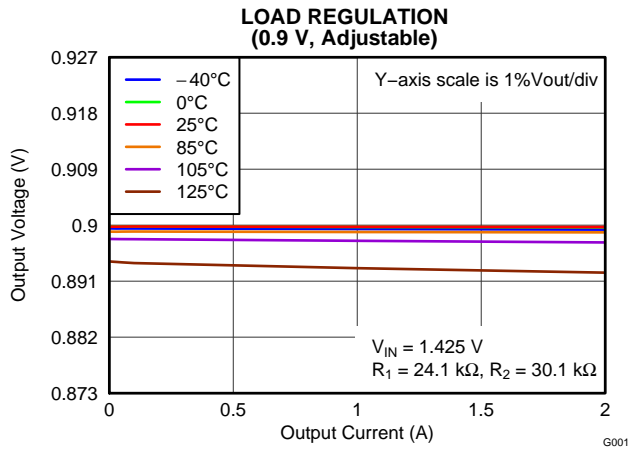

Figure 2.

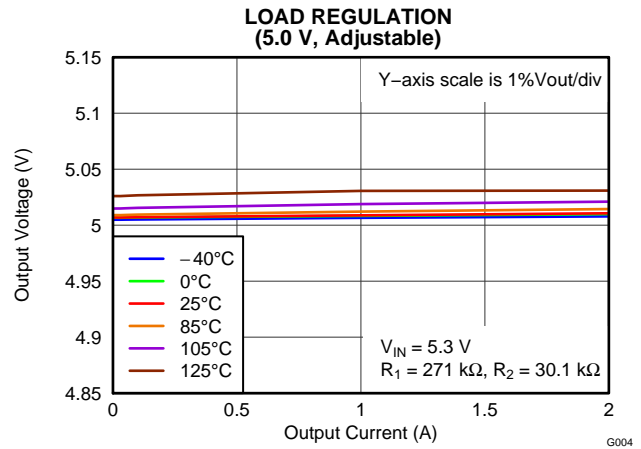

Figure 3.

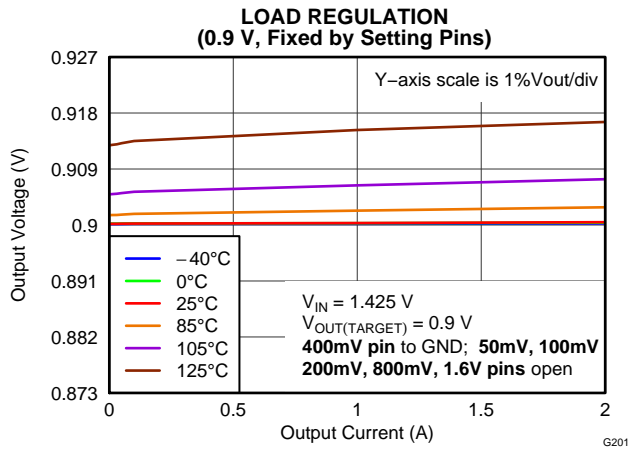

Figure 4.

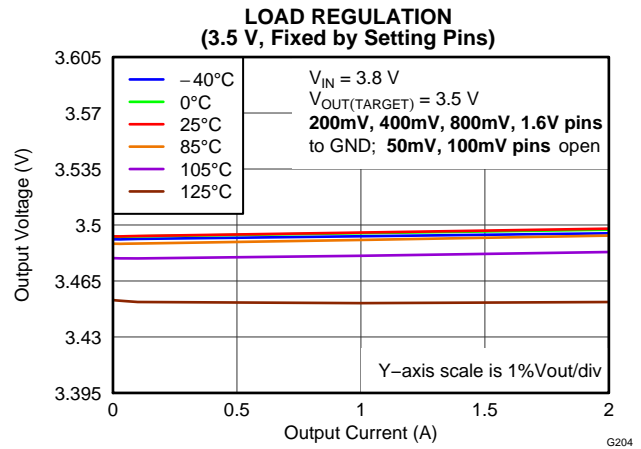

Figure 5.

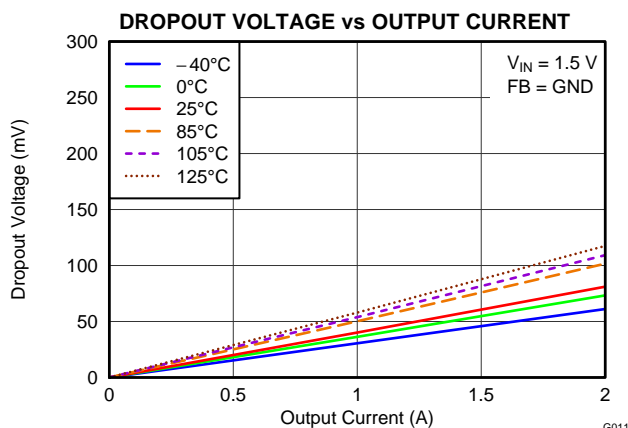

Figure 6.

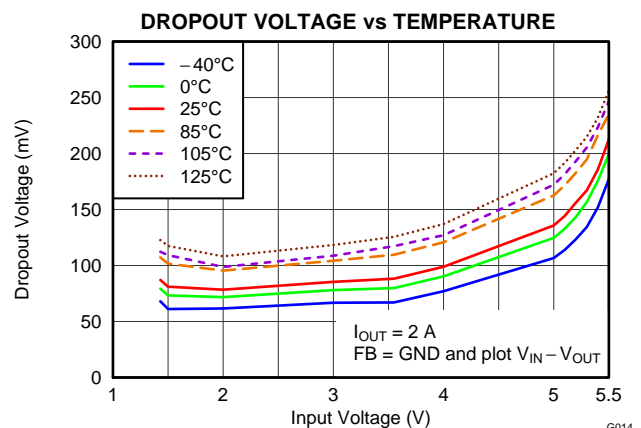

Figure 7.

TYPICAL CHARACTERISTICS (continued)

At $T_J = +25^\circ\text{C}$, $V_{IN} = V_{OUT(TARGET)} + 0.3\text{ V}$, $I_{OUT} = 25\text{ mA}$, $V_{(EN)} = V_{IN}$, $C_{IN} = 10\text{ }\mu\text{F}$, $C_{OUT} = 10\text{ }\mu\text{F}$, $C_{(SS)} = 10\text{ nF}$, and the PG pin pulled up to V_{IN} with 100-k Ω pull-up resistor, unless otherwise noted.

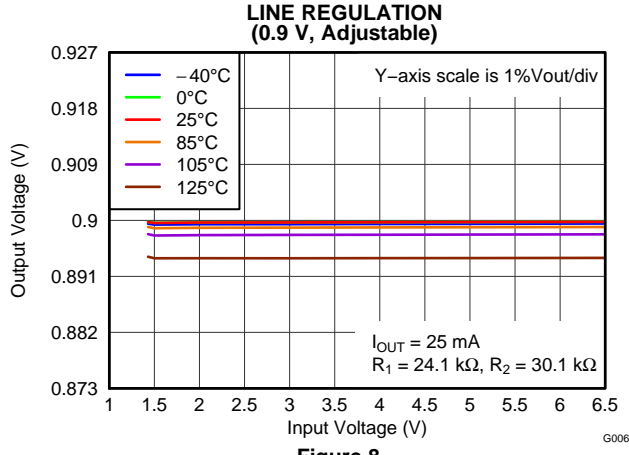

Figure 8.

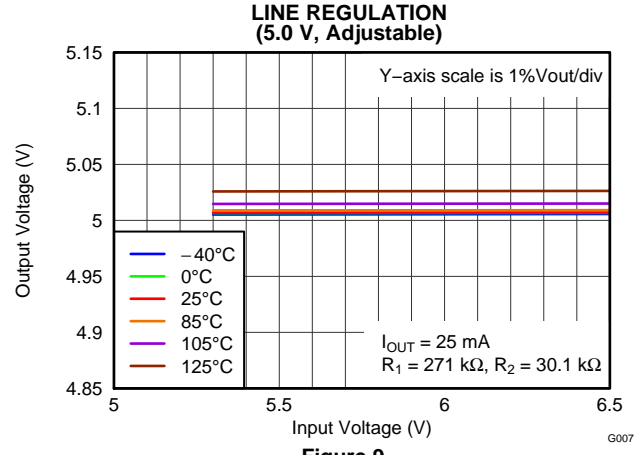

Figure 9.

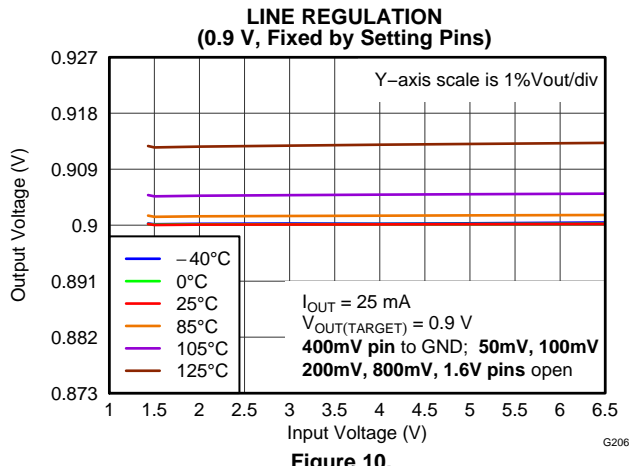

Figure 10.

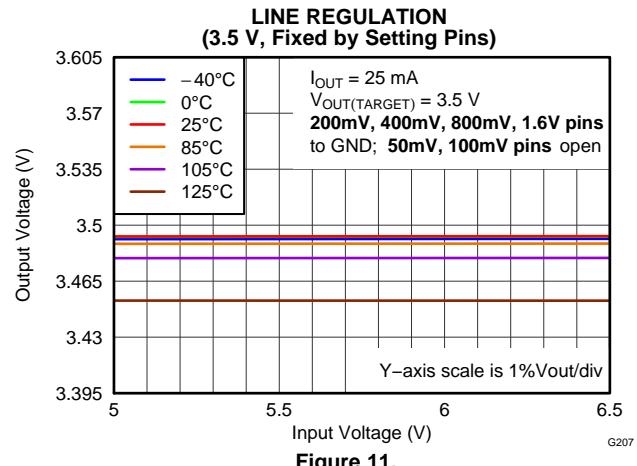

Figure 11.

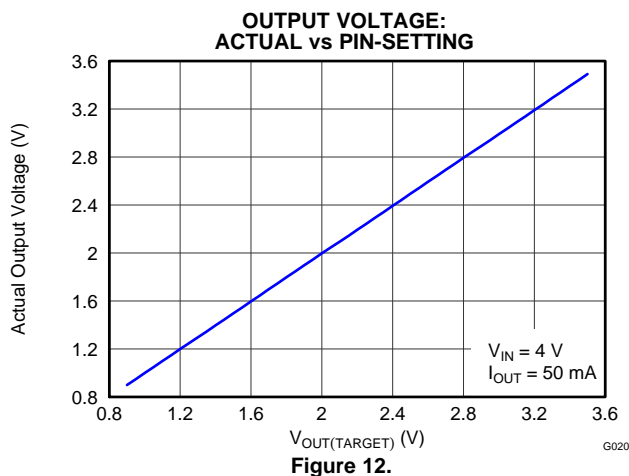

Figure 12.

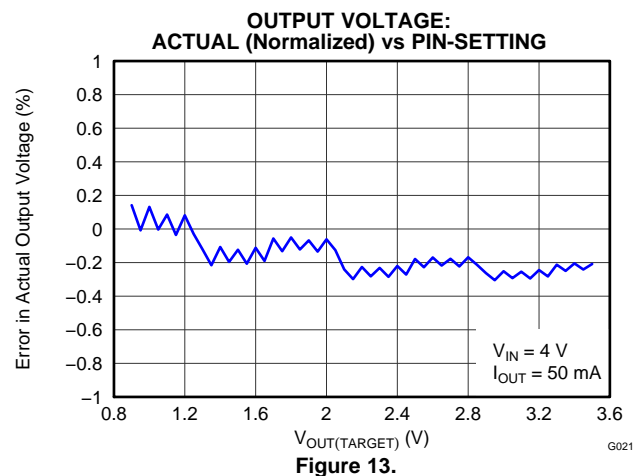

Figure 13.

TYPICAL CHARACTERISTICS (continued)

At $T_J = +25^\circ\text{C}$, $V_{IN} = V_{OUT(TARGET)} + 0.3\text{ V}$, $I_{OUT} = 25\text{ mA}$, $V_{(EN)} = V_{IN}$, $C_{IN} = 10\text{ }\mu\text{F}$, $C_{OUT} = 10\text{ }\mu\text{F}$, $C_{(SS)} = 10\text{ nF}$, and the PG pin pulled up to V_{IN} with 100-k Ω pull-up resistor, unless otherwise noted.

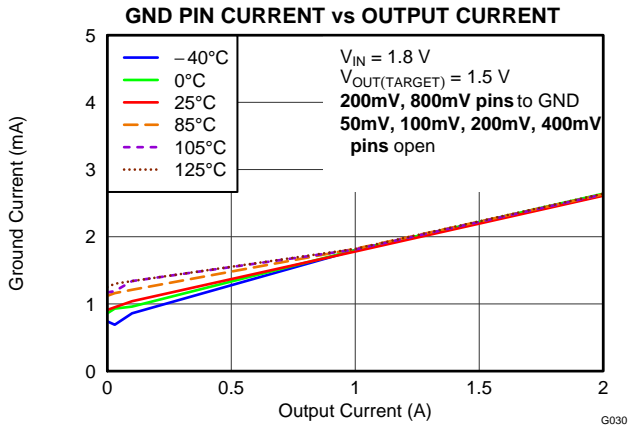

Figure 14.

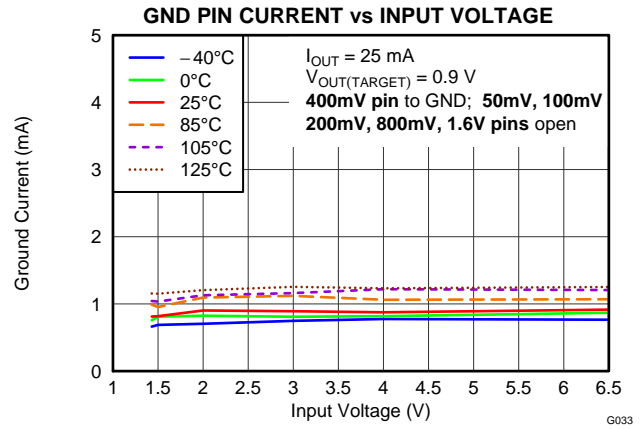

Figure 15.

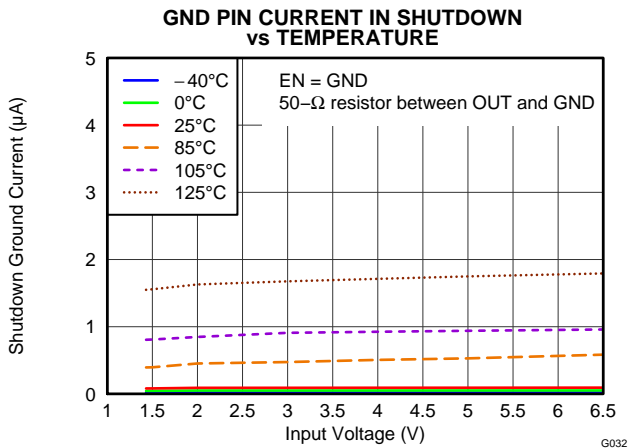

Figure 16.

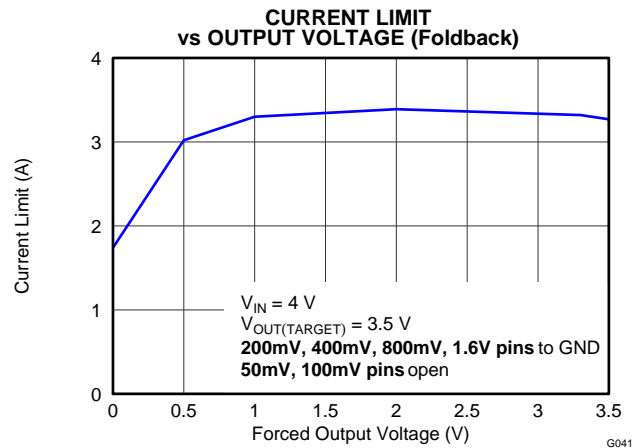

Figure 17.

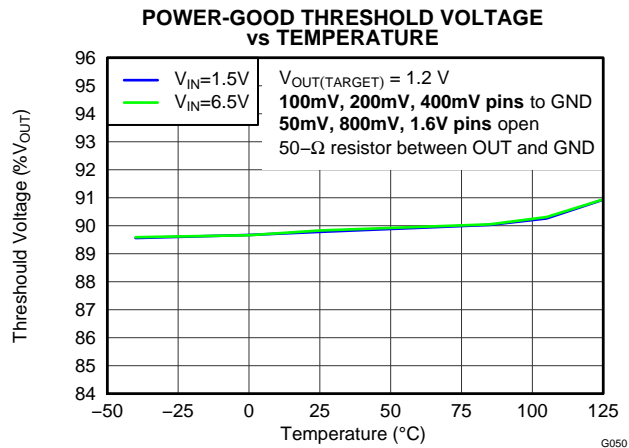

Figure 18.

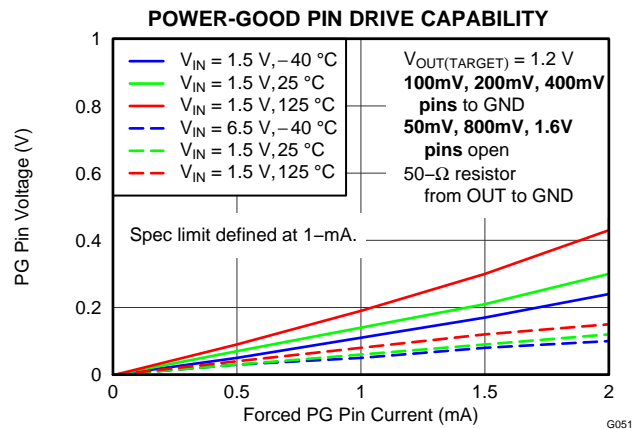
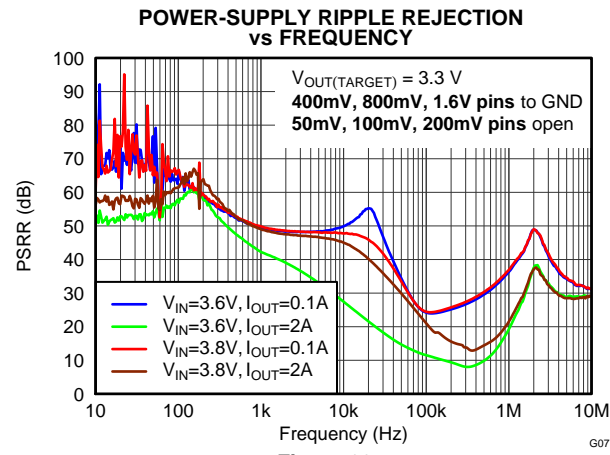
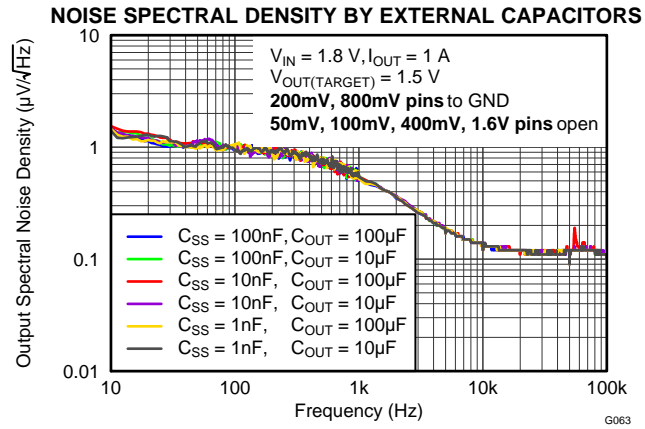
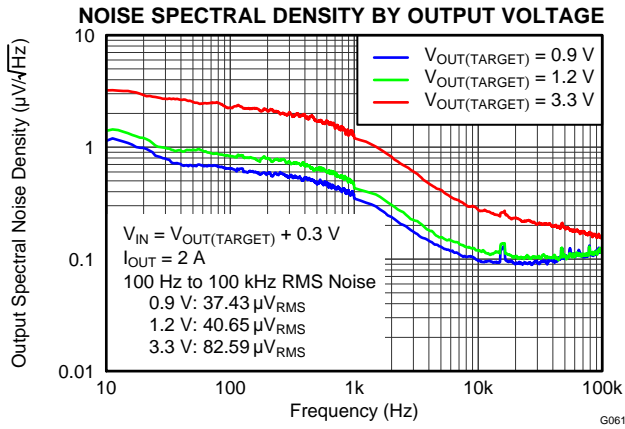

Figure 19.

TYPICAL CHARACTERISTICS (continued)

At $T_J = +25^\circ\text{C}$, $V_{IN} = V_{OUT(TARGET)} + 0.3\text{ V}$, $I_{OUT} = 25\text{ mA}$, $V_{(EN)} = V_{IN}$, $C_{IN} = 10\text{ }\mu\text{F}$, $C_{OUT} = 10\text{ }\mu\text{F}$, $C_{(SS)} = 10\text{ nF}$, and the PG pin pulled up to V_{IN} with 100-k Ω pull-up resistor, unless otherwise noted.



TYPICAL CHARACTERISTICS (continued)

At $T_J = +25^\circ\text{C}$, $V_{IN} = V_{OUT(TARGET)} + 0.3\text{ V}$, $I_{OUT} = 25\text{ mA}$, $V_{(EN)} = V_{IN}$, $C_{IN} = 10\text{ }\mu\text{F}$, $C_{OUT} = 10\text{ }\mu\text{F}$, $C_{(SS)} = 10\text{ nF}$, and the PG pin pulled up to V_{IN} with 100-k Ω pull-up resistor, unless otherwise noted.

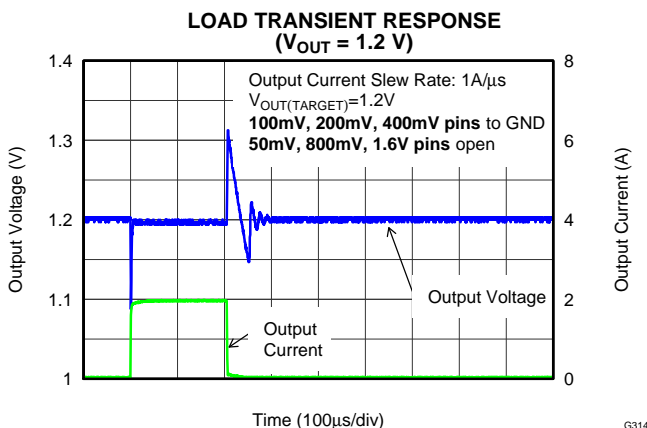

Figure 23.

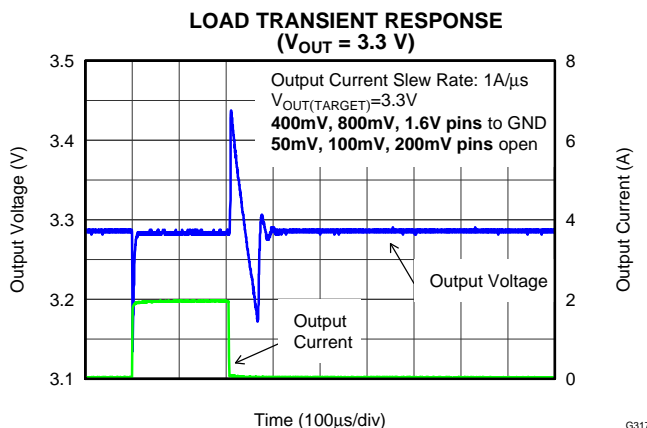

Figure 24.

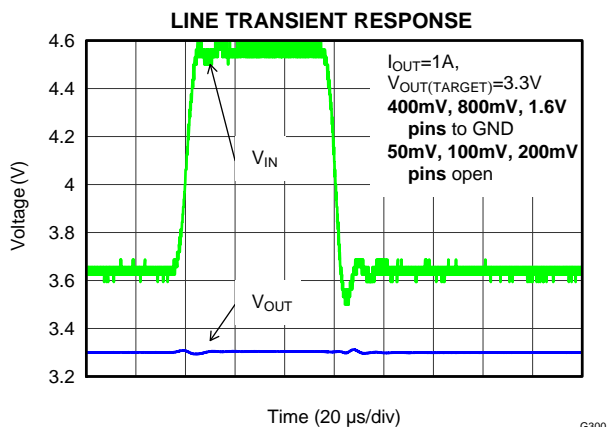

Figure 25.

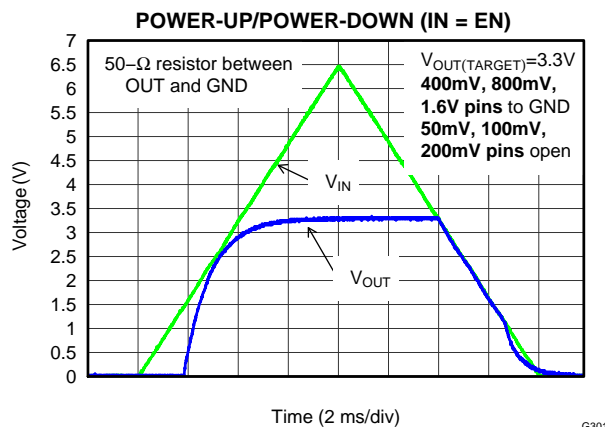

Figure 26.

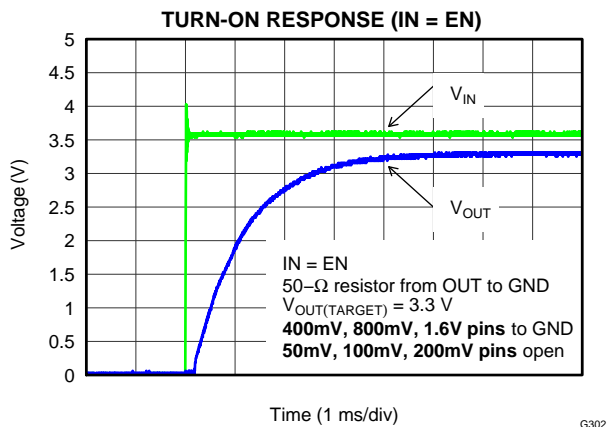

Figure 27.

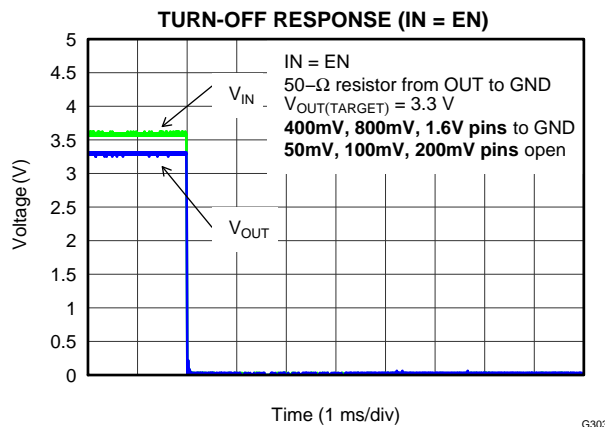
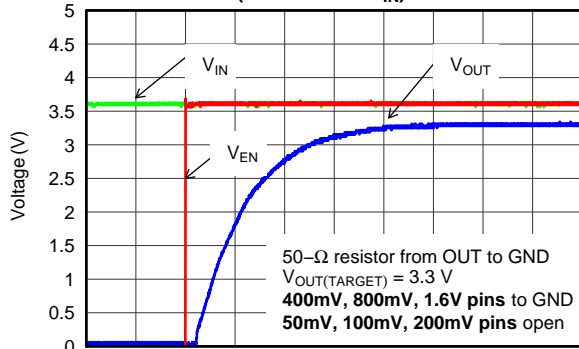

Figure 28.

TYPICAL CHARACTERISTICS (continued)

At $T_J = +25^\circ\text{C}$, $V_{IN} = V_{OUT(TARGET)} + 0.3\text{ V}$, $I_{OUT} = 25\text{ mA}$, $V_{(EN)} = V_{IN}$, $C_{IN} = 10\text{ }\mu\text{F}$, $C_{OUT} = 10\text{ }\mu\text{F}$, $C_{SS} = 10\text{ nF}$, and the PG pin pulled up to V_{IN} with 100-k Ω pull-up resistor, unless otherwise noted.

**EN PULSE ON RESPONSE
(Over Stable V_{IN})**



Time (1 ms/div)
Figure 29.

G304

**EN PULSE OFF RESPONSE
(Over Stable V_{IN})**

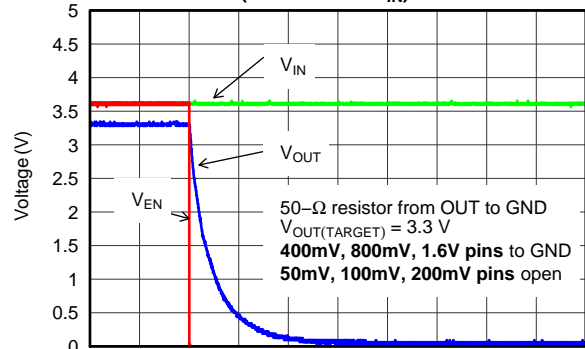

Time (1 ms/div)
Figure 30.

G305

SOFT-START DELAY vs C_{SS} (Enlarged View)

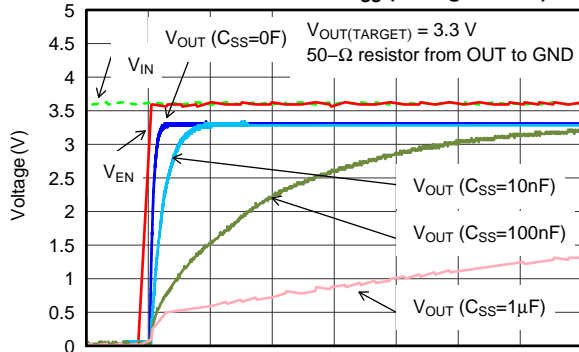

Time (5 ms/div)
Figure 31.

G306

SOFT-START DELAY vs C_{SS} (Reduced View)

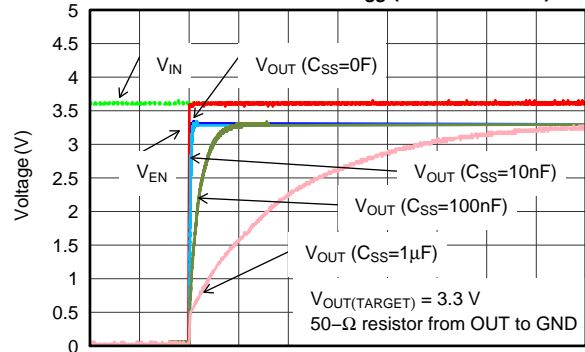

Time (50 ms/div)
Figure 32.

G307

SOFT-START DELAY vs C_{SS}

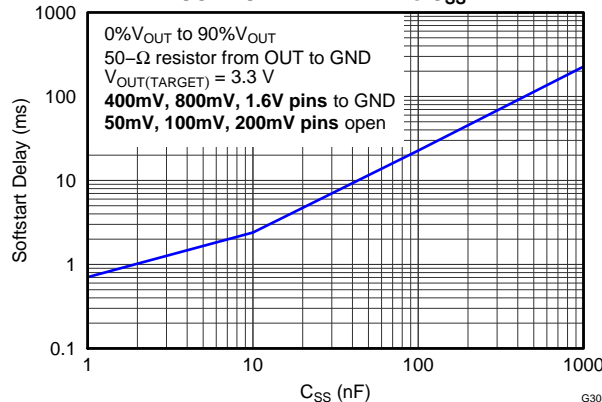

Figure 33.

G308

APPLICATION INFORMATION

OVERVIEW

The TPS7A7200 belongs to a family of new-generation LDO regulators that uses innovative circuitry to offer very-low dropout voltage along with the flexibility of a programmable output voltage.

The dropout voltage for this LDO regulator family is 0.18 V at 2 A. This voltage is ideal for making the TPS7A7200 into a point-of-load (POL) regulator because 0.18 V at 2 A is lower than any voltage gap among the most common voltage rails: 1.2 V, 1.5 V, 1.8 V, 2.5 V, 3.0 V, and 3.3 V. This device offers a fully user-configurable output voltage setting method. The TPS7A7200 output voltage can be programmed to any target value from 0.9 V to 3.5 V in 50-mV steps.

Another big advantage of using the TPS7A7200 is the wide range of available operating input voltages: from 1.5 V to 6.5 V. The TPS7A7200 also has very good line and load transient response. All these features allow the TPS7A7200 to meet most voltage-regulator needs for under-6-V applications, using only one device so that less time is spent on inventory control.

Texas Instruments also offers different output current ratings with other family devices: the [TPS7A7100](#) (1 A) and [TPS7A7300](#) (3 A).

USER-CONFIGURABLE OUTPUT VOLTAGE

Unlike traditional LDO devices, the TPS7A7200 comes with only one orderable part number; there is no adjustable or fixed output voltage option. The output voltage of the TPS7A7200 is selectable in accordance with the names given to the output voltage setting pins: 50mV, 100mV, 200mV, 400mV, 800mV, and 1.6V. For each pin connected to the ground, the output voltage setting increases by the value associated with that pin name, starting from the value of the reference voltage of 0.5 V; floating the pin(s) has no effect on the output voltage. [Figure 34](#) through [Figure 39](#) show examples of how to program the output voltages.

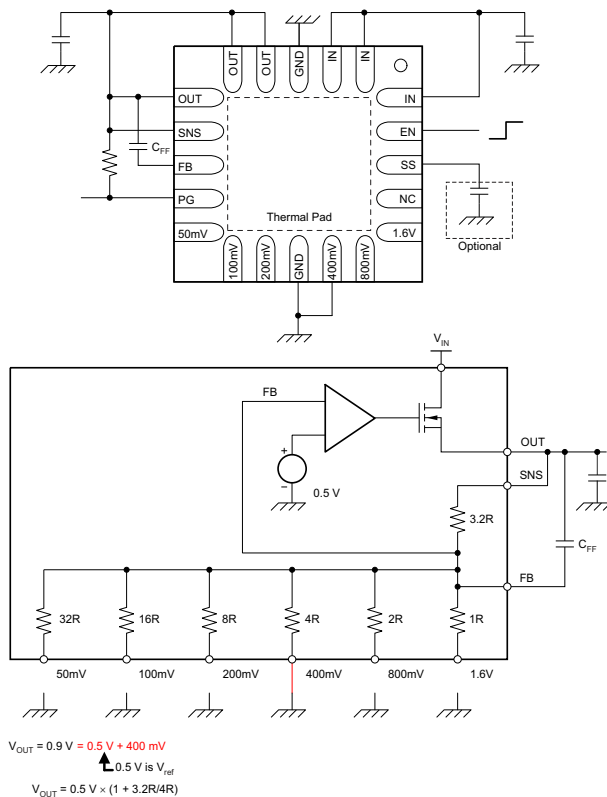

Figure 34. 0.9-V Configuration

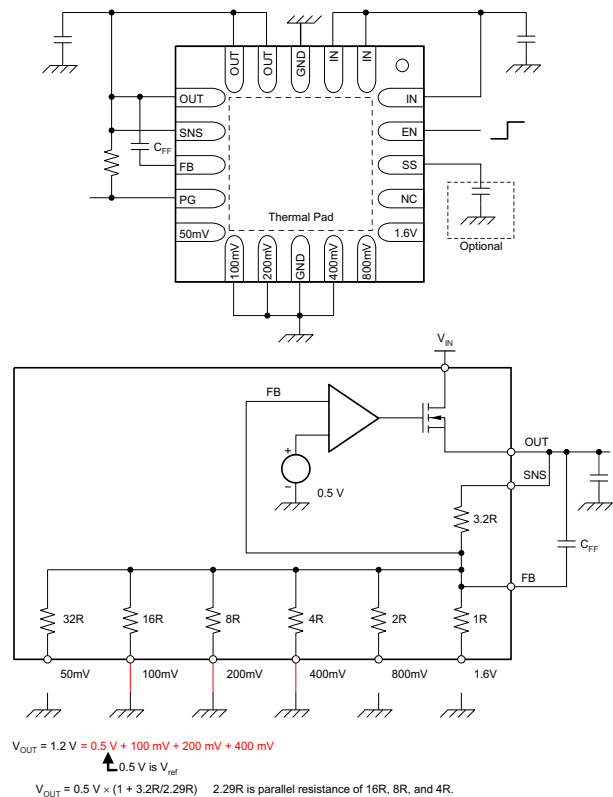

Figure 35. 1.2-V Configuration

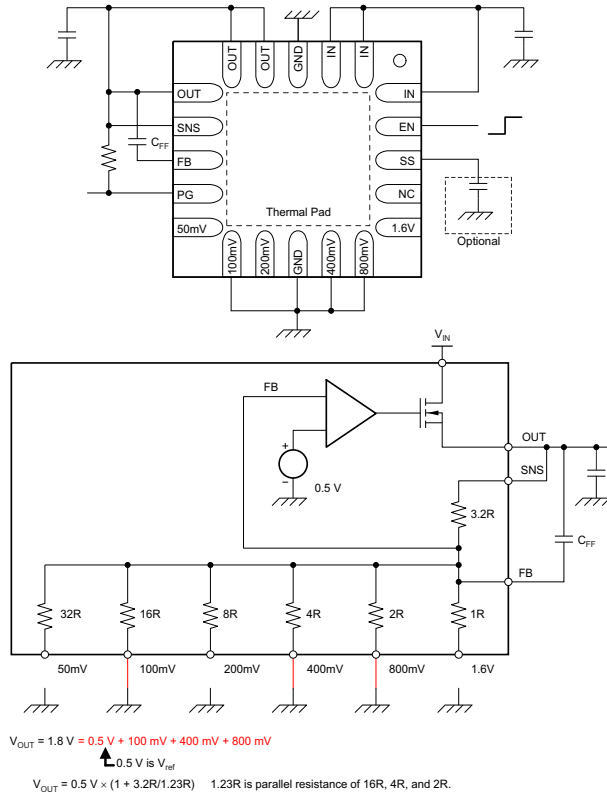

Figure 36. 1.8-V Configuration

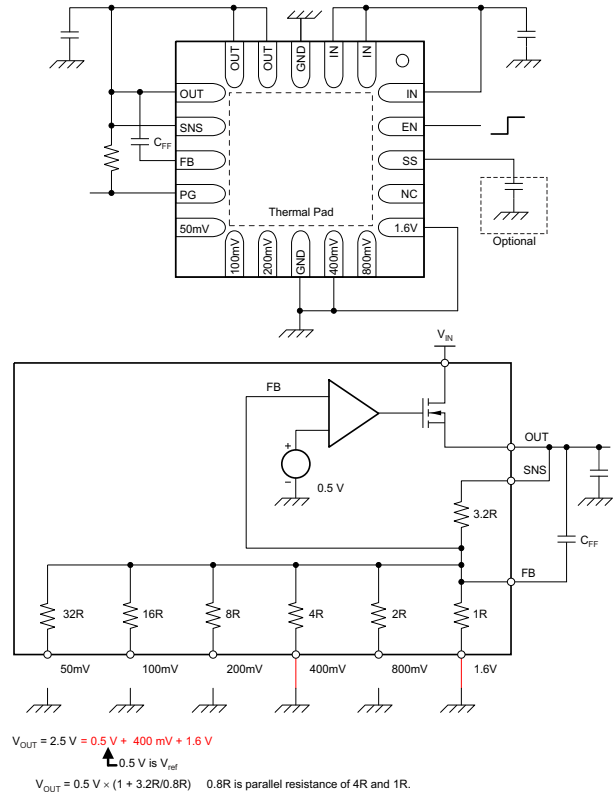

Figure 37. 2.5-V Configuration

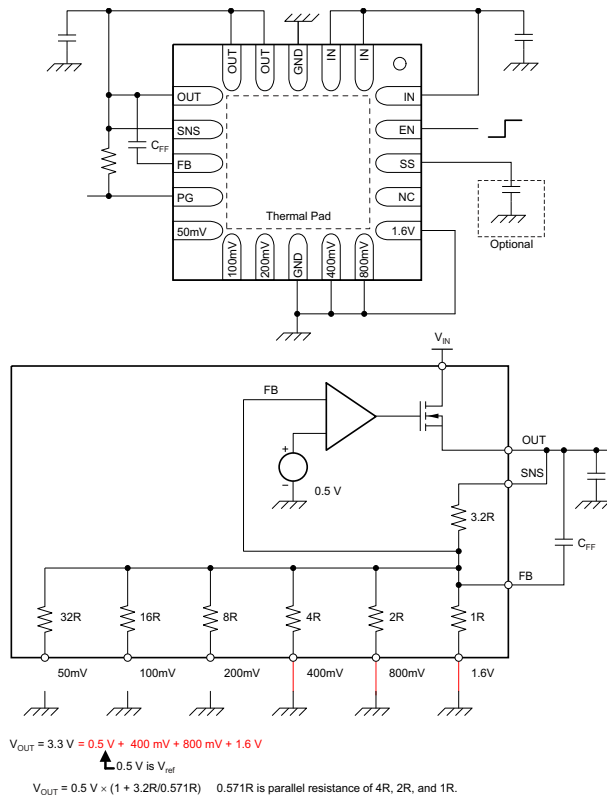

Figure 38. 3.3-V Configuration

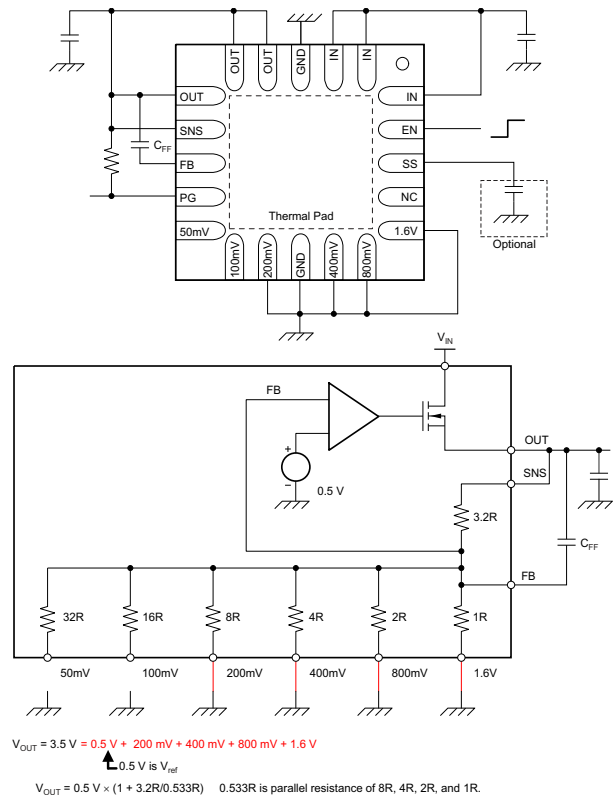

Figure 39. 3.5-V Configuration

See [Table 1](#) for a full list of target output voltages and corresponding pin settings. The voltage setting pins have a binary weight; therefore, the output voltage can be programmed to any value from 0.9 V to 3.5 V in 50-mV steps.

[Figure 12](#) and [Figure 13](#) shows this output voltage programming performance.

NOTE

Any output voltage setting that is not listed in [Table 1](#) is not covered in the Electrical Characteristics. For output voltages greater than 3.5 V, use a traditional adjustable configuration (see the [TRADITIONAL ADJUSTABLE CONFIGURATION](#) section).

Table 1. User Configurable Output Voltage Setting

V _{OUT(TARGET)} (V)	50mV	100mV	200mV	400mV	800mV	1.6V	V _{OUT(TARGET)} (V)	50mV	100mV	200mV	400mV	800mV	1.6V
0.90	open	open	open	GND	open	open	2.25	GND	GND	open	open	open	GND
0.95	GND	open	open	GND	open	open	2.30	open	open	GND	open	open	GND
1.00	open	GND	open	GND	open	open	2.35	GND	open	GND	open	open	GND
1.05	GND	GND	open	GND	open	open	2.40	open	GND	GND	open	open	GND
1.10	open	open	GND	GND	open	open	2.45	GND	GND	GND	open	open	GND
1.15	GND	open	GND	GND	open	open	2.50	open	open	open	GND	open	GND
1.20	open	GND	GND	GND	open	open	2.55	GND	open	open	GND	open	GND
1.25	GND	GND	GND	GND	open	open	2.60	open	GND	open	GND	open	GND
1.30	open	open	open	open	GND	open	2.65	GND	GND	open	GND	open	GND
1.35	GND	open	open	open	GND	open	2.70	open	open	GND	GND	open	GND
1.40	open	GND	open	open	GND	open	2.75	GND	open	GND	GND	open	GND
1.45	GND	GND	open	open	GND	open	2.80	open	GND	GND	GND	open	GND
1.50	open	open	GND	open	GND	open	2.85	GND	GND	GND	GND	open	GND
1.55	GND	open	GND	open	GND	open	2.90	open	open	open	open	GND	GND
1.60	open	GND	GND	open	GND	open	2.95	GND	open	open	open	GND	GND
1.65	GND	GND	GND	open	GND	open	3.00	open	GND	open	open	GND	GND
1.70	open	open	open	GND	GND	open	3.05	GND	GND	open	open	GND	GND
1.75	GND	open	open	GND	GND	open	3.10	open	open	GND	open	GND	GND
1.80	open	GND	open	GND	GND	open	3.15	GND	open	GND	open	GND	GND
1.85	GND	GND	open	GND	GND	open	3.20	open	GND	GND	open	GND	GND
1.90	open	open	GND	GND	GND	open	3.25	GND	GND	GND	open	GND	GND
1.95	GND	open	GND	GND	GND	open	3.30	open	open	open	GND	GND	GND
2.00	open	GND	GND	GND	GND	open	3.35	GND	open	open	GND	GND	GND
2.05	GND	GND	GND	GND	GND	open	3.40	open	GND	open	GND	GND	GND
2.10	open	open	open	open	open	GND	3.45	GND	GND	open	GND	GND	GND
2.15	GND	open	open	open	open	GND	3.50	open	open	GND	GND	GND	GND
2.20	open	GND	open	open	open	GND							

TRADITIONAL ADJUSTABLE CONFIGURATION

For any output voltage target that is not supported in the [USER-CONFIGURABLE OUTPUT VOLTAGE](#) section, a traditional adjustable configuration with external-feedback resistors can be used with the TPS7A7200. [Figure 40](#) shows how to configure the TPS7A7200 as an adjustable regulator with an equation and [Table 2](#) lists recommended pairs of feedback resistor values.

NOTE

The bottom side of feedback resistor R2 in [Figure 40](#) should be in the range of 27 kΩ to 33 kΩ in order to maintain the specified regulation accuracy.

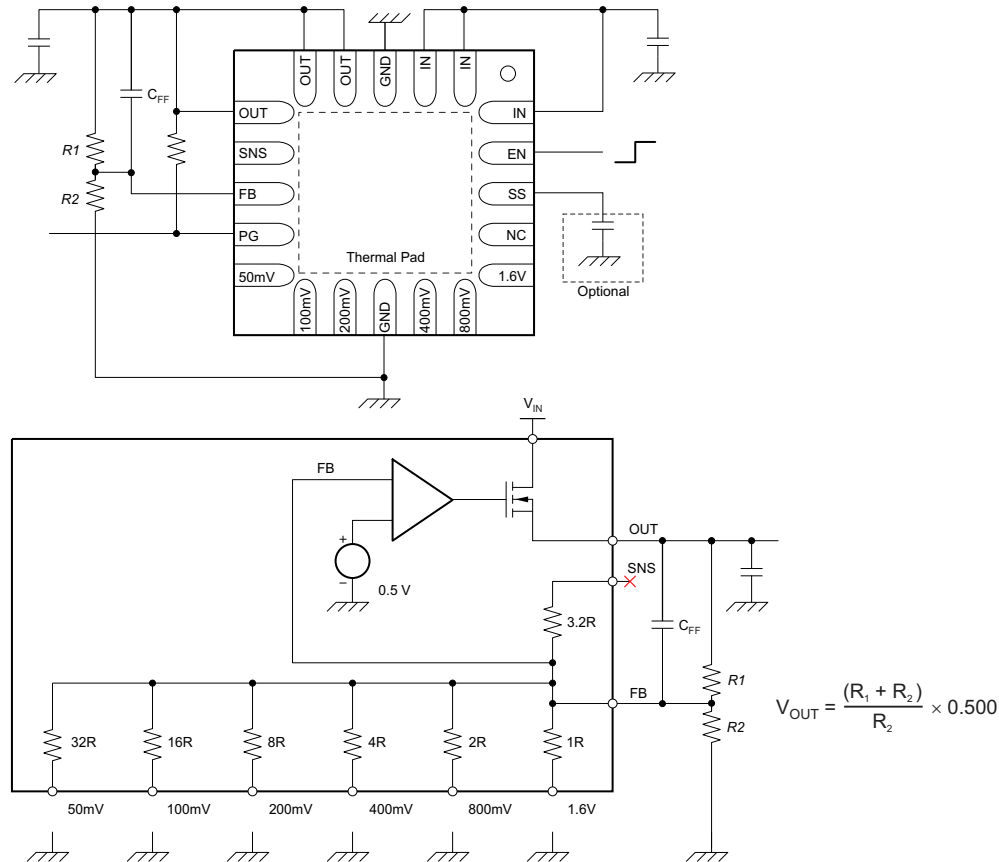

Figure 40. Traditional Adjustable Configuration with External Resistors

Table 2. Recommended Feedback-Resistor Values

V _{OUT(TARGET)} (V)	E96 SERIES		R40 SERIES	
	R1 (kΩ)	R2 (kΩ)	R1 (kΩ)	R2 (kΩ)
1.00	30.1	30.1	30.0	30.0
1.20	39.2	28.0	43.7	31.5
1.50	61.9	30.9	60.0	30.0
1.80	80.6	30.9	80.0	30.7
1.90	86.6	30.9	87.5	31.5
2.50	115	28.7	112	28.0
3.00	147	29.4	150	30.0
3.30	165	29.4	175	31.5
5.00	280	30.9	243	27.2

DROPOUT VOLTAGE

The TPS7A7200 maintains its output voltage regulation with a dropout voltage ($V_{IN} - V_{OUT}$) greater than 0.18 V under the test conditions specified in the Electrical Characteristics. In most power distribution tree (system) designs, the TPS7A7200 can be used with a 0.3-V difference in the common voltage rails (for example, from 3.3 V_{IN} to 3.0 V_{OUT} , from 1.8 V_{IN} to 1.5 V_{OUT} , or from 1.5 V_{IN} to 1.2 V_{IN}).

INPUT CAPACITOR REQUIREMENTS

As a result of its very fast transient response and low-dropout operation support, it is necessary to reduce the line impedance at the input pin of the TPS7A7200. The line impedance depends heavily on various factors, such as wire (PCB trace) resistance, wire inductance, and/or output impedance of the upstream voltage supply (power supply to the TPS7A7200). Therefore, a specific value for the input capacitance cannot be recommended until the previously listed factors are finalized.

In addition, simple usage of large input capacitance is known to form unwanted LC resonance in combination with input wire inductance. For example, a 5-nH inductor and a 10- μ F input capacitor form an LC filter that has a resonance at 712 kHz. This value of 712 kHz is well inside the bandwidth of the TPS7A7200 control loop.

The best guideline is to use a capacitor of up to 1 μ F with well-designed wire connections (PCB layout) to the upstream supply. In case it is difficult to optimize the input line, use a large tantalum capacitor in combination with a good-quality, low-ESR, 1- μ F ceramic capacitor.

OUTPUT CAPACITOR REQUIREMENTS

The TPS7A7200 is designed to be stable with standard ceramic capacitors with capacitance values from 4.7 μ F to 47 μ F. The TPS7A7200 is evaluated using an X5R-type, 10- μ F ceramic capacitor. X5R- and X7R-type capacitors are highly recommended because they have minimal variation in value and ESR over temperature. Maximum ESR should be below 1.0 Ω .

As with any regulator, increasing the size of the output capacitor reduces overshoot and undershoot magnitude, but increases duration of the transient response.

UNDERVOLTAGE LOCK-OUT (UVLO)

The TPS7A7200 uses an undervoltage lock-out circuit to keep the output shut off until the internal circuitry is operating properly. The UVLO circuit has a deglitch feature that typically ignores undershoot of the input voltage upon the event of device start-up. Still, a poor input line impedance may cause a severe input voltage drop when the device powers on. As explained in the [INPUT CAPACITOR REQUIREMENTS](#) section, the input line impedance should be well-designed.

SOFT-START

The TPS7A7200 has a SS pin that provides a soft-start (slow start) function.

By leaving the SS pin open, the TPS7A7200 performs a soft-start by its default setting.

As shown in [Figure 1](#), by connecting a capacitor between the SS pin and the ground, the C_{SS} capacitor forms an RC pair together with the integrated 50-k Ω resistor. The RC pair operates as an RC-delay circuit for the soft-start together with the internal 700- μ s delay circuit.

The relationship between C_{SS} and the soft-start time is shown in [Figure 31](#) through [Figure 33](#).

CURRENT LIMIT

The TPS7A7200 internal current limit circuitry protects the regulator during fault conditions. During a current limit event, the output sources a fixed amount of current that is mostly independent of the output voltage. The current limit function is provided as a fail-safe mechanism and is not intended to be used regularly. Do not design any applications to use this current limit function as a part of expected normal operation. Extended periods of current limit operation degrade device reliability.

ENABLE AND SHUTDOWN THE DEVICE

The EN pin switches the enable and disable (shutdown) states of the TPS7A7200. A logic high input at the EN pin enables the device; a logic low input disables the device. When disabled, the device consumption current is reduced.

POWER GOOD

The TPS7A7200 has a power good function that works with the PG output pin. When the output voltage undershoots the threshold voltage $V_{IT(PG)}$ during normal operation, the PG open-drain output turns from a high-impedance state to a low-impedance state. When the output voltage exceeds the $V_{IT(PG)}$ threshold by an amount greater than the PG hysteresis, $V_{hys(PG)}$, the PG open-drain output turns from a low-impedance state to high-impedance state. By connecting a pull-up resistor (usually between OUT and PG), any downstream device can receive an active-high enable logic signal.

When setting the output voltage to less than 1.8 V and using a pull-up resistor between OUT and PG, depending on the downstream device specifications, the downstream device may not accept the PG output as a valid high-level logic voltage. In such cases, put a pull-up resistor between IN and PG, not between OUT and PG.

Figure 19 shows the open-drain output drive capability. The on-resistance of the open-drain transistor is calculated using Figure 19, and is approximately 200 Ω . Any pull-up resistor greater than 10 k Ω works fine for this purpose.

THERMAL INFORMATION

Thermal Protection

The thermal protection feature disables the output when the junction temperature rises to approximately +160°C, allowing the device to cool. When the junction temperature cools to approximately +140°C, the output circuitry is enabled. Depending on power dissipation, thermal resistance, and ambient temperature, the thermal protection circuit may cycle on and off. This thermal limit protects the device from damage as a result of overheating.

Any tendency to activate the thermal protection circuit indicates excessive power dissipation or an inadequate heatsink. For reliable operation, junction temperature should be limited to +125°C maximum. To estimate the margin of safety in a complete design (including heatsink), increase the ambient temperature until the thermal protection is triggered; use worst-case loads and signal conditions. For good reliability, thermal protection should trigger at least +35°C above the maximum expected ambient condition of your particular application. This configuration produces a worst-case junction temperature of +125°C at the highest expected ambient temperature and worst-case load.

The internal protection circuitry of the TPS7A7200 has been designed to protect against overload conditions. It was not intended to replace proper heatsinking. Continuously running the TPS7A7200 into thermal shutdown degrades device reliability.

Power Dissipation

Knowing the device power dissipation and proper sizing of the thermal plane that is connected to the tab or pad is critical to avoiding thermal shutdown and ensuring reliable operation.

Power dissipation of the device depends on input voltage and load conditions and can be calculated using Equation 1:

$$P_D = (V_{IN} - V_{OUT}) \times I_{OUT} \quad (1)$$

Power dissipation can be minimized and greater efficiency can be achieved by using the lowest possible input voltage necessary to achieve the required output voltage regulation.

On the QFN (RGW or RGT) package, the primary conduction path for heat is through the exposed pad to the PCB. The pad can be connected to ground or be left floating; however, it should be attached to an appropriate amount of copper PCB area to ensure the device does not overheat. The maximum junction-to-ambient thermal resistance depends on the maximum ambient temperature, maximum device junction temperature, and power dissipation of the device and can be calculated using Equation 2:

$$R_{\theta JA} = \left(\frac{+125^{\circ}\text{C} - T_A}{P_D} \right) \quad (2)$$

Knowing the maximum $R_{\theta_{JA}}$, the minimum amount of PCB copper area needed for appropriate heatsinking can be estimated using Figure 41.

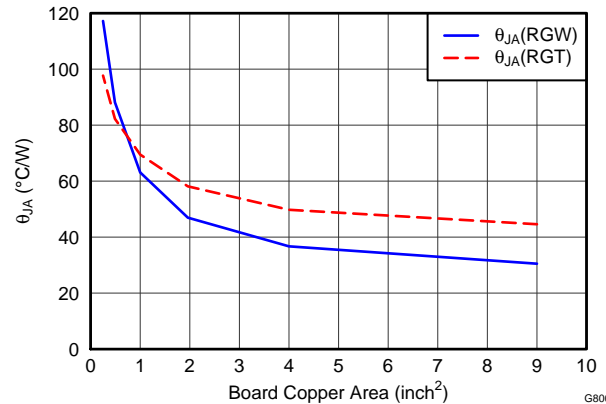

Figure 41. θ_{JA} vs Board Size

shows the variation of θ_{JA} as a function of ground plane copper area in the board. It is intended only as a guideline to demonstrate the effects of heat spreading in the ground plane and should not be used to estimate actual thermal performance in real application environments.

NOTE: When the device is mounted on an application PCB, it is strongly recommended to use Ψ_{JT} and Ψ_{JB} , as explained in the *Estimating Junction Temperature* section.

Estimating Junction Temperature

Using the thermal metrics Ψ_{JT} and Ψ_{JB} , as shown in the *Thermal Information* table, the junction temperature can be estimated with corresponding formulas (given in Equation 3). For backwards compatibility, an older $\theta_{JC, Top}$ parameter is listed as well.

$$\Psi_{JT}: T_J = T_T + \Psi_{JT} \cdot P_D$$

$$\Psi_{JB}: T_J = T_B + \Psi_{JB} \cdot P_D$$

Where:

P_D is the power dissipation shown by Equation 2.

T_T is the temperature at the center-top of the IC package.

T_B is the PCB temperature measured 1mm away from the IC package *on the PCB surface* (see Figure 42). (3)

NOTE: Both T_T and T_B can be measured on actual application boards using a thermo-gun (an infrared thermometer).

For more information about measuring T_T and T_B , see Application Report SBVA025, *Using New Thermal Metrics*, available for download at www.ti.com.

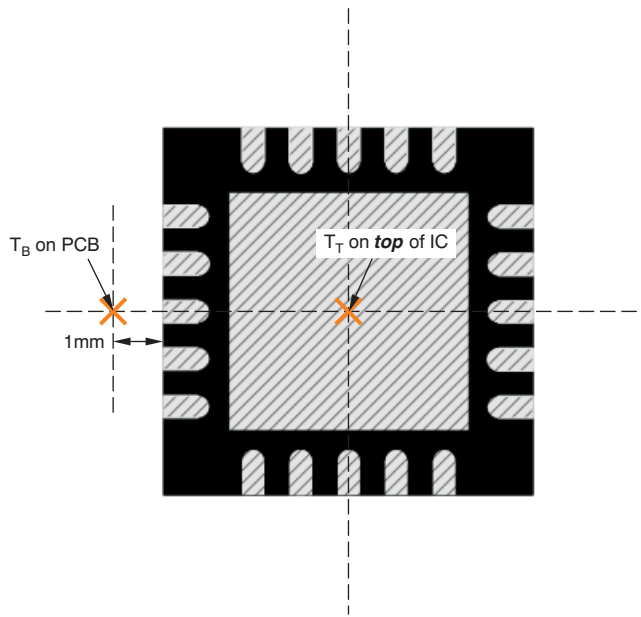

(a) Example RGW (QFN) Package Measurement

Figure 42. Measuring Points for T_T and T_B

By looking at Figure 43, the new thermal metrics (Ψ_{JT} and Ψ_{JB}) have very little dependency on board size. That is, using Ψ_{JT} or Ψ_{JB} with Equation 3 is a good way to estimate T_J by simply measuring T_T or T_B, regardless of the application board size.

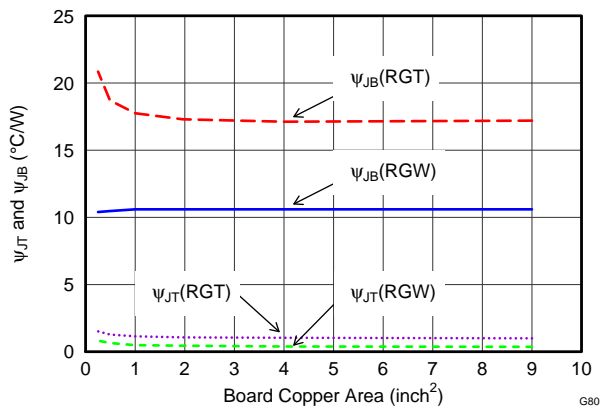

Figure 43. Ψ_{JT} and Ψ_{JB} vs Board Size

For a more detailed discussion of why TI does not recommend using $\theta_{JC(top)}$ to determine thermal characteristics, refer to Application Report SBVA025, *Using New Thermal Metrics*, available for download at www.ti.com. For further information, refer to Application Report SPRA953, *IC Package Thermal Metrics*, also available on the TI website.

PACKAGING INFORMATION

Orderable Device	Status (1)	Package Type	Package Drawing	Pins	Package Qty	Eco Plan (2)	Lead finish/ Ball material (6)	MSL Peak Temp (3)	Op Temp (°C)	Device Marking (4/5)	Samples
TPS7A7200QRGWREP	ACTIVE	VQFN	RGW	20	3000	RoHS & Green	NIPDAU	Level-2-260C-1 YEAR	-40 to 125	SJK	Samples
V62/13612-01XE	ACTIVE	VQFN	RGW	20	3000	RoHS & Green	NIPDAU	Level-2-260C-1 YEAR	-40 to 125	SJK	Samples

(1) The marketing status values are defined as follows:

ACTIVE: Product device recommended for new designs.

LIFEBUY: TI has announced that the device will be discontinued, and a lifetime-buy period is in effect.

NRND: Not recommended for new designs. Device is in production to support existing customers, but TI does not recommend using this part in a new design.

PREVIEW: Device has been announced but is not in production. Samples may or may not be available.

OBSOLETE: TI has discontinued the production of the device.

(2) **RoHS:** TI defines "RoHS" to mean semiconductor products that are compliant with the current EU RoHS requirements for all 10 RoHS substances, including the requirement that RoHS substance do not exceed 0.1% by weight in homogeneous materials. Where designed to be soldered at high temperatures, "RoHS" products are suitable for use in specified lead-free processes. TI may reference these types of products as "Pb-Free".

RoHS Exempt: TI defines "RoHS Exempt" to mean products that contain lead but are compliant with EU RoHS pursuant to a specific EU RoHS exemption.

Green: TI defines "Green" to mean the content of Chlorine (Cl) and Bromine (Br) based flame retardants meet JS709B low halogen requirements of <=1000ppm threshold. Antimony trioxide based flame retardants must also meet the <=1000ppm threshold requirement.

(3) MSL, Peak Temp. - The Moisture Sensitivity Level rating according to the JEDEC industry standard classifications, and peak solder temperature.

(4) There may be additional marking, which relates to the logo, the lot trace code information, or the environmental category on the device.

(5) Multiple Device Markings will be inside parentheses. Only one Device Marking contained in parentheses and separated by a "~" will appear on a device. If a line is indented then it is a continuation of the previous line and the two combined represent the entire Device Marking for that device.

(6) Lead finish/Ball material - Orderable Devices may have multiple material finish options. Finish options are separated by a vertical ruled line. Lead finish/Ball material values may wrap to two lines if the finish value exceeds the maximum column width.

Important Information and Disclaimer:The information provided on this page represents TI's knowledge and belief as of the date that it is provided. TI bases its knowledge and belief on information provided by third parties, and makes no representation or warranty as to the accuracy of such information. Efforts are underway to better integrate information from third parties. TI has taken and continues to take reasonable steps to provide representative and accurate information but may not have conducted destructive testing or chemical analysis on incoming materials and chemicals. TI and TI suppliers consider certain information to be proprietary, and thus CAS numbers and other limited information may not be available for release.

In no event shall TI's liability arising out of such information exceed the total purchase price of the TI part(s) at issue in this document sold by TI to Customer on an annual basis.

OTHER QUALIFIED VERSIONS OF TPS7A7200-EP :

- Catalog: [TPS7A7200](#)

NOTE: Qualified Version Definitions:

- Catalog - TI's standard catalog product

TAPE AND REEL INFORMATION

QUADRANT ASSIGNMENTS FOR PIN 1 ORIENTATION IN TAPE

*All dimensions are nominal

Device	Package Type	Package Drawing	Pins	SPQ	Reel Diameter (mm)	Reel Width W1 (mm)	A0 (mm)	B0 (mm)	K0 (mm)	P1 (mm)	W (mm)	Pin1 Quadrant
TPS7A7200QRGWREP	VQFN	RGW	20	3000	330.0	12.4	5.3	5.3	1.1	8.0	12.0	Q2

TAPE AND REEL BOX DIMENSIONS

*All dimensions are nominal

Device	Package Type	Package Drawing	Pins	SPQ	Length (mm)	Width (mm)	Height (mm)
TPS7A7200QRGWREP	VQFN	RGW	20	3000	346.0	346.0	33.0

GENERIC PACKAGE VIEW

RGW 20

VQFN - 1 mm max height

5 x 5, 0.65 mm pitch

PLASTIC QUAD FLATPACK - NO LEAD

This image is a representation of the package family, actual package may vary.
Refer to the product data sheet for package details.

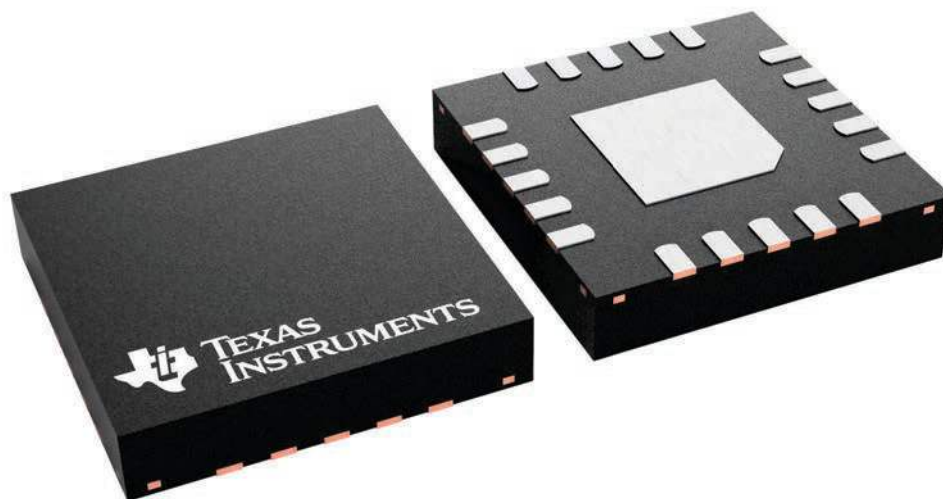

4227157/A

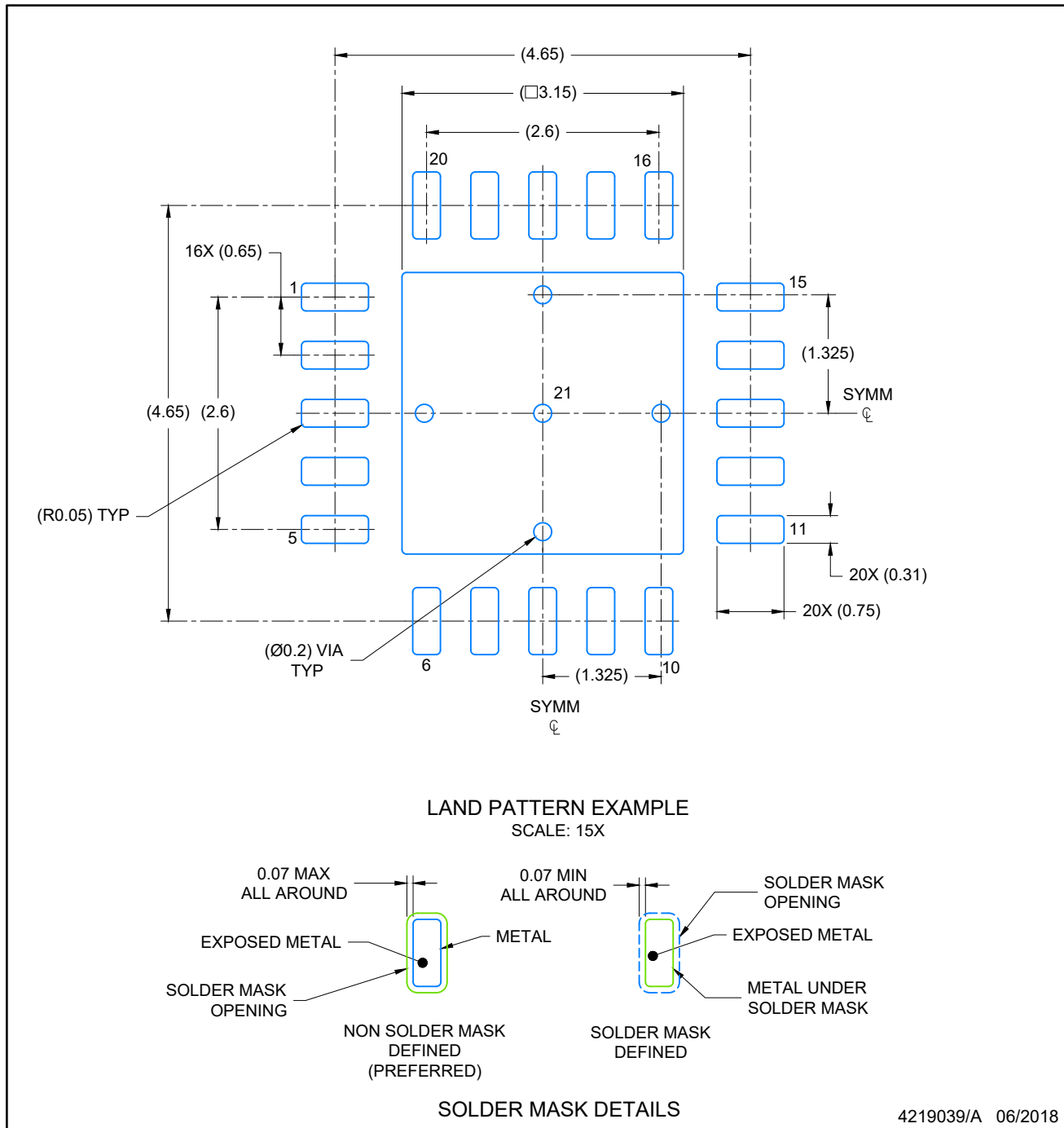

NOTES: (continued)

4. This package is designed to be soldered to a thermal pad on the board. For more information, see Texas Instruments literature number SLUA271 (www.ti.com/lit/sluea271).
5. Vias are optional depending on application, refer to device data sheet. If any vias are implemented, refer to their locations shown on this view. It is recommended that vias under paste be filled, plugged or tented.

EXAMPLE STENCIL DESIGN

VQFN - 1 mm max height

RGW0020A

PLASTIC QUAD FLATPACK-NO LEAD

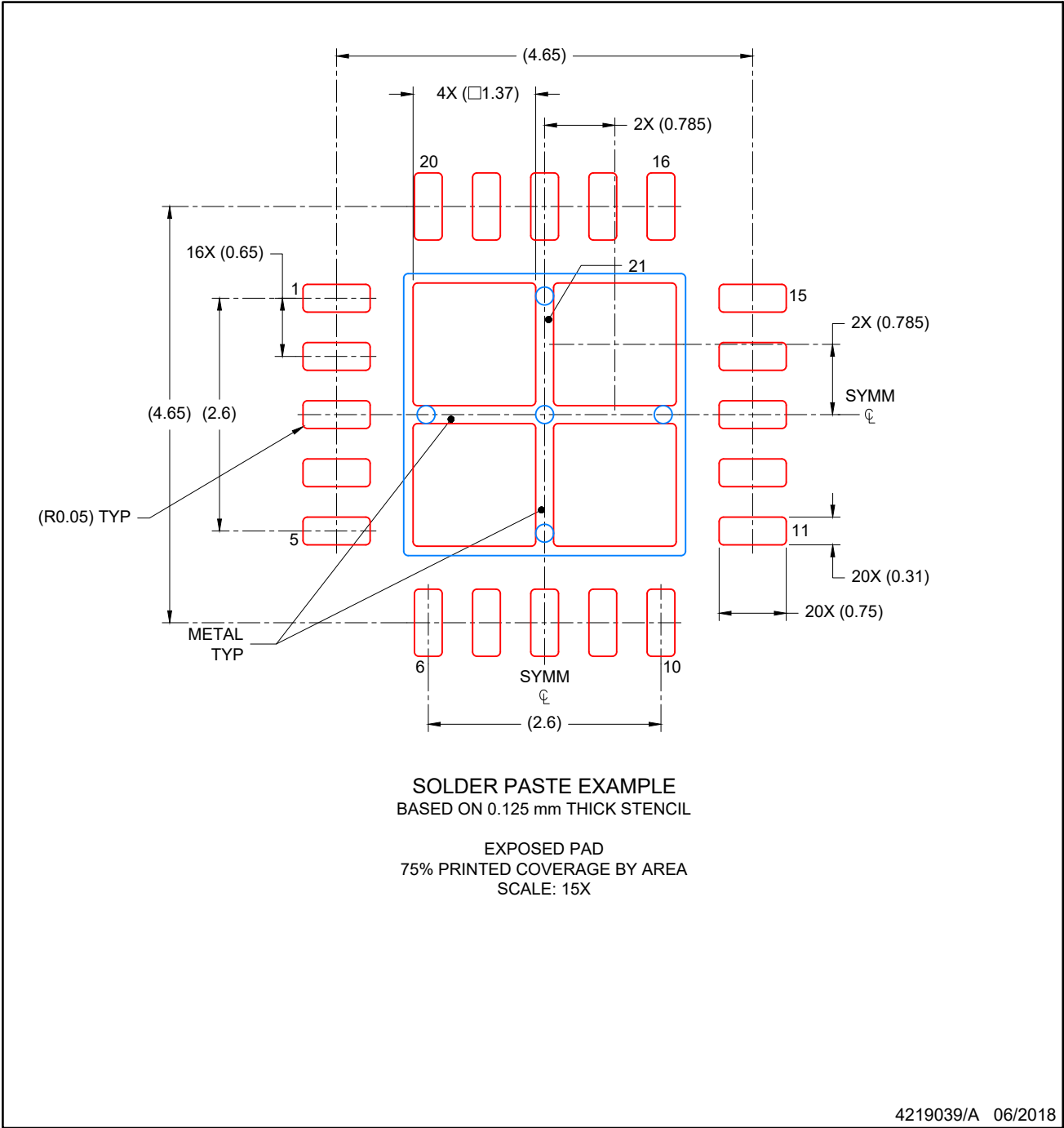

NOTES: (continued)

- 6. Laser cutting apertures with trapezoidal walls and rounded corners may offer better paste release. IPC-7525 may have alternate design recommendations.

IMPORTANT NOTICE AND DISCLAIMER

TI PROVIDES TECHNICAL AND RELIABILITY DATA (INCLUDING DATA SHEETS), DESIGN RESOURCES (INCLUDING REFERENCE DESIGNS), APPLICATION OR OTHER DESIGN ADVICE, WEB TOOLS, SAFETY INFORMATION, AND OTHER RESOURCES "AS IS" AND WITH ALL FAULTS, AND DISCLAIMS ALL WARRANTIES, EXPRESS AND IMPLIED, INCLUDING WITHOUT LIMITATION ANY IMPLIED WARRANTIES OF MERCHANTABILITY, FITNESS FOR A PARTICULAR PURPOSE OR NON-INFRINGEMENT OF THIRD PARTY INTELLECTUAL PROPERTY RIGHTS.

These resources are intended for skilled developers designing with TI products. You are solely responsible for (1) selecting the appropriate TI products for your application, (2) designing, validating and testing your application, and (3) ensuring your application meets applicable standards, and any other safety, security, regulatory or other requirements.

These resources are subject to change without notice. TI grants you permission to use these resources only for development of an application that uses the TI products described in the resource. Other reproduction and display of these resources is prohibited. No license is granted to any other TI intellectual property right or to any third party intellectual property right. TI disclaims responsibility for, and you will fully indemnify TI and its representatives against, any claims, damages, costs, losses, and liabilities arising out of your use of these resources.

TI's products are provided subject to [TI's Terms of Sale](#) or other applicable terms available either on [ti.com](https://www.ti.com) or provided in conjunction with such TI products. TI's provision of these resources does not expand or otherwise alter TI's applicable warranties or warranty disclaimers for TI products.

TI objects to and rejects any additional or different terms you may have proposed.

Mailing Address: Texas Instruments, Post Office Box 655303, Dallas, Texas 75265
Copyright © 2023, Texas Instruments Incorporated