

Signature 3.5 mm AV COMPRESSIVE CONNECTOR, CHAMFERED

“The product may not perform according to the product specification if precautions have not been taken in the application to provide mechanical stability of the connector in relation to its mating parts”.

1 SCOPE.

1.1 Content.

This specification covers performance, test and quality requirements for a Tyco Electronics* 3.5 mm compressive Audio Video connector. The connector is designed to be used in 3.5 mm diam. audio connections for mobile telephone systems.

1.2 Qualification.

When tests are performed on subject product, procedures specified in this specification shall be used. All inspections shall be performed using applicable inspection plan and product drawing.

2 APPLICABLE DOCUMENTS.

The following documents form a part of this specification to the extend specified here. Unless otherwise specified, latest edition of the document applies. In the event of conflict between the requirements in this specification and the product drawing, the product drawing shall take precedence. In the event of conflict between requirements of this specification and referenced documents, this specification shall take precedence.

2.1 Tyco Electronics Documents.

501-19165 Test report of "3.5 mm AV compressive connector, chamfered"

2.2 Tyco Electronics Drawings.

C-1551896 Customer drawing of "3.5 mm AV compressive connector, chamfered"
C-2173014 Customer drawing of "3.5 mm AV compressive connector, chamfered"

2.3 Other Documents.

JEITA EIAJ RC-5325A 4 Pole miniature concentric plugs and jacks
IEC 60512 Basic testing procedures and measuring methods for electromechanical components for electronic equipment.
IEC 60068 Basic environmental testing procedures.
JIS C 6560 Concentric plugs and jacks

M.Gosselink

DATE: 14-Oct-11

APVD:

DATE

EC EHO0-0000-00

3 REQUIREMENTS.

3.1 Design and Construction:

Products shall be of design, construction and physical dimensions as specified on the applicable product drawing.

3.2 Material and Finish:

- A. Contact material: - Cu-alloy.
 - Plating Mating side: - Post-plated with nickel and selective gold.
 - Plating compressive tabs: - Post-plated with nickel and selective gold.
- B. Housing material: - PA

3.3 Ratings:

- A. Voltage: 30 V max.
- B. Current: 2,0 A max./contact
 - Operating temperature: -30°C to 85°C
 - Storage temperature:-40°C to 85°C
 - Storage Humidity Range 15.....70 % RH
- C. Durability: 6000 cycles

3.4 Main Functional Requirement

3.4.1 Jack side requirements

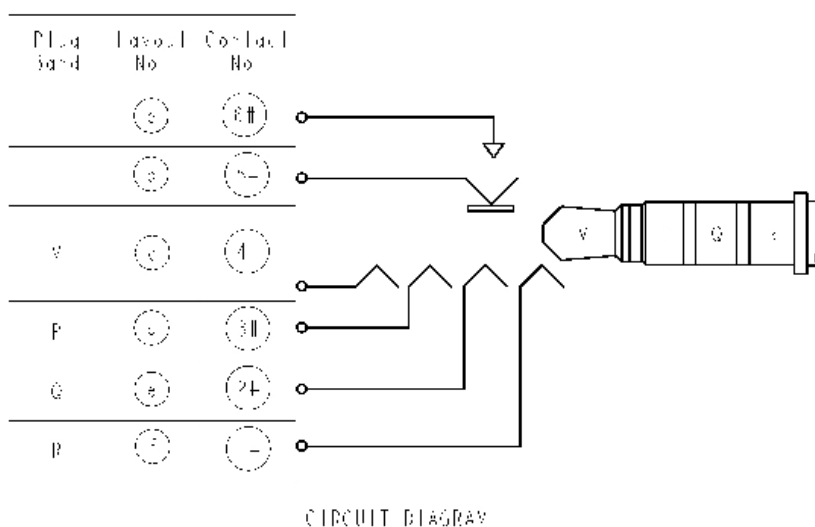

Figure 1. Connector side circuit diagram

Table 1: Signal's of AV Interface			
Contact nr	Signal Name	Direction	Description
1	HS GND	-	Ground contact
2	HS MIC	Input	Multiplexed microphone and control data
3	HS EAR R	Output	Audio Output
4	HS EAR L	Output	Audio Output
5	SWITCH	-	Terminal internal connection, isolated from plug
6	PLUGDET	-	Terminal internal connection, Plug detection

3.4.2 Plug side requirements

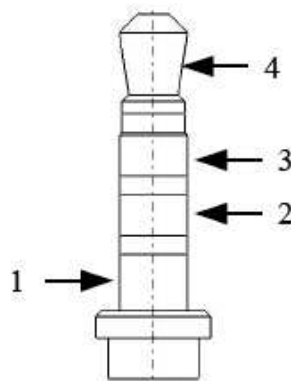

Figure 2: Connector plug

side contacts

3.5 PERFORMANCE AND TEST DESCRIPTION

The product is designed to meet electrical, mechanical and environmental performance specified in this paragraph as tested per test sequence specified in par. 3.6.

Unless otherwise specified, all tests are performed at ambient environmental conditions per IEC specification 60068-1 clause 5.3. and are performed with connectors in mated conditions.

The following must be specified:

1. Testing Method (Standard Number, ex IEC 512-2 test 2a)
2. Number of Testing Samples (5 samples Minimum for each test)
3. Calibration Method

VISUAL			
Para	Description	Performance / Requirements or severity	Procedures
3.5.1	Visual examination	Meets requirements of product drawing and applicable instructions on customer drawing, and application specification.	Visual, dimensional and functional per applicable inspection plan. In acc. With IEC 60512-1-1 Magnification 10x

ELECTRICAL			
Para	Description	Performance / Requirements or severity	Procedures
3.5.2	Contact Resistance (initial)	Ground Contact 20mΩ Max. Other contacts: 60 mΩ Max. Mate Connector with Dry circuit (20mV, 100mA Max.)	IEC 60512-2-1 Measure with gold plated plug according spec: JEITA EIAJ RC-5325A
3.5.3	Insulation Resistance	1000 MΩ Min. Unmated Connector with 500 VDC between adjacent contact for 1 minute	IEC 60512-3-1
3.5.4	Dielectric Strength	No voltage breakdown Unmated Connector with 400 VAC between adjacent contact for 1 minute	IEC 60512-5-2
3.5.5	Temperature rise	Measured at maximum rated current with series all contacts Max. temperature rise 30°C	IEC 60512-5-1

MECHANICAL			
Para	Description	Performance / Requirements or severity	Procedures
3.5.6	Mating-/ unmating Force	Initial mating force max. 25N Initial unmating force min. 5N, max 20N. Align connectors in X direction. Speed 10 mm/min	This requirement has to be fulfilled with all actual plugs and gauges inside tolerance area of JIS C6560
3.5.7	Durability(lifecycle)	No effects that could impair normal operation. Mating forces max 20N after durability test Unmating forces min 5N after 6000 durability test cycles. Contact resistance Ground Contact 60 mΩ Max. Other contacts 100 mΩ Max.	Mate contact 4 – 10 times / min including pause between mate / unmate. Measure insertion- and extraction force with metal test gauge see figure 4, according JIS C 6560 Durability cycles performed with 4 position AV plug according JIS C 6560 JEITA EIAJ RC-5325A
3.5.8	Vibration (random)*	Discontinuity max 1 us all contacts in series.	IEC60068-2-64

		Contact resistance, Ground Contact 60 mΩ Max. Other contacts 100 mΩ Max.frequency: 10 – 100 Hz; 3 m2/s3 (0.0132 g2/Hz); 100 – 500 Hz; -3dB/Oct. for: 3 x 60 min (X- Y- and Z-axis) in minimum deflection position No effects that could impair normal operation.	
3.5.9	Shock*	Discontinuity max 1 us all contacts in series, Contact resistance, Ground Contact 60 mΩ Max. Other contacts 100 mΩ Max. Pulse shape half sine, peak acceleration 50 G, pulse 11 ms, 3 shocks in both directions in XYZ axis (18 shocks) No effects that could impair normal operation	IEC60068-2-27 Ea
3.5.10	Bump*	Discontinuity max 1 us all contacts in series, Contact resistance Ground Contact 60 mΩ Max. Other contacts 100 mΩ Max. No effects that could impair normal operation Peak acceleration 25 G, pulse 6 ms, 1000 shocks in both directions in XYZ axis (6 000 shocks)	IEC 60068-2-29
3.5.11	Bending strength for jack side	Requirement 50 N	See figure 3. Note 1: The A/V jack is assembled into reference mechanics Measurement gage for Jack is made according JEITA EIAJ RC-5325 A; gage material stainless steel.
3.5.12	Axial strength	150 N	See figure 3. Connector is mounted in the test casing according figure 5
3.5.13	Contact force at normal working position (compressed type)	0.8 – 1.3 N/terminal at fully mated condition (initial).	

ENVIRONMENTAL			
Para	Description	Performance/ Requirements or severity	Procedures
3.5.14	Cold	No effects that could impair normal operation Ground Contact 60 mΩ max, other contacts 100 mΩ Max. At=-40°C for 96hours, recovery 2hours at ambient atmosphere	IEC 60068-2-1Ab
3.5.15	Dry heat	No mechanical damage. Ground Contact 60 mΩ Max. Other contacts 100 mΩ Max.. At +85°C for 96hours; recovery 2hours at ambient atmosphere	IEC 60068-2-2Bb
3.5.16	Thermal Shock	No effects that could impair normal operation 25 cycle of Ta=-40°C for 0.5h, then change to 25°C Max. 5 min; then Tb=+85°C for 0.5hours; then cool to ambient. Ground Contact 60 mΩ Max. Other contacts 100 mΩ Max.	IEC 60068-2-14 Test Na Recovery: 2h at ambient atmosphere.
3.5.17	Damp Heat Cyclic	No effects that could impair normal operation Resistance Ground Contact 60 mΩ Max. Other contacts 100 mΩ Max. 18 cycles of 24h in operational mode, mated condition. RH 90-100%, 25->55°C in 3h, then maintain for 9h, then 55->25°C in 3h, maintain 9h	IEC 60068-2-30 Recovery at 25°C RH75% for 2h. Measure resistance without opening the mating.
3.5.18	Condensing humidity cyclic	No effects that could impair normal operation. Resistance Ground Contact 60 mΩ Max. Other contacts 100 mΩ Max. 96h in operational mode, mated condition, RH90%, 60°C for 30min-> then 60 to 10°C in 25min, then maintain for 30min, then 10 to 60°C in 20min. This cycle profile is continued for 4 days.	Recovery at 25°C RH 75% for 2h. Measure resistance without opening the mating.
3.5.19	Salt spray	No effects that could impair normal operation	IEC60068-2-11 Ka

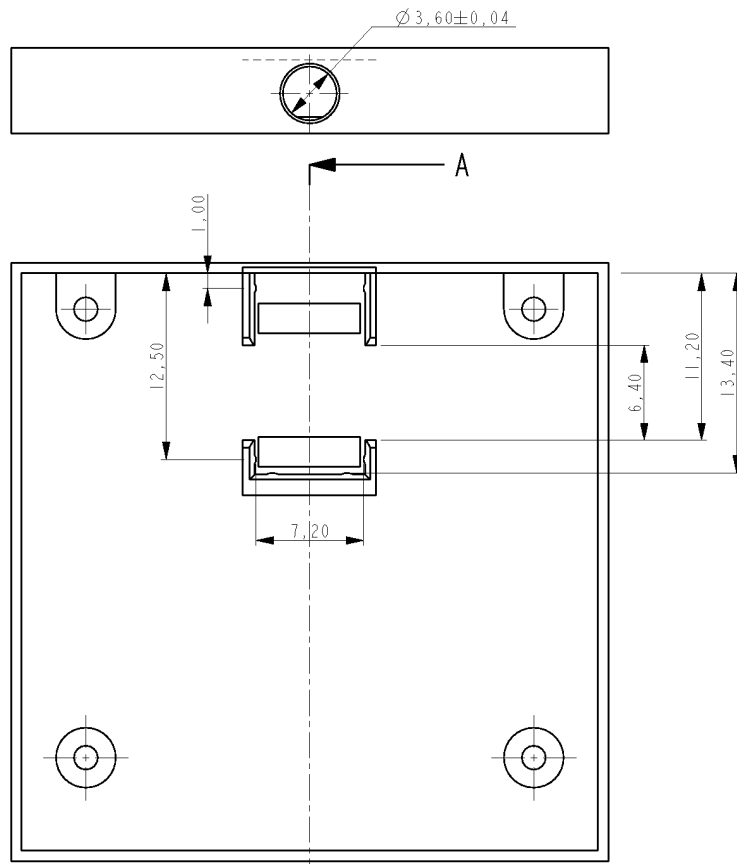

Figure 5 Test Cover for bending strength test

3.6 Product Qualification and Requalification Test Sequence.

Test group 1

- 1 Visual Examination
- 2 Contact Resistance
- 3 Insulation Resistance
- 4 Dielectric Strength
- 5 **Cold**
- 6 **Dry Heat**
- 7 Contact Resistance
- 8 Insulation Resistance
- 9 Dielectric Strength
- 10 **Thermal Shock**
- 11 Contact Resistance
- 12 Insulation Resistance
- 13 Dielectric Strength
- 14 **Damp Heat Cyclic**
- 15 Contact Resistance
- 16 Insulation Resistance
- 17 Dielectric Strength
- 18 **Condensing Humidity**
- 19 Contact Resistance
- 20 Insulation Resistance
- 21 Dielectric Strength
- 22 Visual Examination

Test group 2

- 1 Visual Examination
- 2 Contact Force
- 3 Contact Resistance
- 4 Mating / Unmating Forces
- 5 **Durability**
- 6 Mating / Unmating Forces
- 7 Contact Resistance
- 8 Visual Examination

Test group 3

- 1 Visual Examination
- 2 Contact Resistance
- 3 **Salt Spray**
- 4 Contact Resistance
- 5 Visual Examination

Test group 4

- 1 Visual Examination
- 2 Contact Resistance
- 3 **Bending strength**
- 4 Contact Resistance
- 5 Visual Examination

Test group 5

- 1 Visual Examination
- 2 Contact Resistance
- 3 **Axial Strength**
- 4 Contact Resistance
- 5 Visual Examination

Test group 6

- 1 Visual Examination
- 2 Contact Force
- 3 Contact Resistance
- 4 **Temperature rise**
- 5 Contact Resistance
- 6 Visual Examination

4 QUALITY ASSURANCE PROVISIONS.

4.1 Qualification testing.

A. Sample selection

Samples shall be prepared in accordance with applicable instructions and shall be selected at random from current production.

B. Test sequence

Qualification inspection shall be verified by testing samples as specified in par. 3.6.

4.2 Requalification testing.

If changes significantly affecting form, fit or function are made to product or manufacturing process, product assurance shall coordinate requalification testing, consisting of all or part of original testing sequence as determined by product, quality and reliability engineering.

4.3 Acceptance.

Acceptance is based upon verification that product meets requirements of par. 3.5. Failures attributed to equipment, test set-up, applied customer components or operator deficiencies shall not disqualify the product. When product failure occurs, corrective action shall be taken and samples resubmitted for requalification. Testing to confirm corrective action is required before resubmitted.

4.4 Quality conformance inspection.

Applicable Tyco Electronics quality inspection plan will specify sampling acceptable quality level to be used.

Dimensional and functional requirements shall be in accordance with applicable product drawing and this specification.